

Service Manual

ViewSonic N3250w-G

Model No. VS10769-1G

32" LCD TV Display

(N3250w-G_SM Rev. 1a Jan. 2006)

ViewSonic® 381 Brea Canyon Road, Walnut, California 91789 USA - (800) 888-8583

Copyright

Copyright © 2006 by ViewSonic Corporation. All rights reserved. No part of this publication may be reproduced, transmitted, transcribed, stored in a retrieval system, or translated into any language or computer language, in any form or by any means, electronic, mechanical, magnetic, optical, chemical, manual or otherwise, without the prior written permission of ViewSonic Corporation.

Disclaimer

ViewSonic makes no representations or warranties, either expressed or implied, with respect to the contents hereof and specifically disclaims any warranty of merchantability or fitness for any particular purpose. Further, ViewSonic reserves the right to revise this publication and to make changes from time to time in the contents hereof without obligation of ViewSonic to notify any person of such revision or changes.

Trademarks

Optiquest is a registered trademark of ViewSonic Corporation.
ViewSonic is a registered trademark of ViewSonic Corporation.
All other trademarks used within this document are the property of their respective owners.

Revision History

Revision	SM Editing Date	Documents Number		Description of Changes	Editor
		DCN Number	ECR Number		
1a	01/03/06	5805S		Initial Release	A. Lu

TABLE OF CONTENTS

1. Precautions and Safety Notices	1
2. Service Tool & Equipment Required	4
3. Specification	4
4. Adjustment Procedure	8
5. Packing For Shipping And Disassembly Procedure	27
6. Troubleshooting Flow Chart	35
7. Exploded View	39
8. Recommended Spare Parts List	41
9. Block Diagram	48
10. Schematic Diagrams	49
11. Working Theorem	60
12. Wiring Diagram	62
13. PCB Layout Diagrams	63

1. Precautions and Safety Notices

1.1. SAFETY PRECAUTIONS

This LCD TV is manufactured and tested on a ground principle that a user's safety comes first. However, improper use or installation may cause damage to the LCD TV as well as to the user. Carefully go over the following WARNINGS before installing and keep this guide handy.

WARNINGS:

- ◆ This LCD TV should be operated only at the correct power sources indicated on the label on the rear end of the LCD TV. If you're unsure of the power supply in your residence, consult your local dealer or power company.
- ◆ Use only the special power adapter that comes with this LCD TV for power input.
- ◆ Do not try to repair the LCD TV yourself as it contains no user-serviceable parts. This LCDTV should only be repaired by a qualified technician.
- ◆ Do not remove the LCD TV cabinet. There is high-voltage parts inside that may cause electric shock to human bodies, even when the power cord is unplugged.
- ◆ Stop using the LCD TV if the cabinet is damaged. Have it checked by a service technician.
- ◆ Put your LCD TV only in a clean, dry environment. If it gets wet, unplug the power cable immediately and consult your service technician.
- ◆ Always unplug the LCD TV before cleaning it. Clean the cabinet with a clean, dry cloth. Apply non-ammonia based cleaner onto the cloth, not directly onto the glass screen.
- ◆ Keep the LCD TV away from magnetic objects, motors, TV sets, and transformer.
- ◆ Do not place heavy objects on the LCD TV or power cord.

1.2. PRODUCT SAFETY NOTICE

Many electrical and mechanical parts in this chassis have special safety visual inspections and the protection afforded by them cannot necessarily be obtained by using replacement components rated for higher voltages, wattage, etc. Before replacing any of these components read the parts list in this manual carefully. The use of substitute replacement parts which do not have the same safety characteristics as specified in the parts list may create shock, fire, or other hazards.

1.3. SERVICE NOTES

1. When replacing parts or circuit boards, clamp the lead wires around terminals before soldering.
2. When replacing a high wattage resistor (more than 1W of metal oxide film resistor) in circuit board, keep the resistor about 5mm away from circuit board.
3. Keep wires away from high voltage, high temperature components and sharp edges.
4. Keep wires in their original position so as to reduce interference.
5. Usage of this product please refer to also user's manual.





LCD TV Handling Precautions

1. Handling Precautions

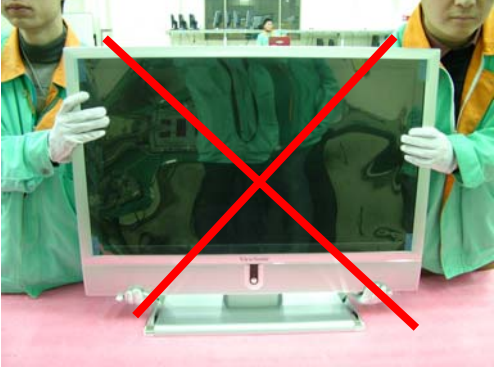
- (1) Since front polarizer is easily damaged, pay attention not to scratch it.
- (2) Be sure to turn off power supply when inserting or disconnecting from input connector.
- (3) Wipe off water drop immediately. Long contact with water may cause discoloration or spots.
- (4) When the panel surface is soiled, wipe it with absorbent cotton or other soft cloth.
- (5) Since the panel is made of glass, it may break or crack if dropped or bumped on hard surface.
- (6) Since CMOS LSI is used in this module, take care of static electricity and insure human earth when handling.
- (7) Do not open nor modify the Module Assembly.
- (8) Do not press the reflector sheet at the back of the module to any directions.
- (9) In case if a Module has to be put back into the packing container slot after once it was taken out from the container, do not press the center of the CCFL Reflector edge. Instead, press at the far ends of the CFL Reflector edge softly. Otherwise the TFT Module may be damaged.
- (10) At the insertion or removal of the Signal Interface Connector, be sure not to rotate nor tilt the Interface Connector of the TFT Module.
- (11) After installation of the TFT Module into an enclosure (LCD TV housing, for example), do not twist nor bend the TFT Module even momentary. At designing the enclosure, it should be taken into consideration that no bending/twisting forces are applied to the TFT Module from outside. Otherwise the TFT Module may be damaged.
- (12) Cold cathode fluorescent lamp in LCD contains a small amount of mercury. Please follow local ordinances or regulations for disposal.
- (13) Small amount of materials having no flammability grade is used in the LCD module. The LCD module should be supplied by power complied with requirements of Limited Power Source (IEC60950 or UL1950), or be applied exemption.
- (14) The LCD module is designed so that the CFL in it is supplied by Limited Current Circuit (IEC60950 or UL1950). Do not connect the CFL in Hazardous Voltage Circuit.

2. Handling and Placing Methods

Correct Methods:	Incorrect Methods:
Only touch the metal frame of the LCD panel or the front cover of the LCD TV. Do not touch the surface of the polarizer.	Surface of the LCD panel is pressed by fingers and that may cause "Mura"
	

<p>Take out the LCD TV with cushions</p>	<p>Taking out the LCD TV by grasping the LCD panel. That may cause "Mura"</p>
	
<p>Place the LCD TV on a clean and soft foam pad.</p>	<p>Placing the LCD TV on foreign objects. That could scratch the surface of the panel or cause "Mura"</p>
	

2. Service Tool & Equipment Required

1. SIGNAL GEN.
2. MULTIMETER
3. OSCILLOSCOPE
4. SCREW DRIVER
5. IRON
6. ABSORBER
7. SOLDER
8. DUMMY LOAD (5A/200W)
9. DVD PLAYER

3. SPECIFICATIONS

3.1. PRODUCT SPECIFICATIONS

LCD Panel	32" TFT
Power Management (OFF MODE)	< 5W
Displayable Resolution	VESA 1280×1024 max.
Pixel Dimension	0.51075(H)×0.5107 (W)mm
LCD Display Color	16.7M Color Max. (8bit/color)
Viewing Angle	CR ≥10 Horizontal: -85°+85° Vertical: -85°+85°
Contrast Ratio	800 : 1 (typical)
Brightness	500 cd/m ² (typical)
Response Time	Tr: 8 ms , Tf: 8ms (typical)
Active Display Area	679.68mm×392.26mm
RF Tuner	Input level: 0 ~ +15 dB mV Rang: NTSC 55.25 to 801.25 MHz, 2-69 channels for Off-Air and 2-125 Channeis for CATV
Power	Voltage: 100~240 V Consumption: 200 Watts (Max.)
Speaker	10W×2
Compliance	FCC,UL
Temperature	Operating : 0°C~ +40°C Storage : -20°C~+60°C

3.2. FACTORY SUPPORTING MODES

ITEM	1	2	3	4
TIMING	640×480 60HZ	640×480 75HZ	800×600 60HZ	800×600 75HZ
Pixel Rate	25.175MHZ	31.500MHZ	40.000MHZ	49.500MHZ
H TOTAL	31.778us	26.667us	26.400us	21.333us
H DISPLAY	25.422us	20.317us	20.000us	16.162us
H B-Porch	1.907us	3.810us	2.200us	3.232us
H Width	3.813us	2.032us	3.200us	1.616us
H Border	0.318us	0.000us	0.000us	0.000us
V TOTAL	16.683ms	13.334ms	16.579ms	13.333ms
V DISPLAY	15.253ms	12.800ms	15.840ms	12.800ms
V B-Porch	1.049ms	0.427ms	0.607ms	0.448ms
Vs Width	0.064ms	0.080ms	0.106ms	0.064ms
V Border	0.254ms	0.000ms	0.000ms	0.000ms
H/V Sync	-/-	-/-	+/+	+/+
Interlace	No.	No.	No.	No.

ITEM	5	6	7	8
TIMING	1024×768 60HZ	1024×768 75HZ	1280×720 60HZ	1280×768 60HZ
Pixel Rate	65.000MHZ	78.750MHZ	74.250MHZ	65.000MHZ
H TOTAL	20.677us	16.660us	22.222us	20.677us
H DISPLAY	15.754us	13.003us	17.239us	15.754us
H B-Porch	2.462us	2.235us	2.936us	2.462us
H Width	2.092us	1.219us	1.007us	2.092us
H Border	0.000us	0.000us	0.000us	0.000us
V TOTAL	16.666ms	13.328ms	16.667ms	16.666ms
V DISPLAY	15.880ms	12.795ms	16.000ms	15.880ms
V B-Porch	0.600ms	0.466ms	0.444ms	0.600ms
Vs Width	0.124ms	0.050ms	0.111ms	0.124ms
V Border	0.000ms	0.000ms	0.000ms	0.000ms
H/V Sync	-/-	+/+	-/-	-/-
Interlace	No.	No.	No.	No.

ITEM	9	10	11	12
TIMING	1360×768 60HZ	1280×1024 60HZ		
Pixel Rate	85.5MHZ	108MHZ		
H TOTAL	20.959us	15.630us		
H DISPLAY	15.906us	11.852us		
H B-Porch	2.994us	2.296us		
H Width	1.310us	1.037us		
H Border	0.000us	0.000us		
V TOTAL	16.662ms	16.661ms		
V DISPLAY	16.097ms	16.005ms		
V B-Porch	0.377ms	0.594ms		
Vs Width	0.126ms	0.047ms		
V Border	0.00ms	0.00ms		
H/V Sync	+/+	+/+		
Interlace	No.	No.		

3.3. D-SUB & DVI CONNECTOR

Connector pin assignments for VGA cable

The signal cable connector shall be a molded-over, shield twisted pair cable. The cable shall be 1.8 meters long. The pin assignments shall be listed as below:

PIN	D-SUB Connector
1	Red Video
2	Green Video
3	Blue Video
4	NC
5	GND
6	GND
7	GND
8	GND
9	+5V for DDC
10	GND
11	NC
12	SDA
13	H-sync
14	V-sync
15	SCL

Connector pin assignments for DVI cable

DVI: 25 pins DVI connector is designed to match with DVI digital signal cable, the pin assignment is as the following:

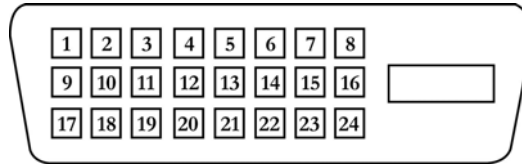

* 25 pins DVI female

Pin	Signal Assignment	Pin	Signal Assignment	Pin	Signal Assignment
1	TMDS RX2-	9	TMDS RX1-	17	TMDS RX0-
2	TMDS RX2+	10	TMDS RX1+	18	TMDS RX0+
3	TMDS Ground	11	TMDS Ground	19	TMDS Ground
4	Floating	12	Floating	20	Floating
5	Floating	13	Floating	21	Floating
6	DDC Clock	14	+5V Power	22	TMDS Ground
7	DDC Data	15	Ground	23	TMDS Clock+
8	Floating	16	Hot Plug Detect	24	TMDS Clock-

4. Adjustment Procedure

4.1. ADJUSTMENT CONDITIONS AND PRECAUTIONS

1. Approximately 30 minutes should be allowed for warm up before proceeding.
2. Adjustments should be undertaken only on those necessary elements since most of them have been carefully preset at the factory.
3. ESD protection is needed before adjustment.

4.2. MAIN ADJUSTMENTS

NO.	FUNCTION	DESIGNATION
1.	EEPROM Initial	Function Key
2.	White Balance	Function Key

4.3. ALIGNMENT PROCEDURES

Adjustment Conditions and Precautions:

- (A). Power supply voltage:
AC 110/120V±10% 60 Hz±5%, AC 220/240V±10% 50 Hz±5%.
- (B). Warm up time:
The display must be power ON for at least 30 minutes at full white pattern before starting alignments.
This is especially critical in color temperature and white balance adjustments.
- (C). Signals: reference the front detail specifications and timing table.
Video : reference the front detail specifications.

1. EEPROM Initial:

- A. Timing : 1024x768@60Hz.
- B. Pattern : Cross hatch.
- C. Switch off the power and press the “▲” and “” key simultaneously, and switch on the power. At this time we can enter into the factory mode.
- D. Select the “EEPROM INIT” item and press “”key to reset the EEPROM.

2. White Balance Adjustment :

- A. Timing : 1024x768@60Hz.
- B. Pattern : 16 gray.
- C. Set CA110 color analyzer at the center of screen and along a perpendicular to the screen at 20cm from the display.
- D. Press menu key select the OSD page on INPUT SELECT and select MAIN:VGA.
- E. Press menu key change the OSD page to adjust page.
- F. Press “▼” key to select the “ WHITE BALANCE” item in the factory mode and press “”key, then the white balance will be auto dadjusted .
- G. Color temperature verification :

Warm /SRGB	x=0.313±0.03	y=0.329±0.03
USER	x=0.283±0.03	y=0.298±0.03
COOL	x=0.271±0.03	y=0.278±0.03

Y≥380 cd/m²

4-4 Adjusting Procedure

1. Function Test

1.1. Product

- 32" LCD TV

1.2. Test Equipment

- PC signal generator: CHROMA 2130,2135,2325,2326 or 2525.
- TV, Video signal generator: SHIBASOKU TG91CC.
- AV, S-Video, HD, and SCART signal generator: DVD.
- Color analyzer: MINOLTA CA110.
- Power meter: CP-310A or CP-320A.

1.3. Test Condition

Before function test and alignment, each LCD TV should be run-in and warmed up for at least 30 minutes with the following conditions:

- (a) In room temperature,
- (b) With full-white screen, and 16 grey scale,
- (c) With cycled display modes.

1.4. Test Display Modes & Pattern

1.4.1 EEPROM INIT

- A. Timing: 1366*768@60Hz
- B. Pattern: 16*12 pane
- C. Press 'POWER', '▲' and 'ENTER' at the same time, then go into the FACTORY MODE.



Fig.1

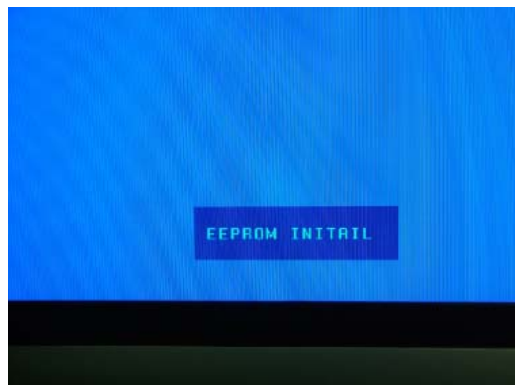

Fig.2

D. Figure 1,press ENTER, and the Fig. 2 come out. The act of EEPROM INITIAL is completed when EEPROM INIT disappeared. And remove OSD to WHITE BALANCE.

1.4.2 COLOR TEMPERATURE ADJUSTING

PC MODE:

- A. Timing: 1280*1024@75Hz.
- B. Pattern: 16 grey scale and full white.
- C. LCD TV should be run-in and warmed up for at least 30 minutes.
- D. Make sure the distance between SENOR of the CA110 and the LCD TV is about 20cm.
- E. Color Temperature adjusting.



Fig. 3



Fig. 4

1. Fig. 3: under the picture of 16 grey scale, select WHITE BALANCE and press ENTER, The color warm will auto adjust, the same as Fig. 4. The act of WHITE BALANCE is completed when WHITE BALANCE disappeared.
2. After adjusting, switch to FULL WHITE and check the value of each color.
 Preset color for N3250W(G)
 USER----9300 x=0.285±0.015 y=0.293±0.015
 Warm SRGB----6500 x=0.313±0.015 y=0.329±0.015
 COOL----12000 x=0.271±0.015 y=0.278±0.015

HD MODE:

- A. Timing: PAL OR NTSC.
 - B. Pattern: Color bar
 1. Figure 3: under the picture of color bar , select WHITE BALANCE and press ENTER, The color warm will auto adjust, the same as Figure 4. The act of WHITE BALANCE is completed when WHITE BALANCE disappeared.
 2. Normal----9300 x=0.285±0.015 y=0.293±0.015
 Warm ----6500 x=0.313±0.015 y=0.329±0.015
 COOL----12000 x=0.271±0.015 y=0.278±0.015
- 1.4.3. Check the position of the picture displayed and phase auto adjusting.
- A. Under TV Mode, check the picture of GREY, if there are some white point flashes or blue point, please adjusts DDR-ADJUST to normal state.
 - B. Depend on the TIMING of TIMING TABLE (Engineer Spec.) to switch MODE in order, stay about 10 seconds each MODE, it can changed and stored automatically each MODE. We can't switch over to the next MODE until AUTO ADJUST disappears.
 - C. Need confirm after adjusting, each MODE really change and store.
- 1.4.4. POWER SAVING TEST:
- A. Timing: 640*480@75Hz.
 - B. Pattern: TEST-TTL/ECL.
 - C. BRIGHTNESS=MAX, CONTRAST=MAX.
 - D. The power that each MODE consumes is shown in Chart 1.

MODE	MAX POWER CONSUMED	POWER LED COLOR
NORMAL	<200W	GREEN
Standby	<5W	ORANGE
OFF	<5W	RED

Chart 1

1.4.5 OSD FUNCTION TEST:

- A. Timing: 640*480 @75Hz.
- B. Pattern: "GENERAL-1".
- C. Make sure that Each FUNCTION have one right action.
- D. After adjusting and confirming no error, we can take delivery of goods until it set as default.

1.4.6 Under PC MODE, input PC AUDIO signal, determines whether the action of AUDIO IN is right. Meets earphone with the EARPHONE, Determined whether the action of AUDIO OUT is normal.

CHANNEL ORDER	FREQUENCY (MHz)	Broadcasting System	SET CONTENT			CHECK CONTENT
			PATTERN	SOUND	P/S(dB)	
P0	45.75	PAL I	Mono Scope	FM Mono (Sweep Tone)	-5	Mechanical electrical unusual sound
P1	55.75	SECAM L	Color Bar	Nicam Stereo*2	-16	image to sound disturbance
P2	160.00	SECAM L	Mono scope	FM Mono*1 (400Hz)	-16	NOISE LIMITED SENSITIVITY
P3	440.25	PAL D/K	Full White 100%	Nicam Stereo*2	-10	sound image brightness effect
P4	471.25	PAL B/G	Dem	Nicam Stereo*2	-10	Stereo Function
P5	567.25	PAL I	Multi-Burst	Nicam Dual	-10	Dual Function
P6	855.25	PALB/G	Color Bar	Nicam Stereo*2	-16	Mechanical electrical unusual sound
P7	863.25	PAL D/K	Mono Scope	FM Mono*1 (400Hz)	-16	NOISE LIMITED SENSITIVITY

Chart 2

- Note: 1. Sound working pattern: Int Osc 400Hz;
 Sound modulation: standard.
 2. Stereo content setting: Left sound track 3KHz; Right sound track 1KHz.

1.4.7.TV RECEIVING TEST:

- P0. Examines sound by ear, whether the sound does have mechanical resonance and the electrical unusual sound, and image to sound disturbance.
- P1. Examines whether the sound does receive the image disturbance, Judgment basis: Whether there is unusual sound, input signal LEVEL<=36dBu,and STEREO SENSITIVITY is normal.
- P2. Adjustment attenuator, If the critical point of the change of the image signal to noise ratio is under LEVEL<=60dBu,regards as normally.
- P3. Examines TV brightness; confirm whether DUAL FUNCTION is normal under DUAL MODE: whether DUAL SENSITIVITY is normal when input signal is under LEVEL<=36dBu.
- P4. Examines whether PAL color demodulation is normal by using DEM image; whether STEREO SENSITIVITY is normal when input signal is under LEVEL<=36dBu.
- P5. Examines whether DUAL FUNCTION is normal under DUAL MODE; whether DUAL SENSITIVITY is normal when input signal is under LEVEL<=36dBu.
- P6. Examines whether the sound does receive the image disturbance, Judgment basis: Whether there is unusual sound, input signal LEVEL<=36dBu,and STEREO SENSITIVITY is normal.
- P7. Adjustment attenuator, If the critical point of the change of the image signal to noise ratio is under LEVEL<=60dBu,regards as normally.

1.4.8.VIDEO RECEIVING TEST:

AV receives supply oscillator: AV/S-Video/HD/SCART1/SCART2/SCART-SV are from DVD to LCD TV; Examines whether has the image and the sound and is normal.

- (1). AV: Video cable (Yellow), Audio cable (Left (White), Right (Red) sound track).
- (2). S-Video: S-Video signal cable (White), Audio cable (Left (White), Right (Red) sound track).
- (3). HD (Ypbpr/YcbCr): brightness signal cable (Green), Component signal cable (Red, Blue), Audio cable (Left (White), Right (Red) sound track).
- (4). SCART1: 21Pin SCART signal cable (Black).
- (5). SCART2: 21Pin SCART signal cable (Black).

1.4.9.VIDEO/AUDIO OUTPUT TEST:

- (1). SCART/AV output: A 32” LCD TV in AV pattern, inputs the CVBS signal; the output meets SCART, SCART connects another 32” LCD TV which is in SCART pattern, Examines two 32” LCD TV whether demonstrates the same image. But their sound doesn’t mutually affect, Must respectively adjust volume to examine sound. AV output test method is in the same way.
- (2). Under any pattern except PC pattern, The Audio output meets active extra speaker, examines whether the extra speaker makes the sound.

1.5 Compatible Mode Table

All timings must be properly PHASED, SIZED, and CENTERED.

Aspect Ratio=Resolution to which the native signal is SCALED and CENTERED

1:1=Centered,1:1 Pixel Correlation, No Scaling. No Filtering, Image must be properly phased.

Full Screen=The Input timing is scaled to full screen, regardless of scaling artifacts.

=>640*480

N/A=Not Applicable to a green timing.

MODE	CVBS	SVHS	YCBCR (scart CVBS)	YPBPR (scart RGB)	RGB (D-Sub)	HDMI (HDCP)	TV
RF(Analog)	NO	NO	NO	NO	NO	NO	YES
576i	YES	YES	YES	YES	NO	YES	NO
576p	NO	NO	NO	YES	NO	YES	NO
HD 720p	NO	NO	NO	YES	NO	YES	NO
HD 1080i	NO	NO	NO	YES	NO	YES	NO
640*480@60Hz	NO	NO	NO	NO	YES	YES	NO
640*480@75Hz	NO	NO	NO	NO	YES	YES	NO
800*600@60Hz	NO	NO	NO	NO	YES	YES	NO
800*600@75Hz	NO	NO	NO	NO	YES	YES	NO
1024*768@60Hz	NO	NO	NO	NO	YES	YES	NO
1024*768@75Hz	NO	NO	NO	NO	YES	YES	NO
1280*720@60Hz	NO	NO	NO	NO	YES	YES	NO
1280*768@60Hz	NO	NO	NO	NO	YES	YES	NO
1360*768@60Hz	NO	NO	NO	NO	YES	YES	NO
1280*1024@60Hz	NO	NO	NO	NO	YES	YES	NO

Chart 3. Mode Compatibility Table---N3250W(G)

MODE	1:1	FS	FAR
576i**	N/A	1366*768	1024*768*
576p**	N/A	1366*768	1024*768*
HD 720p	1250*700	1366*768	N/A
HD 1080i	N/A	1366*768	N/A
640*480@60Hz	N/A	1366*768	1024*768*
640*480@75Hz	N/A	1366*768	1024*768*
800*480@60Hz	800*600	1366*768	1024*768*
800*600@75Hz	800*600	1366*768	1024*768*
1024*768@60Hz	1024*768*	1366*768	N/A
1024*768@75Hz	1024*768*	1366*768	N/A
1280*720@60Hz	1280*720*	1366*768	N/A
1280*768@60Hz	1280*768*	1366*768	N/A
1360*768@60Hz	1360*768*	N/A	N/A
1280*1024@60Hz	N/A	1366*768*	N/A

Chart 4. ASPECT RATIO CONTROLS (YPBPR/RGB/HDCP Only): Viewing Window
(on 1366*768 panel)---N3250W(G)

*=Default Setting,**=These modes also woke on CVBS/SVHS/YCBCR inputs

1.6 All Modes Reset

After final QC step, we have to erase all saved changes again and restore the factory defaults. You should do “All Mode Reset” again.
Power Off LCD TV.
Turn off the LCD TV by pressing “Power” button.

2. Firmware Upgrade Procedure

When you receive the returned LCD TV, please check whether the firmware version is the latest. If not, please do the following procedures to upgrade it to the latest version.

2.1. Equipment Needed

- N3250W(G) LCD TV
- Fixture for Firmware Upgrade
- VGA Cable
- PC (Personal Computer)
- LPT Cable
- Firmware Upgrade Program
- One additional LCD TV for checking the program execution

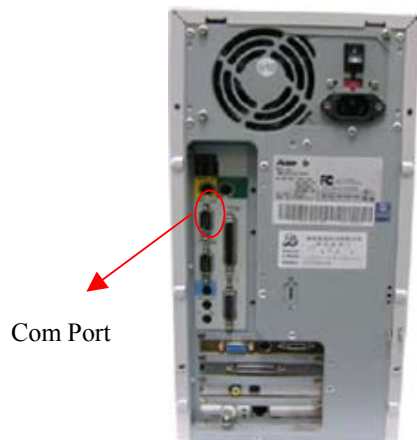

PC



N3250W(G) LCD TV



RS-232 Cable (pin to pin)



VGA Cable

2.2. Setup Procedure

- 2.2.1 Connect P2 of Fixture with printer port of PC by LPT Cable.
- 2.2.2 Connect P1 of Fixture with N3250W(G) LCD TV by VGA Cable.
- 2.2.4 Connect Power Cord to N3250W(G) LCD TV.
- 2.2.5 Connect PC to the additional LCD TV.

2.3. ISP Download program procedure

2.3.1 Hardware Connect status:

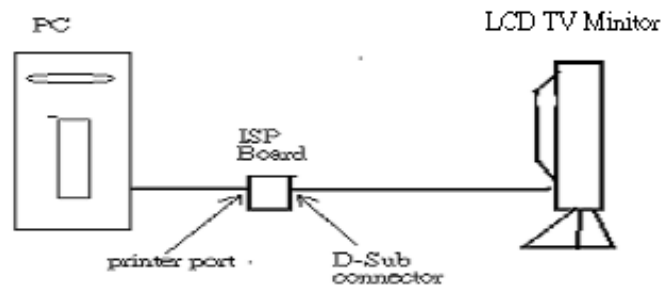

2.3.2 Download ISP program

Step 1: Execute ISP.exe

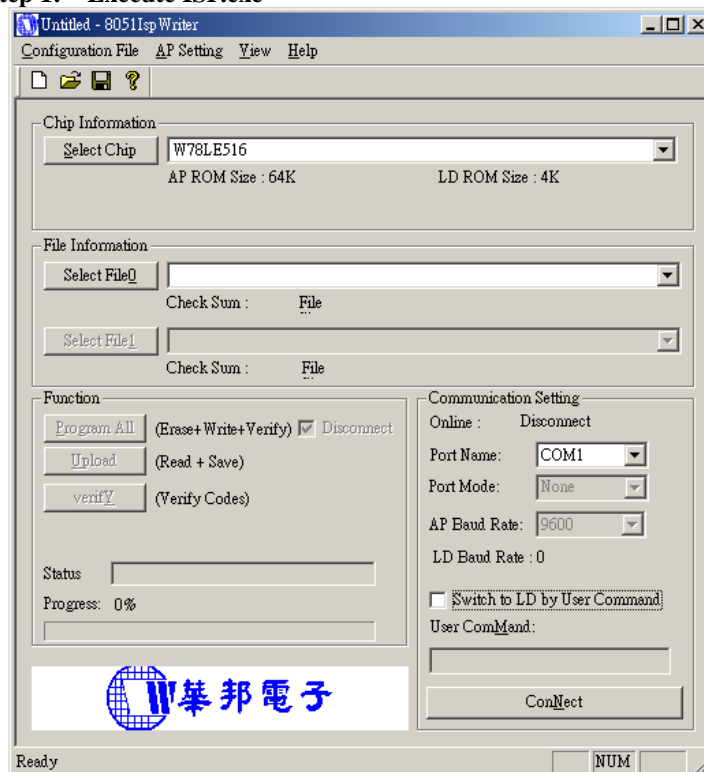

Step 2: Select MCU type

Pressing the Comb box to select the type of the MCU, It need to be selected the N3250W(G) LCD TV for this project., then press the OK Button.

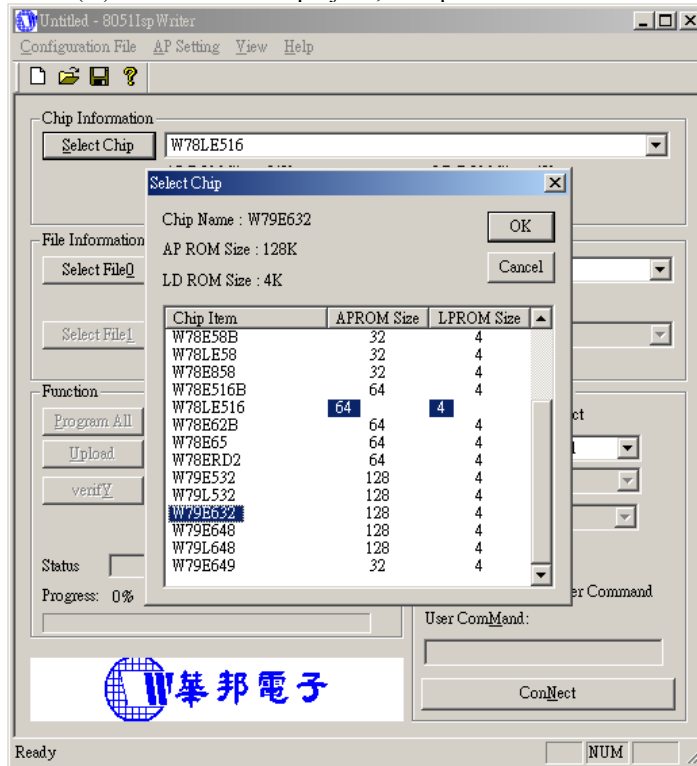

Step 3: Load file

Press the Load MCU File button to select the file (File 0 and File 1) will be downloaded. (*.Hex)

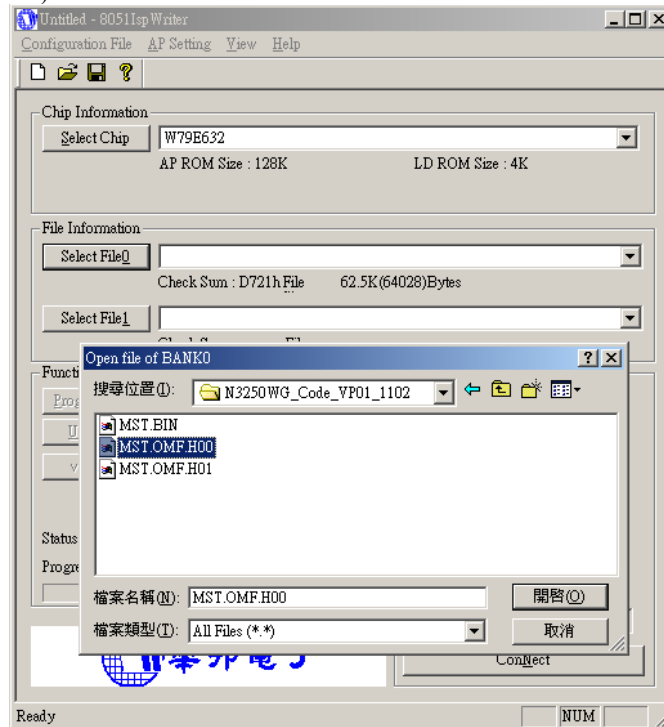

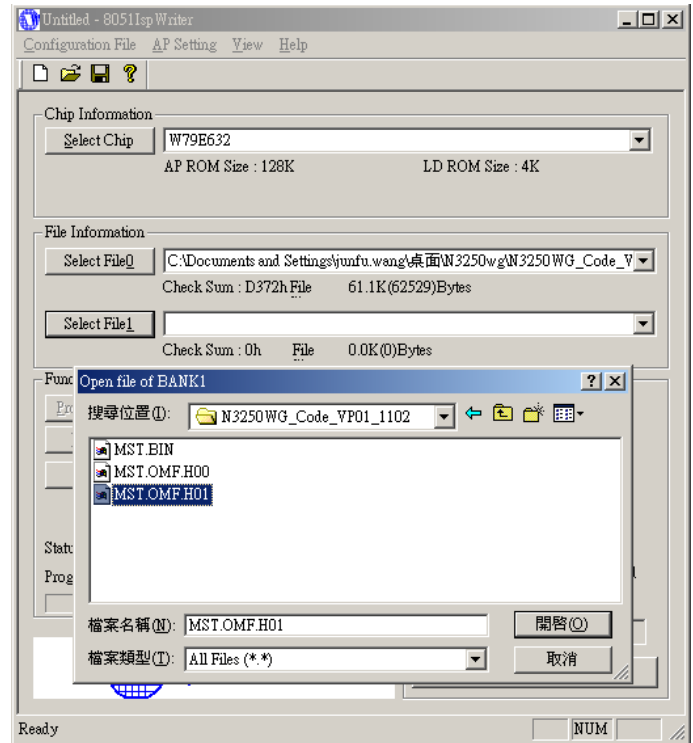
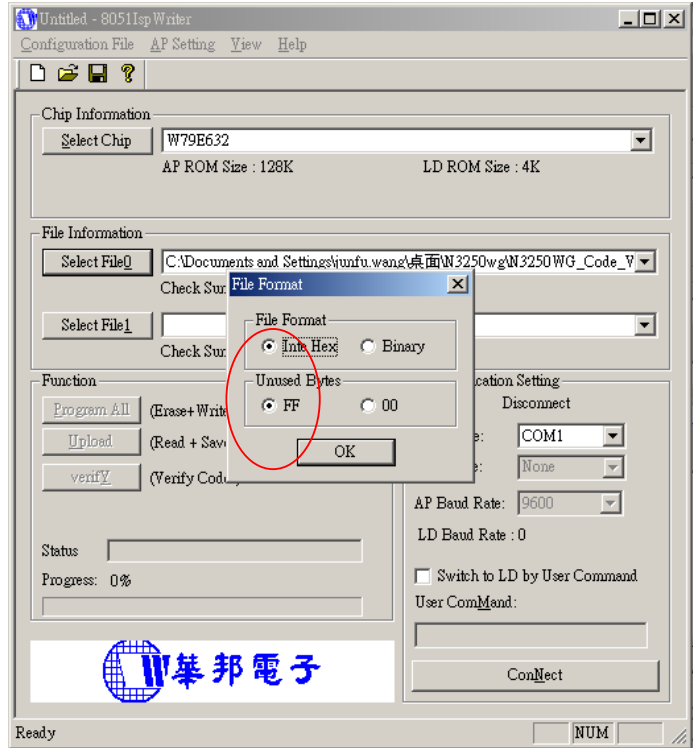

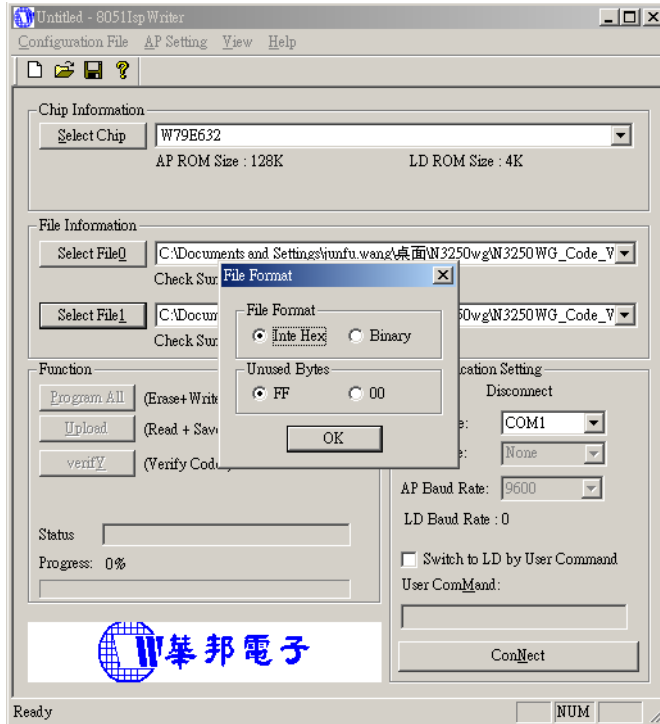

Step 4: Test Communication

Pressing the ConNect button to test whether the communication is well.

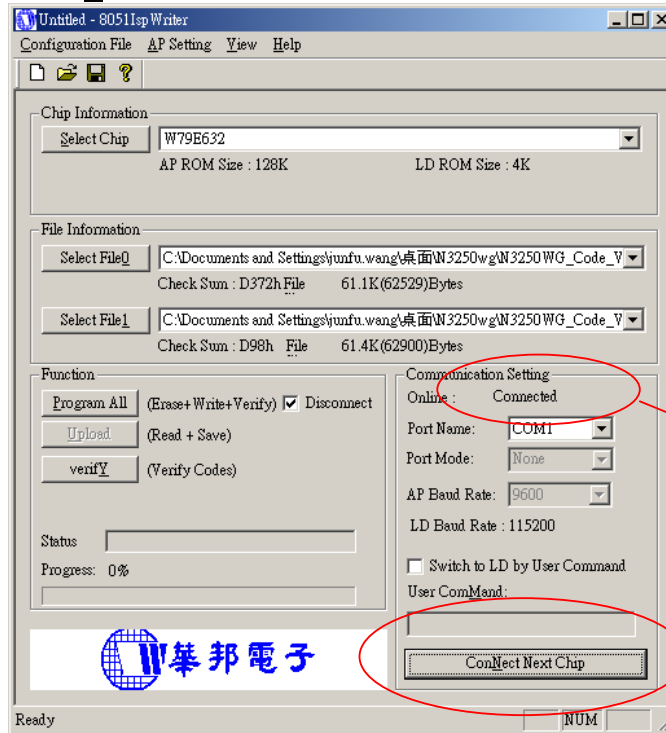

Testing Result

Step 5: Run

Pressing the Program All to start download program. Pressing the 'OK' Button to finish the download program procedure.

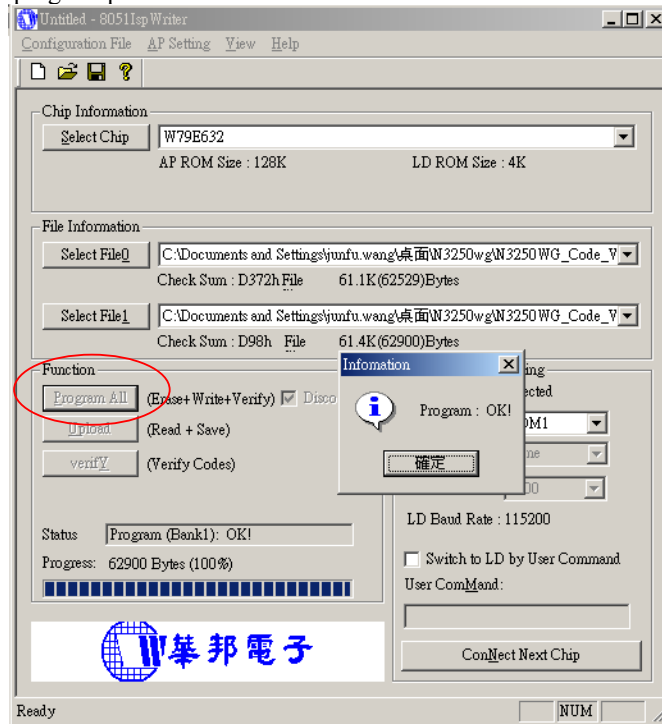

Trouble shooting:

If you find the status like the follow picture. Please check the following item.

- The connecting status between PC and ISP board.
- The connecting status between ISP status and LCD TV.

Turn off the power of LCD TV (AC plug off) and disconnect the D-Sub connector. To connect the D-Sub connector and then turn on the power of LCD TV.(AC plug on)

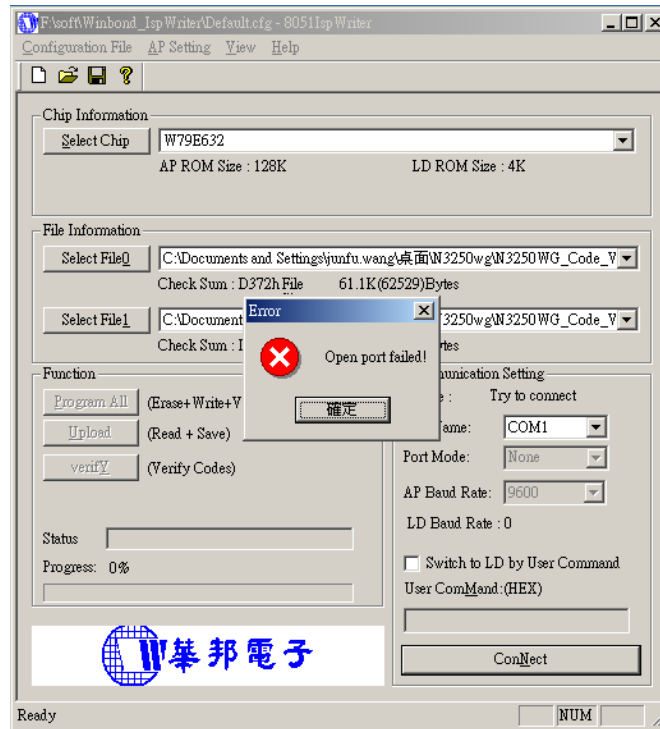

If the test result shows “Connected,” it means the connection is well. If not (failed), it means the connection has problems. Then you need to check the setup procedure or reboot the PC, or simply use another PC to do the firmware upgrade.

3. DDC Key In Procedure

Note:

1. Every time after replacing the main board, you have to do the DDC key in.
2. If you find the DDC does not conform to the LCD TV, you have to do the DDC key in.

3.1. Equipment Needed

- N3250W(G) LCD TV
- DDC Card
- PC
- RS232 cable
- Barcode Reader
- VGA Cable



N3250W(G) LCD TV



DDC Card



PC



RS-232 Cable



VGA Cable



Barcode Reader

3.2. Setup Procedure

3.2.1 Connect VGA Card and DDC Card with RS-232 cable.



3.2.2 Barcode Reader connect with keyboard and PC keyboard port.



3.2.3 Connect RS-232 Cable and N3250W(G) LCD TV with VGA Cable.
(when key in DVI DDC information, use VGA transform to DVI port)
3.2.4 Connect Power Cord to N3250W(G) LCD TV.

3.3. DDC Key In Procedure

3.3.1 Run DDC.exe

3.3.2 Choose model number and conform the Time then Press “ENTER” key.

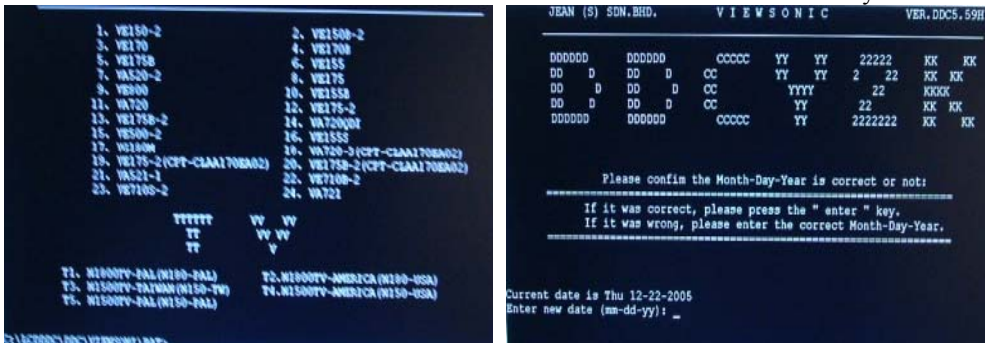

3.3.3 When appear the PIC “choose DDC Card”, Press ALT+2 Enter DDC 2B test interface.



Choose DDC Card

3.3.4 Press F8 to choose corresponding model.DAT (N3250W-G.DAT press “ENTER” key)

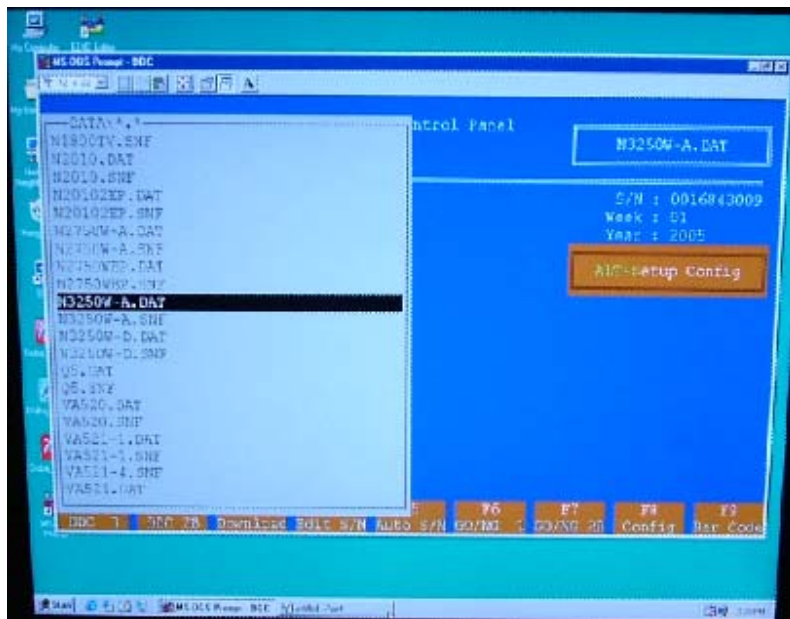

3.3.5 Press F9 enter the download interface

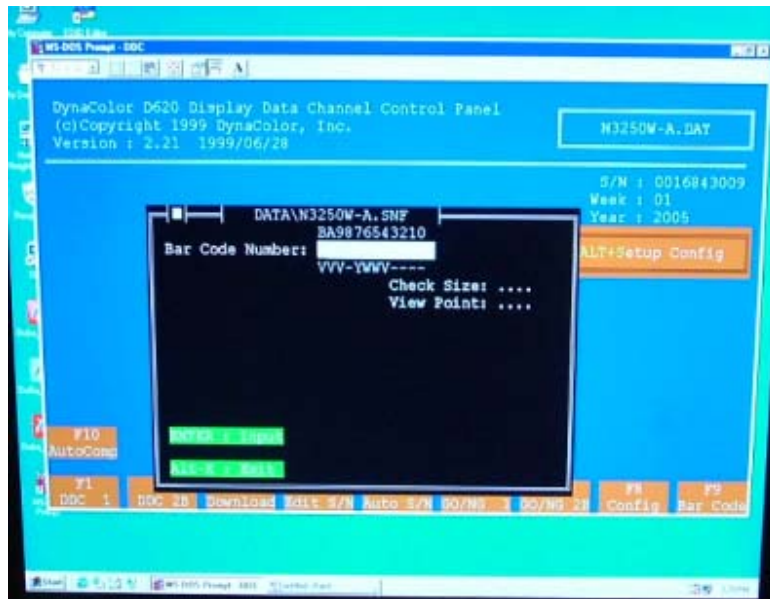

3.3.6 Key in the serial number or use the barcode reader to scan the barcode of the LCD TV, and press “ENTER” key.

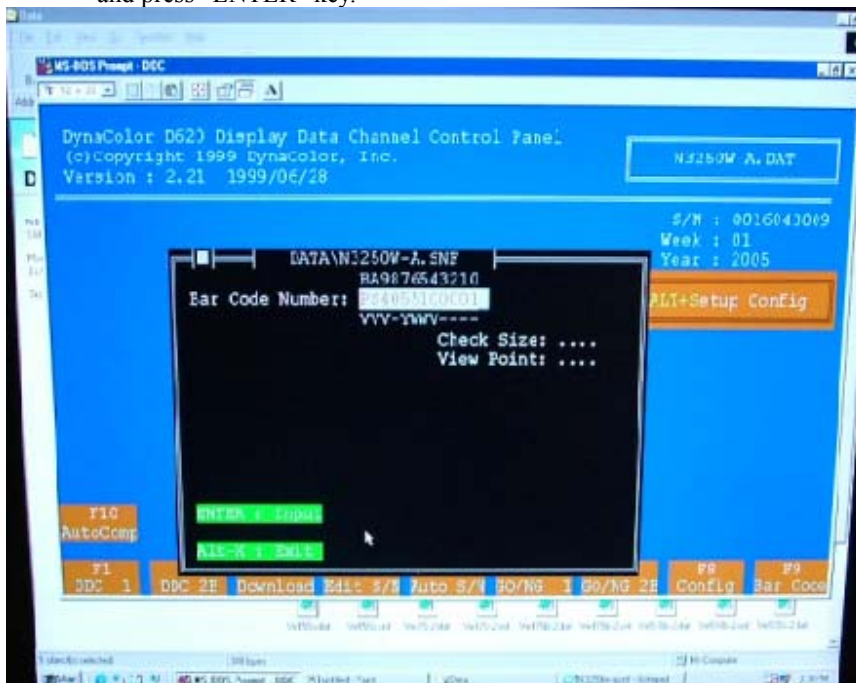

3.3.7 The successful picture is as follows. "Compare EDID:OK! Press any key to continue".

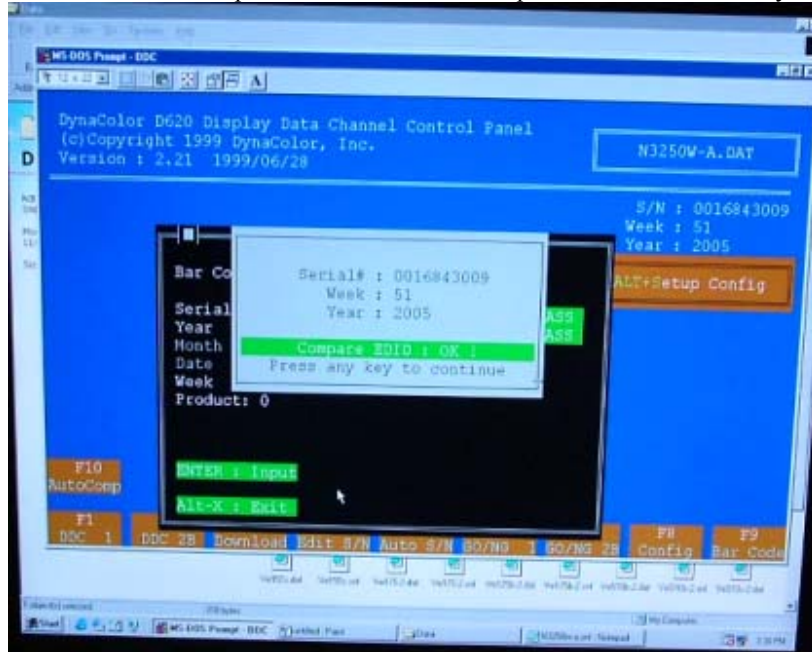

3.4. Check Method

Use ViewSonic EDID Editor

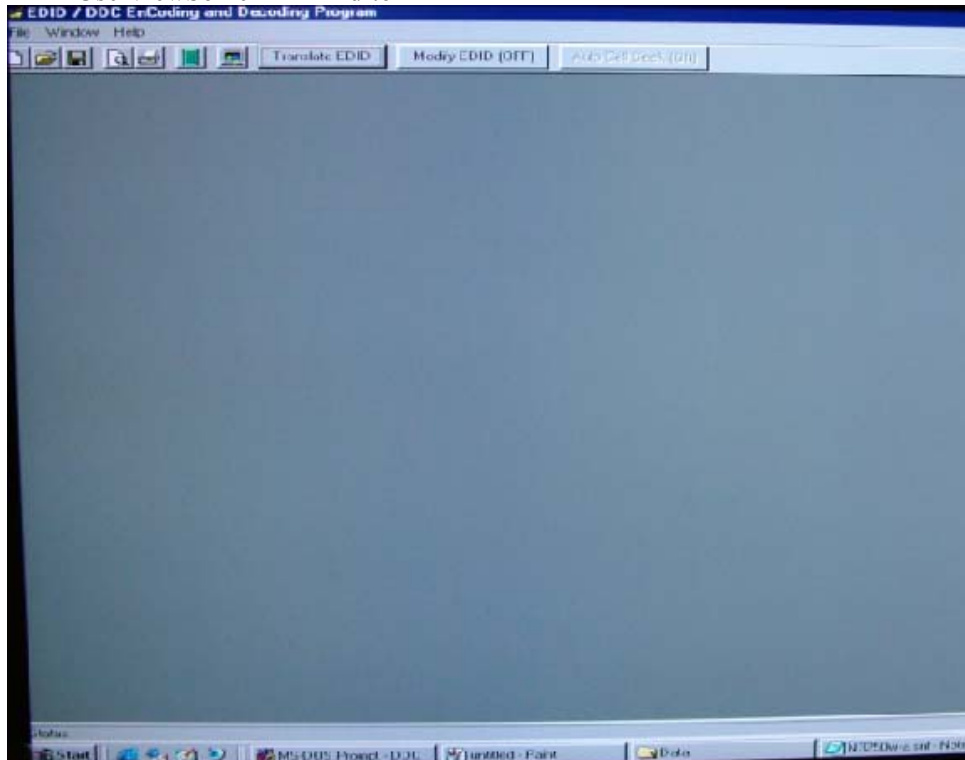

Connect the N3250W(G) LCD TV to PC with VGA Cable. Excute the EDID Editor, then Press Ctrl+F5. If the DDC is correct, you can see the information as follow:

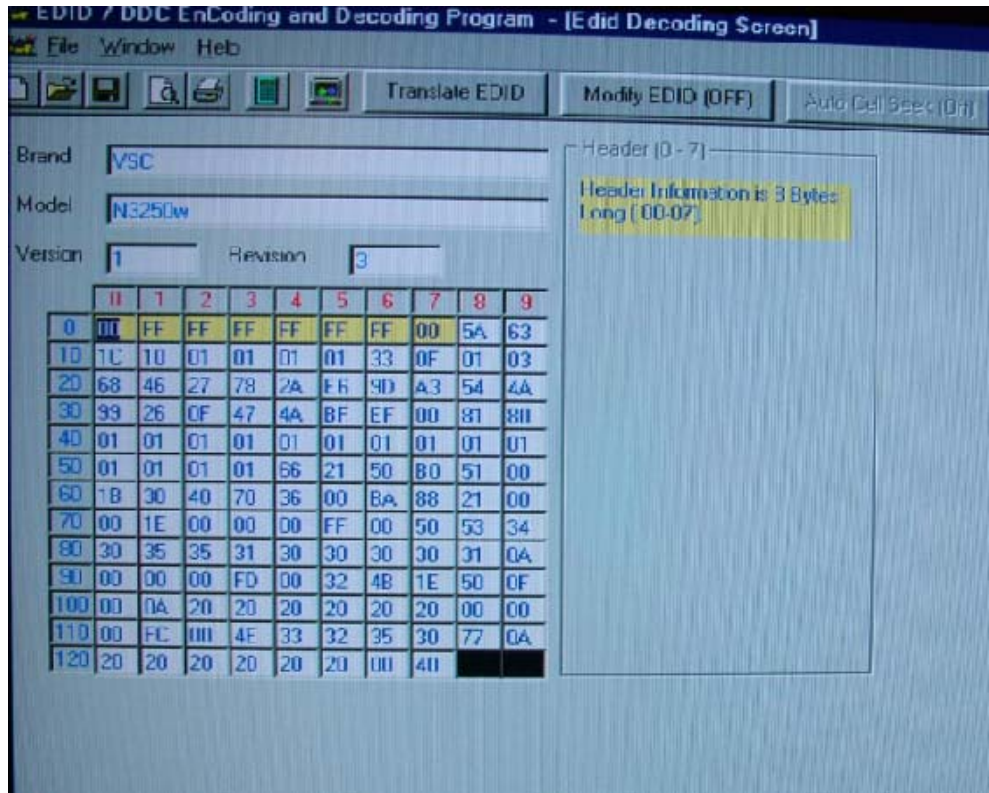

5. Packing For Shipping And Disassembly Procedure

Packing For Shipping

1. Packing Procedure

1.1 Paste protection film to protect the LCD TV. (Figure 1)

1.2 Put the LCD TV in the PE bag and seal the bag. (Figure 2)



Figure 1



Figure 2

1.3 Put the cushions on the LCD TV. (Figure 3)

1.4 Place the LCD TV into the carton and then Put the other cushions on the LCD TV, put all the accessories into the carton. At last, close the carton and seal it with tape. (Figure 4)

1.Power Cord 2.VGA Cable 3.SCART Cable
4.RCA Cable 5.User's Guide 6.Remote contrl
7. GUARANT CARD 8.BATTERY



Figure 3

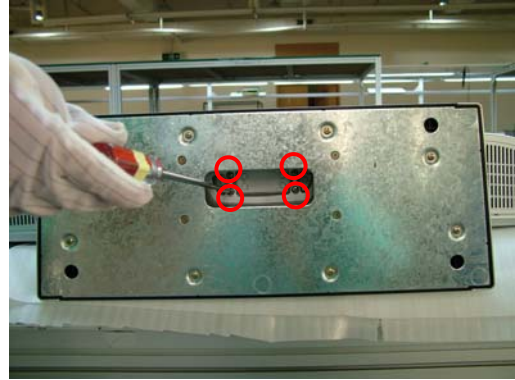

Figure 4

Disassembly Procedure

1. Disassembly of Stand and Dust Cover from LCD TV.

1.1 Unscrew 4 screws that secure Stand Unit.



1.2 Detach Stand Unit from the LCD TV.



Stand

1.3 Detach Dust Cover from the LCD TV.

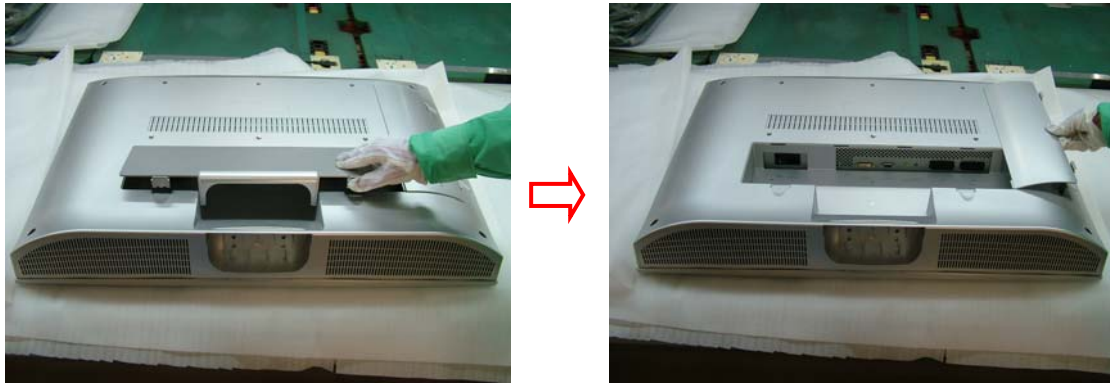

Dust Cover



Dust Cover



2. Disassembly of Rear Cover.

2.1 Unscrew 16 screws to remove Rear Cover.

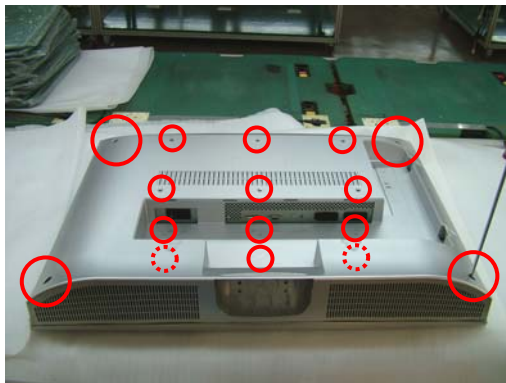

Rear Cover

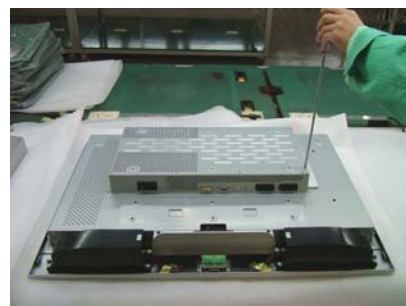

3. Disassembly of Main Board, Power Board, Keypad,IR Board,Speaker,Front Cover and Panel Unit.

3.1 Unscrew 14 screws to remove Shielding Plate.

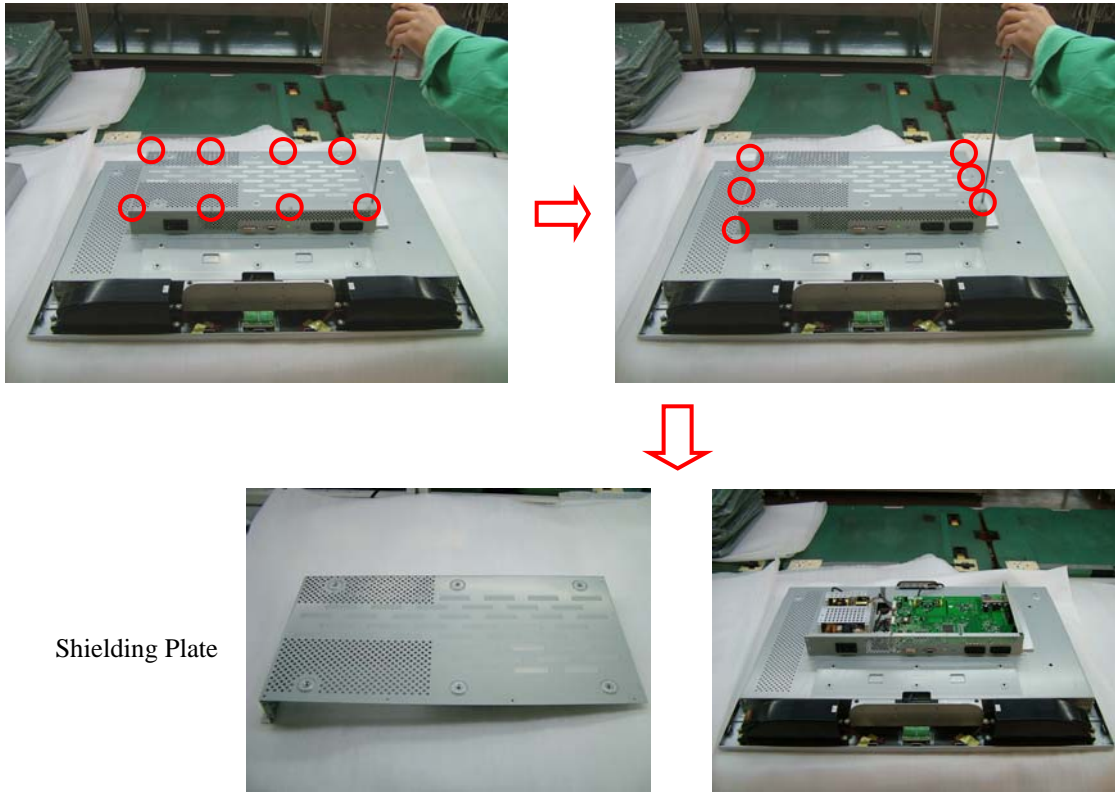

3.2. Unscrew 3 screws to remove Dust Cover.

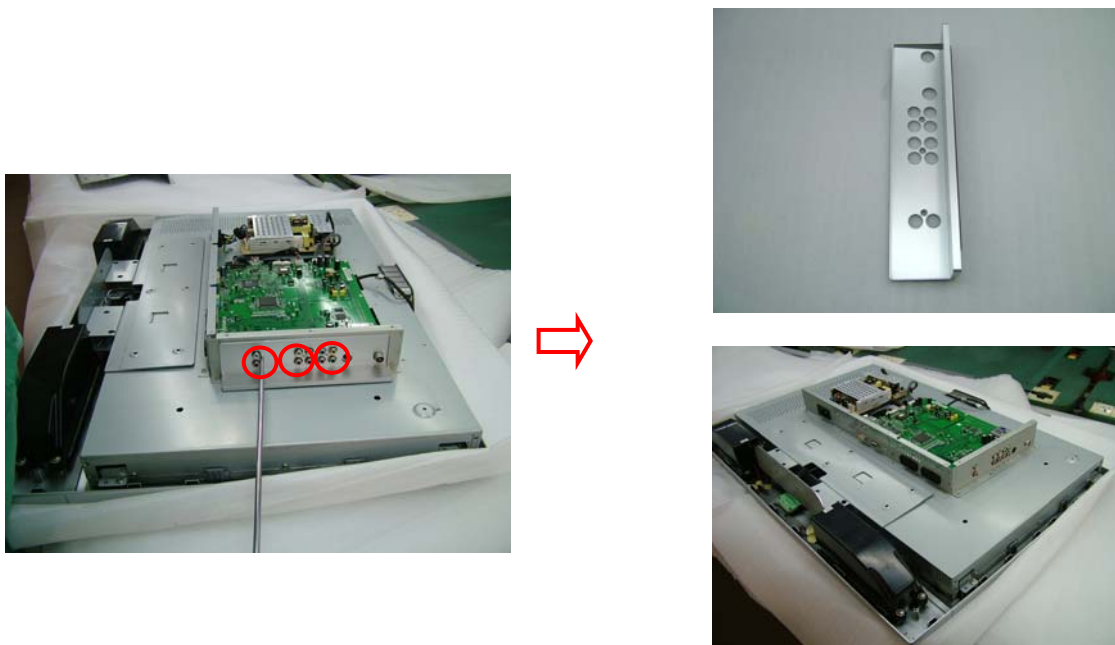

3.3. Unscrew 3 screws to remove Metal Fittg.



3.4. Unscrew 10 screws to remove Metal Fittg.

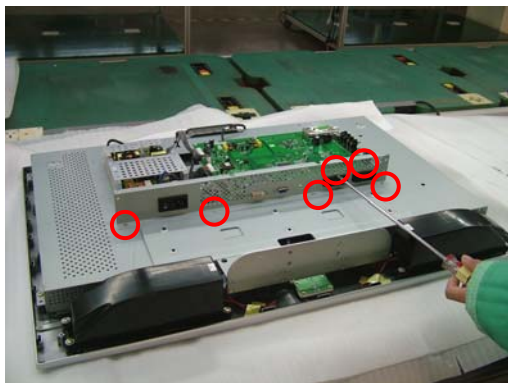

3.5. Unscrew 4 screws and disconnect the wires to remove Main Board.

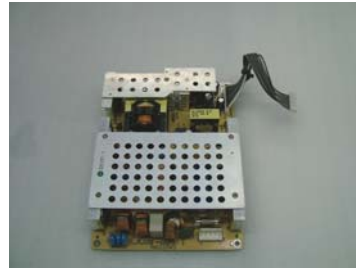
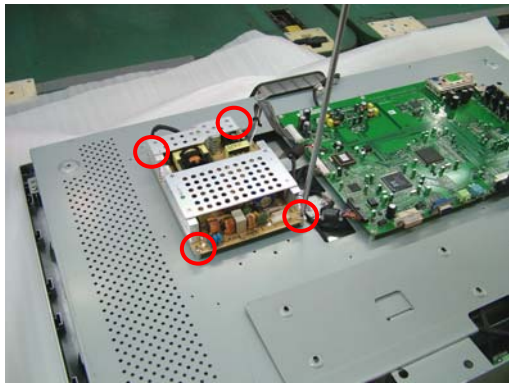

Main Board

3.6. Unscrew 6 screws and disconnect the wires to remove Power Board.

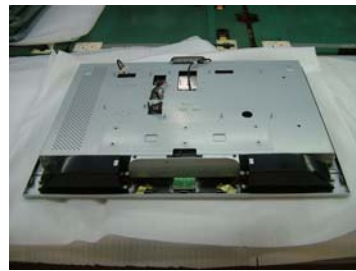
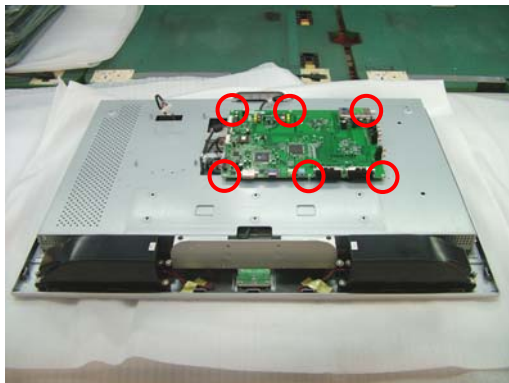

Power Board

3.7. Unscrew 6 screws and disconnect the wires to remove KeyPad.





Keypad Board

3.8. Unscrew 8 screws to remove Speaker.

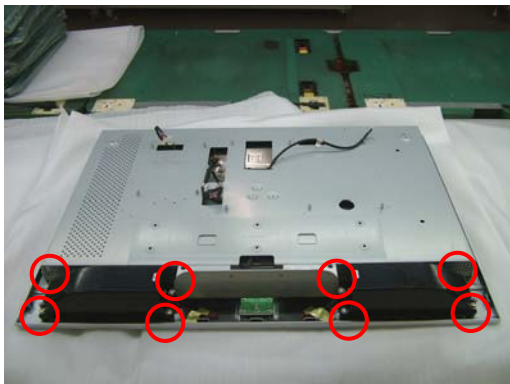

Speaker

3.9. Unscrew 6 screws to remove Bracket.



Bracket

3.10. Unscrew 6 screws to remove Front Cover.

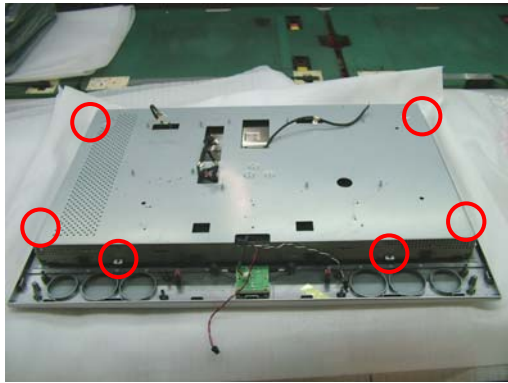

Front Cover

3.11. Unscrew 4 screws to remove IR Board.

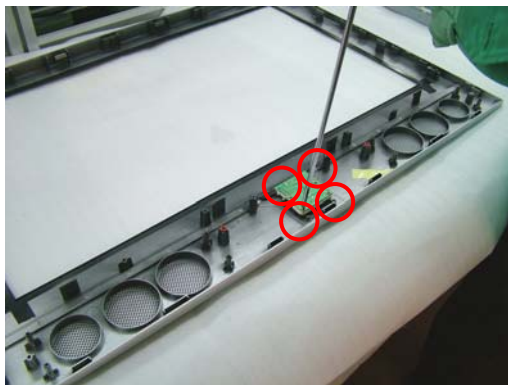

IR Board

3.12. Lay Panel Unit facedown and unscrew 6 screws on its right and left sides, to remove Panel Unit and Panel Bracket.



Panel Bracket



Panel Unit



6. Troubleshooting Flow Chart

11.1. NO POWER

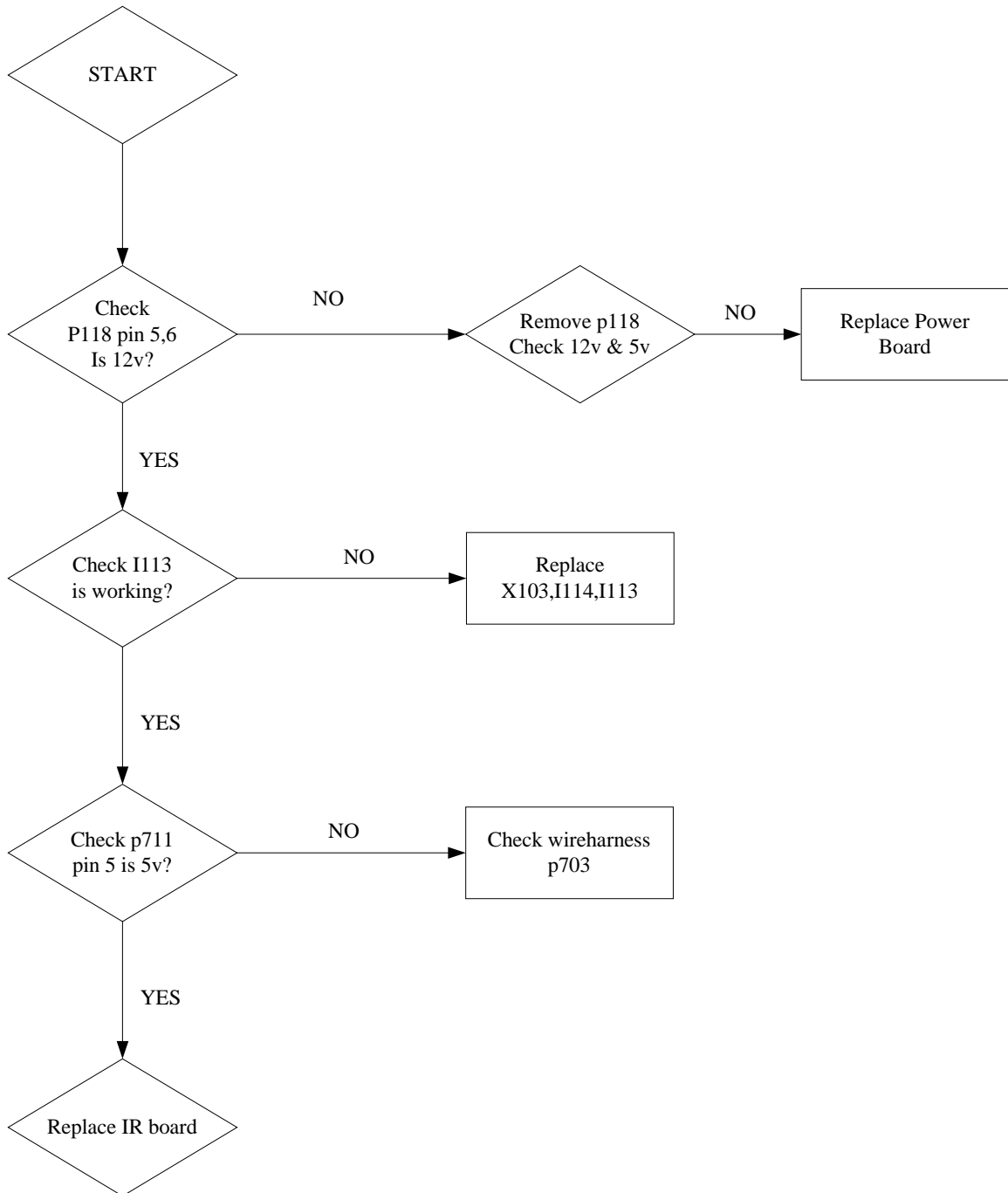

11.2. NO VOICE

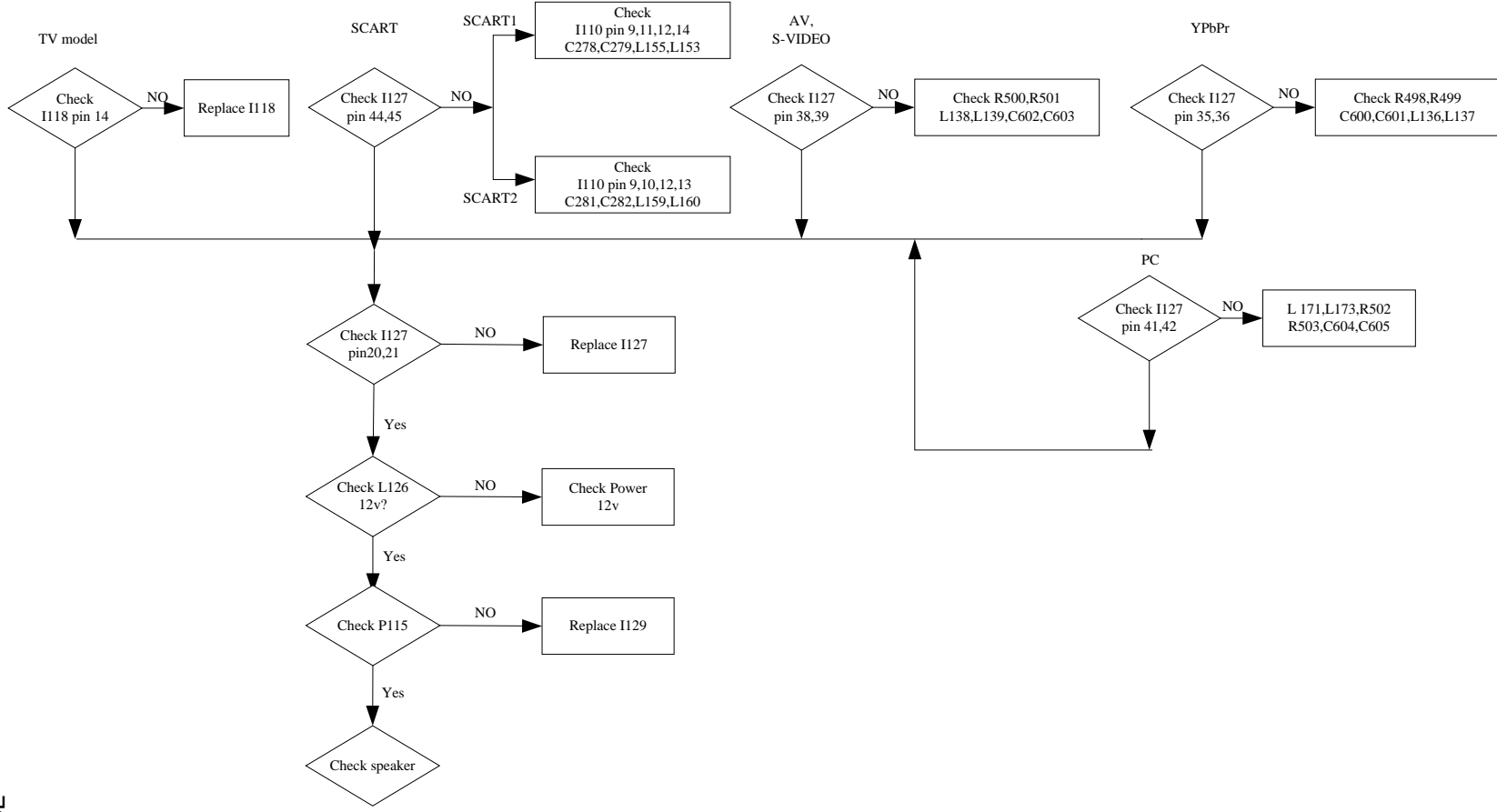

11.3. NO DISPLAY

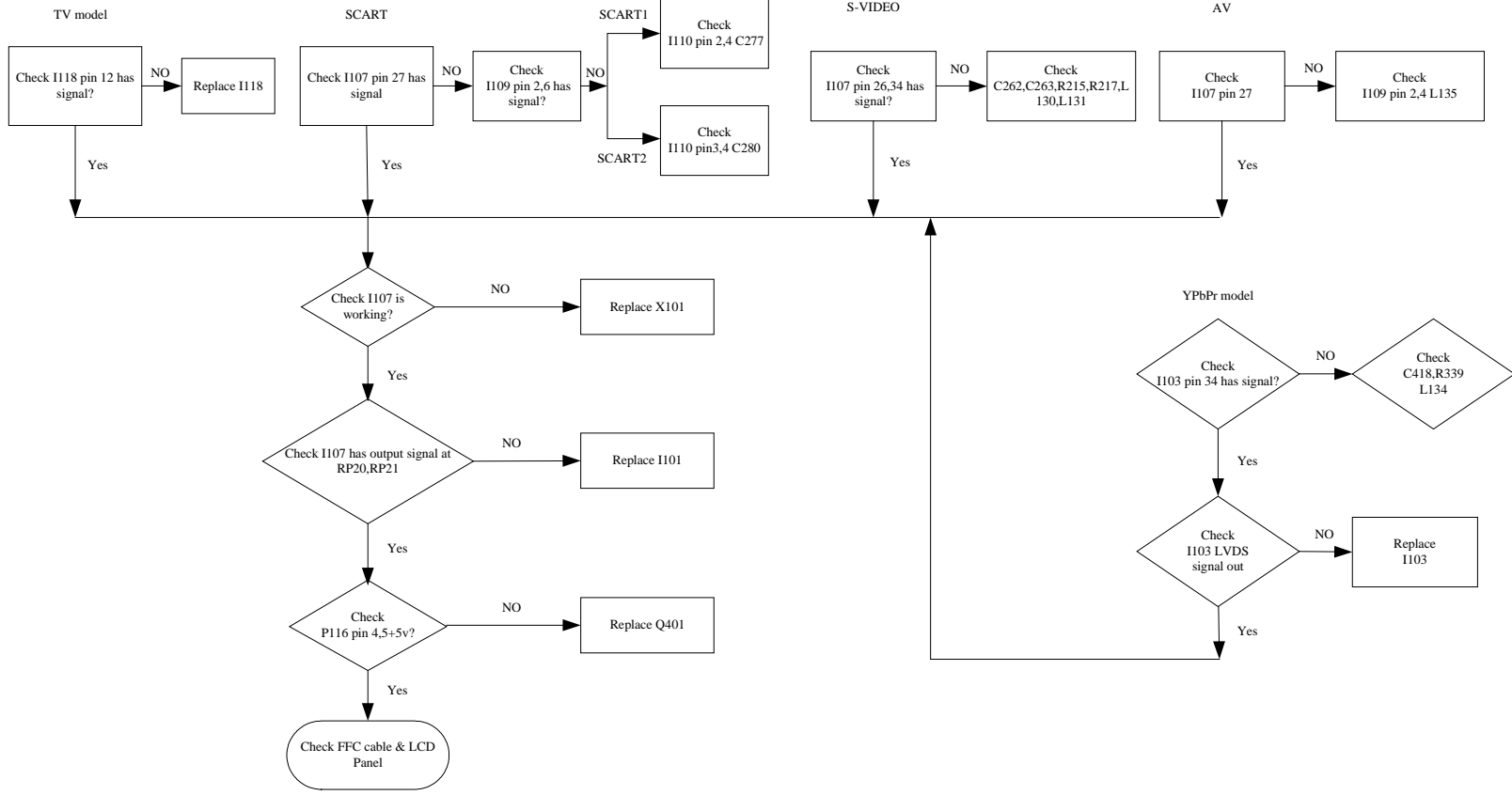

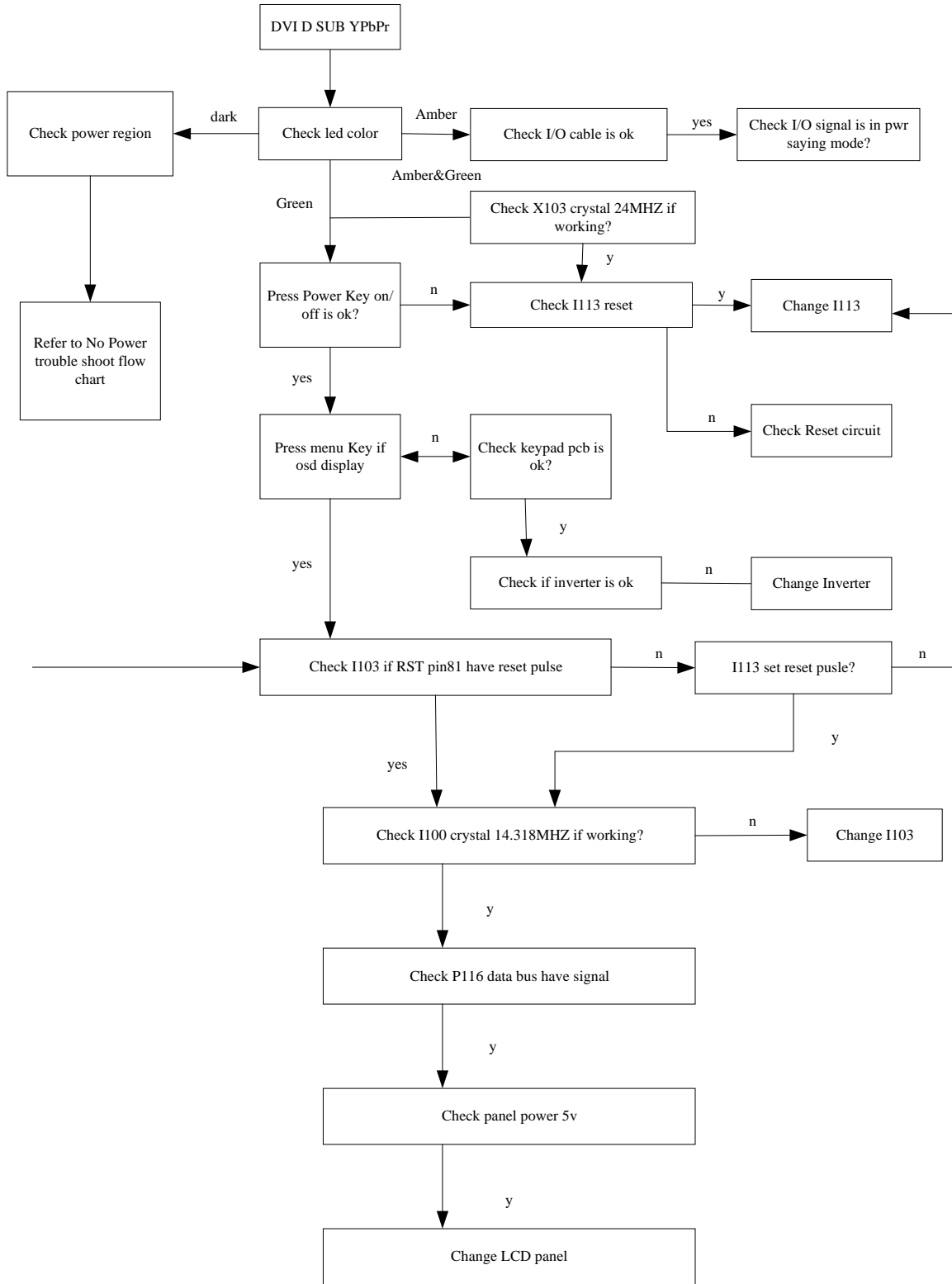

7. Exploded View

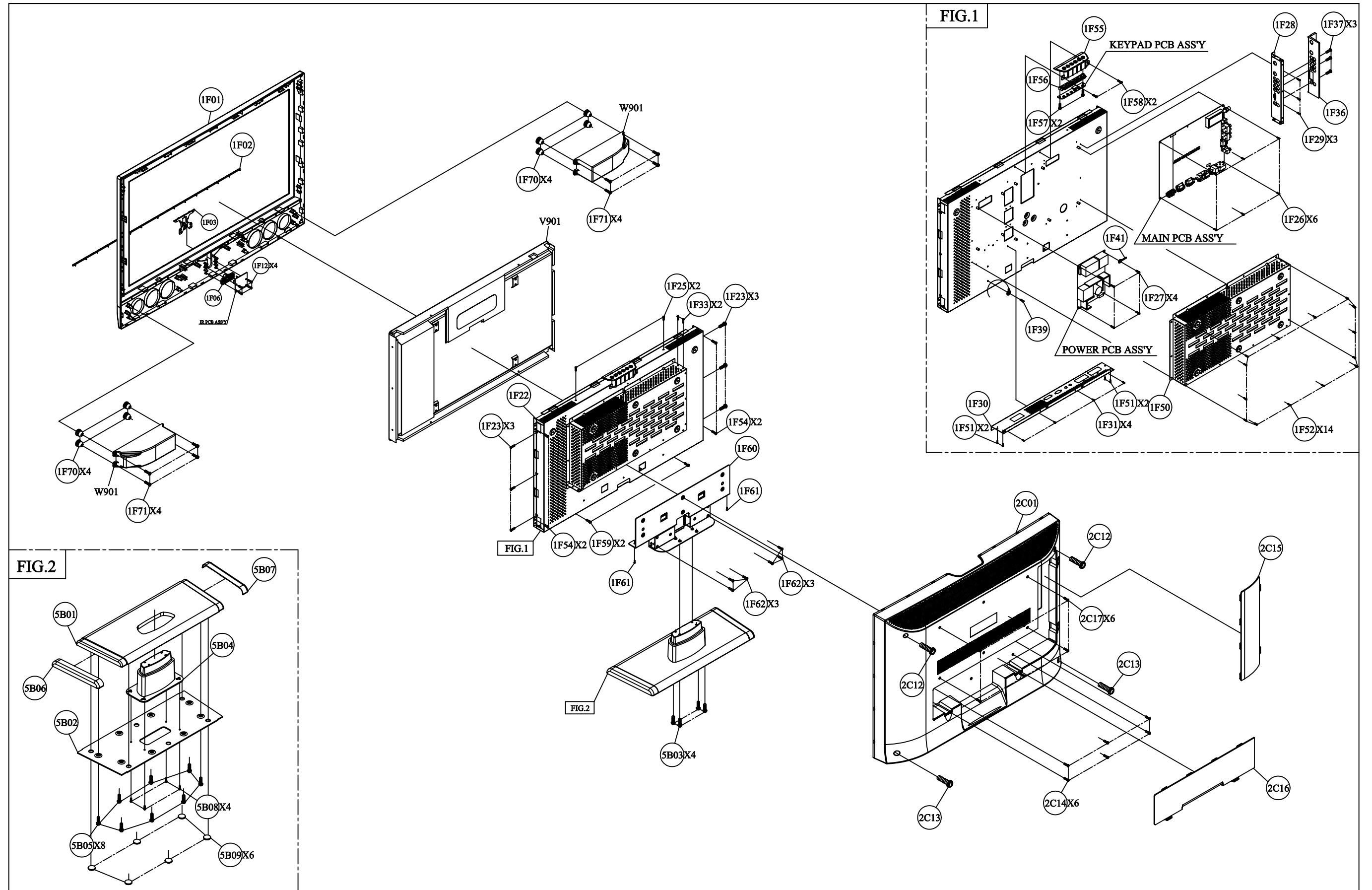

EXPLODED PARTS LIST (N3250w-1G)

ViewSonic Model Number: VS10769-1G

Rev: 1a

Serial No. Prefix: PS6

Item	ViewSonic P/N	Ref.P/N	Description		Q'ty
1F01	#N/A	2024268203	FRONT BEZEL	ABS 94HB BLACK/PS-7604B(V.S)	1
1F02	#N/A	2054256101	ORNAMENT	ABS 94HB AL-PLATE	1
1F03	#N/A	2033150600	IR COVER	JC278UB PC LIMPID 476C	1
1F06	#N/A	2044266901	FUNCTION KEY	JC278UB ABS 94V0 AL-PLATE PWR	1
1F12	M-SCW-0824-0285	2084730082	SCREW,BND T+	M3X8(BND T+)	4
1F22	#N/A	2071972200	METAL FITTG	SECC T=1.0MM FOR AU PANEL	1
1F23	#N/A	2082740082	SCREW,BND+	M4X8(BND+)	6
1F25	#N/A	2082740082	SCREW,BND+	M4X8(BND+)	2
1F26	M-SCW-0824-0811	2080003700	SCREW,SPE	1SZZTER001A M3*6L SWR17/FZMY1	6
1F27	M-SCW-0824-0811	2080003700	SCREW,SPE	1SZZTER001A M3*6L SWR17/FZMY1	4
1F28	#N/A	2072051000	METAL FITTG-I/O	SECC T=1.0MM FOR EURO	1
1F29	#N/A	2082630042	SCREW	M3*4 P=0.5	3
1F30	#N/A	2072050800	METAL FITTG-I/O	SECC T=1.0MM FOR EURO	1
1F31	#N/A	2082630042	SCREW	M3*4 P=0.5	4
1F33	M-SCW-0824-6719	2082630062	SCREW	M3X6 P=0.5	2
1F36	#N/A	2027259801	DUST COVER	ABS 94HB PS-7604B FOR EURO	1
1F37	#N/A	2083730102	SCREW,BND T+	SCREW BND T+	3
1F39	#N/A	2080040062	SCREW,SPE	M4*8 PMS-3/W	1
1F40	#N/A	2061254000	SPONGE	SPONGE BLACK 10*6*180MM	1
1F41	#N/A	2071800300	BRACKET,FIX	62*8*3.4 T=0.5MM WITH PVC TUBE	1
1F50	#N/A	2071972400	METAL FITTG	SECC T=1.0MM VESA SUPPORT	1
1F51	#N/A	2083630068	SCREW FMS+	M3X6,M,S-TITE,F,NI	4
1F52	#N/A	2082630042	SCREW	M3*4 P=0.5	14
1F54	#N/A	2084740122	SCREW,BND T+	M4X12(BND T+)	4
1F55	#N/A	2027259601	DUST COVER	ABS 94HB PS-7604B	1
1F56	#N/A	2044266601	FUNCTION KEY	JC278 ABS 94V0 AL-PLATE FUNCTI	1
1F57	M-SCW-0824-0285	2084730082	SCREW,BND T+	M3X8(BND T+)	2
1F58	M-SCW-0824-6719	2082630062	SCREW	M3X6 P=0.5	2
1F59	M-SCW-0824-6721	2084740082	SCREW,BND T+	M4X8(BND T+)	2
1F60	#N/A	2071871400	BRACKET,FIX	SECC T=2.0MM FIX ARM	1
1F61	#N/A	2086240122	SCREW,P SW+	M4*12 PSW+	2
1F62	#N/A	2084740122	SCREW,BND T+	M4X12(BND T+)	6
1F70	#N/A	2090106700	WASHER,METAL	f 12xf 4.5x1.5t SECC	8
1F71	#N/A	2084740122	SCREW,BND T+	M4X12(BND T+)	8
2C01	#N/A	2022262901	CABI BACK	ABS 94HB PS-7604B (EURO)	1
2C12	#N/A	2082740082	SCREW,BND+	M4X8(BND+)	2
2C13	#N/A	2084740122	SCREW,BND T+	M4X12(BND T+)	2
2C14	#N/A	2082340102	SCREW,CSK+	SCREW F M4X10 (CSK+)	6
2C15	#N/A	2027259901	DUST COVER	ABS 94HB PS-7604B	1
2C16	#N/A	2027260001	DUST COVER	ABS 94HB PS-7604B	1
2C17	#N/A	2080005901	SCREW,SPE	M6*10MM TYPE"1" NI	6
5B01	#N/A	2071871700	BRACKET,FIX	JC278UB ALUMINUM PS-7604B ARM	1
5B02	#N/A	2071871601	BRACKET,FIX	JC32UB SGCC T=3.0MM STAND	1
5B03	#N/A	2082340102	SCREW,CSK+	SCREW F M4X10 (CSK+)	4
5B04	PL-00003417	2028258801	STAND	JC278UB ABS 94HB PS-7604B	1
5B05	M-SCW-0824-0123	2084740102	SCREW,BND T+	M4X10(BND T+)	8
5B06	#N/A	2054256201	ORNAMENT	JC278UB BASE PLATE LEFT	1
5B07	#N/A	2054256301	ORNAMENT	JC278UB BASE PLATE RIGHT	1
5B08	#N/A	2082750402	SCREW,BND+	M5X40,M,P,ZN-CC	4
5B09	PL-PD-0714-0113	2039819301	FOOT PAD	RUBBER O20*2TMM SQUARE RAIN	6

8. Recommended Spare Parts List

RECOMMENDED SPARE PARTS LIST (N3250w-1M)

ViewSonic Model Number: VS10769-1M

Rev: 1b

Serial No. Prefix: PS4

Item	Description	ECR/ECN	ViewSonic P/N	Ref.P/N	Location	Q'ty
1	Accessories:					
	POWER CORD USA WALL 1.83M BLACK		A-00003561	2427130046	P951	1
2	REMOTE CONTROL N3250W VIEWSONIC UBRC-100		A-00003562	2419200025	H901	1
3	Board Assembly:					
	PCB ASS'Y BLOCK (MAIN)		B-00003563	6201-7032146381		1
4	PCB ASS'Y BLOCK (CON)		B-00003564	6202-7032146381		1
5	PCB ASS'Y BLOCK (IR)		B-00003565	6206-7032146381		1
6	Cabinets:					
	CABI BACK ABS 94HB BLACK		C-00003566	2022262902	2C01	1
7	BEZEL ASS'Y ABS 94HB BLACK (VIEWSONIC)		C-00003567	2603307787		1
8	Cables:					
	I/O CABLE D15/D15 20276(3+6) 1.83M BLACK		CB-00003568	2427501187	P961	1
9	CABLE RCA 3P(Y/R/W) 2562#26 1.8M BLK		CB-00003425	2427701893	P955	1
10	Documentation:					
	OWNER GUIDE N3250W VS10769-1M USA		DC-00003569	2001131365	6P80	1
11	GUARANT CARD VIEWSONIC N3250W QSG USA		DC-00003570	2002310470	6P81	1
12	Electronic Components:					
	LCD PANEL T315XW01 V2		E-00003571	2212008100	V901	1
13	Hardware:					
	BRACKET, FIX JC278 BASE ALUMINUM BLACK 4001		HW-00003572	2071870401	5B01	1
14	Packing Material:					
	CARTON BOX VIEWSONIC N3250W VS10769-1M		P-00003573	2011132502	6P01	1
15	POLYFOAM EPE (R)		P-00003574	2012178700	6P20	1
16	POLYFOAM EPE (L)		P-00003575	2012178800	6P21	1
17	POLYFOAM EPE (DOWN)		P-00003576	2012178900	6P22	1

ViewSonic Model Number: VS10769-1G

BOM LIST (N3250w-1G)

Rev: 1a

Serial No. Prefix: PS6

Item	ViewSonic P/N	Ref. P/N	Description	Location	Universal number#	Qty
1	C-00004495	2024268203P	FRONT BEZEL 32UB ABS HB BLK C/PS-7604B(VSC	1F01		1
2	#N/A	2054256101P	ORNAMENT IC32 FRONT BAR ABS HB AL-PLATE	1F02		1
3	#N/A	2033150600P	IR COVER JC278UB PC LIMPID 476C	1F03		1
4	#N/A	2053754201P	LED INDIC.-PWR JC278UB PMMA LIMPID	1F04		1
5	#N/A	2044266901P	FUNCTION KEY JC278UB ABS 94V0 AL-PLATE PWR	1F06		1
6	#N/A	2071972200P	METAL FITTG SECC T=1.0MM FOR AU PANEL	1F22		1
7	#N/A	2082740082P	SCREW,BND+ M4X8(BND+)	1F23 1F25 2C12		10
8	M-SCW-0824-0811	2080003700P	SCREW,SPE ISZZTER001A M3*6L MSWR17/FZMYI	1F26 1F27 1F38		16
9	#N/A	2072051000P	METAL FITTG-I/O SECC T=1.0MM FOR EURO	1F28		1
10	#N/A	2082630042P	SCREW M3*4 P=0.5	1F29 1F31 1F52		21
11	#N/A	2072050800P	METAL FITTG-I/O SECC T=1.0MM FOR EURO	1F30		1
12	#N/A	2083630068P	SCREW FMS+ M3X6,M.S-TITE,F,NI	1F32 1F51		7
13	M-SCW-0824-6719	2082630062P	SCREW M3X6 P=0.5	1F33 1F58		4
14	C-00004494	2027259801P	DUST COVER JC32 ABS HB PS-7604B (E)	1F36		1
15	#N/A	2083730102P	SCREW,BND T+ SCREW BND T+	1F37		3
16	#N/A	2080040062P	SCREW,SPE M4*8 PMS-3/W	1F39		1
17	#N/A	2061254000P	SPONGE SPONGE BLACK 10*6*180MM	1F40 2C02		2
18	#N/A	2071800300P	BRACKET,FIX 62*8*3.4 T=0.5MM WITH PVC TUBE	1F41		1
19	#N/A	2071972400P	METAL FITTG SECC T=1.0MM VESA SUPPORT	1F50		1
20	#N/A	2084740122P	SCREW,BND T+ M4*12 (BND T+)	1F54 1F62 1F71 2C13		20
21	C-00004491	2027259601P	DUST COVER JC32 ABS HB PS-7604B	1F55		1
22	#N/A	2044266601P	FUNCTION KEY JC278 ABS 94V0 AL-PLATE FUNCTI	1F56		1
23	M-SCW-0824-0285	2084730082P	SCREW,BND T+ M3X8(BND T+)	1F57 1F12 1F59		8
24	#N/A	2071871400P	BRACKET,FIX SECC T=2.0MM FIX ARM	1F60		1
25	#N/A	2086240122P	SCREW,P SW+ M4*12 PSW+	1F61		2
26	#N/A	2090106700P	WASHER,METAL f 12xf 4.5x1.5t SECC 8.	1F70		0
27	C-00004490	2022262901P	CABI BACK JC32 ABS HB PS-7604B(E)	2C01		1
28	#N/A	2061254001P	SPONGE SPONGE BLACK 20*15*50MM	2C03		2
29	#N/A	2061151900P	FELT 267*12.7=0.5MM NO.5000NS	2C04		2
30	C-00004492	2027259901P	DUST COVER-RIG/JC32 ABS HB PS-7604B (R)	2C15		1
31	C-00004493	2027260001P	DUST COVER-DOV/JC32 ABS HB PS-7604B (D)	2C16		1
32	#N/A	2080005901P	SCREW,SPE M6*10MM TYPE"TI" NI	2C17		6
33	#N/A	2071871700P	BRACKET,FIX JC278UB ALUMINUM PS-7604B ARM	5B01		1
34	#N/A	2071871601P	BRACKET,FIX JC32UB SGCC T=3.0MM STAND	5B02		1
35	#N/A	2082340102P	SCREW,CSK+ SCREW F M4X10 (CSK+)	5B03 2C14		10
36	PL-00003417	2028258801P	STAND JC278UB ABS 94HB PS-7604B	5B04		1
37	M-SCW-0824-0123	2084740102P	SCREW,BND T+ M4X10(BND T+)	5B05		8
38	#N/A	2054256201P	ORNAMENT JC278UB BASE PLATE LEFT	5B06		1
39	#N/A	2054256301P	ORNAMENT JC278UB BASE PLATE RIGHT	5B07		1
40	#N/A	2082750402P	SCREW,BND+ M5X40,M,P,ZN-CC	5B08		4
41	PL-PD-0714-0113	2039819301P	FOOT PAD RUBBER O20*2TMM SQUARE GRAIN	5B09		6
42	#N/A	2011132505P	CARTON BOX VIEWSONIC N3250W(G) VS10769-1G	6P01		1
43	#N/A	2055632167P	LABEL N3250W VS10769-1G (G) AUO	6P02		1
44	#N/A	2055636040P	LABEL N3250W VS10769-1G SMALL LABEL	6P05		1
45	DC-00003461	2002310402P	GUARANT CARD VIEWSONIC WARRANTY CARD-C 2004	6P07		1
46	M-LB-0813-0862	2056606025P	SERIAL LABEL VS CN WARRANTY CARD SN STICKER	6P08		2
47	M-LB-0813-0984	2002201323P	DISPLAY CARD VIEWSONIC CRT QUALIFIED LABEL	6P09		1
48	M-LB-0813-0856	2055613379P	LABEL VIEWSONIC CONTAINER LABEL	6P11		1/6
49	M-LB-0813-0863	2056606010P	SERIAL LABEL VIEWSONIC BOX STICKER-G	6P12		1
50	M-LB-0813-0530	2055617101P	LABEL 10*20 HI-POT TESTED OK	6P13		1
51	M-LB-0813-0959	2055613392P	LABEL VSC HIGH VOLTAGE WARNING LABEL	6P14		1
52	M-LB-0813-0864	2056606009P	SERIAL LABEL VIEWSONIC SERVICE STICKER-G	6P15		1
53	#N/A	2012184000P	POLYFOAM UB/EC TOP(R) EPE	6P20		1
54	#N/A	2012184100P	POLYFOAM UB/EC TOP(L) EPE	6P21		1
55	#N/A	2012184200P	POLYFOAM UB DOWN EPE	6P22		1
56	#N/A	2055135049P	LABEL N3250W VS10769-1G AUO CHINA	6P50		1
57	M-LB-0813-0528	2055103400P	LABEL JK0936F WEN	6P52		1
58	M-LB-0813-0002	2056603050P	SERIAL LABEL VIEWSONIC LCD SERIAL LABEL	6P56 6P54 6P55 6P51		4
59	#N/A	2013054007P	POLYETHY BAG 870*800MM HDPE BAG	6P60		1
60	#N/A	2013054013P	POLYETHY BAG 950LX400WX1200H T=0.08MM	6P70		1
61	#N/A	2001131435P	OWNER GUIDE VSC N3250W VS10769-1G CHINA	6P80		1
62	DC-00004496	2002310515P	GUARANT CARD VIEWSONIC N3250W(G) QSG	6P81		1
63	P-00004497	2011100017P	CARTON BOX 360X220X50mm (WXDXH) BOX(B)	6P85		1
64	M-MS-0808-1316	2013222536P	POLYETHY BAG 250mmX350mmX0.3t ADD>PE-LD<	6P86		1
65	#N/A	2074750100P	LED HOLDER-PWF NYLON 66 H=6.0MM LED306	9R81		1
66	#N/A	2005100400P	BATTERY DRY R6PGS 1.5V (AA) CHINA TOSHIBA	B901		2
67	#N/A	2710125100	MANUAL INSERT- N3250(G)	BA42		1
68	#N/A	2720125100	V-TYPE-MAIN N3250W(G)	BA52		1
69	#N/A	2702225100	PCB-CON N3250W(G)	BB31		1
70	#N/A	2710625100	MANUAL INSERT- N3250W(G)	BB42		1
71	E-C-0404-4424	2346110396P	CAP,CHIP 125°C CS 0603/X7R/50V 0.01u K T	C100 C101 C104 C424 C517 C627 C686 C687		8
72	#N/A	2349900996P	CAP,CHIP SPEC 0603V-PORT 10P+-10% INPAQ	C102 C103 C106C12 C113 C114 C115 C119 C408 C409 C420 C421 C422 C243 C471 C472 C473 C474 C475 C490 C491 C492 C493 C494		24

Item	ViewSonic P/N	Ref. P/N	Description	Location	Universal number#	Q'ty
73	#N/A	2346147396P	CAP,CHIP 125°C CS 0603/X7R/50V 0.047u K T	C105 C107 C108 C109 C10 C111 C417 C418 C419 C425 C426 C427		12
74	#N/A	2341112096P	CAP,CHIP 125°C CS 0603/COG/50V 12p J T	C116 C117 C118		3
75	#N/A	2336310713P	CAP,MINI ELE 105'EC 100u/ 16V 6.3*7 P=2.5 T	C125 C127 C275 C276 C277 C280 C488 C489 C713 C720 C726 C730 C733		13
76	#N/A	2346110496P	CAP,CHIP 125°C CS 0603/X7R/50V 0.1u K T	C120 C128 C129 C131 C133 C134 C136 C137 C139 C141 C142 C143 C144 1C45 C146 C147 C148 C149 C151 C154 C155 C156 C158 C159 C160 C161 C162 C163 C165 C166 C167 C168 C169 C170 C180 C181 C182 C183 C184 C185 C186 C187 C188 C189 C190 C192 C193 C194 C195 C196 C197 C206 C207 C208 C209 C210 C212 C214 C215 C216 C217 C218 C219 C220 C221 C226 C227 C231 C234 C235 C236 C237 C238 C239 C240 C241 C244 C245 C246 C247 C252 C253 C254 C255 C256 C261 C262 C263 C270 C274 C376 C380 C382 C383 C384 C385 C386 C387 C388 C389C390 C482 C485 C513 C529 C611 C619 C620 C624 C642 C651 C660 C663 C668 C677 C765 C701 C702C712 C715 C716 C721 C722 C723 C724 C725		127
77	#N/A	2341130096P	CAP,CHIP 125°C CS 0603/COG/50V 30p J T	C130 C132		2
78	#N/A	2336610613P	CAP,MINI ELE 105'EC 10u/ 50V 5*7 P=2.5 T	C135 C138 C140 C150 C152 C153 C157 C164 C178 C204 C213 C229 C232 C379 C612 C613 C615 C616 C621 C622 C623 C683 C684		23
79	#N/A	2336322613P	CAP,MINI ELE 105'EC 22u/ 16V 4*7 P=2.5 T	C179 C191 C269 C483 C486 C631 C632 C634 C635		9
80	E-00000999	2336347613P	CAP,MINI ELE 105'EC 47u/ 16V 5*7 P=2.5 T	C205 C211 C225 C233 C381 C518 C641 C703 C724 C725		10
81	#N/A	2341120096P	CAP,CHIP 125°C CS 0603/COG/50V 20p J T	C222 C223 C377 C378		4
82	E-C-0404-3900	2341133096P	CAP,CHIP 125°C CS 0603/COG/50V 33p J T	C224 C736		2
83	#N/A	2346122396P	CAP,CHIP 125°C CS 0603/X7R/50V 0.022u K T	C228 C230 C242 C243		4
84	E-C-0404-4828	2341110196P	CAP,CHIP 125°C CS 0603/COG/50V 100p J T	C248 C249 C250 C251 C257 C258 C259 C264 C265 C266 C267 C268 C391 C640 C644		15
85	#N/A	2341147196P	CAP,CHIP 125°C CS 0603/COG/50V 470p J T	C272 C273 C522 C608 C609 C626		6
86	E-00003865	2346710596P	CAP,CHIP 85°C CS 0603/Y5V/16V 1.0u Z T	C278 C279 C281 C282 C600 C601 C602 C603 C604 C605 C606 C607 C610 C655 C656 C657 C658 C659 C678 C681 C682		21
87	#N/A	2333610613P	CAP ELE 105°C EC 10u/ 50V 5*11 P=2.5 T	C392 C652 C661 C664 C669 C673C676 C734		8
88	#N/A	2349901096P	CAP,CHIP SPEC AC0603470A 47p±10% INPAQ	C430 C431 C432 C433 C458 C463 C477 C479 C480 C481 C484 C487 C496 C502 C503 C504C505 C506		18
89	#N/A	2335215811P	CAP,ELE LOW ESREC 1500u/ 10V10*16 P=5.0 C	C514 C521		2
90	#N/A	2341110296P	CAP,CHIP 125°C CS 0603/COG/50V 1000p J T	C519 C638 C639		3
91	#N/A	2346415496P	CAP,CHIP 85°C CS 0603/Y5V/50V 0.15u Z T	C614		1
92	E-C-0404-4829	2341122196P	CAP,CHIP 125°C CS 0603/COG/50V 220p J T	C617 C671		2
93	#N/A	2341139196P	CAP,CHIP 125°C CS 0603/COG/50V 390p J T	C618		1
94	#N/A	2341168196P	CAP,CHIP 125°C CS 0603/COG/50V 680p J T	C625		1
95	#N/A	2341156096P	CAP,CHIP 125°C CS 0603/COG/50V 56p J T	C628 C629 C633		3
96	E-C-0404-4225	2346139296P	CAP,CHIP 125°C CS 0603/X7R/50V 3900p K T	C630		1
97	#N/A	2341182996P	CAP,CHIP 125°C CS 0603/COG/50V 8.2p D T	C636 C637		2
98	#N/A	2333310801P	CAP ELE 105°C EC 1000u/ 16V10*17 P=5.0 C	C653 C704		2
99	#N/A	2347110396P	CAP,CHIP 125°C CS 0805/X7R/50V 0.01u K T	C654 C666 C667 C675		4
100	#N/A	2301310591P	CAP MEB MEB 1.0u/ 63V P=5.0 J T	C662 C665 C670 C674		4
101	#N/A	2336610513P	CAP,MINI ELE 105'EC 1u/ 50V 4*7 P=2.5 T	C679 C680		2
102	E-C-0404-3816	2347110296P	CAP,CHIP 125°C CS 0805/X7R/50V 1000p K T	C688 C689N C690 C691		4
103	E-C-0404-3096	2335310812P	CAP,ELE LOW ESREC 1000u/ 16V 10*20 P=5.0 K	C714 C719		2
104	#N/A	2336622513P	CAP,MINI ELE 105'EC 2.2u/ 50V 4*7 P=2.5 T	C738 C643		2
105	#N/A	2340722008P	CAP.ARRAY P=0.8 1206Y5V 22.000PF 16V M 8P	CP01 CP02		2
106	E-D-0403-1779	2364503996P	DIODE,ZENER SMIBZV55-C5V6 5% SOD-80C PHILIPS	D100 RA D101 RA D104 RA		3

Item	ViewSonic P/N	Ref. P/N	Description	Location	Universal number#	Q'ty
107	E-D-0403-1666	2364500396P	DIODE,ZENER SMIRLZ5.6B 5.45-5.73V LL-34 ROHM	D100 RB D101 RB D104 RB		3
108	#N/A	2364505636P	DIODE,ZENER SMIBZV55-B5V6 2% SOD-80C PHILIPS	D100 RC D101 RC D104 RC		3
109	#N/A	2364600496P	DIODE,SWITCH SA MM4148 SOD-80 GRANDE	D102 RA D103 RA D105 RA D106 RA D107 RA D112 RA D113 RA		7
110	E-D-0403-1892	2364200896P	DIODE,RECT(SMD BAS32L SOD80C PHILIPS	D102 RB D103 RB D105 RB D106 RB D107 RB D112 RB D113 RB		7
111	E-00003830	2364601396P	DIODE,SWITCH SA 1N4148W-7-F SOD-123 DIODES	D102 RC D103 RC D105 RC D106 RC D107 RC D112 RC D113 RC		7
112	E-00003534	2363600696P	DIODE,SWITCH RLS4148-T11 SOD-80 ROHM	D102 RD D103 RD D105 RD D106 RD D107 RD D112 RD D113 RD		7
113	#N/A	2363705101P	LED L-3WEGW KINGBRIGHT	D721		1
114	A-00004438	2419200047P	CONT BLOCK N3250W(G) VinewSonic CHINA	H901		1
115	#N/A	2365104000P	MEMORY IC 24LC22A-I/P PDIP-8 MICROCHIP	I100		1
116	E-IC-0401-2017	2365412600P	DIGITAL IC 24LC21A/P PSDIP-8 MICROCHIP	I101		1
117	#N/A	2365814996P	IC,LINEAR(SMD) AP1084K18LA TO-263 AnaChip	I102 RA		1
118	#N/A	2365810196P	IC,LINEAR(SMD) AIC1084-18CM TO-263 AIC	I102 RB		1
119	#N/A	2365335156P	LINEAR IC OB1084CLP(1.8V) TO-263 LITEON	I102 RC		1
120	#N/A	2365425096P	DIGITAL IC MST5151LA-LF LQFP-256 Mstar	I103		1
121	#N/A	2365104396P	MEMORY IC NT5DS4M32EG FBGA-144 NANYA	I105 RA		1
122	#N/A	2365105796P	MEMORY IC (SDR,EM6A9320BI-5MG FBGA144 Ettron	I105 RB		1
123	E-IC-0401-2924	2365808196P	IC,LINEAR(SMD) AP1117E33LA SOT-223 AnaChip	I106 RA		1
124	#N/A	2365808396P	IC,LINEAR(SMD) AIC1117-33PY SOT-223 AIC	I106 RB		1
125	#N/A	2365809496P	IC,LINEAR(SMD) CM1117SCM-3.3V SOT223 CHAMPION	I106 RC		1
126	#N/A	2365425066P	DIGITAL IC SAA7117AH QFP-160 PHILIPS	I107		1
127	#N/A	2365104700P	IC,LINEAR(SMD) AP1117E18LA SOT-223 AnaChip	I108 RA		1
128	#N/A	2365335086P	LINEAR IC AIC1117A-18PY SOT223 AIC	I108 RB		1
129	#N/A	2365335216P	LINEAR IC MM1501XNRE SOT-26B MITSUMI	I109		1
130	#N/A	2365915796P	IC,DIGITAL SMD ADG774BRQ QSOP-16 ADI	I110 RA		1
131	E-00003530	2365813796P	IC,LINEAR(SMD) TS5V330DBQR SSOP-16 TI	I110 RB		1
132	#N/A	2365931896P	IC,DIGITAL SMD FSAV330QSCX QSOP-16 FAIRCHILD	I110 RC		1
133	#N/A	2365425016P	DIGITAL IC W79E632A40PL PLCC-44 Winbond	I113		1
134	#N/A	2365104700P	MEMORY IC AT24C32A-10PU-2.7 PDIP-8 ATMEL	I114 RA		1
135	#N/A	2365102800P	IC,MEMORY (EEP)M24C32-WBN6P PDIP-8 ST	I114 RB		1
136	#N/A	2365105600P	MEMORY IC HT24LC04 DIP-8 HOLTEK	I115 RA		1
137	#N/A	2365416900P	DIGITAL IC AT24C04-10PC-2.7 SOIC-8 ATMEL	I115 RB		1
138	#N/A	2365105900P	MEMORY IC (EEP)AT24C04-10PU-2.7 PDIP-8 ATMEL	I115 RC		1
139	#N/A	2416901900P	UV TUNER FQ1216ME/IH-5 PHILIPS	I118 RA		1
140	E-00003954	2416901800P	UV TUNER TAPE-S701D (J) LG	I118 RB		1
141	#N/A	2365930296P	IC,DIGITAL SMD MSP3410G-QI-B8V3 Micronas	I127 RA		1
142	#N/A	2365425176P	DIGITAL IC MSP3410G-QI-C12-001 Micronas	I127 RB		1
143	#N/A	2365335246P	LINEAR IC TPA3004D2PHPRG34 HTQFP48 TI	I129		1
144	E-00000915	2360501196P	FET,P-CH SMD AP9435GM SO-8 APEC	I135 RA I136 RA		2
145	E-00000916	2360501596P	FET,P-CH SMD AO4405 SO-8 AOS	I135 RB I136 RB		2
146	#N/A	2360510196P	FET,P-CH SMD SI4953ADY-T1-E3 SO-8 VISHAY	I135 RC I136 RC		2
147	E-00003529	2360501796P	FET,P-CH SMD APM9435KC SO-8 Anpec	I135 RD I136 RD		2
148	#N/A	2365813096P	IC,LINEAR(SMD) L78M08CDT-TR DPAK(TO-252) ST	I137		1
149	E-IC-0401-2745	2365810796P	IC,LINEAR(SMD) AP1084K33LA TO-263 ATC	I140 RA		1
150	E-IC-0401-2123	2365807496P	IC,LINEAR(SMD) AIC1084-33PM TO-263 AIC	I140 RB		1
151	#N/A	2365809196P	IC,LINEAR(SMD) CM1084SCN263 SO-263 CHAMPION	I140 RC		1
152	#N/A	2365811196P	IC,LINEAR(SMD) AP1117E25A(2.5V)SOT223 AnaChip	I141 RA		1
153	#N/A	2365811796P	IC,LINEAR(SMD) GM1117-2.5ST3 SOT-223 GAMA	I141 RB		1
154	#N/A	2365808596P	IC,LINEAR(SMD) CM1117KCM-2.5V SOT223 CHAMPION	I141 RC		1
155	#N/A	2419301400P	RECEIV BLOCK ECM-A38-3VS28 ECEL	I721		1
156	#N/A	2438000001P	SOFTWARE HDCP KEY CODE	KC01		1

Item	ViewSonic P/N	Ref. P/N	Description	Location	Universal number#	Q'ty
157	#N/A	2379330006P	BEAD,HI-IMPEDA Z= 30 ohm(200MHZ~) 0603 300mA	L100 L101L102 L130 L131 L132 L134L135		9
158	#N/A	2379322106P	BEAD,HI-IMPEDA Z= 220 ohm(200MHZ~) 0603 200mA	L103		1
159	#N/A	2379360106P	BEAD,HI-IMPEDA Z= 600 ohm(200MHZ~) 0603 200mA	L104 L136 L137 L138 L139 L148 L151 L153 L155 L159 L160 L171 L173		13
160	E-00003533	2379520196P	BEAD,HI-CURREN Z= 200 ohm 0805 I=2.0A	L105 L106 L107 L108 L110 L111 L112 L113 L114 L115 L116 L117 L118 L120 L121 L154 L156 L157 L161 L167 L168 L172 L183 L185 L189 L190 L191		27
161	#N/A	2371115001P	COIL,CHOKE 15uH/ 8*10 UEW 0.5mm/21.5Ts	L122 L123L124 L125		4
162	#N/A	2379500196P	BEAD,HI-CURREN Z= 80 ohm 0805 I=6.0A	L126 L127 L178 L182 L188		5
163	#N/A	2371120201P	COIL,CHOKE 2mH 10*15 0.3mm/231.5Ts P=5.0	L163 L164		2
164	E-R-0405-6600	2253200096P	RES CHIP 1/10W RC 0603 1/10W 0 ohm J T	L166 L206 R183 R193 R195 R200 R201 R202 R204 R205 R206 R305 R306 R318 R319 R326 R327 R378 R388 R410 R519 R520 R521 R523 R603 R624		26
165	#N/A	2377410996P	INDUCTOR CHIP N 1uH/0603 K T	L169		1
166	#N/A	2377410996P	INDUCTOR CHIP N 1uH/0603 K T	L170		1
167	#N/A	2404381106P	CONNECTOR 2DS-0341-001 DVI-D S.E	P100 RA		1
168	#N/A	2404381104P	CONNECTOR QH1121-FP0 DVI-D FOXCONN	P100 RB		1
169	#N/A	2407430900P	SOCKET DHSB-15FTF7 BLUE(661C) LEOCO	P101		1
170	M-MS-0808-6354	2404301105P	CONNECTOR JST PH 6P SIDE P=2.0 OR EQUAL	P102 P711		2
171	#N/A	2404301106P	CONNECTOR JST PH 7P SIDE P=2.0 OR EQUAL	P103 P701		2
172	#N/A	2407442900P	SOCKET MINI DIN 4P SIDE BLACK	P104		1
173	#N/A	2405322201P	RCA JACK 2*2P (4P BLU/YEL/RED/GRN)	P105		1
174	#N/A	2405324201P	RCA JACK 2*2P (WHITE/RED)	P106		1
175	#N/A	2404300003P	CONNECTOR JST XH 4P TOP P=2.5 OR EQUAL	P107 P115		2
176	#N/A	2405322202P	RCA JACK RCA JACK 2P (WHT/RED)	P110		1
177	#N/A	2405105900P	EARPHONE JACK ERR 3.5 SIDE 284C(BLUE)	P111		1
178	#N/A	2404322321P	CONNECTOR WRC-021V-07 21P*3.81mm KYOYAKU	P112 P113		2
179	#N/A	2405106000P	EARPHONE JACK 2SJ-P520-A04 (577C) SINGATRON	P114		1
180	#N/A	2404322130P	CONNECTOR 2R1L SIDE P=2.0mm 2046P30HT00	P116		1
181	#N/A	2404301011P	CONNECTOR JST XH 12P SIDE P=2.5 OR EQUAL	P118		1
182	#N/A	2407390144P	SOCKET,IC 1.27mm*44PIN PLCC SMD	P130		1
183	M-MS-0808-5483	2407310108P	SOCKET,IC 2.54mmX7.62 08PIN DIP D/L	P131		1
184	#N/A	2427407001P	WIRE HARNESS 7/7P H/H 1007#26+128C L=500mm	P702		1
185	#N/A	2427406001P	WIRE HARNESS 6/6P H/H 1007#26+128C L=420	P703		1
186	#N/A	2427404006P	WIRE HARNESS 4/2+2P H/A 1007#24 L=600mm	P704		1
187	#N/A	2427414002P	WIRE HARNESS 10/14P H/A 1007#24+128C L=400	P705		1
188	#N/A	2434420801P	AL SHIELDING TA W40*L80mm (AL)	P706		2
189	M-MS-0808-6571	2433303010P	SHIELDING FOAM W10*H10.5*L10mm	P707		2
190	#N/A	2433310011P	SHIELDING FOAM W10*H3*L15mm	P708		1
191	#N/A	2427430011P	WIRE HARNESS 30/30P 1571#28+168C L=250mm	P709		1
192	#N/A	2407001700P	SOCKET,ASSY INLET+CON/SW 1015#18 L=110	P801		1
193	A-PC-0106-0277	2427130097P	AC POWER CORD CHINA WALL 1.83M BLACK	P901		1
194	A-VC-0101-0386	2427501187P	I/O CABLE D15/D15 20276(3+6) 1.83M BLACK	P902		1
195	#N/A	2405313001P	RCA JACK RCA (R/W/Y)/SCART	P904		1
196	CB-00003425	2427701893P	CABLE RCA 3P(Y/R/W) 2562#26 1.8M BLK	P905		1
197	E-Q-0402-1377	2360300396P	XISTOR,NPN R SMMMBT3904 SOT-23 MOTOROLA	Q100 RA Q104 RA Q105 RA Q108 RA Q109 RA Q112 RA Q113 RA Q114 RA Q115 RA Q116 RA Q118 RA Q128 RA Q129 RA Q130 RA Q131 RA		15
198	E-Q-0402-1378	2360300596P	XISTOR,NPN R SMMMBT3904-7 SOT23 VISHAY	Q100 RB Q104 RB Q105 RB Q108 RB Q109 RB Q112 RB Q113 RB Q114 RB Q115 RB Q116 RB Q118 RB Q128 RB Q129 RB Q130 RB Q131 RB		15

Item	ViewSonic P/N	Ref. P/N	Description	Location	Universal number#	Q'ty
199	E-Q-0402-1087	2360301896P	XISTOR,NPN R SM MMBT3904LT1 SOT23 LRC	Q100 RC Q104 RC Q105 RC Q108 RC Q109 RC Q112 RC Q113 RC Q114 RC Q115 RC Q116 RC Q118 RC Q128 RC Q129 RC Q130 RC Q131 RC		15
200	E-Q-0402-1624	2360301696P	XISTOR,NPN R SMPMBS3904 SOT-23 PHILIPS	Q100 RD Q104 RD Q105 RD Q108 RD Q109 RD Q112 RD Q113 RD Q114 RD Q115 RD Q116 RD Q118 RD Q128 RD Q129 RD Q130 RD Q131 RD		15
201	E-Q-0402-1180	2360301296P	XISTOR,NPN R SM MMBT3904-F SOT23 DIODES	Q100 RE Q104 RE Q105 RE Q108 RE Q109 RE Q112 RE Q113 RE Q114 RE Q115 RE Q116 RE Q118 RE Q128 RE Q129 RE Q130 RE Q131 RE		15
202	E-Q-0402-1608	2360300896P	XISTOR,NPN R SM MMBT3904K SOT-23 FAIRCHILD	Q100 RF Q104 RF Q105 RF Q108 RF Q109 RF Q112 RF Q113 RF Q114 RF Q115 RF Q116 RF Q118 RF Q128 RF Q129 RF Q130 RF Q131 RF		15
203	#N/A	2360100696P	XISTOR,PNP R SM PMBS3906 SOT-23 PHILIPS	Q101 RA Q102 RA Q110 RA Q111 RA		4
204	E-Q-0402-1607	2360100796P	XISTOR,PNP R SM MMBT3906-F SOT-23 DIODES	Q101 RB Q102 RB Q110 RB Q111 RB		4
205	E-Q-0402-1607	2360100596P	XISTOR,PNP R SM MMBT3906-NL SOT23 FAIRCHILD	Q101 RC Q102 RC Q110 RC Q111 RC		4
206	E-Q-0402-1375	2360100396P	XISTOR,PNP R SM MMBT3906-7 SOT23 VISHAY	Q101 RD Q102 RD Q110 RD Q111 RD		4
207	E-R-0405-6416	2253233296P	RES CHIP 1/10W RC 0603 1/10W 3.3Kohm J T	R100 R101 R104 R105		4
208	E-R-0405-6419	2253247296P	RES CHIP 1/10W RC 0603 1/10W 4.7Kohm J T	R102 R296 R304 R307 R308 R309 R310 R321 R322 R323 R380 R397 R524 R525 R539 R619 R620 R621 R623		19

Item	ViewSonic P/N	Ref. P/N	Description	Location	Universal number#	Q'ty
209	E-R-0405-6409	2253210196P	RES CHIP 1/10W RC 0603 1/10W 100 ohm J T	R103 R106 R107 R109 R131 R132 R144 R168 R169 R170 R171 R348 R518		13
210	E-R-0405-6998	2253210096P	RES CHIP 1/10W RC 0603 1/10W 10 ohm J T	R108 R110 R114 R115 R121 R122 R126 R127		8
211	E-R-0405-6417	2253247096P	RES CHIP 1/10W RC 0603 1/10W 47 ohm J T	R111 R112 R113 R116 R117 R119 R164 R165 R166 R167 R186 R188 R190R191 R219 R220 R300 R337 R339 R341 R349 R350 R351		23
212	E-R-0405-6410	2253210296P	RES CHIP 1/10W RC 0603 1/10W 1.0Kohm J T	R118 R137 R141 R172 R173 R231 R232 R382 R384 R386 R387 R398 R401 R498 R499 R500 R501 R504 R505 R543 R548 R549 R551 R555 R556 R607 R616		27
213	E-R-0405-7003	2253275096P	RES CHIP 1/10W RC 0603 1/10W 75 ohm J T	R123 R124 R125 R197 R198 R199 R207 R208 R209 R329 R336 R338 R340 R376 R379 R389 R400 R546 R554		19
214	E-R-0405-6604	2253222296P	RES CHIP 1/10W RC 0603 1/10W 2.2Kohm J T	R129 R130 R622		3
215	#N/A	2253211296P	RES CHIP 1/10W RC 0603 1/10W 1.1Kohm J T	R139		1
216	E-R-0405-6601	2253210596P	RES CHIP 1/10W RC 0603 1/10W 1.0Mohm J T	R142 R297		2
217	#N/A	2253239196P	RES CHIP 1/10W RC 0603 1/10W 390 ohm J T	R143 R196		2
218	E-R-0405-6602	2253215196P	RES CHIP 1/10W RC 0603 1/10W 150 ohm J T	R155		1
219	E-R-0405-7001	2253233096P	RES CHIP 1/10W RC 0603 1/10W 33 ohm J T	R156 R157 R518 R159 R160 R161 R162 R163 R184 R185 R408 R409 R527 R528		14
220	#N/A	2253227096P	RES CHIP 1/10W RC 0603 1/10W 27 ohm J T	R192 R215 R217 R228 R230		5
221	E-R-0405-7002	2253251196P	RES CHIP 1/10W RC 0603 1/10W 510 ohm J T	R212		1
222	E-R-0405-6412	2253220196P	RES CHIP 1/10W RC 0603 1/10W 200 ohm J T	R221 R222 R223		3
223	#N/A	2253282096P	RES CHIP 1/10W RC 0603 1/10W 82 ohm J T	R226		1
224	E-R-0405-6418	2253247196P	RES CHIP 1/10W RC 0603 1/10W 470 ohm J T	R227 R301 R302 R515		4
225	#N/A	2253256096P	RES CHIP 1/10W RC 0603 1/10W 56 ohm J T	R229 R239		2
226	E-R-0405-6415	2253230296P	RES CHIP 1/10W RC 0603 1/10W 3.0Kohm J T	R233 R234 R235 R413		4
227	E-R-0405-7000	2253222196P	RES CHIP 1/10W RC 0603 1/10W 220 ohm J T	R320 R490		2
228	#N/A	2253213296P	RES CHIP 1/10W RC 0603 1/10W 1.3Kohm J T	R381 R399		2
229	#N/A	2253212396P	RES CHIP 1/10W RC 0603 1/10W 12Kohm J T	R502 R503 R514 R532		4
230	E-R-0405-6999	2253220396P	RES CHIP 1/10W RC 0603 1/10W 20Kohm J T	R506 R507 R508 R509 R510 R511 R512 R513 R599		9
231	E-R-0405-6606	2253233196P	RES CHIP 1/10W RC 0603 1/10W 330 ohm J T	R516		1
232	#N/A	2253239296P	RES CHIP 1/10W RC 0603 1/10W 3.9Kohm J T	R517		1
233	#N/A	2253239396P	RES CHIP 1/10W RC 0603 1/10W 39Kohm J T	R535		1
234	#N/A	2253212496P	RES CHIP 1/10W RC 0603 1/10W 120Kohm J T	R538		1
235	#N/A	2253224396P	RES CHIP 1/10W RC 0603 1/10W 24Kohm J T	R608		1
236	E-00003527	2253247396P	RES CHIP 1/10W RC 0603 1/10W 47Kohm J T	R617		1
237	E-R-0405-6006	2259233008P	RES.CHIP NETWOI8P4R 1/16W 33 ohm J P=0.8	RP01 RP02 RP03		3
238	E-R-0405-6422	2259247008P	RES.CHIP NETWOI8P4R 1/16W 47 ohm J P=0.8	RP04 RP05 RP06 RP07 RP08 RP09 RP10 RP11 RP20 RP21		10
239	E-R-0405-6608	2259210108P	RES.CHIP NETWOI8P4R 1/16W 100 ohm J P=0.8	RP12 RP13		2
240	E-R-0405-6411	2253210396P	RES CHIP 1/10W RC 0603 1/10W 10Kohm J T	RR120 R128 R182 R225 R236 R237 R298 R303 R311 R312 R313 R314 R315 R316 R317 R383 R385 R391 R533 R537 R541		21
241	M-SW-0815-0182	2403702200P	TACT SWITCH TSAA-2 HUAJIE	S702 S703 S704 S705 S706 S707 S721		7
242	#N/A	2202520400P	PCB MULTILAYERJC328A11E M/B FR4*4 340*240	U101		1
243	#N/A	2202129800P	PC BOARD JC278 KEY/B CEM1 120*20 V1.00	U701		1
244	#N/A	2202129901P	PC BOARD JC278 IR/B CEM1 54*53 V2.01	U702		1
245	#N/A	2200202300P	PC BOARD ASS'Y FSP212-3F01 JC328 SPI	U801 RA		1
246	#N/A	2200202400P	PC BOARD ASS'Y 201-C001 JC328 DARFON	U801 RB		1
247	#N/A	2200202500P	PC BOARD ASS'Y OPV-007 LIEN CHANG	U801 RC		1
248	E-00003571	2212008100P	LCD PANEL T315XW01 V2 AUO	V901		1
249	#N/A	2391310062P	SPEAKER ASS'Y 10W/6ohm L228*W65*H77mm	W901		2
250	E-X-0415-0111	2369102901P	XTAL.OSC 14.31818MHZ/49US 0.1mW/30PF	X100		1
251	E-X-0415-0112	2369103901P	XTAL.OSC 24.576MHZ/49US 0.1mW/20pF	X101		1
252	#N/A	2369105701P	XTAL.OSC 24.000MHZ/49US 0.1mw/16PF	X103		1
253	#N/A	2369105501P	XTAL.OSC 18.432MHZ/49US 0.1mW/12pf	X105		1

9. Block Diagram

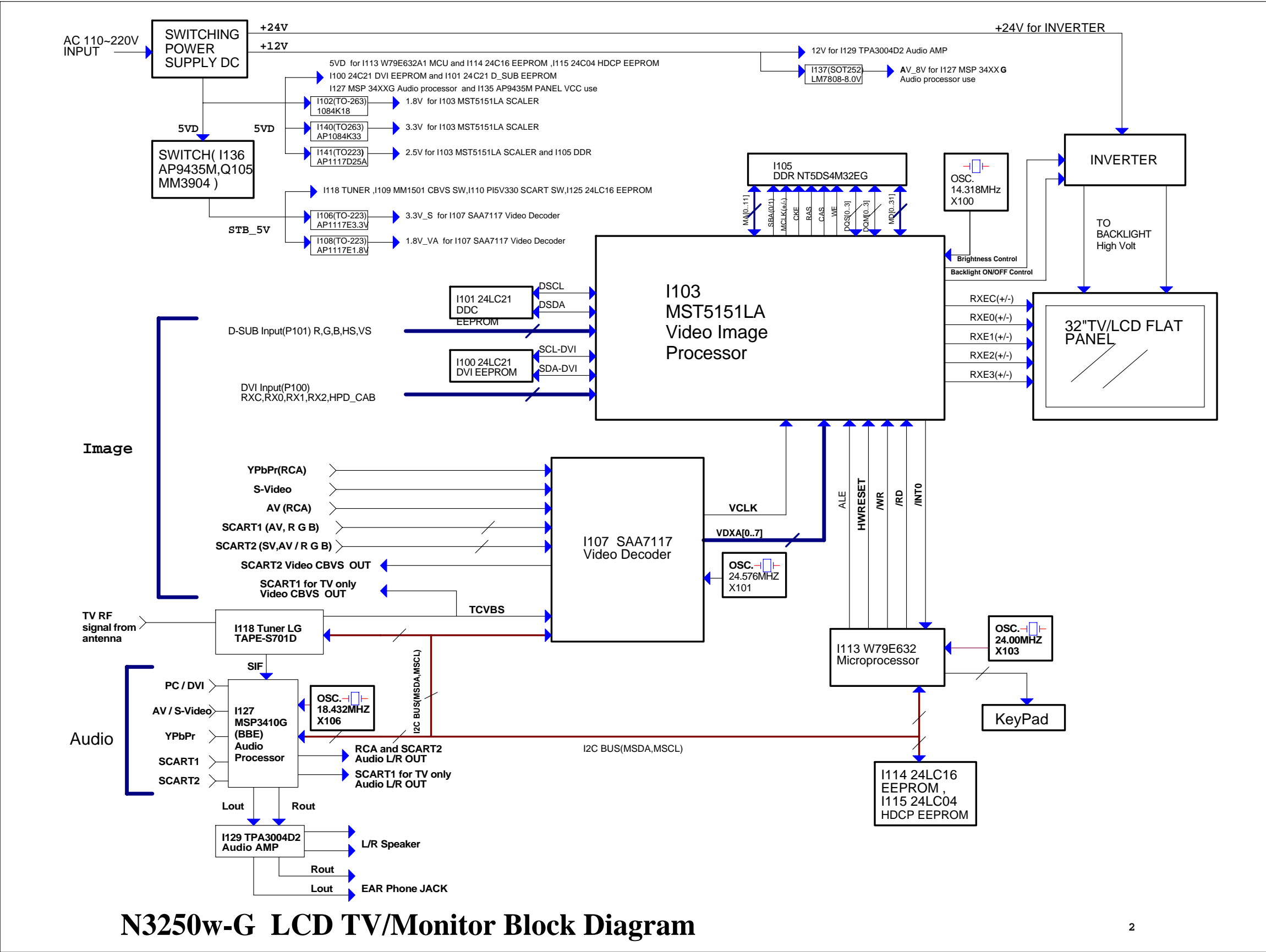

N3250w-G LCD TV/Monitor Block Diagram

10. Schematic Diagrams

10.1. D-SUB / DVI

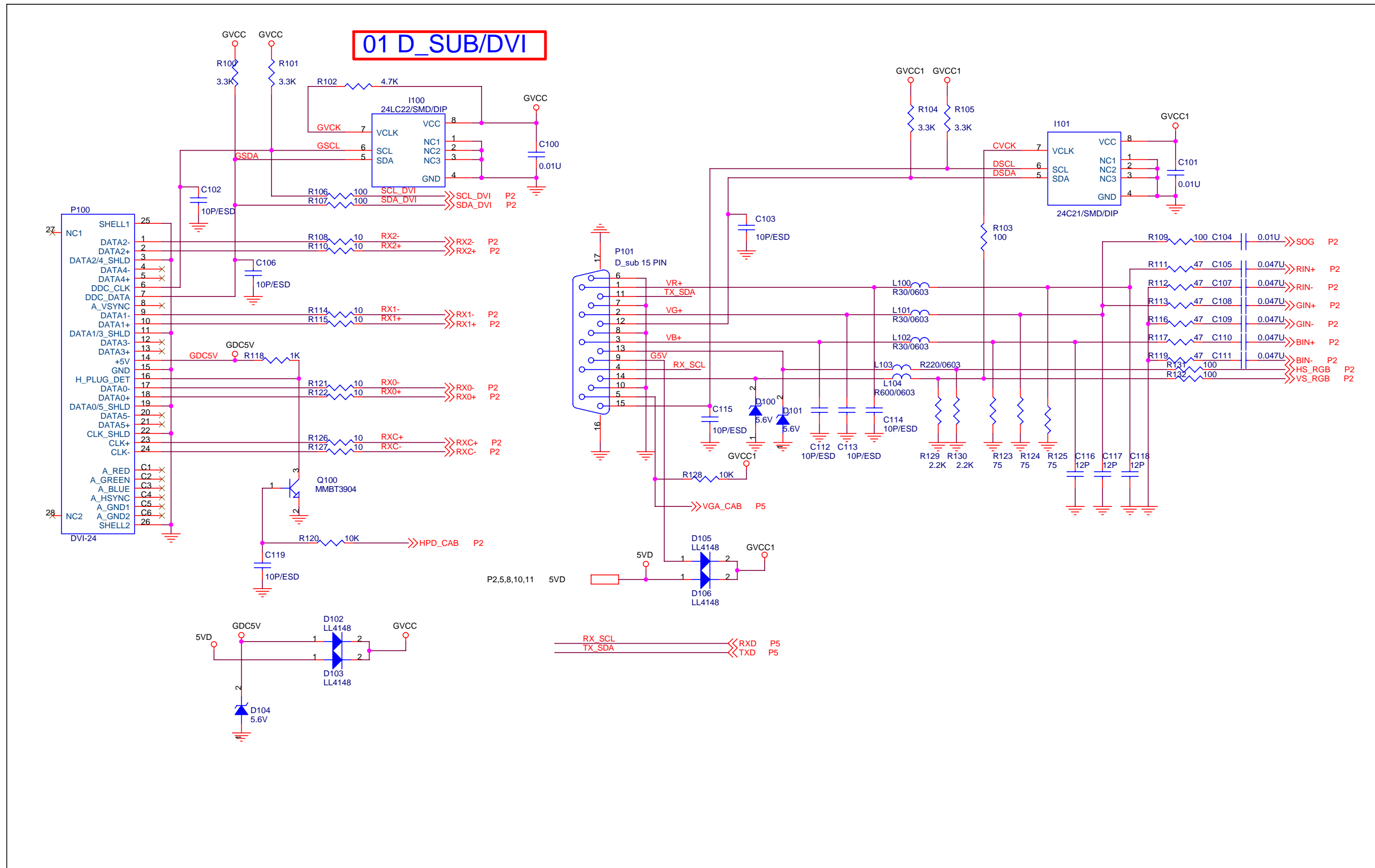

10.2. SCALER MST5151LA

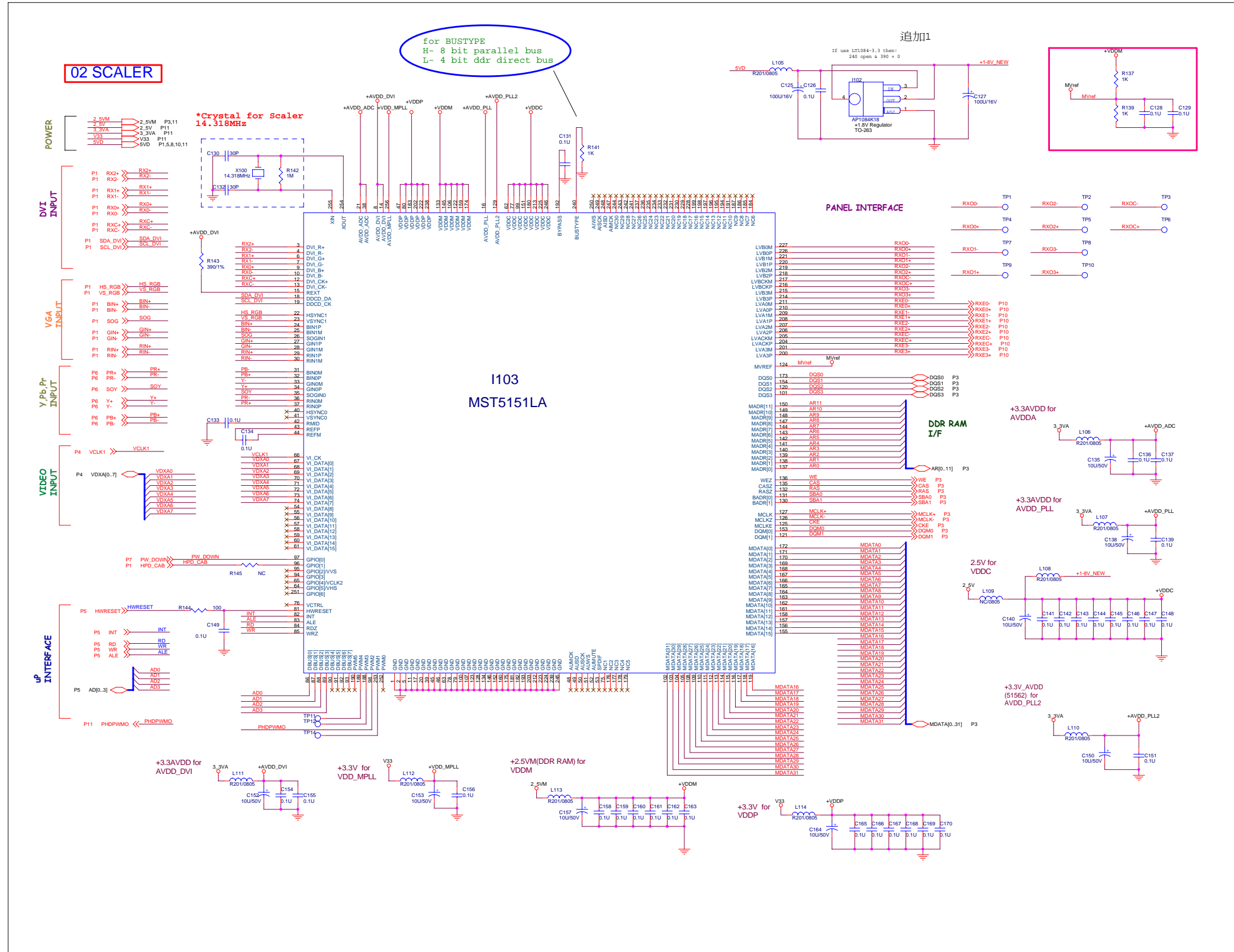

10.3. DDR NT5DS4M32E

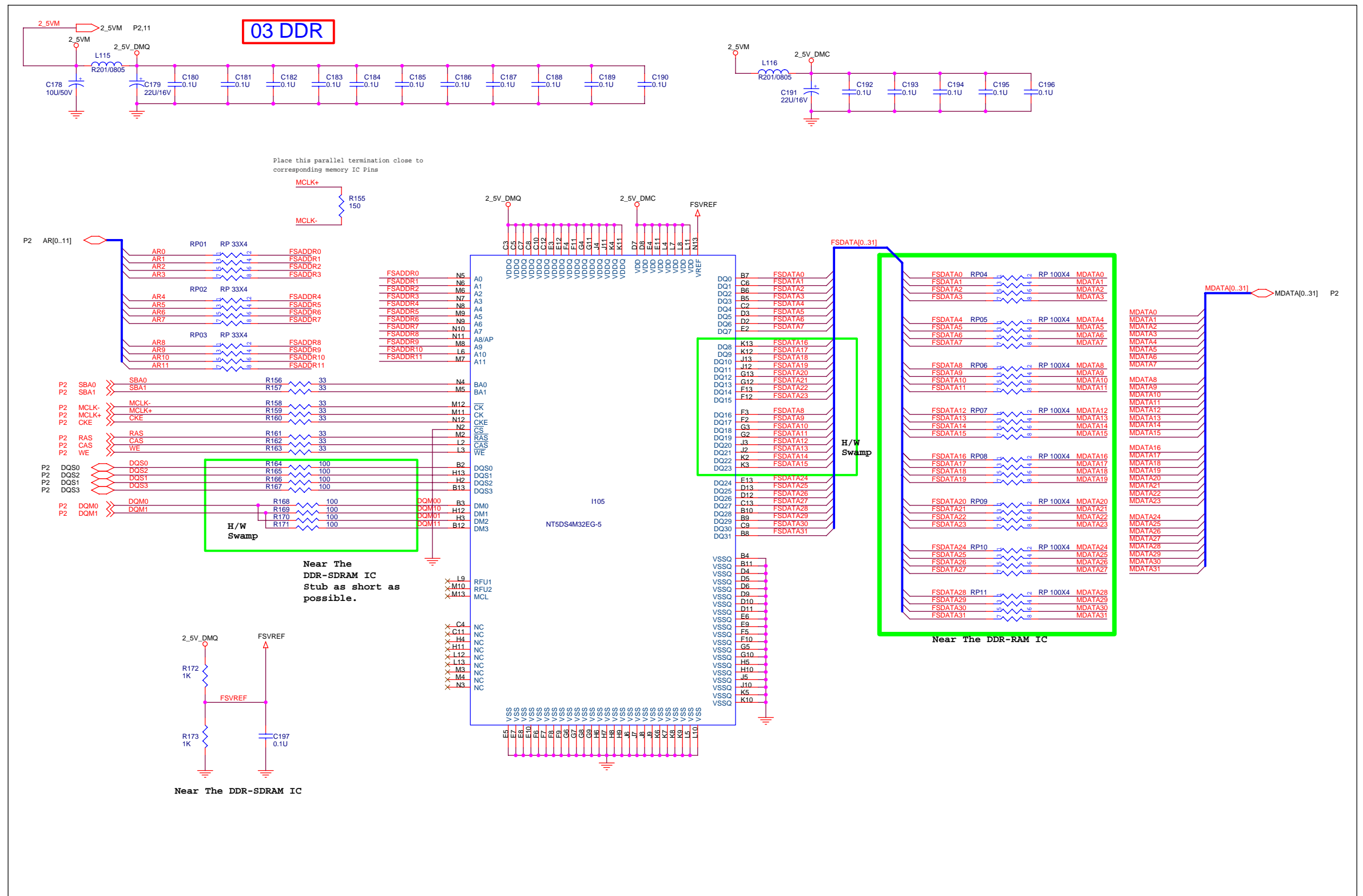

10.4. VIDEO DECODER SAA7117

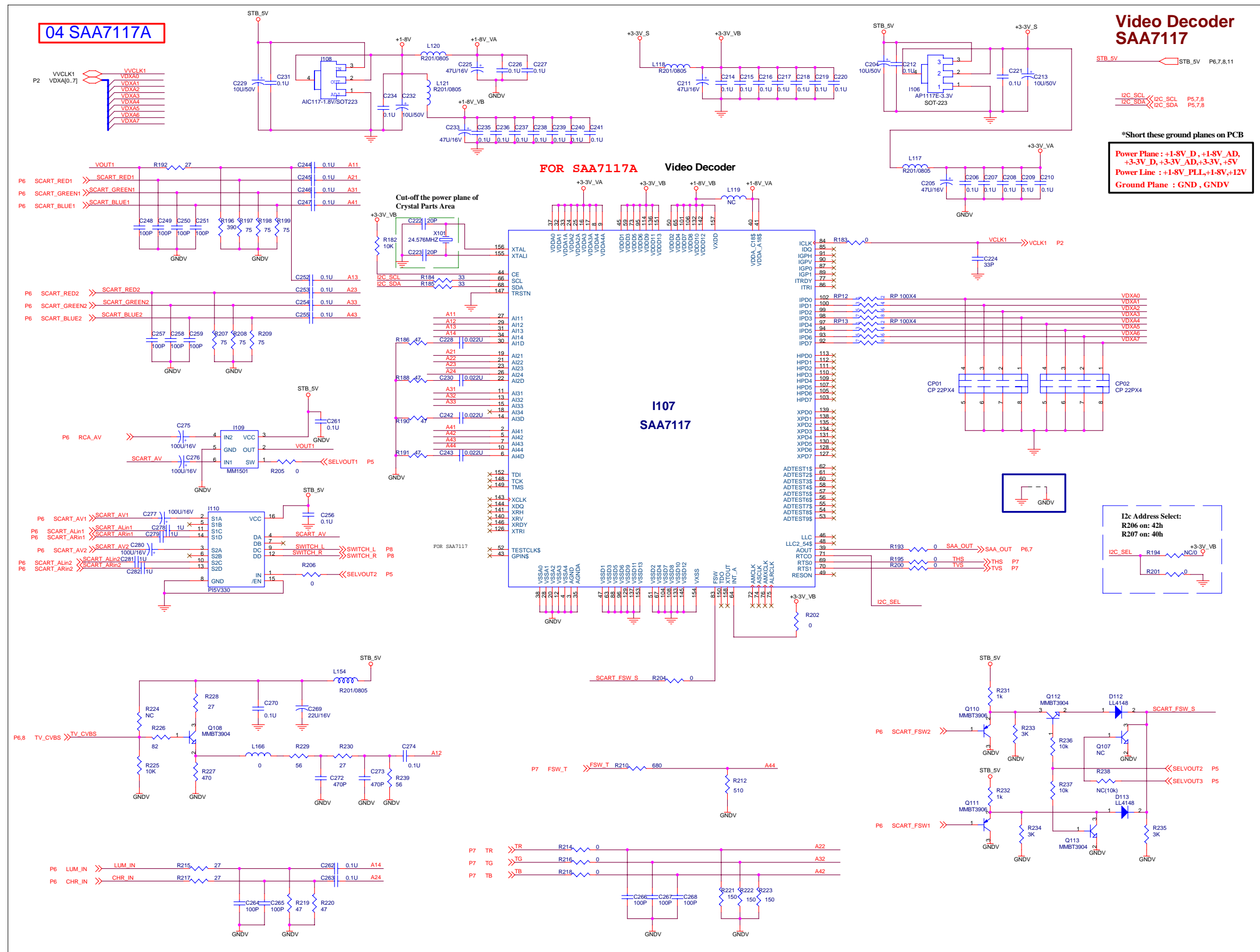

10.5. MCU W79E632

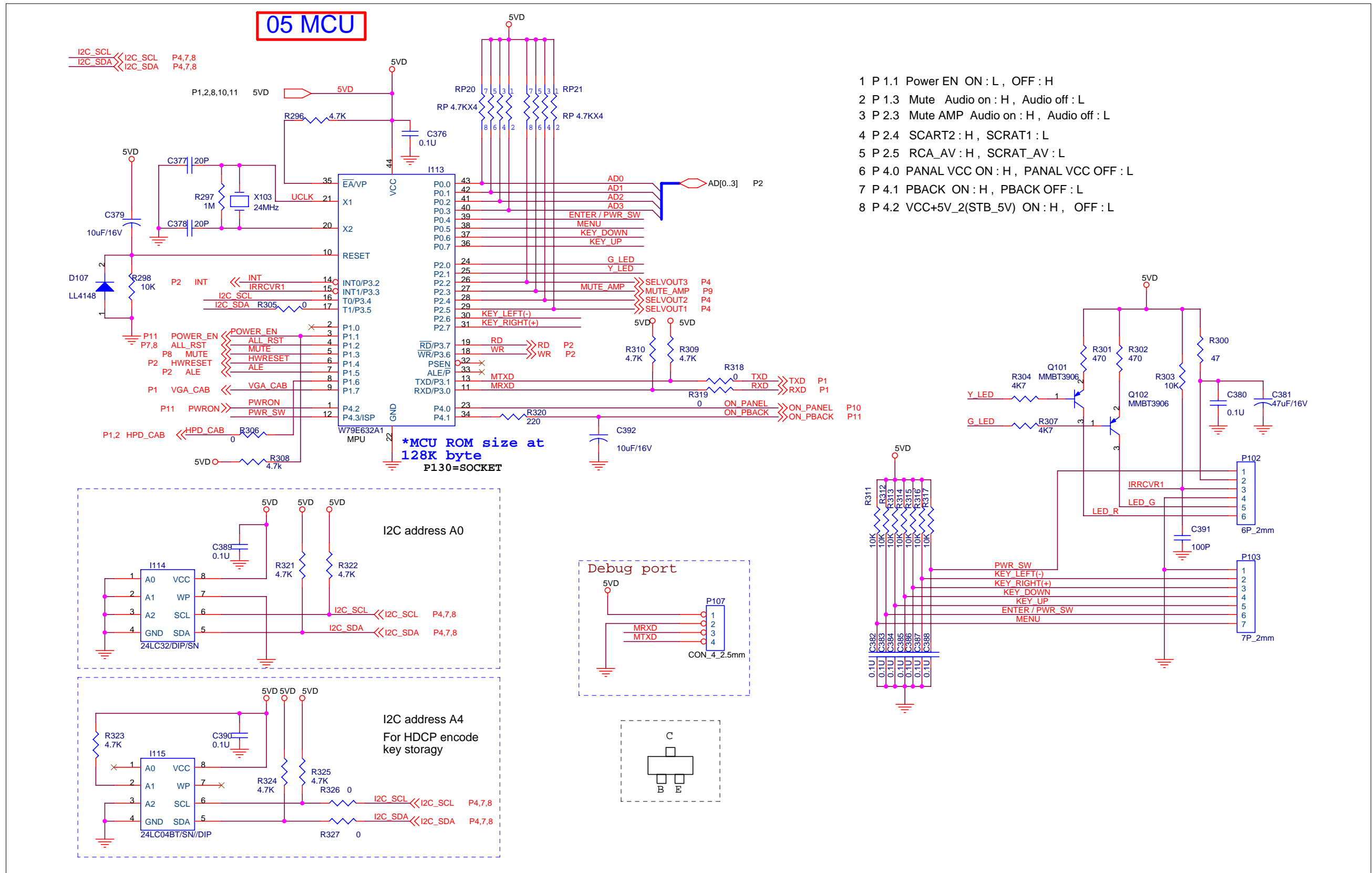

10.6. SCART RCA VIDEO AUDIO JACK

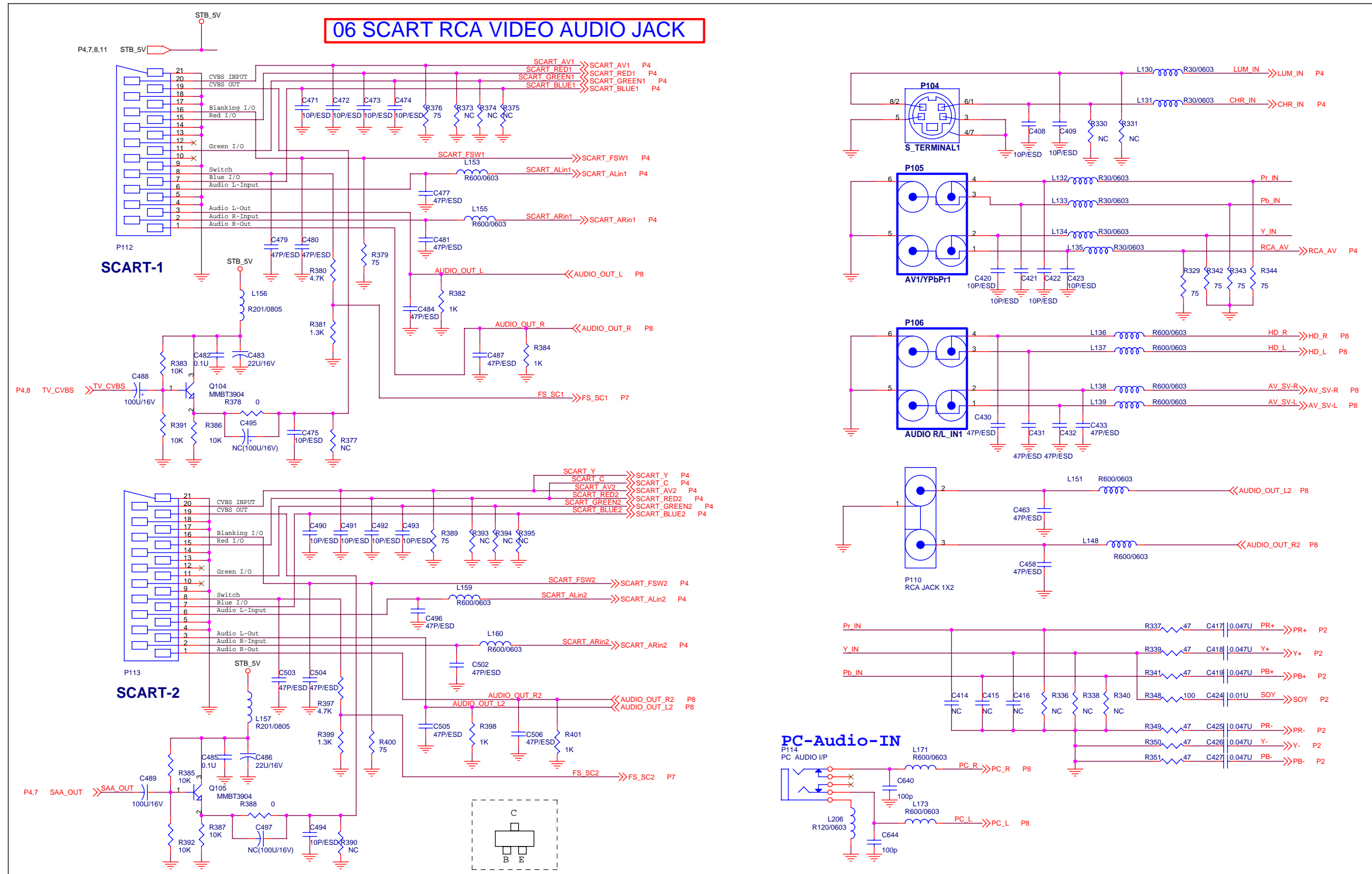

10.7. AUDIO DECODE AND TUNER

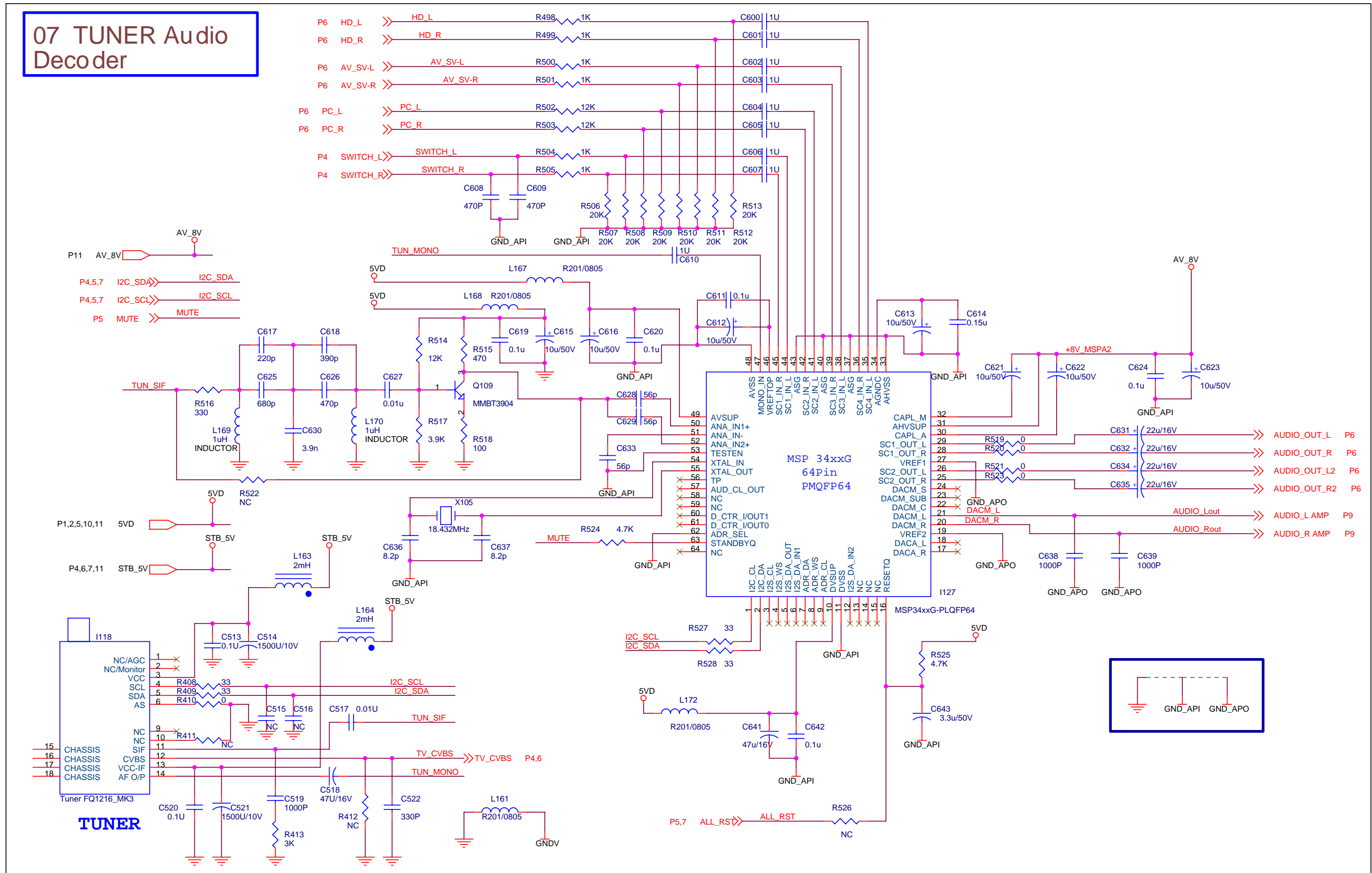

10.8. AUDIO AMP TPA3004D2

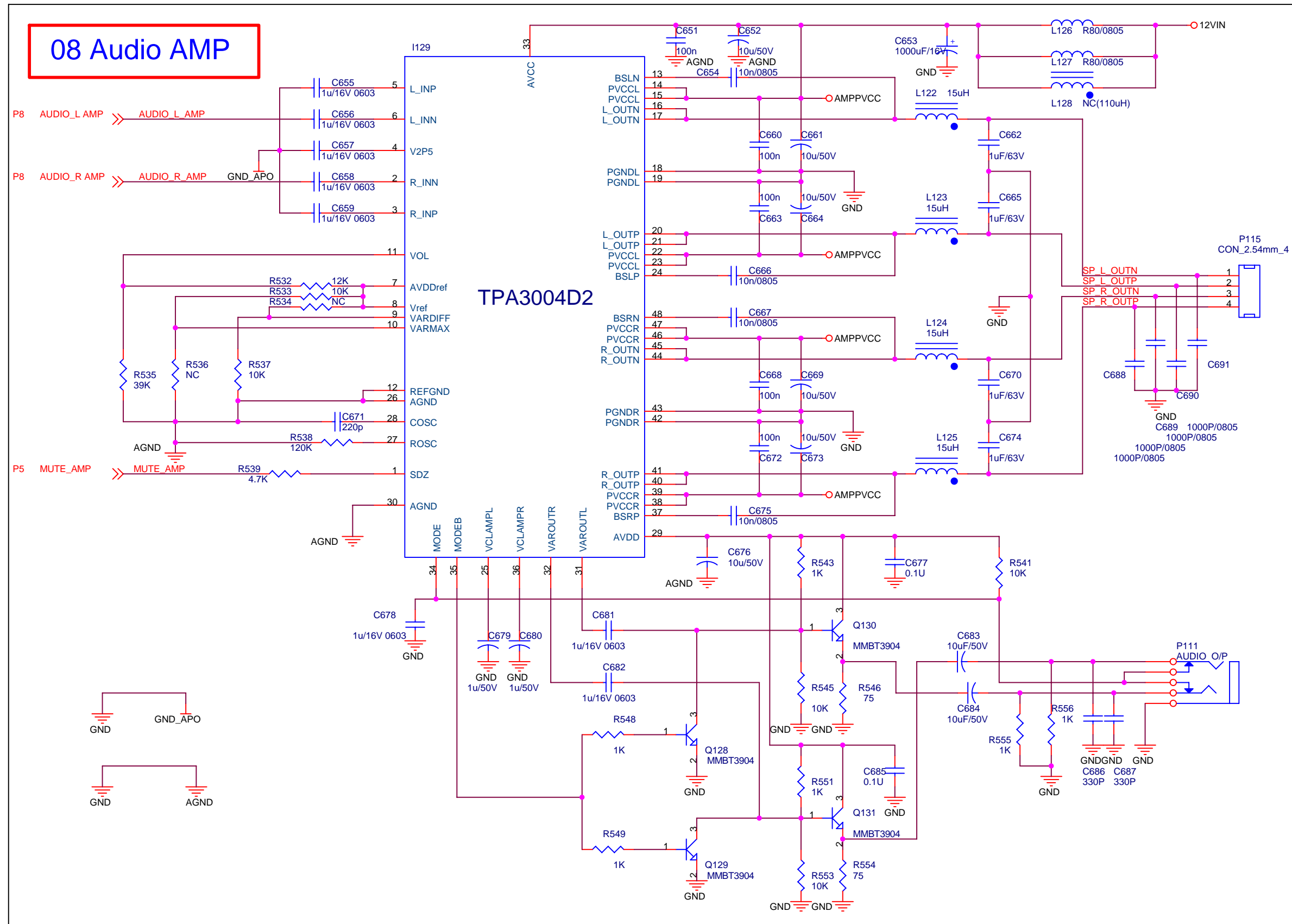

10.9. LVDS OUT

09 LVDS OUT

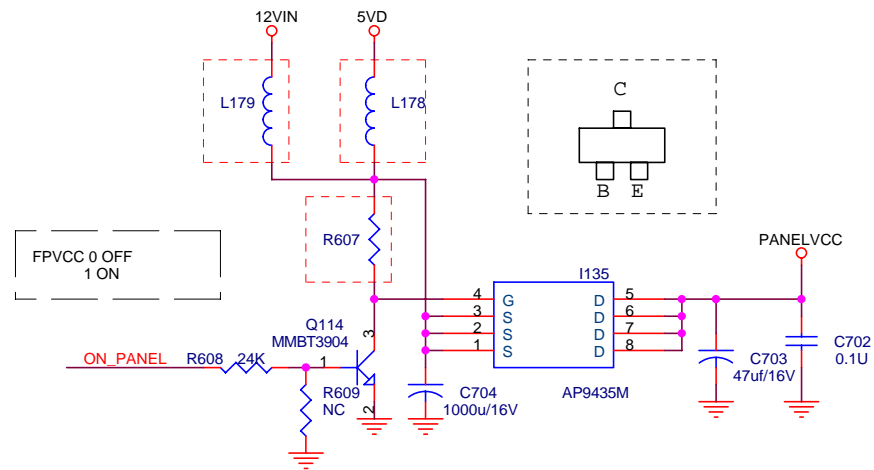
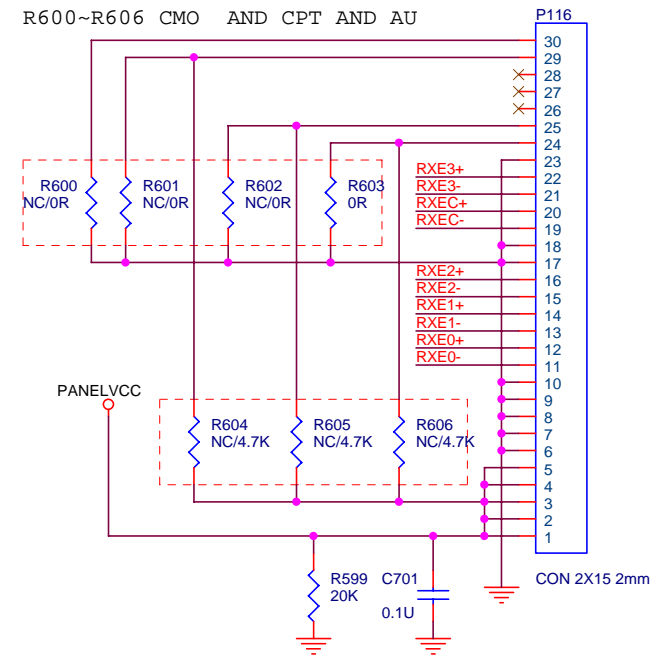
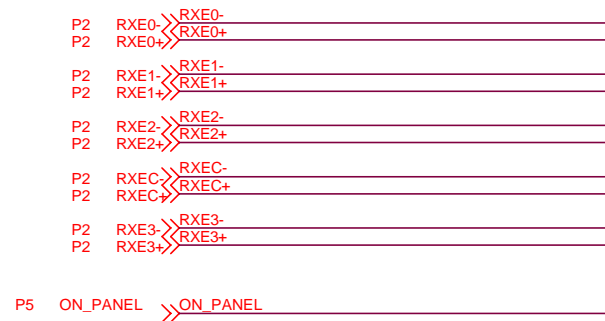

	CPT	CMO	AU
L178	NC	R80/0805/BEAD	R80/0805/BEAD
L179	R80/0805/BEAD	NC	NC
R600	NC	NC	NC
R601	0R	NC	NC
R602	NC	NC	NC
R603	0R	0R	0R
R604	NC	NC	NC
R605	NC	NC	NC
R606	NC	NC	NC
R607	2.2K	1K	1K

10.10. POWER DC DC

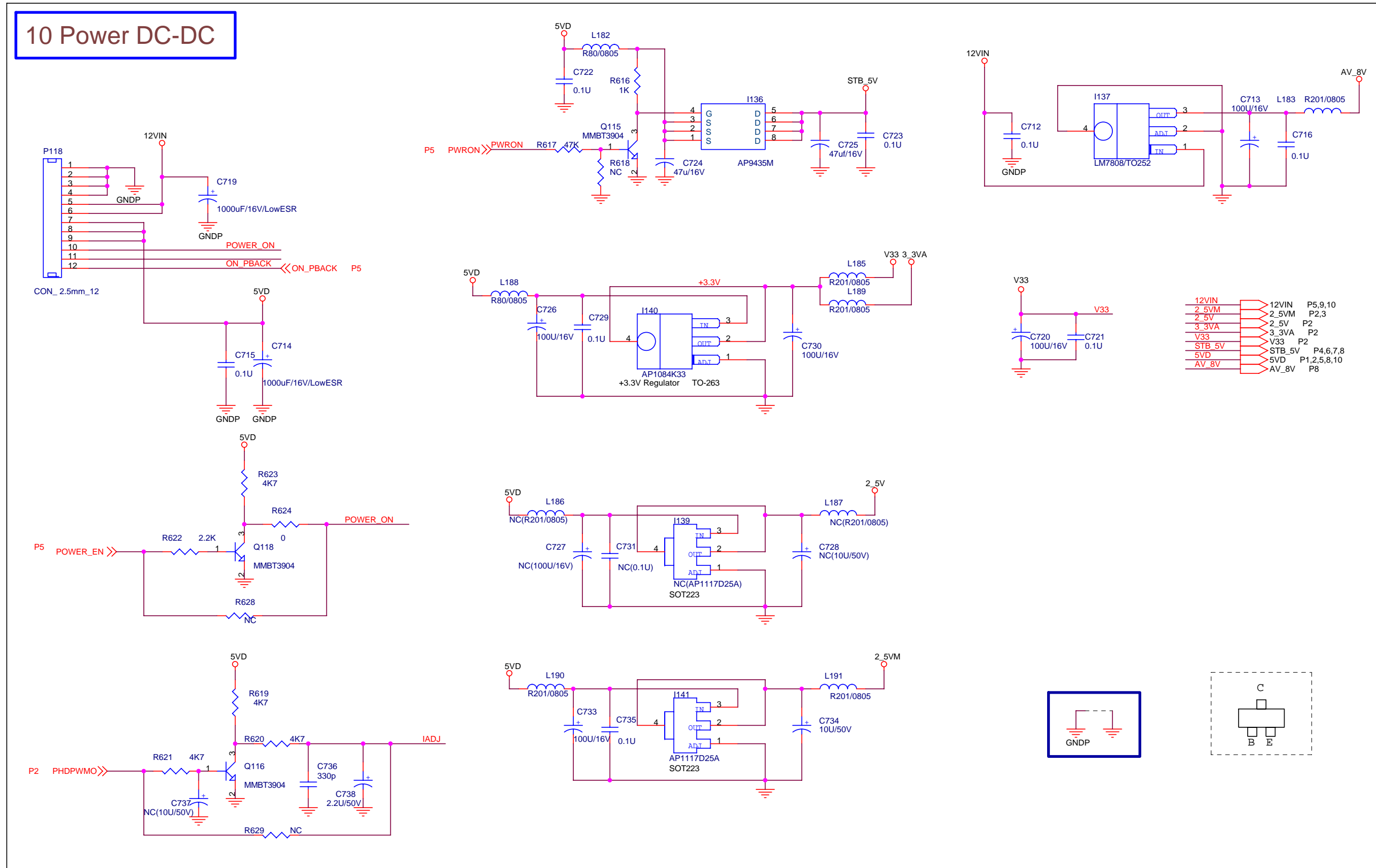

10.11. KEYPAD IR

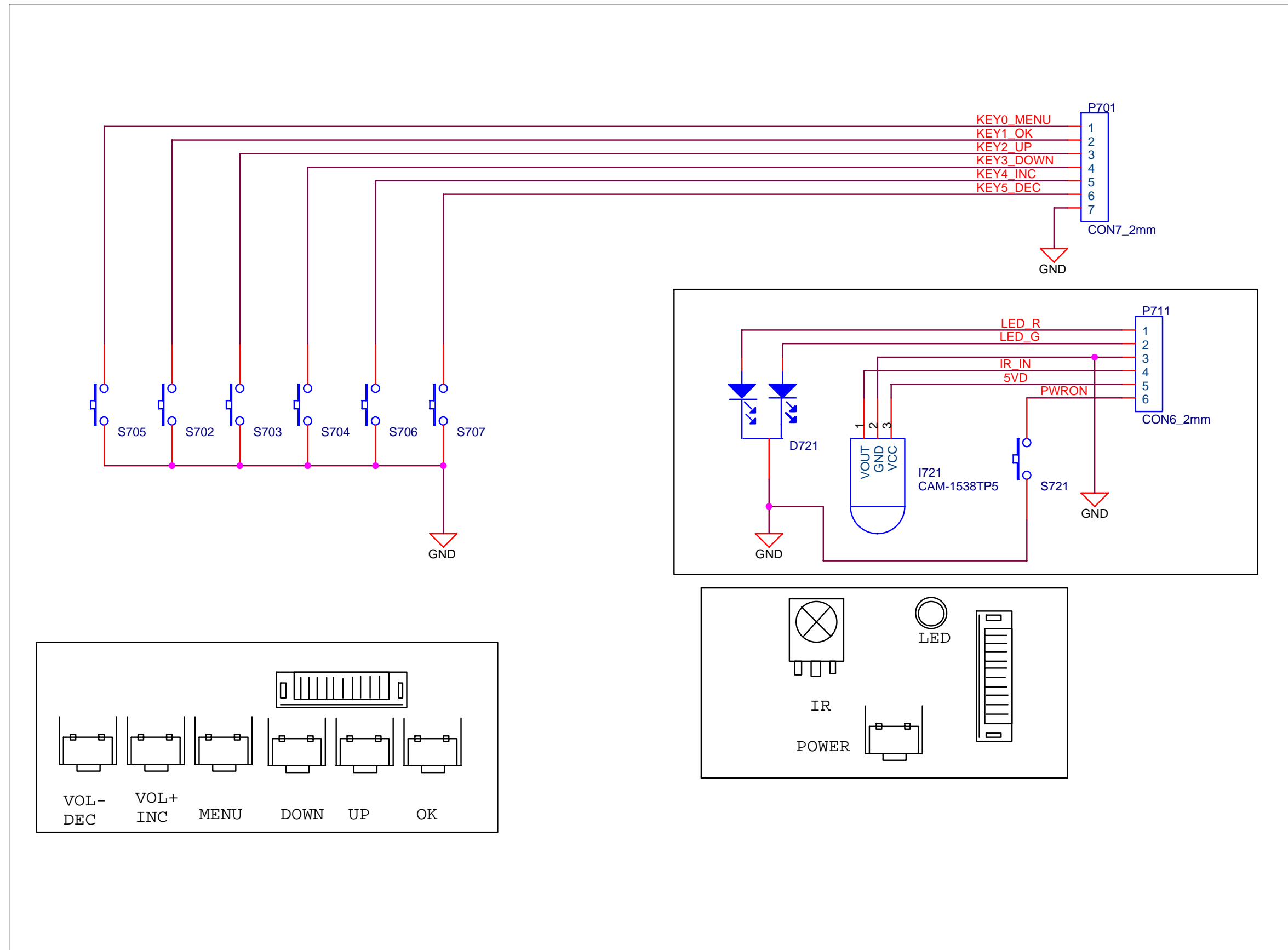

11. Working Theorem

A. A/D converter (PC & YPbPr) and DVI(HDCP) input

The MST5151LA offers designers the flexibility of an analog interface and High-Definition Multimedia Interface (DVI) receiver integrated on a single chip. Also included is support for High bandwidth Digital Content Protection (HDCP).

Analog Interface

The MST5151LA is a complete 8-bit 165 MSPS monolithic analog interface optimized for capturing Component Video (YPbPr) and RGB graphics signals. Its 165 MSPS encode rate capability and full power analog bandwidth of 300 MHz supports all HDTV formats (up to 1080p) and FPD resolutions up to UXGA (1600 x 1200 @ 60 Hz). The analog interface includes a 165 MHz triple ADC with internal 3.3V reference, a Phase Locked Loop (PLL), and programmable gain, offset, and clamp control. The user provides only 1.8V and 3.3V power supply, analog input, and Hsync. Three-state CMOS outputs may be powered from 1.8V to 3.3V. The MST5151LA on-chip PLL generates a pixel clock from Hsync. Pixel clock output frequencies range from 12MHz to 165 MHz. PLL clock jitter is typically less than 500 ps p-p at 165 MHz. The MST5151LA also offers full sync processing for composite sync and Sync-on-Green (SOG) applications.

Digital Interface

The MST5151LA contains a DVI(HDCP) 1.0 compatible receiver and supports all HDTV formats (up to 1080p) and display resolutions up to UXGA (1600 x 1200 @ 60 Hz). The receiver features an intra-pair skew tolerance of up to one full clock cycle. With the inclusion of HDCP, displays may now receive encrypted video content. The MST5151LA allows for authentication of a video receiver, decryption of encoded data at the receiver, and renew ability of that authentication during transmission as specified by the HDCP v1.1 protocol.

Fabricated in an advanced CMOS process, the MST5151LA is provided in a space-saving 100-lead LQFP surface-mount Pb free plastic package and is specified over the 0 °C to 70 °C temperature range.

B. Video Decoder (video)

The SAA7117 is a highly integrated NTSC, PAL, and SECAM video decoder support for high quality LCD-TV video applications, SAA7117 supports NTSC/PAL chroma and luma separation using a 2-dimensional adaptive comb filter for reducing the cross-luma and cross-chroma artifacts. The frame buffer is also use for 2D noise reduction circuit that resumes good visual quality when the input signal is a noisy video source

The SAA7117 10-bits CMOS Analog-to-Digital Converters(ADC) at four-fold "ITU656" oversampling(54MHZ);Sixteen analog input pins.allowing fo multiple combinations of composite,S-Video component video;Eight 3-level capable sensor pins for D-connector or SCART AV- and RGB- switch signals(three of those can be active simultaneously),one Fast blanking input;Level sensitive fast blanking(RGB switch control);I²C read back of digital AGC gain factor; The component, composite, or S-Video signals are sampled at a free-run external clock frequency (10~58.6 MHz). After the video decoder processing, the video data was sent out with a line-locked alignment rate (24.576 MHz).

The SAA7117 comes with 160-pin QFP package.

C. Scaling controller

The MST5151LA chip is a LCD-TV controller chip for color display up to SXGA or /WXGA wide screen panel. It includes a 128/256/512 4-bit/fixel font 3D interlace-to progressive video processing. It also supports non-linear scaling for 4:3 to/form 16:9 conversion, flexible picture in video display, cinema to TV conversion, hue/saturation adjustment, and advanced OSD system.

The MST5151LA chip is targeted for the applications of high-end LCD-TV. It will accept all HDTV video signals for flat panel display. It comes with 256-pin LQFP package.

General Feature:

- 1M*32Bit*4Banks SDRAM controller for interlaced to progressive video processing and fram-rate conversion for computer graphics.
- PIP (picture in picture)/POP(picture on picture)
- MstarACE-2 picture/color processing and Embedded On-screen display controller(OSD) engine
- Hardware mode detection for HDTV.
- Two sets of mode detection for flexible simultaneous main- picture and sub-picture display.
- Copy protection detect and display enable.
- On chip hue, saturation, brightness, contrast, and gamma correction.
- Max pixel rate up to 135 MHz.
- Video Black White Expansion.
- Flesh tone adjustment.
- Improved temporal-spatial dithering.
- Non-linear scaling for 4:3 to/form 16:9 conversion.
- Auto cinema mode detection, 3:2/2:2 pull-down, and 3D de-interlacing.
- Desk and ceiling mode for projector application.
- PWM (Pulse Width Modulators) from 28K to 100Hz.

D. Audio

Three audio sources put into MSP 3410G which fist select the sources and do pre-amplify. The bass treble control also is provided. The control of all the functions is accomplished by serial bus. Audio amplifier put into IC TI TPA3004D2 is a class-D amplifier that is output power of 20W/channel on a 12V power supply operation.

E. Tuner

The Antenna receive the TV signal and modulate it to the CVBS signal which can be recognized by the decoder and FM-stereo/FM-mono/NICAM audio signal output to the sound Automatic standard decoder IC MSP3410G. The MCU can automatic detect the tuner and send order by serial bus.

12. Wiring Diagram

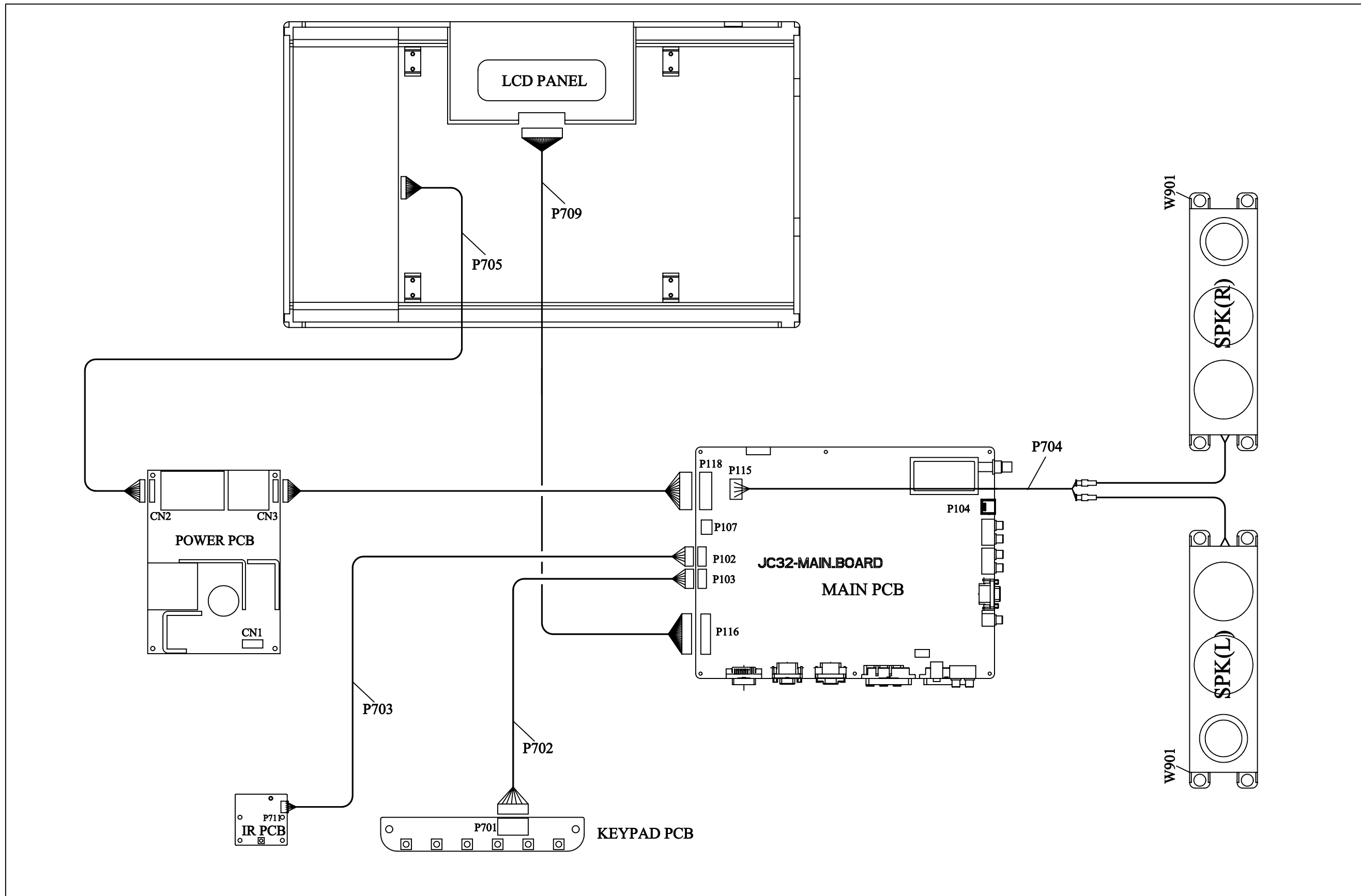

13. PCB Layout Diagrams

13.1. MAIN PCB TOP VIEW

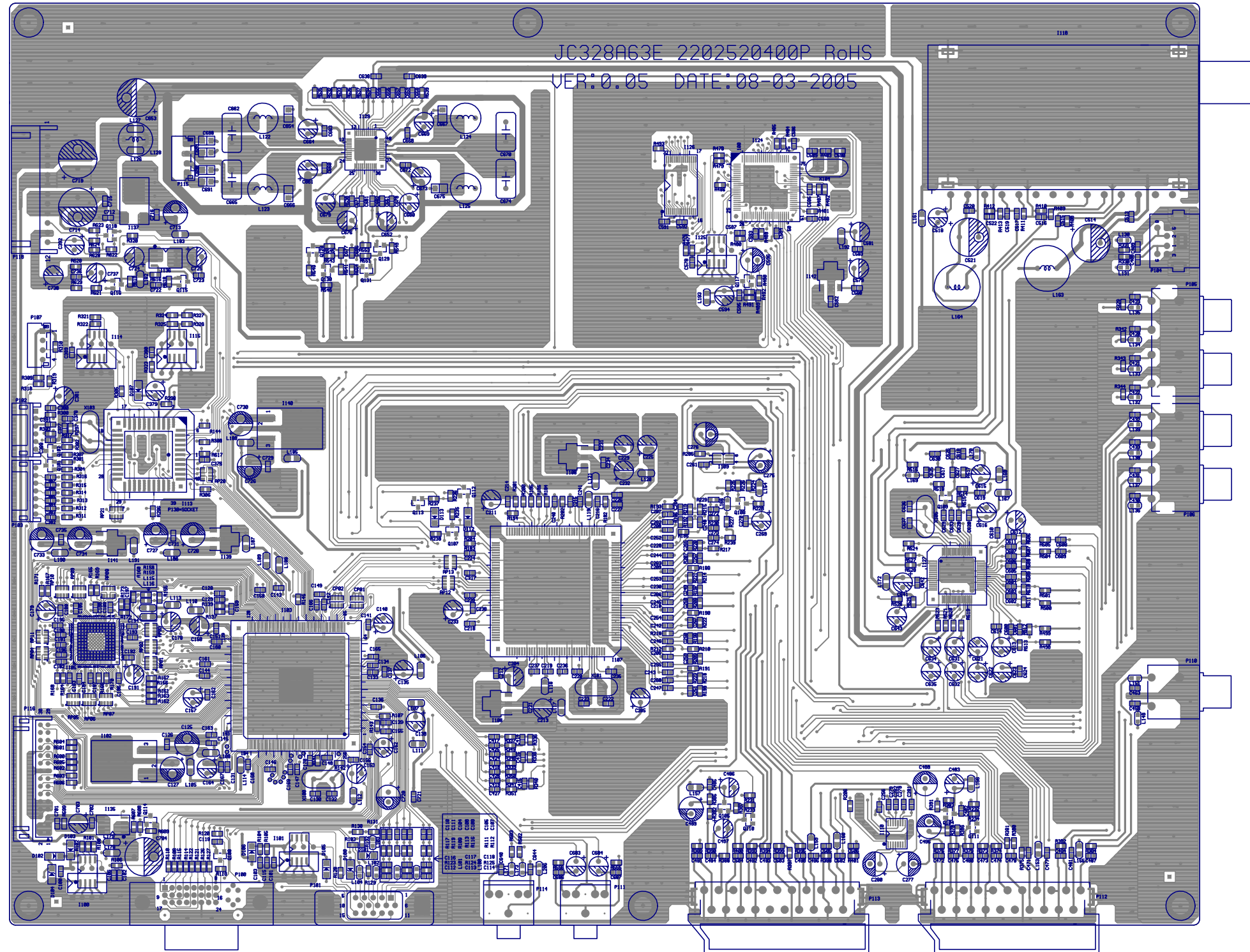

13.2. MAIN PCB BOTTOM VIEW

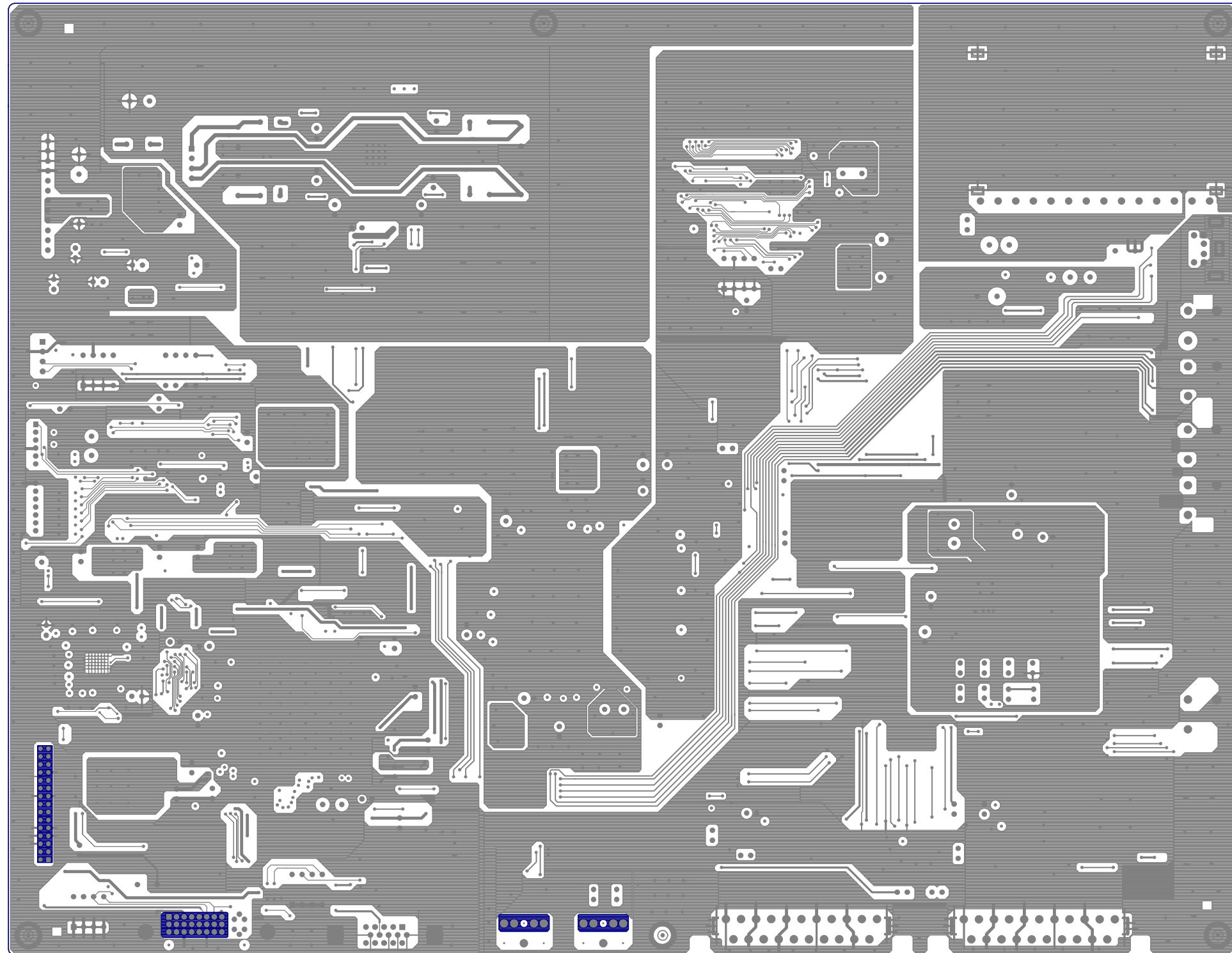

13.3. KEYPAD PCB TOP VIEW

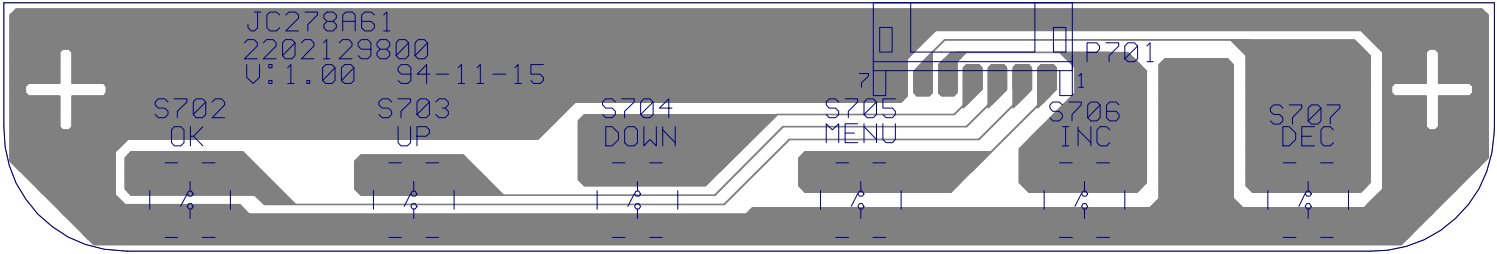

13.4. KEYPAD PCB BOTTOM VIEW

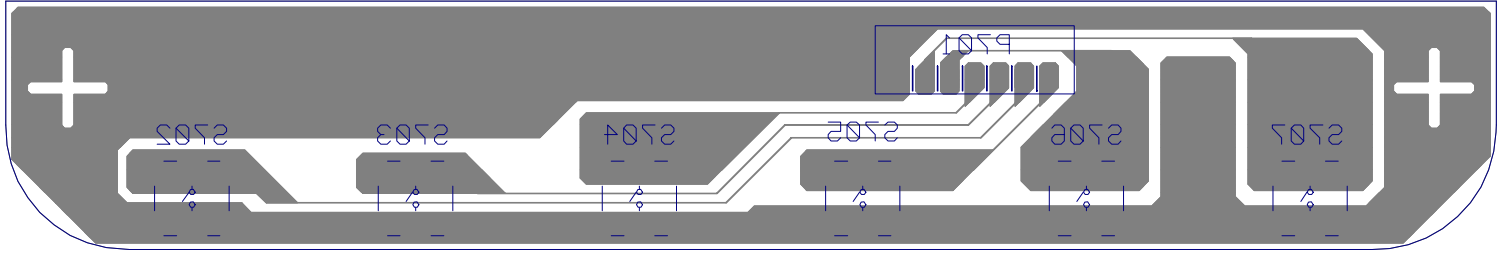

13.5. IR PCB TOP VIEW

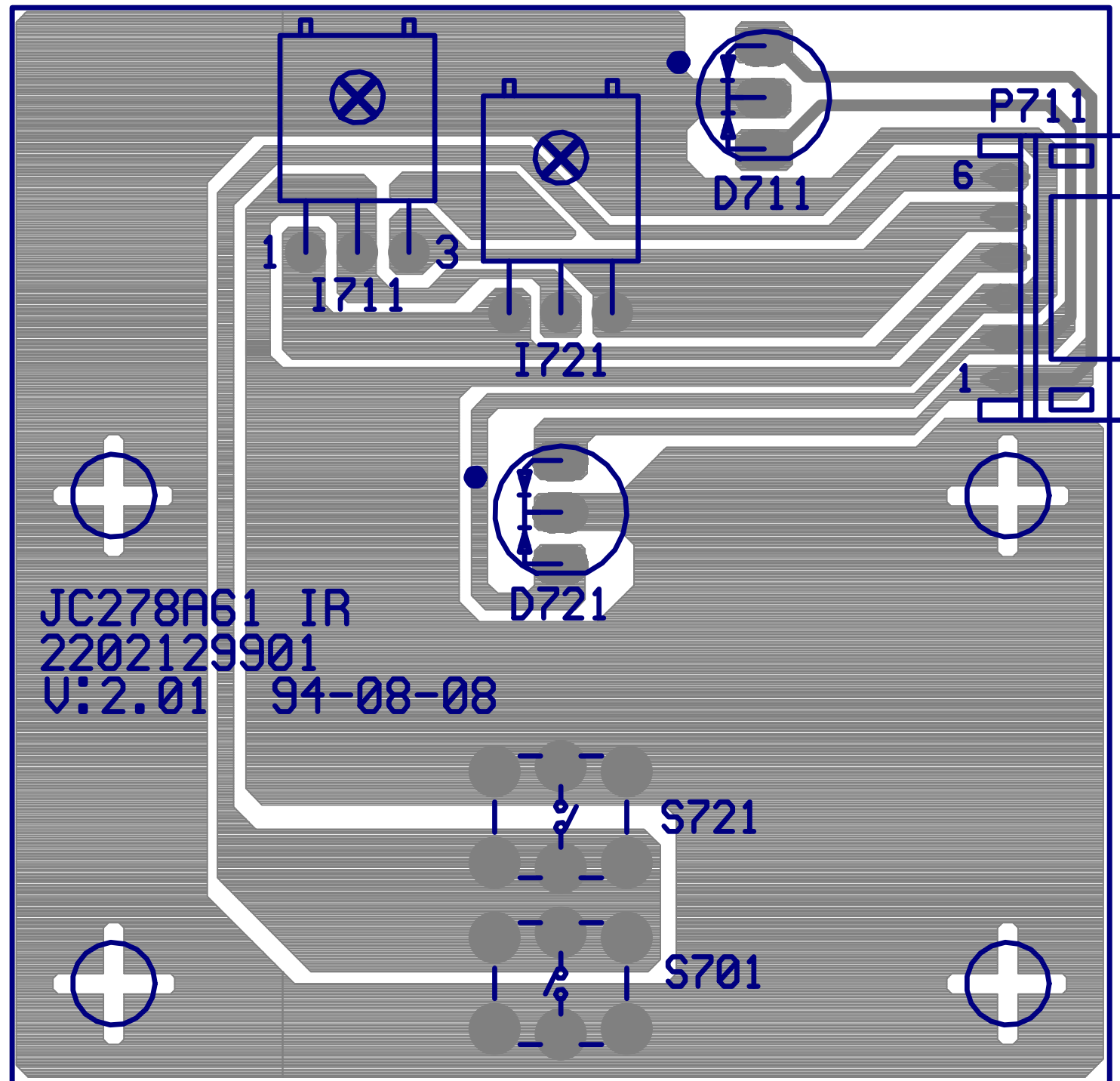

13.6. IR PCB BOTTOM VIEW

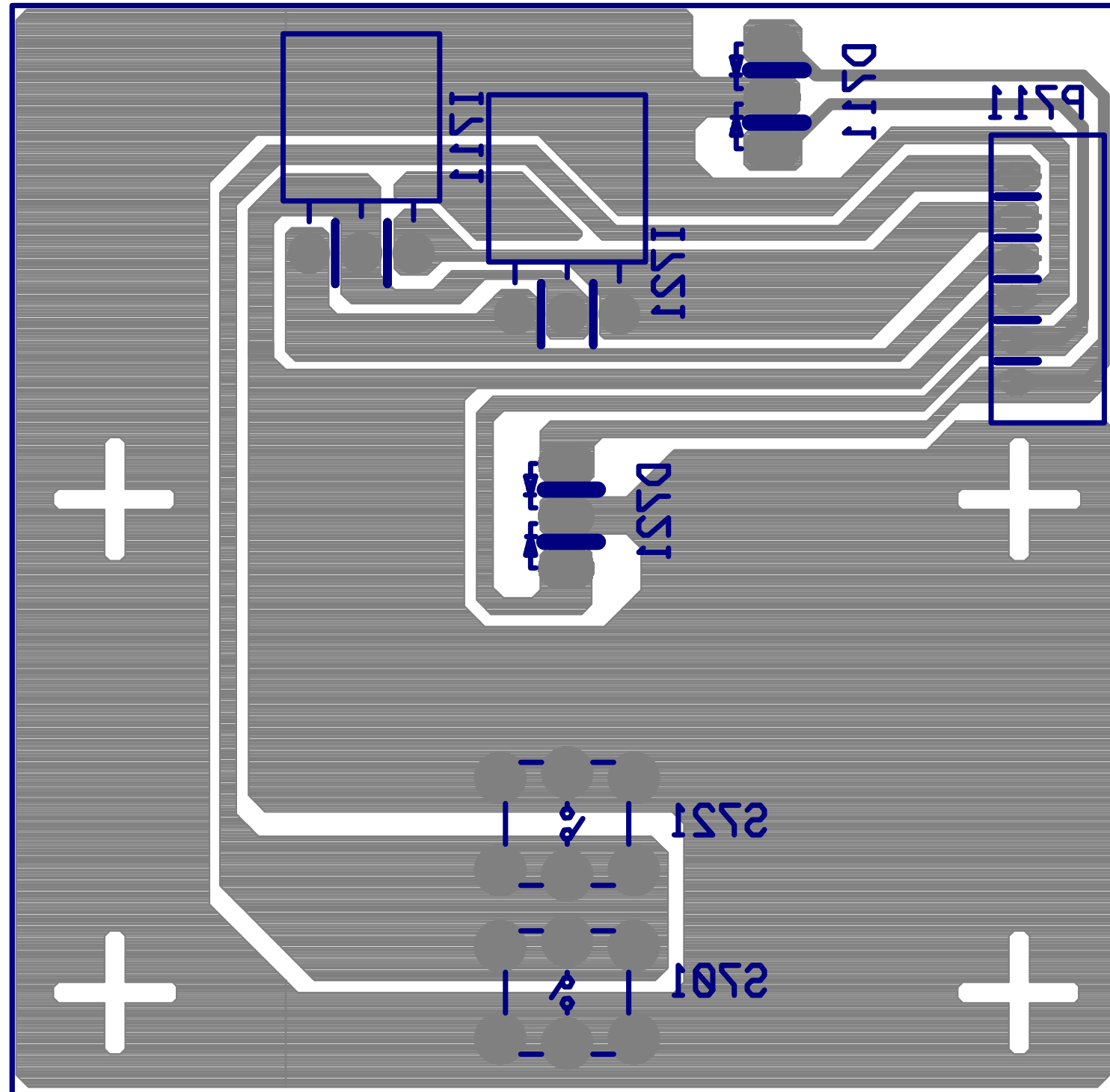

Reader's Response

Dear Readers:

Thank you in advance for your feedback on our Service Manual, which allows continuous improvement of our products. We would appreciate your completion of the Assessment Matrix below, for return to ViewSonic Corporation.

Assessment

A. What do you think about the content of this Service Manual?

<i>Unit</i>	<i>Excellent</i>	<i>Good</i>	<i>Fair</i>	<i>Bad</i>
1. Precautions and Safety Notices				
2. Service Tool & Equipment Required				
3. Specification				
4. Adjustment Procedure				
5. Packing For Shipping And Disassembly Procedure				
6. Troubleshooting Flow Chart				
7. Exploded View				
8. Recommended Spare Parts List				
9. Block Diagram				
10. Schematic Diagrams				
11. Working Theorem				
12. Wiring Diagram				
13. PCB Layout Diagrams				

B. Are you satisfied with this Service Manual?

<i>Item</i>	<i>Excellent</i>	<i>Good</i>	<i>Fair</i>	<i>Bad</i>
1. Service Manual Content				
2. Service Manual Layout				
3. The form and listing				

C. Do you have any other opinions or suggestions regarding this service manual?

Reader's basic data:

Name:		Title:	
Company:			
Add.:			
Tel:		Fax:	
E-mail:			

After completing this form, please return it to ViewSonic Quality Assurance in the USA at facsimile 1-909-839-7943. You may also e-mail any suggestions to the Director, Quality Systems & Processes (marc.maupin@viewsonic.com)