



DOCUMENT CHANGE NOTICE

DCN NUMBER: **2207** VERSION:

Change / Release Classifications
 Critical Process Impact
 Routine Initial Release

DOCUMENTS AFFECTED		REVISION	
TITLE	NUMBER	From	To
Manual, Service P90f-1	P90f-1_SM_525		1a

Kevin Yang
 Originator: _____ Date: _____
 Email Address: kevin.yang@ ViewSonic.com
CSJ 5-22-02
 Department Manager: _____ Date: _____
 Approved Rejected

REASON FOR CHANGE: (Samples: Initial release, Major Re-Write, Add, Revise, or Delete)

Initial Release.

DESCRIPTION OF CHANGE:

DOC. CONTROL CHECKLIST

- ISO Document(s) Code: _____
 - Posting (Intradoc)
 - Scanning Complete
 - E-Mail Notification
 - DCN Closed
 - Electronic Files(s) received (If Applicable)
 - Workflow Routing Complete
- Other: _____

Processor: _____ Date: _____

AFFECTED PARTY:

Dept. Name: _____
 Dept. Name: _____
 Dept. Name: _____
 Dept. Name: _____
CSJ 5/22
 Doc. Ctrl. Mgr. Date:

APPROVERS:

Kevin Yang 5/22/02
 Author: _____ Date: _____
Tony Chen
 Co-Spsr #1: _____ Date: _____
 Co-Spsr #2: _____ Date: _____
 Co-Spsr #3: _____ Date: _____
 Co-Spsr #4: _____ Date: _____

= Completed by Document Control

Service Manual

ViewSonic P90f-1 Model No. VCDTS23483-1

19" Digital Controlled Color Monitor



(P90f_SM_525 - Rev. 1a - April 2002)

Copyright

Copyright © 2002 by ViewSonic Corporation. All rights reserved. No part of this publication may be reproduced, transmitted, transcribed, stored in a retrieval system, or translated into any language or computer language, in any form or by any means, electronic, mechanical, magnetic, optical, chemical, manual or otherwise, without the prior written permission of ViewSonic Corporation.

Disclaimer

ViewSonic makes no representations or warranties, either expressed or implied, with respect to the contents hereof and specifically disclaims any warranty of merchantability or fitness for any particular purpose. Further, ViewSonic reserves the right to revise this publication and to make changes from time to time in the contents hereof without obligation of ViewSonic to notify any person of such revision or changes.

Trademarks

ViewSonic is a registered trademark of ViewSonic Corporation.
All other trademarks used within this document are the property of their respective owners.

Revision History

Revision	Date	Description Of Changes	Approval
1a	4/17/02	Initial Release DCN-2207	K.Yang

TABLE OF CONTENTS

1. PRECAUTIONS AND NOTICES.....	1~2
2. SPECIFICATIONS	3
3. TIMING CHART	4
4. CONTROL LOCATION AND FUNCTIONS	5~8
5. MECHANICAL PARTS & MECHANICAL ASSEMBLY	9~10
6. CONNECTOR PIN ASSIGNMENTS.....	11
7. MONITOR INSTALLATION.....	12
8. ELECTRONIC CIRCUIT DESCRIPTION	13~20
9. ADJUSTMENT	21~27
10. TROUBLESHOOTING FLOW CHART.....	28~34
11. REPLACEMENT PARTES LIST.....	35~57
12. SCHEMATIC DIAGRAMS	58~61
13. PCB LAYOUT.....	62~68

1. PRECAUTIONS AND NOTICES

1.1 SAFETY PRECAUTIONS

- 1) Observe all cautions and safety related notes located inside the display cabinet and on the display chassis.
- 2) Operation of this display outside the cabinet or with the cover removed, involves at shock hazard from the display power supplies. Work on the display should not be attempted by anyone who is not thoroughly familiar with precautions necessary when working on high voltage equipment.
- 3) Do not install, remove or handle the picture tube in any manner unless shatter-proof goggles are worn. People not so equipped should be kept away while handling picture tube. Keep picture tube away from body while handling.

1.2 Observe all cautionary and safety related notes located on the chassis, cabinet and display tube.

1.3 Operation of the monitor with the back cover removed presents a potential shock hazard. Only personnel familiar with the precautions necessary for safe working on high voltage equipment should attempt to carry out servicing.

1.4 Always wear shatter proof goggles when removing, installing or generally handling the picture tube. People not so equipped should be kept at a safe distance when any such handling is being undertaken. Do not handle the picture tube by the neck of deflection coil. Do not carry the picture tube resting against the body.

1.5 The picture tube is designed and constructed to limit X-Radiation to a safe level during normal operation. To maintain the required level of protection and safe operation, replacement tubes must be correctly adjusted and any protective circuits must not defeat.

1.6 IMPORTANT-Safety Tests

After servicing, and before returning the monitor to the user, a thorough safety test must be carried out to ensure there is no potential shock hazard to any operator(s) using the monitor. All the following test must be performed. A monitor failing any of these tests should be rejected and have the problem rectified.

1.7 A.C. Leakage Test

Remove the power source. Connet the monitor to the circuir as in figure 1 below. Switch the monitor on/off switch to on. A reading of less than 3.5mA should obtained (ref. EN60950).

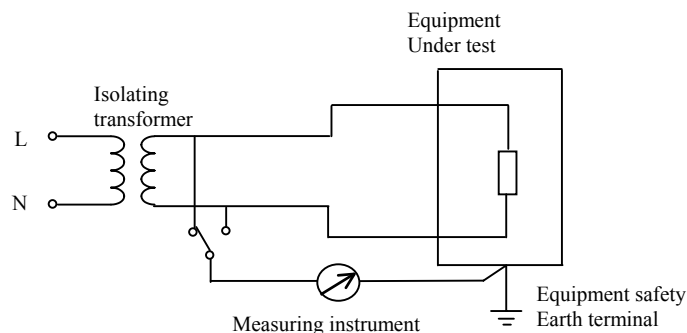

Fig.1 Measurement of AC Leakage Current.

1.8 Voltage Breakdown Test

Connect the live and neutral connections together. Switch the monitor on/off switch to on Apply 1500VAC RMS or 2250VDC, 50Hz for one minute between live and neutral shorted together and earth. Ensure no voltage breakdown occurs.

1.9 Earth Resistance/Continuity Test

Measure the resistance between the signal cable metal shell and the earth pin in the A.C. socket. At a current of 25 amperes the resistance should be less than 100m.

NOTE:A portable appliance tester (PAT) is a suitable instrument to use for the above safety tests.

1.10 H.V. Over Voltage Protection (Required for X-Radiation Safety)

Adjust R176 slowly anti-clockwise until the over voltage protection circuit is activated, and the high voltage must be less than 33KV at this moment. After test, R176 should be adjusted back to normal(=26.2KV)

CAPACITOR:

C850	400V	4700PFM	CAPACITOR.CERAMIC	5230105501
C851	400V	4700PFM	CAPACITOR.CERAMIC	5230105501
C135	250V	33UFM	CAPACITOR.ELECTROLYTIC	5214433012
C139	100V	330UFM	CAPACITOR.ELECTROLYTIC	5214019612

RESISTOR

R827		1K	RESISTOR.VS	5162161020
------	--	----	-------------	------------

SEMICONDUCTORS

I101, I803	UC3842N		IC LINEAR	6644063111
I301 (RA)	TDA9116 SDIP32		IC.LINEAR A.S.D.C.	6644076308
I301 (RB)	TDA9113 SDTP-32		IC.LINEAR A.S.D.C.	6644076305
I310	TDA8172 7P		IC.LINEAR	6644076000
IA01	NT68F62U		IC.LSI MCU FLASH MTP	6647008204
Q801	2SK2648-01		TR FET MOS	6626003208
Q433	2SC5587AS		TR NPN HF	6621040405
Q121	2SK2843		TR FET MOS	6626003203
D807	RD20EB2-T1		TR PNP HF.	6615011831
D827	HZ5C1		DIODE ZENER	6615007834

OTHERS

SR801	OSA-SS-212DM5		RELAY	5054613402
F801	250V/3.15A		FUSE	5054431539
T801	TPW-697		POWER TRANSFORMER	5061369700
T101	TFB-280L		TRAQNS.FLYBACK COLOR	5062628032
V901 (CA)	M46QDG423X04		CCRT/DY	5051286325

2. SPECIFICATIONS

CDT	Size and deflection angle		19 inch 90 degree
	Screen type		Flatron
	Horizontal pitch / Dot pitch		0.24mm
	Surface treatment		Anti-static AR coating
	Transmission rate		46%
Scanning Freq.	Horizontal Frequency		30kHz to 110KHz
	Vertical Frequency		50Hz to 180Hz
Video amplifier	Applicable pixel rate		265MHz
Resolution	Maximum		1600 x 1200 @85Hz
Modes	Factory preset/User modes		12/ 14
Power	AC input range		100 to 240 Vac
	Max. power consumption		<130W
	Power Management	Suspend	<4W
Off		<4W	
User controls	Power Switch		On/off with Led indicator
	Up/Down adjustment Key		2 key pads for adjust Up / down keys are direct access for Contrast And Brightness adjustment
	"2" Key		As a select key/ go to next sub menu
	Auto-size Key		Auto-sizing
Rear connection	Signal connections	Standard Model	1.8 m signal cable with 15Pin D shell miniature male connector.
	Power input		AC socket with 1.8 meter cable
Agency Approvals	European	Safety	CB,BSM2,VPSB,C-TICT,TUV/S(Argentina)
		Emissions	EN50081-1
		Immunity	EN50082-1
		Ergonomic	ISO9241Paart3 &ISO9241Part8 ZH1/618
		VLMF	MPRII
	USA	Safety	UL1950
		Emissions	FCC class B
		X-ray	DHHS
	Japan	Safety	EIAJ
		Emissions	VCCI category 2
Plug and Play	DDC 1/2 B		Version 2
Environmental Conditions	Operating Temperature		10°C to 40°C
	Storage Temperature		-30°C to +60°C
	Operating Humidity		10% to 90%
	Storage Humidity		10% to 95 %
Dimensions	W x H x D		475.8 mm x 492.1mm x470.7mm
Weight	Kg		24.05Kg (Gross)

3. TIMING CHART

Mode 1~ 13 : Preset Mode

Mode 14,15,16: Only for H-size limitation and Auto-size

Mode NO.	1	2	3	4	5	6	7	8	Unit
Pixel Clock	25.175	25.175	30.24	56.25	78.75	80.0	94.5	135	MHz
Resolution	640x400	640x480	640x480	800x600	1024x768	1024x768	1024x768	1280x1024	
Horizontal Frequency	31.469	31.469	35	53.674	60.023	60.241	68.677	79.976	KHz
(A) Horizontal Period	31.779	31.778	28.571	18.631	16.660	16.6	14.561	12.504	usec
(B) Horizontal Pulse Width	3.813	3.813	2.116	1.138	1.219	1.2	1.016	1.067	usec
(C) Horizontal Back Porch	1.907	1.907	3.175	2.702	2.235	2.2	2.201	1.837	usec
(D) Horizontal Active Area	25.422	25.422	21.164	14.222	13.003	12.8	10.836	9.481	usec
(E) Horizontal Front Porch	0.637	0.636	2.116	0.569	0.203	0.4	0.508	0.119	usec
(F) H. Sync. Polarity	-	-	-	+	+	-	+	+	
Vertical Frequency	70.087	59.94	66.667	85.061	75.029	74.927	84.997	75.025	Hz
(O) Vertical Period	14.269	16.683	15	11.756	13.328	13.346	11.765	13.329	msec
(P) Vertical Pulse Width	0.064	0.064	0.086	0.056	0.050	0.050	0.044	0.038	msec
(Q) Vertical Back Porch	1.112	1.049	1.114	0.503	0.466	0.498	0.524	0.475	msec
(R) Vertical Active Area	12.712	15.253	13.714	11.179	12.795	12.749	11.183	12.804	msec
(S) Vertical Front Porch	0.381	0.317	0.086	0.018	0.017	0.049	0.014	0.012	msec
(T) V. Sync. Polarity	+	-	-	+	+	-	+	+	
(U) Interlaced	No	No	No	No	No	No	No	No	
Mode NO.	9	10	11	12	13	14	15	16	Unit
Pixel Clock	157.5	202.5	229.5	261	57.28	40	49.5	36	MHz
Resolution	1280 x 1024	1600x1200	1600x1200	1792x1344	832x624	800x600	800x600	640x480	
Horizontal Frequency	91.146	93.75	106.25	106.27	49.725	37.8	46.875	43.269	KHz
(A) Horizontal Period	10.971	10.667	9.412	9.41	20.111	26.4	21.333	23.111	usec
(B) Horizontal PulseWidth	1.016	0.948	0.837	0.828	1.117	3.2	1.616	1.556	usec
(C) Horizontal Back Porch	1.422	1.501	1.325	1.349	3.910	2.2	3.232	2.222	usec
(D) Horizontal Active Area	8.127	7.901	6.972	6.866	14.524	20	16.162	17.778	usec
(E) Horizontal FrontPorch	0.406	0.316	0.279	0.368	0.560	1	0.323	1.556	usec
(F) H. Sync. Polarity	+	+	+	-	-	+	+	+	
Vertical Frequency	85.024	75	85	74.997	74.5	60	75	85.008	Hz
(O) Vertical Period	11.761	13.333	11.765	13.334	13.414	16.579	13.333	11.764	msec
(P) Vertical Pulse Width	0.033	0.032	0.028	0.028	0.060	0.106	0.064	0.069	msec
(Q) Vertical Back Porch	0.483	0.491	0.433	0.649	0.784	0.607	0.448	0.578	msec
(R) Vertical Active Area	11.235	12.8	11.294	12.647	12.549	15.84	12.8	11.093	msec
(S) Vertical Front Porch	0.011	0.011	0.009	0.009	0.021	0.017	0.021	0.023	msec
(T) V. Sync. Polarity	+	+	+	+	-	+	+	+	
(U) Interlaced	No	No	No	No	No	No	No	No	

4. CONTROL LOCATION AND FUNCTIONS

Front

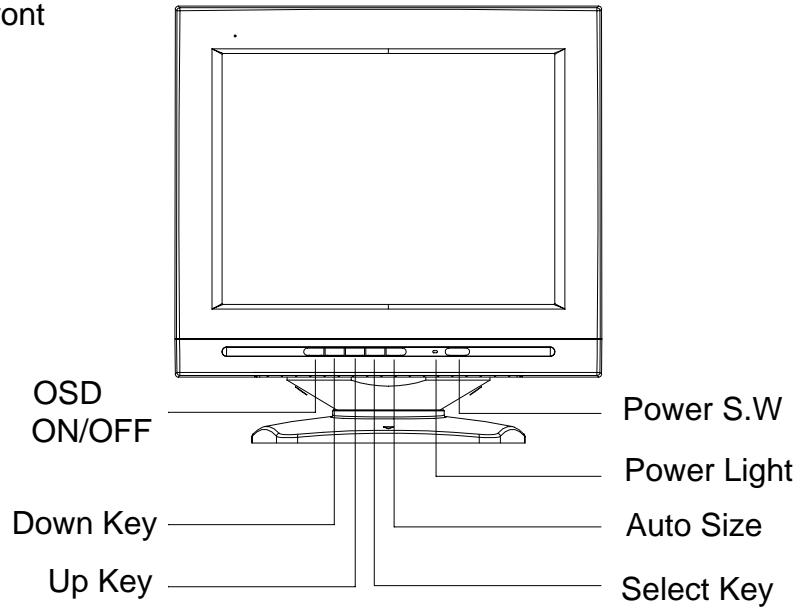

Rear

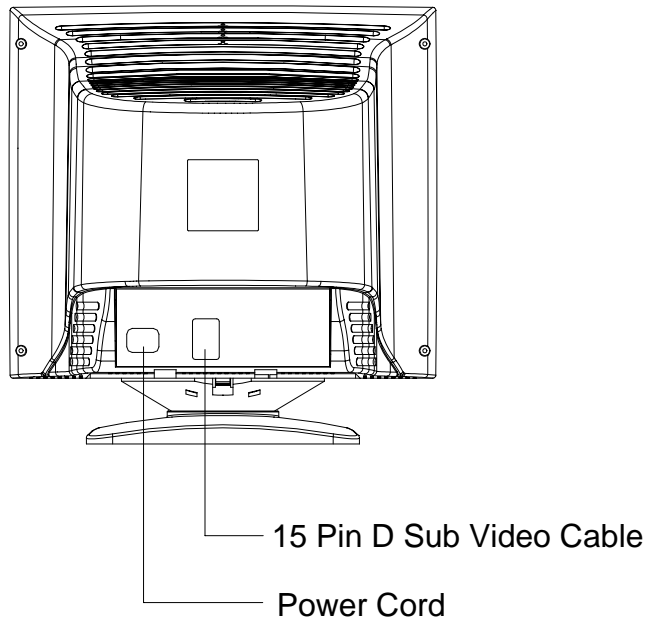

Function Keys Description:

(a) Key function:

Power switch: This is a “software Key”, Turns the display on and off. The power indicator will lit “Green” when the display is on.

“1” key: Turn on /off OSD menu / Exist this menu to go back previous menu.

▽ : Down side to select item / decrease value.

△ : Up side to select item / increase value.

▽, △ keys are direct access for Contrast and Brightness adjustment.

(b) “2” key: a select key / go to next sub menu.

(c) Pressing “2” & power keys at same time will enter the factory optimized OSD Menu.

(d) Selected  icon and then pressing “2” key will do demagnetize CDT, if pressing maintain to more than 3 sec will de force MCU to enter burn in state for production line burning.

(e). Press  key will auto adjust the display.

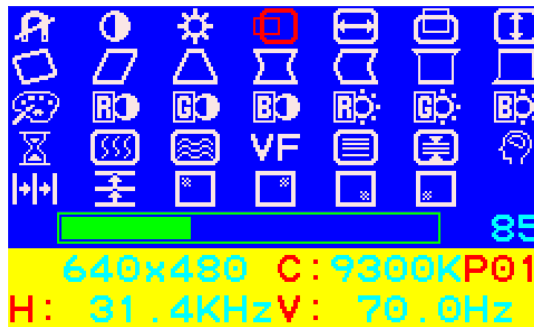

Factory OSD Menu

OSD menu descriptions:

Press “1” key to display a basic main menu (1) shown as below.

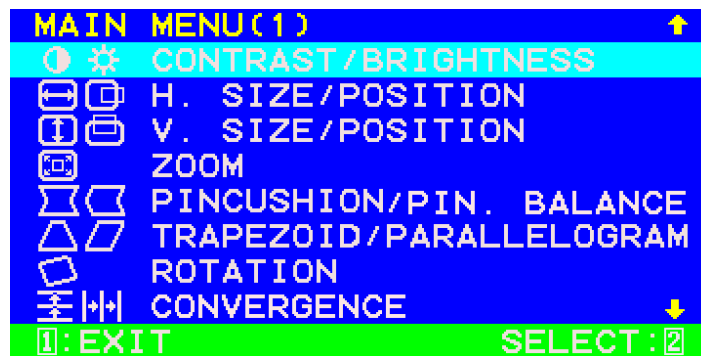

Using ▽ and △ keys to move a cyan window bar get your desired items. If it is selected, then pressing “2” key to display Sub menu as below to start adjustment.



Use ▽ and △ to decrease / increase value on selected item. Noted that the menu can do two items adjust pressing “2” change to another one in toggle.

In main menu (1), selected “main menu (1) and then pressing up or down key to the top or bottom of this menu, the next pressing will go to main menu(2) as below to others

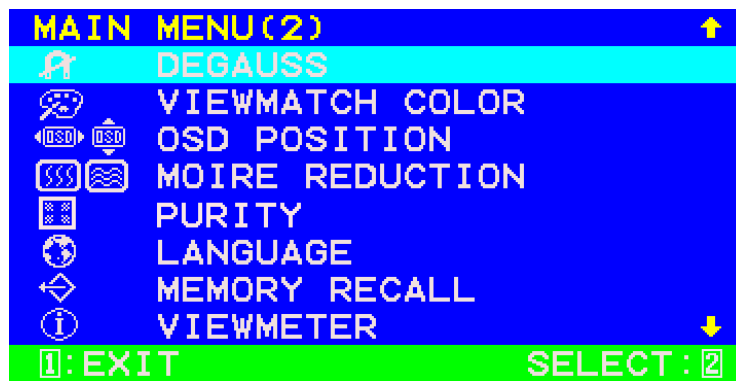

FIGURE 2 (USER MODE OSD MENU 2)

In main menu 2, if selected “ VIEWMATCH COLOR”, then pressing “2” key will display color sub menu as following.



The three default color modes such as 9300k, 6500k, 5000k only can be set in factory, means, they can read and display only in this menu.

If selected “user color”, then pressing “2” key will display next sub menu as below to start color adjustment.



In main menu (2), if selected "LANGUAGE", then pressing "2" key will display next sub menu as below to language. Select as below:

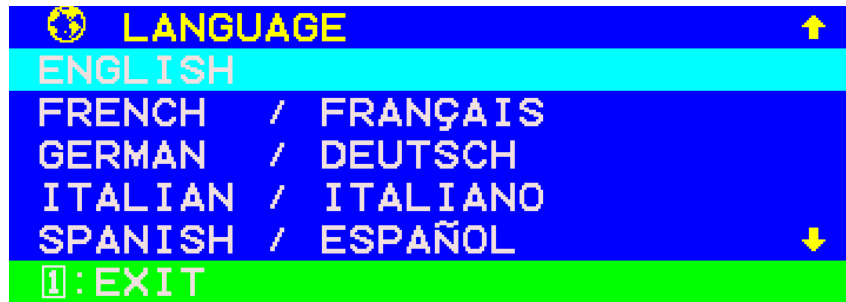

If selected "view meter", and then pressing "2" key will display next sub menu as below to show timing information.



5. MECHANICAL PARTS & MECHANICAL ASSEMBLY

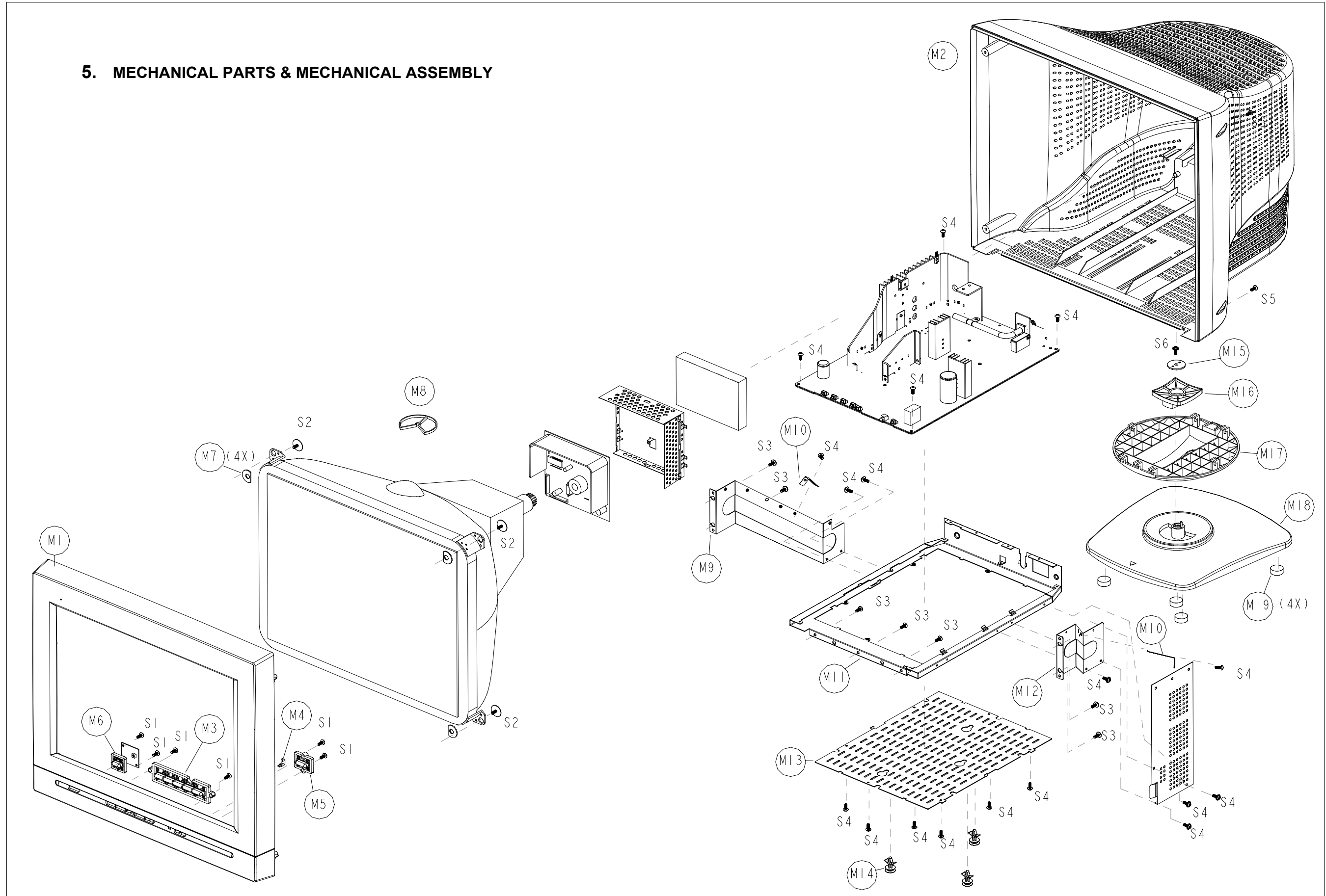

P90f Mechanical Parts list

NO.	DESCRIPTION	PART NO.	QTY
M1	FRONT COVER	5642286900	1
M2	BACK COVER	5642287000	1
M3	FUNCTION KEY	5642846000	1
M4	POWER LIGHT PIPE	5640328200	1
M5	POWER KEY	5642845900	1
M6	RUBBER WASHER	5642020001	4
M7	RING CABLE	5642655600	1
M8	LEFT BRACKET	5648734100	1
M9	SPRING FINGER	5648006000	2
M10	MAIN CHASSIS BRACKET	5648734300	1
M11	RIGHT BRACKET	5648734200	1
M12	REAR BRACKET	5648734400	1
M13	PCB SPACER SUPPORT	5642670400	3
M14	SWIVEL WASHER	5642722300	1
M15	SWIVEL CLAMP	5642676500	1
M16	SWIVEL	5641410300	1
M17	BASE	5641410400	1
M18	FOOT PAD	5642022700	4
S1	SCREW BTBW M3X10	7000305022	4
S2	SCREW PHB+CW+RW M5X24	7190561001	4
S3	SCREW PZP M4X14	7134251982	7
S4	SCREW BTBW M3X8	7000305012	16
S5	SCREW PZP M4X16	7134252282	4
S6	SCREW PZP M4X20	7190562424	1

6. CONNECTOR PIN ASSIGNMENTS

6-1 The Pin-assignments of the 15pin D-sub male miniature connector are shown below:

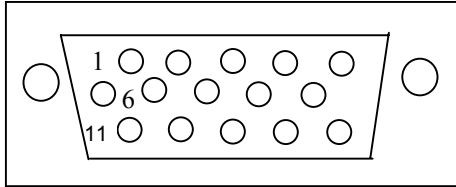

6-2 15 Pin Min D-sub male connector

PIN NO	PIN DESCRIPTION
1	RED
2	GREEN
3	BLUE
4	NO CONNECTION
5	GROUND
6	R-GROUND
7	G-GROUND
8	B-GROUND
9	+5V PC97
10	GROUND
11	NO CONNECTION
12	SDA FOR DDC
13	H.SYNC.
14	V.SYNC.
15	SCL FOR DDC

7. MONITOR INSTALLATION

Monitor Installation

How to Install the Connections to your PC

7-1. Your monitor has two connection cables:

.A signal cable which connects to your computer's VGA connector. Which is colored blue.

7-2. To ensure your safety when connecting the cable, always follow these six steps:

(I). Turn off the power to your computer and peripheral equipment.

(II). Position the monitor and computer so that you can easily access the rear panel of each unit.

(III). Connect the blue-colored video signal cable D-sub connector to the signal connector on the graphics board (VGA connector) on your computer. (See your system user's guide for the exact location of your VGA connector.)

(IV). Tighten the screws on the signal cable connector to prevent it from coming loose, and to prevent radio and TV interference.

(V). There are two kinds of Power Cord, one is to connect between your monitor and the wall outlet, the other type is to connect between your monitor and PC.

- You might have either of the above two type of power cord. To connect the power cord between monitor and PC, you have to plug one-end of the power cord to the monitor power input socket, and plug the other end of the power cord to the PC power output feed.

- To connect Power Cord between your monitor and wall outlet , you have to connect the power cord to the monitor power input socket on back of the monitor .Plug the other end of the power cord into your surge protector or properly-grounded electrical outlet

8. ELECTRONIC CIRCUIT DESCRIPTION

8-1 SWITCHING MODE POWER SUPPLY SECTION

8-1-1 Features

1. AC input: 100Vac – 240Vac.
2. When Power Saving activated, change feedback to reduce the output voltage and shut down timebase and video circuit operation, thus power reduce to be less than 5W.

8-1-2 Circuit description:

8-1-2-1 EMI Noise Filter

8-1-2-2 C802 and C803 build as Y capacitors, C804 is X capacitor, L801 and L802 are Common Mode Choke, those build as a two steps Noise filter.

8-1-2-3 Power supply activation:

The rectified voltage across C809 charge C815 through R809, R810, R811, R812, Q810, and D822, When UC3842 pin 7 rise up to 14V, Q816 on and Q810 off. C817 charge to 55Vdc, this voltage is ready for B+ of UC3842 at Pin7 during Suspend, or Off Mode(> 10V). C844 also provides a voltage for UVP (Vac under voltage protection). When C844 voltage is too low, Q814 turns off, voltage at pin 2 of UC3842 is over 2.5Vdc, UC3842 will be turned off and protected.

8-1-2-4 Degaussing circuit

Degaussing coil is connected to relay (SR801), and controlled by MCU through Q856 Q857, When power is turned on, SR801 close, and automatic demagnetization operate for a few seconds, then SR801 open. Degaussing also can be operated by pressing degaussing key on the front bezel.

8-1-2-5 UC3842 PWM controller

UC3842 is a current feedback PWM controller:

Pin1---is feedback positive end.

Pin2---190V and 9V at secondary side of power transformer provide a sampling voltage to pin 2 of UC3842 via I808, I807.

Pin3---is a current feedback input, when it is over 1V, no output at pin6 to drive output stage.

Pin4---This pin determine the operating frequency---which is trig by a sync. signal coming from I810.

Pin6---this output drive power MOSFET (Q801).

8-1-2-6 Output voltage feedback control theory

Feedback control is sampled from 190Vdc and 9Vdc at secondary side, through VR R827 2.5V feedback to reference pin of I808(R), then I 807 coupled to pin 2 of UC3842. When output voltage rise up, I 808 Reference voltage(R) rise up too, Cathode(K) voltage goes down. More conduction on I807 in turns cause voltage across R826 to rise. UC3842 pin2 voltage rise to reduce the duty at output pin6. Q801 conduct less to reduce the secondary side voltages, thus to stabilize the DC voltages at secondary side.

8-1-2-7 Over-voltage protection

When output voltage are too High, voltage across C817 will be high and voltage drop on R872 is also high. It will force Q808, Q807 to conduct and pin8 of UC3842 to ground. Thus UC3842 stop to operate.

8-1-2-8 Under-voltage protection

If Ac input voltage is too low, voltage across C844 will be too low that force Q814 to turn off and voltage across C822 rise up. When pin2 of UC3842 rise up to 2.5V, pin6 stop to drive output. Thus Q801 is protected.

8-1-2-9 Synchronization circuit

UC3842 working frequency is fixed at 33.3 Khz by adjusting R817A.

8-1-2-10 Power Saving control

At normal operating state, Q811 on, Q812 off, output voltage are normal. At stand-by or suspend Mode, Q811 off, Q812 on, feedback voltage increase to reduce output voltages down to 1/3 of normal approx.. If enter off Mode, Q811 and Q812 Off, feedback voltage increase more to reduce output voltages down to

1/4 of normal. And the another great frequency control is to connect R821 to set power supply working at low frequency about 10 Khz. By above two ways, it can meet DPMS and NUTEK requirement.

When monitor enter power saving state, voltage across C817 controlled by I804, Q815 continue to supply pin 7 of UC3842 to operate and voltage across C811 controlled by Q805, Q806 continue to supply 5V for IA01 to stand by.

8-2 DIGITAL CONTROL CIRCUIT(Signal control by Microprocessor unit; IA01)

Horizontal and vertical sync. signal coming from CRT drive Board(PWB—0237)are fed into pin41(H. sync.) and pin42(V. sync.) of IA01. When the power cord plug in, pin4 of IA01 reset and IA01 start to check if the sync. Signals are exist at pin 41 and pin 42. The control tables are as follows:

Power state	Normal	Standby/suspend	Off
Pin42,Pin41	V sync. H. sync.	V or H. sync. exist	Both sync. not exist
Pin23	Logic high	Logic low	Logic low
I804	ON	OFF	OFF
Pin24(G)	High	High	Low
Pin22(A)	Low	High	High
LED	Green	Yellow	Amber

Standby/suspend Mode:

If only one of the sync signal exist, pin23 of IA01 change to low and turns off Q811 and pin21 of IA01 change to high and turns on Q812. The feedback will be reduced through I808 and cut down all the secondary output voltages. In order to maintain the supply voltage for I803 PWM, I804 is then turned on, Q815 turns on too. The supply voltage from D812 is then connected to Vcc of I803. The off signal from pin23 of IA01 also turns Q805, Q806 on, the supply voltage at input of I802 is then taken from D804 to keep 5V for IA01 continue working. In order to keep stand-by voltage for CRT heater, Q867 continue to conduct by the logic from pin21 of IA01.

Off mode:

When both sync. Signals are absent, IA01 will send a logic. Low at pin 23 and pin21 to turn Q811, Q812 off. The secondary voltages will be reduced further, and Q867, Q866 are turned off. The heater voltage become zero for further lower power consumption than stand-by/suspend Mode.

Normal Power supply operation:

When the sync signals are both exist, then IA01 will send Low at pin 13 to switch on the relay BR801 via Q104 and Q104A and thus produce a very high current circulate the degaussing coil and this signal will sustain for a certain period. Thus the display is demagnetized

The sync signals are buffered by IA01 and output at pin 41, 42 to synchronize the timebase controller I301. IA01 will also initiate I301 by IIC bus build by pin 28(C.SCL), pin 27(C.SDA). This IIC bus is also responsible to initiate the video pre-amplifier I901 and OSD I903. After the initiation is completed I301, I901 and I903 will operate normally. This IIC bus also provides Purity control, through P421, connect to PWB-0417, purity control board.

Pin 17 to pin 20 and pin32 provide the logic to control the horizontal CS linear correction circuit according to the horizontal frequency range as the following table.

P90f CS Table

HS \ CS	CS4	CS3	CS2	CS1	CS0
MCU Pin	32	17	18	19	20
Capacitor	C425	C421	C420	C419	C423
Hf < 32KHz	H	H	H	H	H
32KHz < Hf <= 36KHz	H	H	L	H	L
36KHz < Hf <= 40KHz	H	H	L	L	L
40KHz < Hf <= 45KHz	L	H	H	H	H
45KHz < Hf <= 52KHz	L	L	H	L	H
52KHz < Hf <= 58KHz	L	L	H	L	L
58KHz < Hf <= 65KHz	L	H	L	H	H
65KHz < Hf <= 70KHz	L	L	L	H	L
70KHz < Hf <= 86KHz	L	H	L	L	H
86KHz < Hf <= 96KHz	L	H	L	L	L
Hf > 96KHz	L	L	L	L	L

Pin 36 (F/V) provides horizontal C linearity control.

Pin 40 provide rotation PWM to rotation circuit build by Q701, Q702 and Q703 and thus control the current circulate the coil around the deflection yoke to rotate the display.

Pin 1 provide Horizontal convergence control through Q426, Q427, Q428.

Pin39 provide Vertical convergence control through Q305, Q306, Q307.

Pin 31 short to ground via 15pin D sub connector when it connect to PC. When it is disconnected, power saving feature is switch off, monitor will display "NO SIGNAL" as self test pattern.

IA02 is E²PROM for IA01 to save settings of all modes and DDC data.

8-3 TIMEBASE CIRCUIT



8-3-1 TIMEBASE CONTROL (I301), HORIZONTAL

I301 is an IIC control Time-base processor, By IIC bus pin30, 31(SDA,SCL) it can communicate with IA01(MCU)

H. sync., V. sync feed from IA01 pin41,42 to I301 pin1 ,2. When the H. Freq. is over 110kHz or below 30kHz, I301 will shut down to protect the Horizon. output CKT from being damaged. The Horizon. oscillator is build by C303 and R301 and determine the Horizon. frequency range.

C304, C305, R302 build up PLL 1 loop filter,

Via  Icon, the IIC-bus allows a linear adjustment of the Horizon. position by comparing relative phase of horizontal Sync. and oscillator saw-tooth(in PLL 1 loop) and feedback from Horizon. output stage.

 and  correction of pin unbalance and parallelogram are done by modulating the phase between oscillator saw-tooth and horizontal. flyback (in loop PLL2)

The PLL2 phase detector is similar to PLL 1 detector and compares the Horizon. flyback pulse at pin 12 with the oscillator saw-tooth wave-form. The controlled currents are independent of Horizon. freq. The PLL 2 thus compensates for the delay in the output horizontal deflection CKT by adjusting the phase of the HDRV (pin26) output pulse.

8-3-2 HORIZONTAL OUTPUT STAGE

The horizon. drive pulse output at pin 26 is pulled up to 12V to drive Q404 and then coupled via T401 to output transistor Q403 for on-off control. Thus saw-tooth current flow through Horizon. Deflection Yoke is obtained.

The function of C-correction is to correct the asymmetrical non-linearity of picture. L402, L406 and Horizontal Yoke are in series for C-correction. Pin36 of IA01 provides a voltage which depends on Horizontal frequency to control L402 via Q405, thus the inductance of L402 changes according to the Horizontal frequency to correct the linearity.

The function of S-correction is to correct the symmetrical non-linear distortion equidistant lines. C416, C423, C419, C420, C421, C425 are S-correction capacitors, also they block the DC voltage to the Yoke. C416 is the fixed one, the others are controlled by IA01 via Q417, Q411, Q413, Q415, and Q418 switches. When any switch turns on, the accordingly capacitor is in parallel with C416. The switches on-off depend on the Horizontal Frequency.

L406 is controlled by pin32 as well, when Horizon. freq. is over 40kHz , L406 is parallel with L402.

They are:

Rf \ CS	CS4		CS3	CS2	CS1	CS0
MCU Pin	32		17	18	19	20
Capacitor	C425	L406	C421	C420	C419	C423
Hf <32KHz	ON	OFF	ON	ON	ON	ON
32KHz<Hf<=36KHz	ON	OFF	ON	OFF	ON	OFF
36KHz<Hf<=40KHz	ON	OFF	ON	OFF	OFF	OFF
40KHz<Hf<=45KHz	OFF	ON	ON	ON	ON	ON
45KHz<Hf<=52KHz	OFF	ON	OFF	ON	OFF	ON
52KHz<Hf<=58KHz	OFF	ON	OFF	ON	OFF	OFF
58KHz<Hf<=65KHz	OFF	ON	ON	OFF	ON	ON
65KHz<Hf<=70KHz	OFF	ON	OFF	OFF	ON	OFF
70KHz<Hf<=86KHz	OFF	ON	ON	OFF	OFF	ON
86KHz<Hf<=96KHz	OFF	ON	ON	OFF	OFF	OFF
Hf>96KHz	OFF	ON	OFF	OFF	OFF	OFF

8-3-3 SUPPLY VOLTAGE CONTROL FOR HORIZONTAL DEFLECTION

The B+ control function block is included in I301 which consists of an operational Trans-conductance amplifier, a voltage comparator, a flip-flop and a discharge circuit. Pin 28 of I301 is a drive voltage which consists of horizontal width, pincushion, and trapezium and pin-corner correction. This voltage is controlled by IA01 via IIC bus. The drive voltage feed into pin 15 (BIN) of I301. The operation frequency of the B+ control block is the same as horizontal frequency. The B+ drive output of the control block is at pin 28(BDRV), this drive voltage switch Q402 on-off via a buffer build by Q400 and Q401. Q402, act as an step down DC

converter to drive horizontal deflection output Q433 via L401. The width, pincushion, trapezium information are modulated on the DC converter by changing the duty of the B+ drive.

Moreover, the B+ duty is controlled with a charging circuit at same time. When the Q302 is OFF, the voltage at pin16 of I301 will linearly increase with a charge time of determining by R326 and C308 to modulate B+ duty

Horizontal DC centering circuit is build by Q423, Q424. By controlling the small current flow in or out of L405, it will provide DC center compensation for CDT.

8-3-4 TIMEBASE CONTROL (I301), VERTICAL

The vertical free running frequency is determined by C312 (pin 22 of I301).The amplitude of the outputat pin 23 can be adjusted via  Icon.

 Icon provides a DC shift at the saw-tooth output at pin 23 and the EW drive output EWDRV (pin24) in such a way, that the whole picture moves vertically while maintaining the correct geometry.

The adjustments for vertical size and vertical position also affect the wave-forms of horizontal pincushion, vertical linearity, and vertical linearity balance, focus parabola, pin unbalance and parallelogram correction. The result of this interaction is that no readjustment of these parameters is necessary after an adjustment of vertical picture size or position.

8-3-5 VERTICAL OUTPUT STAGE

The power amplifier driving the vertical yoke assembly is a DC design-based on power amplifier I310 TDA8172.

The vertical deflection coil is connected to pin5 of I330 via P401A. The saw-tooth signal is derived from Pin 23 of I301 and fed to pin1 of I310 via R306 / C322. The DC bias voltage is derived from pin13 of I301 and fed to pin7 of I310 via derived R325 / R327 to optimize the vertical position.

There are two supply voltage for I310, -15V is applied at pin4 via R384, +15V DC voltage is applied at pin2 and pin6 via D310 for the output stage during the retrace time. The supply voltage for the output stage during the retrace time is derived from the fly-back generator output on pin3 of I310 and applied through C388 to pin6.

8-4 HIGH VOLTAGE GENERATOR AND BLANKING CIRCUIT

I101 is a current mode PWM controller which provides the drive signal for high voltage generator. It is synchronized by horizontal blanking signal coming from deflection circuit via Q111. Q121, Q124 are high voltage output switches. T101 provide the high voltage (26.2kV) to CDT anode. Pin 13 provide feedback to pin2 of I101 to control the duty when high voltage is varied according to the beam current. Thus it gives a very good high voltage and size regulation. A very precise geometry distortion is achieved. R176 provides high voltage adjustment.

Pin5 of T101 senses high voltage for OVP protection. When high voltage is over 33kV, it raises the emitter voltage of Q114. When emitter voltage of Q114 is 6.8V higher than Q115 collector, Q116 start to conduct and shutdown the PWM (I101) by reducing the voltage at pin1. This is also called X-Ray protection. R137 set the protection point.

Pin 8 of FBT sense the beam current. When beam current rise, base voltage of Q126 drop and so the emitter does. The voltage across C108 drops to pull down the voltage at pin17 of I501.

When the voltage at pin 17 of I501 drops under 6V, contrast of display start to decrease. R167 set the light output where the contrast (or full white screen light output) start to drop. If the beam current is too high, Q118 will conduct and shutdown PWM controller (I101).

Pin 7 of FBT provide negative bias for Grid 1 of CDT:

Pin5 of I310 provide vertical blanking to base of Q108 via D113. Q108 collector pulse drops 63V to give a proper blanking level at Grid 1 of CDT. When monitor turns off, pin3 (HUNLOCK) is pull high to turn off Q108 via D108. Grid 1 of CDT is then pulled down to most negative voltage from pin7 of FBT to protect CDT. This action is so-called spot killer.

8-5 Dynamic focus circuit

The vertical dynamic focus is from pin 32 of I301 and feed to base of Q105 via R105 and C103. The horizontal dynamic focus is taken between L402 and Horizontal S correction capacitors. It is step up (amplified) to the certain level voltage (600V approx. at 94kHz Timing Mode) and combine with Vertical dynamic focus waveform through L403, and then feed to PIN 11 of FBT. The dual trace parabola wave-form plus the DC focus voltage gives sharp and clear display for the whole screen.

The two variable resistors on top of FBT provide focus setting.

The bottom one set Grid 2 voltage of CDT.

8-6 Video and CDT drive circuit

8-6-1 VIDEO PREAMPLIFIER (I501)

The signals come from PC through P901 to CDT drive board (PWB-0237). Pin7 (Red), pin5 (Green), pin3(Blue) feed to pin11, 6,2 of I901(video pre-amplifier). Pin 4, 9, 13 of I901 are OSD R, G, B video signals input coming from OSD IC I503. Pin 12 of I901 is the input for OSD blanking signal which blank the normal video as OSD video signal is active. Since the video inputs are AC coupled to I901, so I901 need a clamping signal (at pin 19) from H. sync (IA01 pin 34) to give DC restoring at I901 outputs. The horizontal blanking signal is provided from PWB-0235. Via P902A, it connects to pin 27 of I901. The video outputs of I901 will have the level darker than the video black level during the horizontal retrace time. Pin 20 and 21 are IIC input for MCU (IA01) to control video. By IIC bus MCU will initiate I901 and control the contrast, brightness, R/G/B gain, and R/G/B bias.

Pin15 is an ABL control input. By detecting the beam current, it will reduce the contrast when the beam current exceeds the setting point.

8-6-2 VIDEO DRIVE AND OUTPUT CIRCUITS

After being pre-amplified, the R. G. B. video signals are output from pin35, pin32, and pin29 of I901 respectively. The amplitude of the signal at these output are about 3 ~ 4 V p-p. Those video signals are connected the I904 at pin 7, 6, 9 respectively.

The I904 is video output amplifier to amplify the R, G, and B signal. They offer about 40 V p-p signal in amplitude to drive the cathodes of CRT.

L912, L942, L972, are the peaking coils, for the compensation of high frequency response.

The DC off-set bias voltage is set up by R902, R903 at pin30 of I901.

The cathode cut-off setting voltages required for white balance are obtained from pin23(r), pin25 (g), pin26 (b) respectively, These output magnitude can control the conduction of transistors Q903, Q933, Q963 individually. The DC bias of the cathodes are then varied to optimize the color temperature of back ground.

Brightness control: Pin 2 of IA01 provides Brightness control. It feed through P903 to base of Q960 to vary R, G, B bias at cathodes simultaneously.

8-7 Convergence circuit

Pin1 of IA01 provides a voltage (0 to 5V) to Q426, Q427, and Q428, then drive the Horizon. convergence coil of deflection yoke through P420..

Pin39 of IA01 provides a voltage (0 to 5V) to Q305, Q306, and Q307, then drive the vertical convergence coil of deflection yoke.

8-8 Purity circuit

PWB-0417 provides purity control on four corners of CDT.

Through IIC bus (pin 27, 28 of IA01), IA01 communicate with I501 on purity board. I501 is a digital to analog converter. There are four controls on corners of CDT. User can adjust the white uniformity and color uniformity at four corners.

9. ADJUSTMENT

The adjustment data with tolerance is only for setting to the optimum performance.

SERVICE ADJUSTMENT LOCATIONS

Main Board (parts side view)---PWB-0404

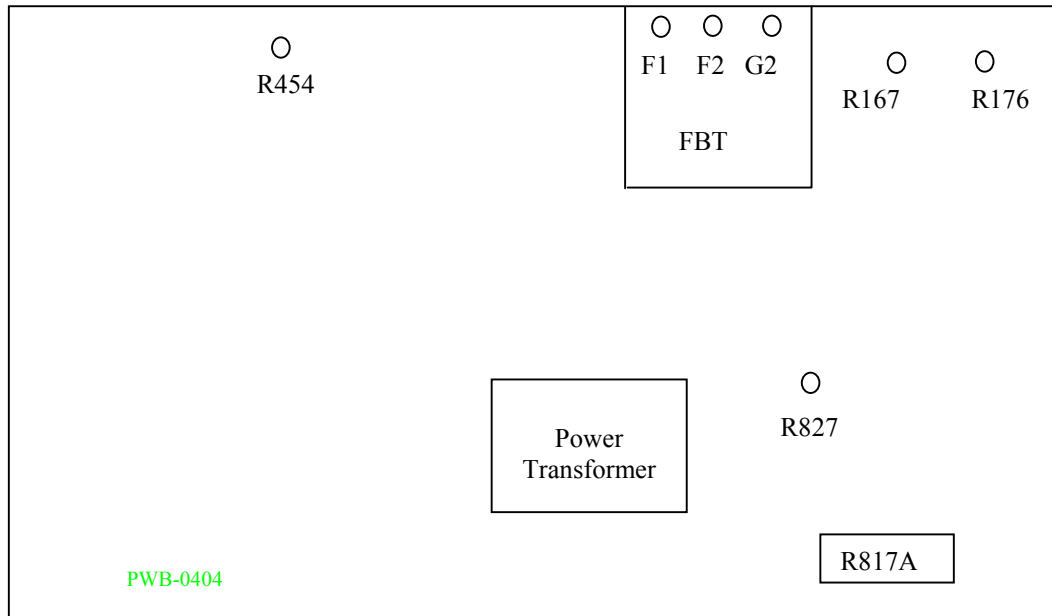

- F1-----Variable Resistor on top of FBT for Static Focus adjust.
- F2-----Variable Resistor on middle of FBT for Dynamic Focus adjust.
- G2-----Variable resistor on bottom of FBT for Grid 2 set up.
- R167----Full white brightness adjust.
- R176----High voltage setting
- R454----Raster center
- R827----B+ = 81V setting
- R817A---Set power supply working frequency
- Degauss-----To degauss function
- Enter key-----Enter OSD key
- Down key-----Decrease adjust value or counterclockwise select Icon
- Up key-----Increase adjust value or clockwise select Icon
- Auto -size key-----Auto sizing

9-1 B+ (81V) output voltage adjustment

- a). Apply PC signal with any pattern to the monitor.
- b). Connect AC input and power on the monitor.
- c). Brightness at center, contrast at maximum.
- d). Adjust R827 for the voltage at heat-sink of D816 to 81V

9-2 High voltage

- Apply PC signal with 31.47kHz / 60Hz(640 x 480) Mode and full white pattern to the monitor.
- Connect AC input and power on the monitor.
- Brightness at center, contrast at maximum.
- Adjust R176 for Normal high voltage = 26.2kV



9-3 Full brightness setting (Timing Mode 91kHz /85Hz 1280 x 1024 mode)





- Apply Chroma 2250 pattern generator or PC signals with full white pattern to the monitor.
- Connect AC input and power on the monitor.
- Brightness at center, contrast at maximum.
- Adjust proper Horizontal and vertical size.
- Set R, G, B bias and Gain (follow color temp. adjustment procedure)
- Adjust R167 to get 30FL. +/- 1FL

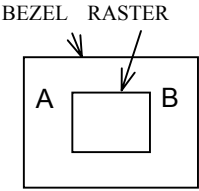



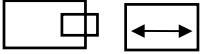
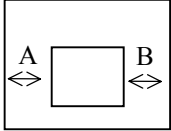

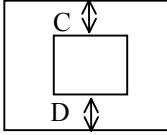
9-4 OSD Adjustment (See the table below)(Enter OSD Menu) : Turn on the monitor by pressing power



switch and OSD on/off key at the same time, release power switch and continue to press enter key, then release the enter key until display appears.

Note: For autosizing function, each preset mode adjustment must be stored into MCU by pressing the “Head” Icon on preset OSD menu.

Item	Adjustment Description	SPEC.
(1) Horizontal Raster Center	<ul style="list-style-type: none"> * Mode : Mode 11 (1600x 1280 @85Hz) * Pattern : Black (Background) * Brightness : Raster visible * Adjust R454 for raster position 	 <p style="text-align: center;"> A-B =0.5—1mm</p>
(2) Vert. Linearity C Correction Adjustment S Correction Adjustment	<ul style="list-style-type: none"> * Mode : Mode 9(1024 x 768 @ 85Hz) * Pattern : 8 x 6 Crosshatch * Brightness : Center * Contrast : Max * Open OSD , enter “FS” and select “LB” Adjust until square height of top is equal to bottom * Open OSD, enter “” and select  “ ” Adjust until square height of top and bottom are equal to center. 	$\frac{Y_{\max} - Y_{\min}}{Y_{\max} + Y_{\min}} \leq 4\%$

Item	Adjustment Description	SPEC.
(3)Horizontal. Width Adj. (Every Mode) 	*Pattern: Crosshatch *Brightness: Center. Contrast: Max. *Enter Pre-set Mode *Select Horizontal Width Icon. *Press UP/DOWN to get 353mm	353 ±3 mm (Every Mode)
(4)Horizontal Phase Adj. (Every Mode)	*Pattern: Crosshatch *Brightness: Center. Contrast: Max. *Select Horizontal Phase Icon. * Press UP/DOWN to center display.	 A-B ≤ 2mm (Every Mode)
(5) Vertical Height Adj. (Every Mode) 	*Pattern: Crosshatch *Brightness: Center. Contrast: Max. *Select Vertical Height Icon. *Press UP/DOWN to obtain 264mm	264±3mm (Every Mode)
(6) Vertical center Adj. (Every Mode) 	*Pattern: Crosshatch *Brightness: Center. Contrast: Max. *Select Vertical Center Icon. * Press UP/DOWN to center display.	 C-D ≤ 2 mm (Every Mode)
(7) Rotation Adj. 	*Pattern: Crosshatch *Brightness: Center. Contrast: Max. *Select Rotation Icon. * Press UP/DOWN to rotate the display to the best..	Only adjust Mode 9
(8) Geometric Adj. (a)Pin-balance. (Every Mode) 	*Pattern: Crosshatch *Brightness: Center. Contrast: Max. *Pin-balance Adj.: Select Pin-balance Icon Press UP OR DOWN Key to correct the Bow distortion to the best.	Right & Left≤2.0mm Top & Bottom≤2.0mm Barrel≤1.5mm Using window Horizontal.: Within 2.0mm window Vertical.: Within 2.0mm window (Every Mode)

Item	Adjustment Description	SPEC.
(b)Parallelogram (Every Mode) 	*Parallelogram Adj.: Select Parallelogram Icon Press UP OR DOWN Key. to correct the Orthogonality to the best.	Pin distortion < 1.0mm Left / right < 1.5mm < 0.5mm in 50 mm LINE
(c)Pincushion Adj. (Every Mode) 	*Pincushion Adj.: Select Pincushion Icon Press UP OR DOWN Key, to straighten Side Pincushion.	
(d)Trapezium Adj. (Every Mode)  	*Trapezium Adj.: Select Keystone Icon Press UP OR DOWN Key, to make picture geometric distortion the best.	
(e)Pin-corner Adj. (Mode 11) 	*Pin-corner Adjustment: Select Pin-corner Icon Press UP OR DOWN Key, to make picture geometric distortion the best. (Note this Adj. Item is used to correct the four corners in a small quantity)	
(9).Contrast 	*Standard pre-set setting is Contrast adjust to the maximum.	NC
(10)Color Temperature. Adjustment		

Item	Adjustment Description	SPEC.
<p data-bbox="236 237 437 304"><a>.9300°K bias Adj.</p>	<p data-bbox="491 237 983 427">*Enter preset OSD menu. *Mode 9: 1280 x 1024 Pattern : 11(Black pattern) *Brightness : set at 107.. Contrast : Max.. *Select color Adj. Icon.</p> <div data-bbox="871 427 970 510" style="text-align: center;">  </div> <p data-bbox="499 477 1038 786">Select 9300°K first. The R,G,B bias initial setting should be in the 160 DAC value. Adj the screen VR on FBT to get 0.7+/-0.1FL *Adj. R,G,B bias until x = 0.283+/- 0.006 y = 0.297+/-0.006 Y =0.7 +/- 0.1 Ft/L</p>	<p data-bbox="1158 412 1347 517">x=0.283+/-0,01 y=0.297+/-0.01 Y=0.7+/-0.1Ft/L</p>
<p data-bbox="236 824 437 931">.6500°K bias 5000°K bias ADJ</p>	<p data-bbox="491 824 983 1014">*Enter preset OSD menu. *Mode 9 : 1280 x 1024 Pattern : 11(Black pattern) * Brightness: set at 107.. Contrast : Max.. *Select color Adj. Icon.</p> <div data-bbox="871 981 970 1064" style="text-align: center;">  </div> <p data-bbox="499 1025 1038 1335">Select 5000°K , 6500°K first The R,G,B bias initial setting should be in the 160. *Adj. R,G,B bias until x =0.313+/-0.006 y =0.329+/-0.006 (6500°K) Y =0.7 +/- 0.1Ft/L x =0.346+/-0.006 y=0.359+/-0.006(5000°K) Y =0.7 +/- 0.1Ft/L</p>	<p data-bbox="1230 1066 1273 1093">NC</p>
<p data-bbox="220 1350 405 1377">(11).Brightness</p> <div data-bbox="272 1395 360 1491" style="text-align: center;">  </div>	<p data-bbox="491 1350 1038 1574">*Color temperature bias shall be adjusted. *Enter preset OSD menu. *Adjust brightness down to 0.06+/-0.01FL. *Power off Monitor , then power on again to check Brightness should be at 50% in User's OSD menu.</p>	<p data-bbox="1230 1615 1273 1641">NC</p>

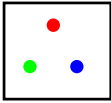
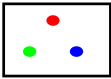
<p><c>.9300°K Gain Adj.</p>	<p>*Enter preset OSD menu *Mode 9 : 1280 x 1024 *Pattern : 70mm x 70mm White block. *Brightness : 0.06FL(background) *Contrast : Max.. *Select color Adj. Icon.  *Select 9300°K firstly *Disable R,B signal; only Green signal left. *Adjust Green Gain to get 28FL around *Adj. R,B Gain until x=0.283+/-0.006 y=0.297+/-0.006 Y = 37 to 42FL</p>	<p>x =0.283 ±0.01 y =0.297 ±0.01 Y > = 38 Ft/L</p>
<p><d>.6500°K Gain 5000°K Gain ADJ</p>	<p>*Enter preset OSD menu *Mode 9: 1280 x 1024 *Pattern : 70mm x 70mm White block. *Brightness : 0.06FL, Contrast : Max. *Select color Adj. Icon.  *Select 6550°K *Disable R,B signal; only Green signal left. *Adjust Green Gain to get 28FL around *Adj. R,B Gain until x =0.313+/-0.015 ,y =0.329 +/-0.015(6500°K) x =0.346+/-0.015 ,y =0.359 +/-0.015(5000°K) Y = 33 to 38FL</p>	<p>x =0.313+/-0.01 y =0.329+/-0.01 x=0.346+/-0.01 y =0.359+/-0.01 Y = 33 to 38FL</p>
<p>(12) ABL setup</p>	<p>*Mode 9 : 1280 x 1024 *Brightness: 0.06FL Contrast: Max. *Pattern : Pattern 41 (Full white) *Adjust VR(R167) to get 30± 1Ft/L</p>	<p>30± 2Ft/L</p>
<p>(13).Focus adjustment</p>	<p>*Mode 9 : 1280 x 1024 *Pattern : Compaq me Pattern. Compaq me Pattern. reverse. *Brightness: 0.06FL. Contrast: Max. *Adj. Focus VRS on FBT until full screen focus to the best.</p>	<p>Both pattern” me “ and its’ reverse Pattern to be most distinguished.</p>
<p>(14).Convergence adjustment</p>	<p>*Mode 9 : 1280 x 1024 *Pattern: Crosshatch pattern *Brightness :center Contrast : 30Ft/L *4 & 6 Pole magnet adjusted to get optimized convergence, the criteria is: A circle with 264 mm diameter Area: < or = 0.3mm Remaining area: < or = 0.4mm</p>	<p>Circle :<=0.30 mm Rectangle :<=0.40 mm</p>
<p>(15) Vertival focus setting</p>	<p>Normally this setting is at 65</p>	

(16) H Moire setting	Normally set at 30 for resolution 1280 x 1024 mode (mode 8 and 9) And zero for all other modes	
(17) V. Moire setting	Normally set at zero for all modes	

10. TROUBLESHOOTING FLOW CHART

SECTION 1 Q811 on, Q812 off

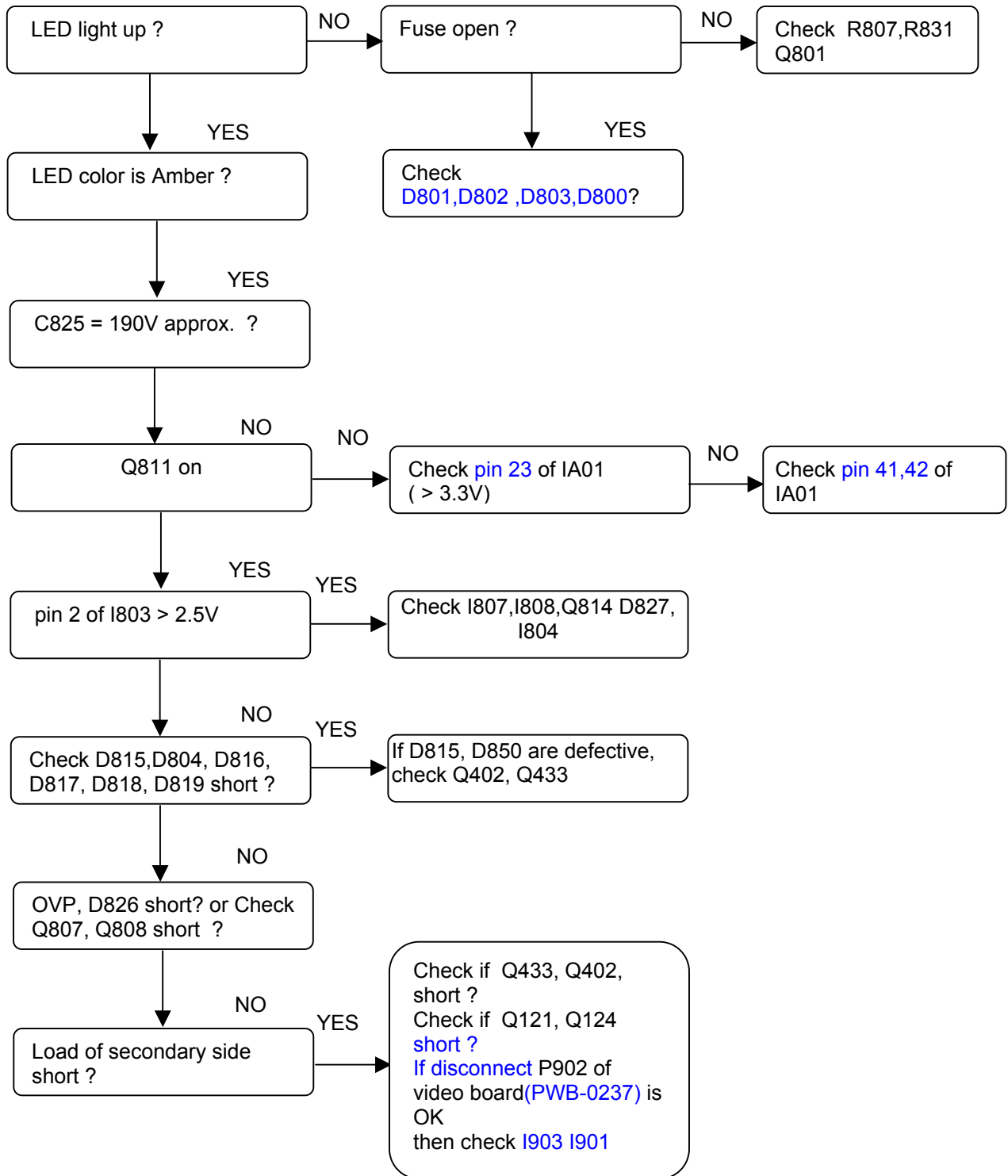

SECTION 2

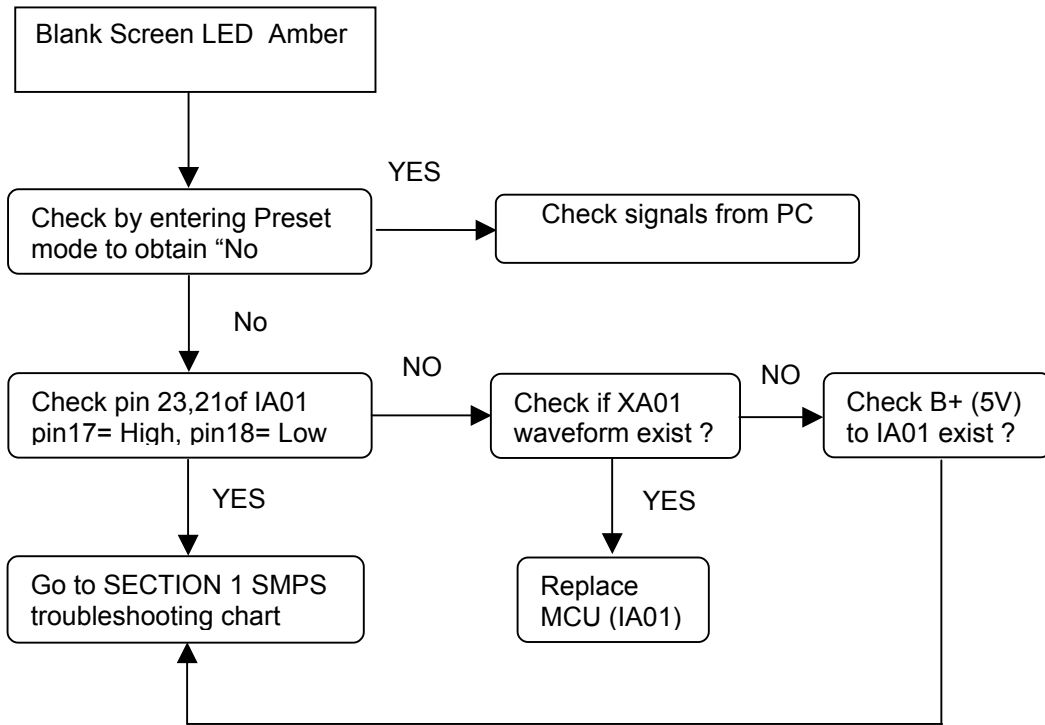

SECTION 3

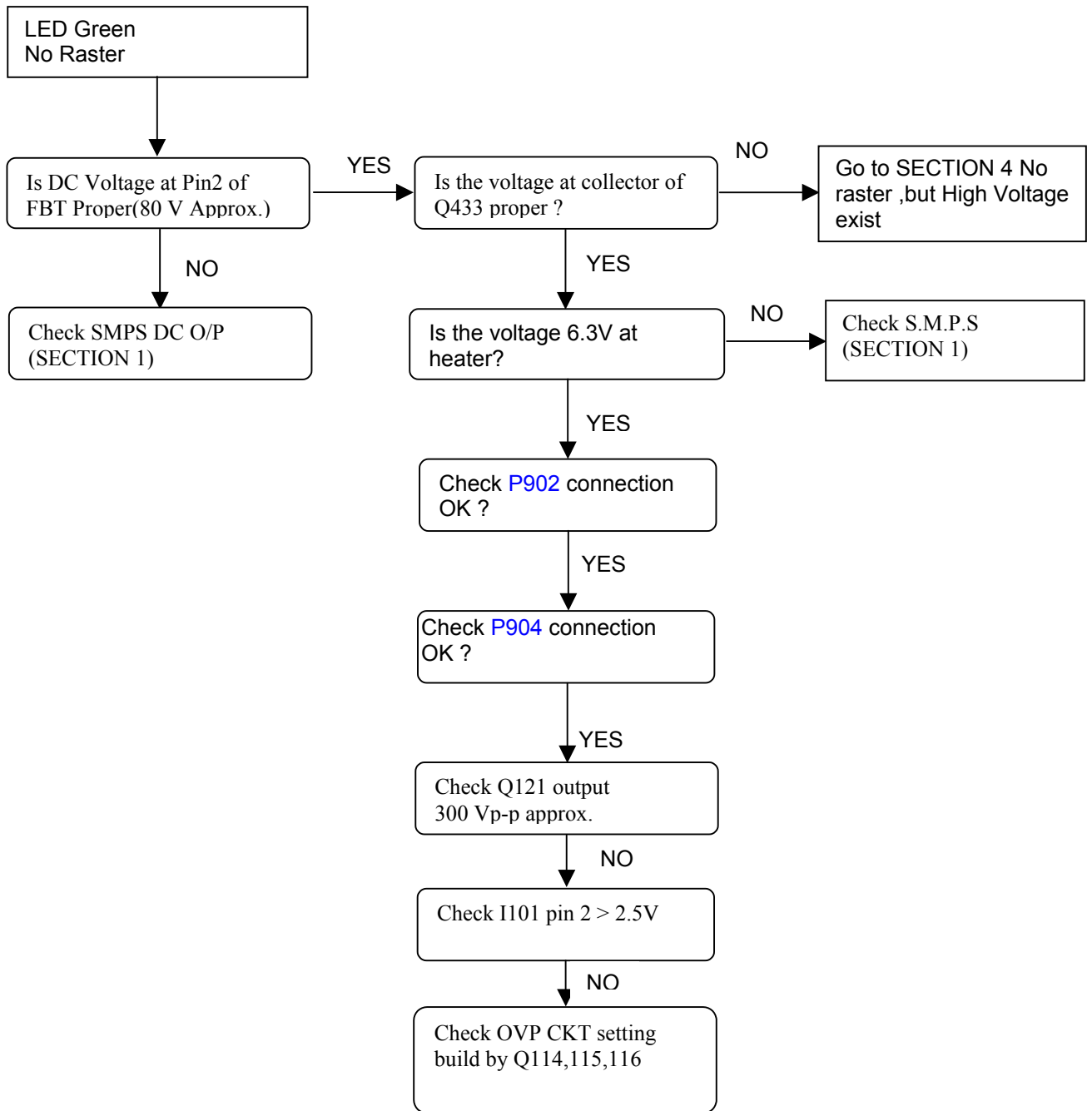

SECTION 4

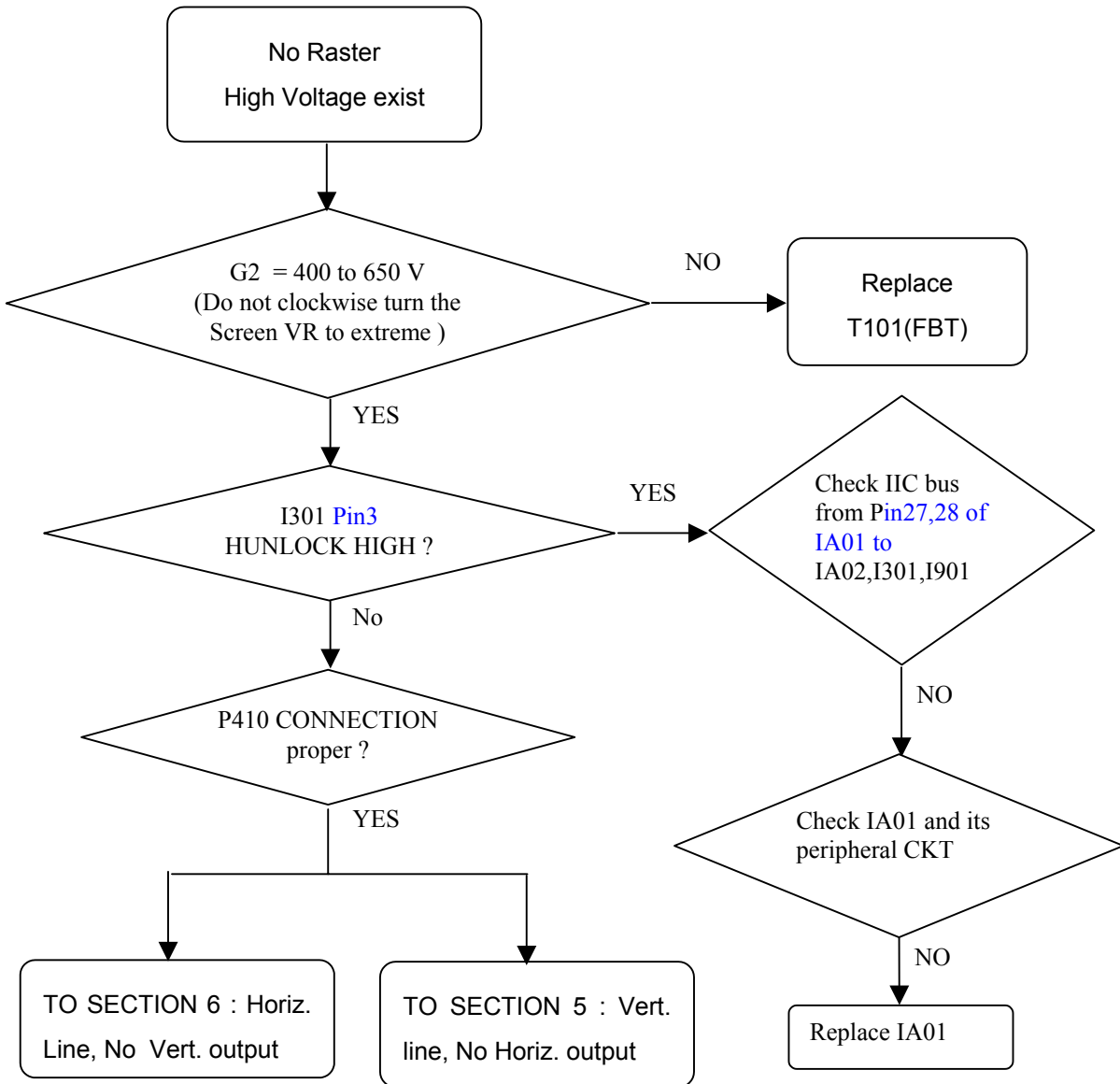

SECTION 5

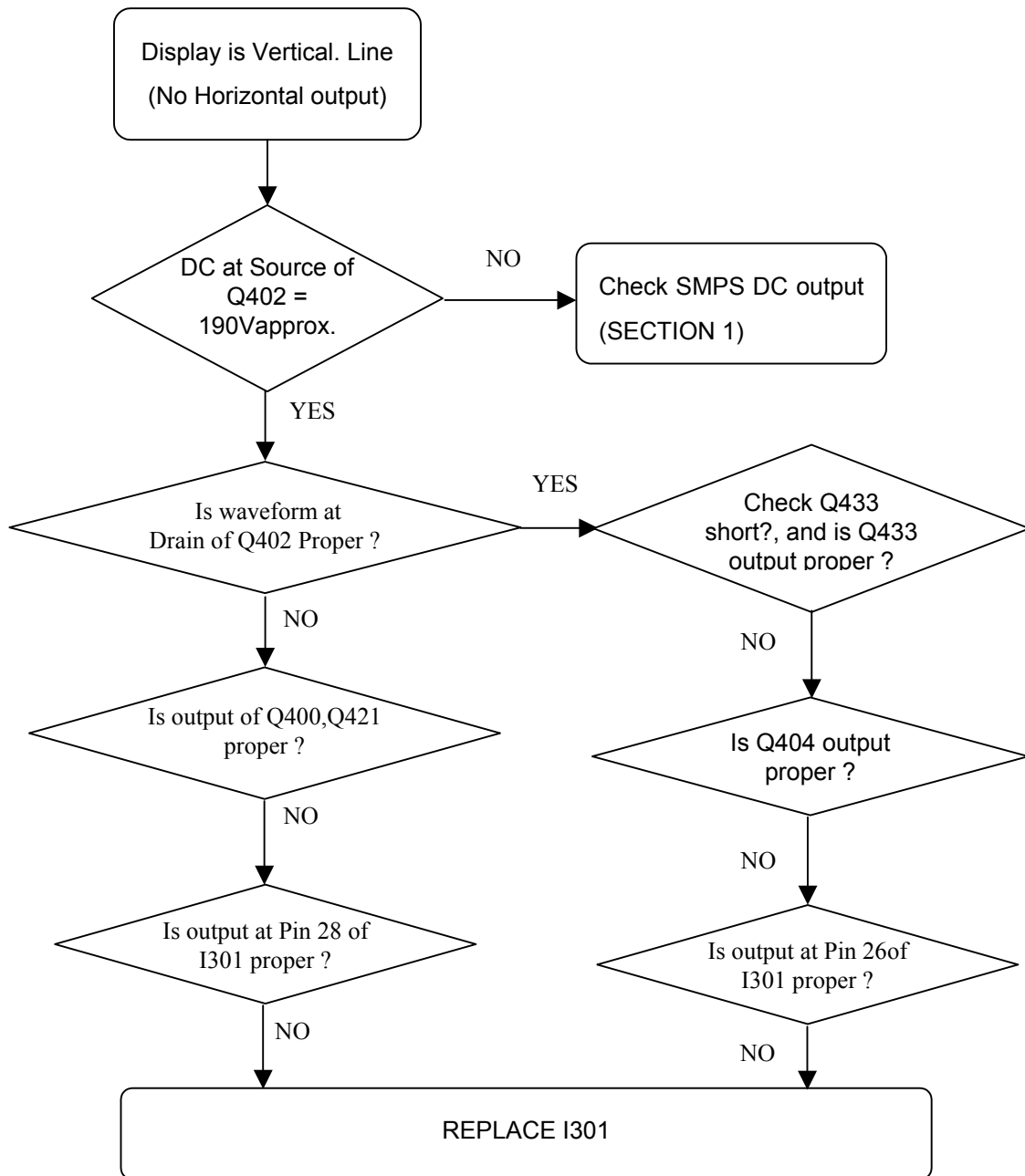

SECTION 6

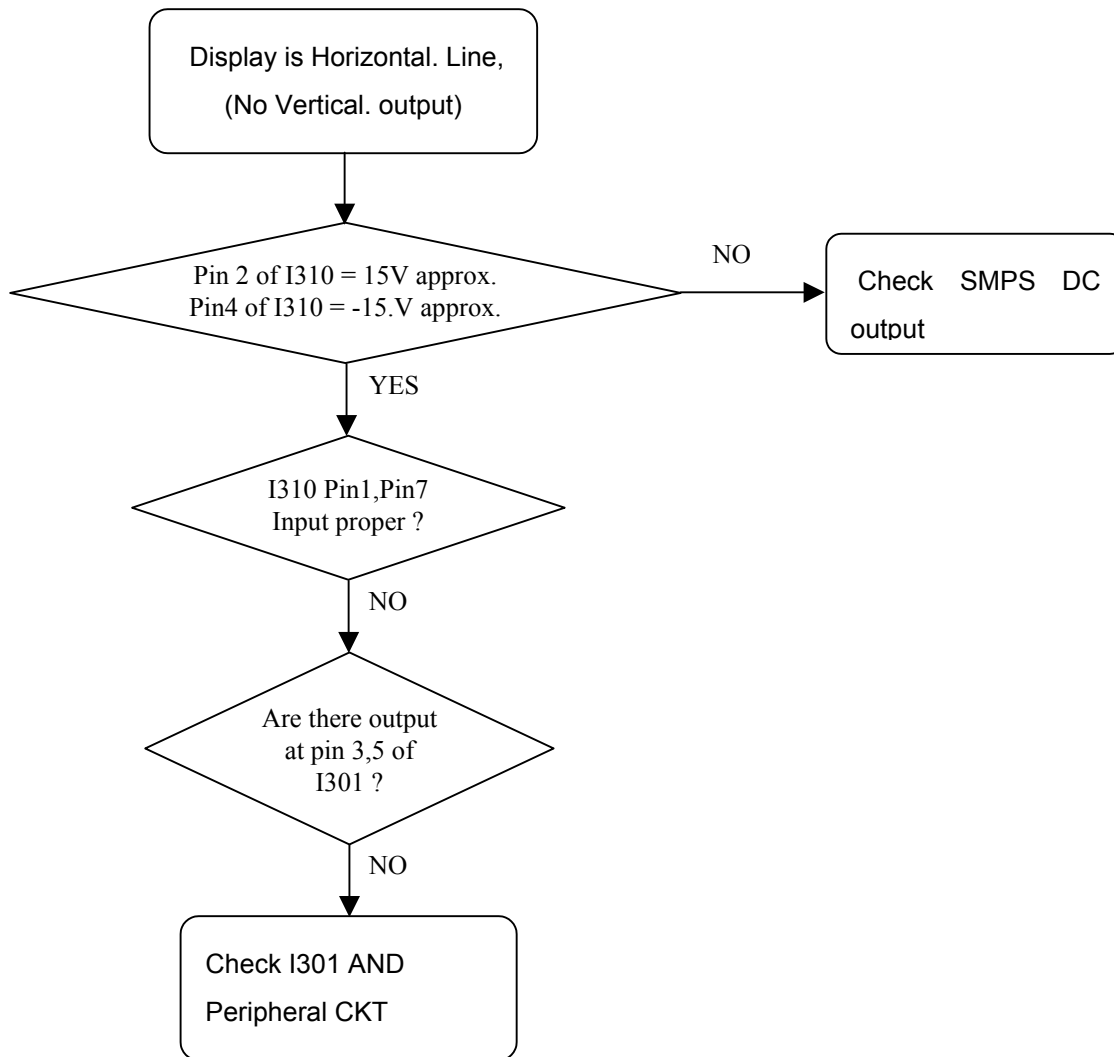

SECTION 7

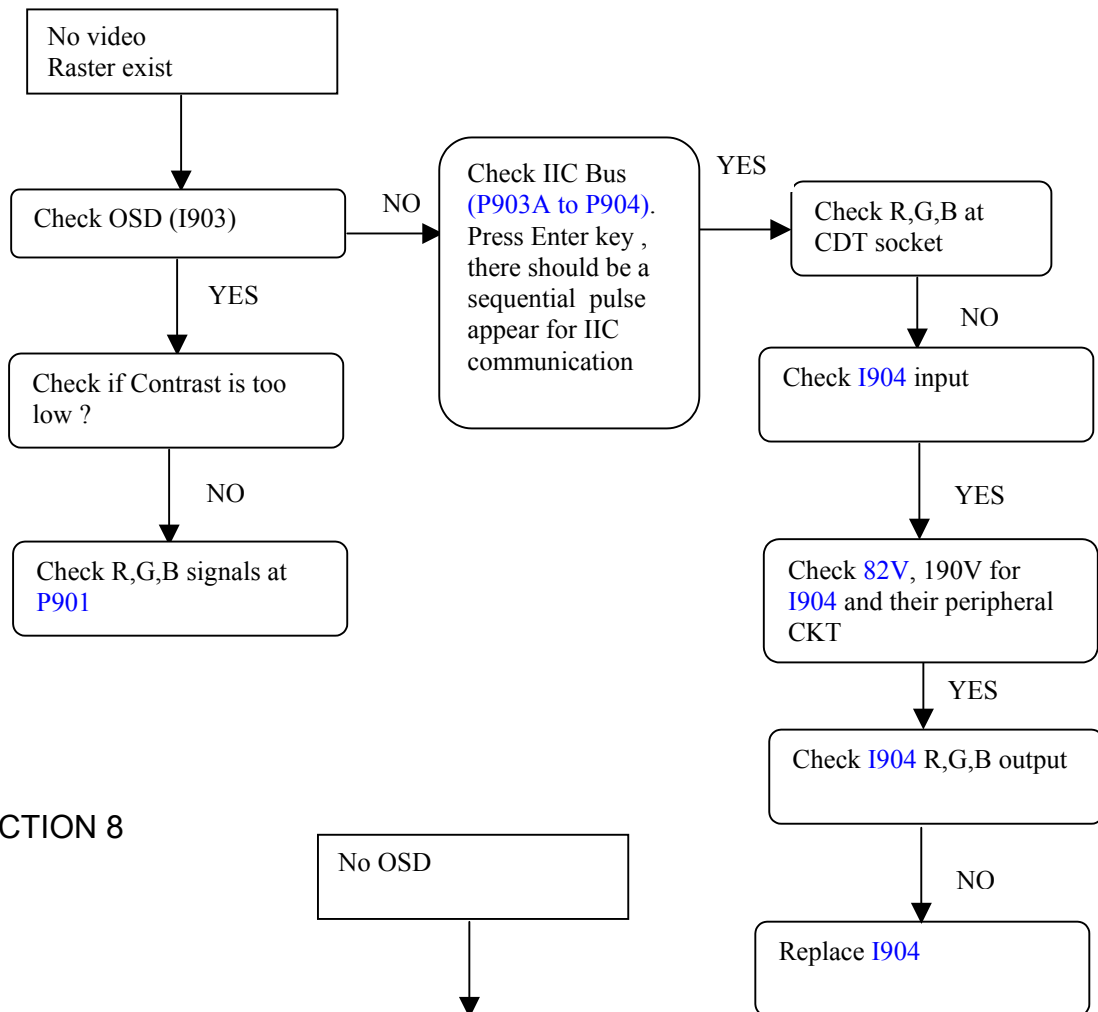

SECTION 8

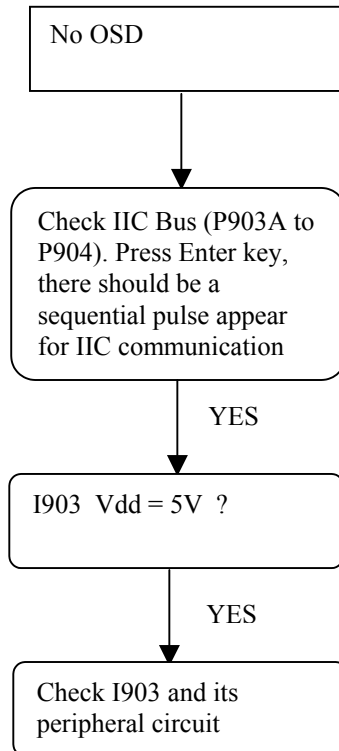

11. REPLACEMENT PARTS LIST

WARNING: Replacement parts that have special characteristics important to safety should be replaced only with types identical to those in the original circuit or specified in the parts list. Before replacing any of these components, read carefully the product safety precautions. Do not degrade the safety of the display through improper servicing

ABBREVIATIONS:

RESISTOR

PART NAME & DESCRIPTION			
TYPE		ALLOWANCE	
R	Resistor	F	±1%
CF	Carbon Film	G	±2%
CC	Carbon Composition	J	±5%
MOF	Metal Oxide Film	K	±10
FU	Fusible	M	±20
MF	Metal Film		
VR	Variable Resistor		
CR	Cement Resistor		
SMD	Thick Film Chip 1206		

CAPACITOR

PART NAME & DESCRIPTION			
TYPE		ALLOWANCE	
C	Capacitor	F	±1%
CE	Ceramic	G	±2%
EL	Electrolytic	J	±5%
PO	Polyester	K	±10%
TA	Tantalum	M	±20%
PP	Polypropylene	P	±100%–0%
ME	Metalized	Z	±80%–20%
BL	Barrier Layer		
SMD	Monolithic SMD 0805		

ASSEMBLY PCB-MAIN (PWB-0334A) CAPACITOR

CKT NO.	Part no.	Description
C100	5248439091	C. CE 2KV 39P J
C101	5234333191	C. CE 2KV 330PF K
C102	5223622201	CQ93T630V 2200PF J
C103	5213610091	C. EL 50V 1UF M
C104	5214701091	C. EL 450V 1UF M
C105	5275122491	C. ME 63V 0.22MF J
C106	5276110491	C. ME 100V 0.1UF J
C107	5205647991	C. EL 50V 4.7UF M
C108	5213601091	C. EL 50V 1UF M
C109	5236310491	C. BL 50V 0.1UF Z
C110	5231310291	C. CE 50V 1000PF K
C111	5275122491	C. ME 63V 0.22UF J
C112	5221122391	C. PO 50V 22000PF J
C114	5271133391	C. ME 100V 33000PF J
C115	5276110491	C. ME 100V 0.1UF J
C116	5213622091	C. EL 50V 22UF M

CKT NO	Part no.	Description
C117	5227322291	C. ME 100V 2200PF J
C118	5214019612	100V 330UF
C120	5213639091	C. EL 50V 22UF M
C121	5236310491	C. BL 50V 0.1UF Z
C122	5213601091	C. EL 50V 1UF M
C123	5233310291	C. CE 1KV 1000PF K
C126	5232322291	C. CE 500V 2200PF K
C127	5232310291	C. CE 500V 1000LF K
C128	5223510201	C. PO 400V 1000PF K
C129	5213447091	C. EL 25V 47UF M
C130	5271110501	C. ME 100V 1UF J 35KHz
C131	5233310291	C. CE 1KV 1000PF K
C132	5223447301	C. PO250V 47000PF J5KHz
C133	5236310491	C. BL 50V 0.1UF Z
C134	5213610091	C. EL 50V 10UF M
C135	5214433012	C. EL 250V 33UF M

P90f-1

CKT NO.	Part no.	Description	CKT NO.	Part no.	Description
C136	5213622091	C. EL 50V 22UF M	C391	5275122191	C. ME 63V 0.22UF J
C137	5271147401	C. ME 100V 0.47UF J	C400	5223433301	C. PO 250V 33000PF J
C139	5214019612	C. EL 100V 330UF M	C401	5213447091	C. EL 25V 47UF M
C301	5276110491	C. ME 100V 0.1UF J	C401A	5236310491	C. BL 50V 0.1UF Z
C302	5221168291	C. PO 50V 6800PF J	C402	55206410112	C. EL 250V 100UF M
C303	5247082191	C. CE 50V 820PF J	C402A	5232310301	C. CE 500V 10000PF K
C304	5275115391	C. ME 63V 15000PF J	C403	5223422301	C. PO 250V 22000PF J
C305	5213647991	C. EL 50V 4.7UF M	C403A	5233318191	C. CE 1KV 180PF K
C306	5213601091	C. EL 50V 1UF M	C404	5223622201	C. PO 630V 2200PF J
C307	5247082191	C. CE 50V 820PF J	C405	5248468091	C. CE 2KV 68PF J
C308	5227518291	C. PO 100V 1800PF G	C406	5223749200	C. PO 1600V 4900PF J
C309	5247022191	C. CE 50V 220PF J	C406A	5061105400	BEAD CORE BRH5X4X1.5
C310	5275147491	C. ME 63V 0.47MF J	C406E	5056208100	EYELET 1.6X3
C311	5247039091	C. CE 50V 39PF J	C407	5275147491	C. ME 63V 0.47UF J
C312	5275122491	C. ME 63V 0.22MF J	C409	5234347201	B DC 2KV 4700PF J
C313	5213447091	C. EL 25V 47UF M	C410	5213610091	C. EL 50V 10UF M
C313A	5242212191	C. CE 50V 120PF J	C411	5234547201	C. CE 2KV 4700PF M
C314	5242212191	C. CE 50V 120PF J	C411A	5232310291	C. CE 500V 1000PF K
C315	5247010191	C. CE 50V 100PF J	C412	5233002691	C. CE 2KV 470PF K 105°C
C316	5247010191	C. CE 50V 100PF J	C413	5214222991	C. EL 160V 2.2UF M
C317	5213447091	C. EL 25V 47UF M	C414	5214401091	C. EL 250V 1.00UF M
C318	5213322191	C. EL 16V 220UF M	C415	5214019512	C. EL 25V 1000UF M
C319	5232310291	C. CE 500V 1000PF K	C416	5270211501	MPA 400V 0.15UF J
C319A	5232310291	C. CE 500V 1000PF K	C417	5223410301	CQ93T 250V 10000PF J
C320	5275110491	C. ME 63V 0.1MF J	C419	5270424402	CF93T 400V 0.24UF J
C321	5275110491	C. ME 63V 0.1MF J	C420	5270351401	CF93T 400V 0.51UF J
C322	5232310291	C. CE 500V1000PF K	C421	5270468301	CF93T 400V 68000PF J
C324	5213647991	C. EL 50V 4.7UF M	C422	5213410191	C. EL 25V 100UF M
C325	5213601091	C. EL 50V 1.0UF M	C423	5270207701	C. ME 400V 0.1UF J
C382	5213310191	C. EL 16V 100UF M	C424	5213647991	C. EL 50V 4.7UF
C382A	5213622091	C. EL 50V 22UF M	C425	5270314502	CF93T 250V 1.4UF
C383	5222433291	C. PO 100V 3300PF J	C426	5270211401	MPA 250V 0.1UF
C384	5236310491	C. BL 50V 0.1UF Z	C454	5214422991	C. EL 250V 2.2UF M
C385	5213310212	C. EL 16V 1000UF M	C455	5214422991	C. EL 250V 2.2UF M
C386	5213310212	C. EL 16V 1000UF M	C471	5213310191	C. EL 16V 100UF M
C386A	5236310491	C. BL 50V 0.1UF Z	C801	5214110091	C. EL 100V 10UF M
C387	5277127401	C. ME 100V 0.27MF J	C802	5230105501	C. CE 250Vac 4700PF M
C388	5213610191	C. EL 50V 100UF M	C802A	5230105401	C. CE 400Vac 2200PF M
C390	5233315191	C. CE 1KV 150PF K	C803	5230105501	C. CE 250Vac 4700PF M

CKT NO.	Part No.	Description	CKT NO	Part No.	Description
C803A	5230105401	C. CE 400Vac 2200PF M	C848	5233318191	C. CE 1KV 180PF K
C804	5270112601	C. ME 275Vac 0.22UF K	C849	5213633091	C. EL 50V 33UF M
C804A	5270111091	C. ME 275Vac 0.1UF K	C850	5230105501	C. CE AC250Vac 4700PF M
C805	5232310301	C. CE 500V1000PF K	C851	5230105501	C. CE AC250Vac 4700PF M
C806	5232310301	C. CE 500V1000PF K	C852	5213510213	C. EL 35V 1000UF M
C809	5210313900	C. EL 400V 330UF M	C853	5233315191	C. CE 1KV 150PF K
C809E	5056208101	C. EYELET 2.4X3	C860	5223522301	CQ93T 400V 0.022UF
C811	5213622091	C. EL 50V 22UF M	C870	5216410001	C. EL 250V 10UF M
C812	5213622091	C. EL 50V 22UF M	C870A	5233310291	C. CE 1KV 10000PF M
C813	5223622201	C. PO 630V 2200UF J	C872	5214005001	C. EL 25V 470UF M
C814	5213622091	C. EL 50V 22UF M	C872A	5214005001	C. EL 25V 470UF M
C815	5213410191	C. EL 25V 100UF M	C875	5213310191	C. EL 16V 100UF M
C816	5213610091	C. EL 50V 10UF M	C875A	5231310291	C. CE 50V 1000PF K
C817	5214122091	C. EL 100V 22UF M	C876	5213310212	C. EL 16V 1000UF M
C818	5231322291	C. CE 50V 2200UF K	C881A	5234318191	C. CE 2KV 180PF K
C819	5221122291	C. PO 50V 2200PFJ	C882A	5234327191	C. CE 2KV 270PF K
C820	5275115391	C. ME 63V 15000PF J	C883	5234333101	C. CE 2KV 330PF K
C821	5213410191	C. EL 25V 100UF M	C886	5276110491	C. ME 100V 0.1UF J
C822	5213622091	C. EL 50V 22UF M	C886A	5232310301	C. CE 500V 10000PF K
C823	5236310491	C. BL 50V 0.1UF Z	C887	5214122091	C. EL 100V 22UF M
C824	5233310191	C. CE 1KV 100PF K	CA01	5213347091	C. EL 16V 47UF M
C825	5216410101	C. EL 250V 100UF M	CA02	5242210091	C. CE 50V 10PF J
C826	5233318191	C. CE 1KV 180PF K	CA03	5242210091	C. CE 50V 10PF J
C827	5214019812	C. EL 100V 220UF M	CA04	5242212191	C. CE 50V 120PF J
C828	5213647091	C. EL 50V 47UF M	CA05	5242212191	C. CE 50V 120PF J
C829	5213410212	C. EL 25V 1000UF M	CA06	5242212191	C. CE 50V 120PF J
C830	5233318191	C. CE 1KV 180PF K	CA07	5213622991	C. EL 50V 2.2UF M
C831	5205347112	C. EL 16V 470UF M	CA08	5213647991	C. EL 50V 4.7UF M
C832	5234310101	C. CE 2KV 100PF K	CA09	5213647991	C. EL 50V 4.7UF M
C833	5214019791	C. EL 25V 330UF M	CA10	5213247191	C. EL 10V 470UF M
C833A	5213610091	C. EL 50V 10UF M	CA12	5231310291	C. CE 50V 1000PF K
C834	5271133391	C. ME 100V 33000PF J	CA13	5231333191	C. CE 50V 330PF K
C835	5233318191	C. CE 1KV 180PF K	CA14	5213622991	C. EL 50V 2.2UF M
C836	5213310212	C. EL 16V 1000UF M	CA15	5213647991	C. EL 50V 4.7UF M
C838	5213447091	C. EL 25V 47UF M	CA16	5213610091	C. EL 50V 10UF M
C840	5213222191	C. EL 10V 220UF M	CA17	5242210191	C. CE 50V 100PF J
C841	5213310212	C. EL 16V 1000UF M	CA18	5242210191	C. CE 50V 100PF J
C844	5205622091	C. EL 50V 22UF M	CA20	5232310291	C. CE 500V 1000PF K
C845	5213447091	C. EL 25V 47UF M	CA22	5242210191	C. CE 50V 100PF J

CKT NO.	Part no.	Description	CA26	5242210191	C. CE 50V 100PF J
CA25	5242210191	C. CE 50V 100PF J	CA27	5231310291	C. CE 50V 1000PF K

SEMICONDUCTOR

DIODE

CKT NO.	Part no.	Description
D101	6611032640	DIODE DIODE RECTIFIER BYV26DGP 800V 1A
D102	6615005836	DIODE ZENER HZ12A2-TD
D103	6611012849	DIODE RECTIFIER RGP10M
D104*	6613003032	DIODE SWITCHING 1N4148-TD 75V 150mA (RA, RB, RC)
D105*	6613003032	DIODE SWITCHING 1N4148-TD 75V 150mA (RA, RB, RC)
D108*	6613003032	DIODE SWITCHING 1N4148-TD 75V 150mA (RA, RB, RC)
D109*	6613003032	DIODE SWITCHING 1N4148-TD 75V 150mA (RA, RB, RC)
D110 (RA)	6615021430	DIODE ZENER BZX79C51
D110 (RB)	6615015640	DIODE ZENER IN5262B
D110 (RC)	6615021441	DIODE ZENER IN5262B-RL
D110A (CB)	6615005836	DIODE ZENER HZ12A2-TD
D110A (CB)	6615023331	DIODE ZENER HZ24-2-TD 23.6-24.7V
D111	6615012530	DIODE ZENER HZ4A2-TD 3.5-3.7V 5mA 0.5w
D112*	6613003032	DIODE SWITCHING 1N4148-TD 75V 150mA (RA, RB, RC)
D113*	6613003032	DIODE SWITCHING 1N4148-TD 75V 150mA (RA, RB, RC)
D114 (RA)	6613002244	DIODE SWITCHING RGP10D-G23
D114 (RB)	6611035644	DIODE SWITCHING RGP10D
D115 (RA)	6613002244	DIODE SWITCHING RGP10D-G23
D115 (RB)	6611035644	DIODE SWITCHING RGP10D
D116*	6613003032	DIODE SWITCHING 1N4148-TD 75V 150mA (RA, RB, RC)
D118 (RA)	6615009752	DIODE ZENER RD6.8B2-T7
D118 (RB)	6615007234	DIODE ZENER HZ7B1-TD 6.7-7V
D119*	6613003032	DIODE SWITCHING 1N4148-TD 75V 150mA (RA, RB, RC)
D120*	6613003032	DIODE SWITCHING 1N4148-TD 75V 150mA (RA, RB, RC)
D125*	6613003032	DIODE SWITCHING 1N4148-TD 75V 150mA (RA, RB, RC)
D126 (RA)	6611018200	DIODE RECTIFIER 30DF2
D126 (RB)	6611015245	DIODE RECTIFIER GUF30D
D127	6611035643	DIODE SWITCHING RGP10G
D128	6611019241	DIODE RECTIFIER BYD73G
D301	6615007834	DIODE ZENER HZ5C1-TD 4.9-5.1V
D310#	6611007240	DIODE RECTIFIER 1N4002RL(RA, RB, RC, RD)
D401*	6613003032	DIODE SWITCHING 1N4148-TD 75V 150mA (RA, RB, RC)
D402 (RA)	6615009336	DIODE ZENER BZX79C10

CKT NO.	Part no.	Description
D402 (RB)	6615009337	DIODE ZENER HZ11A3-TD
D403	6611029306	DIODE RECTIFIER 3AP6
D404	6611018703	DIODE RECTIFIER BY329X-1500S 1500V 8A
D407*	6613003032	DIODE SWITCHING 1N4148-TD 75V 150mA (RA, RB, RC)
D410	6611070347	DIODE RECTIFIER SR204
D477	6611025643	DIODE SWITCHING RGP10G
D478	6611025643	DIODE SWITCHING RGP10G
D800 (RA)	6611029554	DIODE RECTIFIER 1N5406-M FORMED
D800 (RB)	6611029555	DIODE RECTIFIER 1N5406-M PREFORMED
D801 (RA)	6611029554	DIODE RECTIFIER 1N5406-M FORMED
D801 (RB)	6611029555	DIODE RECTIFIER 1N5406-M PREFORMED
D802 (RA)	6611029554	DIODE RECTIFIER 1N5406-M FORMED
D802 (RB)	6611029555	DIODE RECTIFIER 1N5406-M PREFORMED
D803 (RA)	6611029554	DIODE RECTIFIER 1N5406-M FORMED
D803 (RB)	6611029555	DIODE RECTIFIER 1N5406-M PREFORMED
D804 (RA)	6611032640	DIODE RECTIFIER FRRD BYV26DGP 800V 1A 75nS
D804 (RB)	6611012835	DIODE RECTIFIER UFRRD 1NU41-TP3
D804 (RC)	6611032644	DIODE RECTIFIER GUF10K
D806 (RA)	6611032640	DIODE RECTIFIER FRRD BYV26DGP 800V 1A 75nS
D806 (RB)	6611012835	DIODE RECTIFIER UFRRD 1NU41-TP3
D806 (RC)	6611032644	DIODE RECTIFIER GUF10K
D807 (RA)	6615011831	DIODE ZENER RD20EB2-T1
D807 (RB)	6615011833	DIODE ZENER HZ20-1-TD
D808*	6613003032	DIODE SWITCHING 1N4148-TD 75V 150mA (RA, RB, RC)
D810*	6613003032	DIODE SWITCHING 1N4148-TD 75V 150mA (RA, RB, RC)
D811	6611070541	DIODE RECTIFIER 1N5817
D812 (RA)	6611032640	DIODE RECTIFIER FRRD BYV26DGP 800V 1A 75nS
D812 (RB)	6611032644	DIODE RECTIFIER GUF10K
D812 (RC)	6611012835	DIODE RECTIFIER UFRRD 1NU41-TP3
D815	6611012835	DIODE RECTIFIER 1NU41-TP3
D816 (RA)	6611032341	DIODE RECTIFIER 2NU41-TPA1
D816 (RB)	6611032244	DIODE RECTIFIER HER308G 1000V/3A
D817 (RA)	6611015244	DIODE RECTIFIER UF5402G
D817 (RB)	6611018200	DIODE RECTIFIER 30DF2
D817 (RC)	6611015245	DIODE RECTIFIER GUF30D
D818 (RA)	6611015244	DIODE RECTIFIER UF5402G
D818 (RB)	6611018200	DIODE RECTIFIER 30DF2
D818 (RC)	6611015245	DIODE RECTIFIER GUF30D
D819 (RA)	6611032641	DIODE RECTIFIER UFRRD 2NU41-TPA1
D819 (RB)	6611032244	DIODE RECTIFIER HER308G

CKT NO.	Part no.	Description
D820 (RB)	6613002248	DIODE SWITCHING 1N4935
D820 (RC)	6611035644	DIODE RECTIFIER RGP10D
D821*	6613003032	DIODE SWITCHING 1N4148-TD 75V 150mA (RA.RB.RC)
D822*	6611007240	DIODE RECTIFIER 1N4002RL(RA.B.RC.RD)
D823 (RA)	6615006443	DIODE ZENER RD6.2EB2-T1 5.99-6.24V
D823 (RB)	6615009756	DIODE ZENER HZ6C2-TD 6-6.3V
D825 (RA)	6613002244	DIODE SWITCHING RGP10D
D825 (RB)	6613002248	DIODE SWITCHING 1N4935
D825 (RC)	6611035644	DIODE RECTIFIER RGP10D
D826 (RA)	6615011333	DIODE ZENER 1N5252B-RL
D826 (RB)	6615023331	DIODE ZENER HZ24-2-TD 23.6~24.7V
D827	6615007834	DIODE ZENER HZ5C1-TD 4.9-5.1
D828 (RA)	6611007242	DIODE RECTIFIER 1N4002 G23
D828 (RB)	6611007240	DIODE RECTIFIER 1N4002RL
D828 (RC)	6611007244	DIODE RECTIFIER 1N4002
D829 (RA)	6615018830	DIODE ZENER RD18EB2-T1
D829 (RB)	6615018834	DIODE ZENER HZ18-1-TD
D833	6615007834	HZ5C1 4.9-5.1
D840*	6613003032	DIODE SWITCHING 1N4148-TD 75V 150mA (RA.RB.RC)
D850	6611012835	DIODE RECTIFIER 1NU41-TP3
D855	6611070541	DIODE RECTIFIER 1N5817
DA01*	6613003032	DIODE SWITCHING 1N4148-TD 75V 150mA (RA.RB.RC)
DA01A*	6613003032	DIODE SWITCHING 1N4148-TD 75V 150mA (RA.RB.RC)
DA02	6615007834	DIODE ZENER HZ5C1-TD 4.9-5.1
DA04*	6613003032	DIODE SWITCHING 1N4148-TD 75V 150mA (RA.RB.RC)
DA05*	6613003032	DIODE SWITCHING 1N4148-TD 75V 150mA (RA.RB.RC)
DA06*	6613003032	DIODE SWITCHING 1N4148-TD 75V 150mA (RA.RB.RC)
DA07*	6613003032	DIODE SWITCHING 1N4148-TD 75V 150mA (RA.RB.RC)
DA08*	6613003032	DIODE SWITCHING 1N4148-TD 75V 150mA (RA.RB.RC)
DA09*	6613003032	DIODE SWITCHING 1N4148-TD 75V 150mA (RA.RB.RC)
DA10*	6613003032	DIODE SWITCHING 1N4148-TD 75V 150mA (RA.RB.RC)
DA11*	6613003032	DIODE SWITCHING 1N4148-TD 75V 150mA (RA.RB.RC)
DA12	5054431539	DIODE ZENER HZ5C1-TD 4.9-5.1
DA15	6618019800	LED HOLDER LAMP CSL-H500YG2HTJ

PS: * 1N4148 : RA 6613003032 RB 6613003037 RC 6613003048

#1N4002 : RA 6611007240 RB 6611007244 RC 6611007243 RD 6611007245

IC

CKT NO.	Part no.	Description
I101 (RA)	6644063111	IC LINER UC3842BN
I101 (RB)	6644063112	IC LINER DBL3842
I301	6644076308	IC LINER DEFLECTION TDA9116 SDIP32
I310	6644076000	IC LINER V-O/P TDA8172 7P
I802	6640003800	IC VOLTAGE REGULATOR LM1117T 5.0
I803 (RA)	6644063111	IC LINER UC3842BN
I803 (RB)	6644063112	IC LINER DBL3842
I804 (RA)	6642002904	IC PHOTO COUPLER TLP721F
I804 (RB)	6642002906	IC PHOTO COUPLER LTV817M
I804 (RC)	6642002909	IC PHOTO COUPLER KP1010H-B
I805 (RA)	6642002904	IC PHOTO COUPLER TLP721F
I805 (RB)	6642002906	IC PHOTO COUPLER LTV817M
I805 (RC)	6642002909	IC PHOTO COUPLER KP1010H-B
I807 (RA)	6642002904	IC PHOTO COUPLER TLP721F
I807 (RB)	6642002906	IC PHOTO COUPLER LTV817M
I807 (RC)	6642002909	IC PHOTO COUPLER KP1010H-B
I808 (RA)	6640007705	IC VOLTAGE REGULATOR ADJ A431LP (1%) TC-92 (LP)
I808 (RB)	6640007706	IC VOLTAGE REGULATOR TL431ACL (1%) TO-92
I808 (RC)	6640007712	IC VOLTAGE REGULATOR TL431LN 1% TO-92
I871 (RA)	6640002705	IC VOLTAGE REGULATOR L7812CV 12V 1.5A
I871 (RB)	6640002000	IC VOLTAGE REGULATOR AN7812 12V 1.5A
I871 (RC)	6640002006	IC VOLTAGE REGULATOR H7812BE12V 1.5A
I871 (RD)	6640002003	IC VOLTAGE REGULATOR KIA7812API 12V 1.5A
IA01	6647008204	IC LSI MCU FLASH MTP NT68F62U SDIP-42 8BIT 32K
IA02 (RA)	6647051822	IC MEMORY EEPROM 8K 24LC08B/P DIP-8
IA02 (RB)	6647051823	IC MEMORY CMOS EEPROM AT24C08-10PC DIP-8
IA02 (RC)	6647051824	IC MEMORY CMOS EEPROM 24WC08P DIP-8
IA02 (RD)	6647051825	IC MEMORY CMOS EEPROM S524C80D81-DCB0 DIP-8

TRANSFORMER

CKT NO	Part no.	Description
T101 (RB)	5062628032	TRANSFORMER, FLYBACK COLOR TFB-280L-31
T401	5062420400	TRANSFORMER, HOR. DRIVE TLN-204, JSI
T801	5061369700	POWER TRANSFORMER, SWITCHING TPW-697

TRANSISTOR

CKT NO.	Part no.	Description
Q104	6621015332	TRANSISTOR NPN HF 2SC1815Y
Q104A	6621015332	TRANSISTOR NPN HF 2SC1815Y
Q104A	6621015335	TRANSISTOR NPN HF H945P
Q105	6621040730	TRANSISTOR NPN HF MPSA44 500V 0.6A TO-92
Q108	6624009232	TRANSISTOR PNP MPSA92
Q111	6621015332	TRANSISTOR NPN HF 2SC1815Y
Q114	6621015332	TRANSISTOR NPN 2SC1815Y
Q115	6623002050	TRANSISTOR PNP 2SA1015Y
Q116	6621015332	TRANSISTOR NPN 2SC1815Y
Q117	6623002050	TRANSISTOR PNP 2SA1015Y
Q118	6623002050	TRANSISTOR PNP 2SA1015Y
Q121	6626003203	TRANSISTOR FET MOS 2SK2843 600V 9A TO-220FI
Q123	6621006530	TRANSISTOR NPN BC548C
Q124	6626004000	TRANSISTOR FET MOS N-CH 2SK2161
Q125	6626006130	TRANSISTOR FET MOSFET BSN254A
Q126	6621006530	TRANSISTOR NPN BC548C
Q301	6621015332	TRANSISTOR NPN 2SC1815Y
Q302	6621015332	TRANSISTOR PNP 2SC1815Y
Q303	6621015332	TRANSISTOR NPN 2SC1815Y
Q306	6621018032	KTC3205Y
Q307	6623006332	KTA1273Y
Q400 (RA)	6621015332	TRANSISTOR NPN 2SC1815Y
Q400 (RB)	6621003230	TRANSISTOR NPN 2SC458C
Q401	6623002050	TRANSISTOR PNP 2SA1015Y
Q402	6626005702	TRANSISTOR FET MOSFET 2SJ512
Q404	6626005102	TRANSISTOR NPN LF 2SK2628
Q405	6622018000	TRANSISTOR NPN LF 2SD882Q
Q410	6626003903	TRANSISTOR FET MOS RDN15ON20
Q411 (RA)	6621026430	TRANSISTOR NPN BF422
Q411 (RB)	6621026401	TRANSISTOR NPN BF422
Q412	6626003903	TRANSISTOR FET MOS RDN15ON20
Q413 (RA)	6621026430	TRANSISTOR NPN BF422
Q413 (RB)	6621026401	TRANSISTOR NPN BF422
Q414 (RA)	6626000605	TRANSISTOR FET MOS IRFS630A
Q414 (RB)	6626000604	TRANSISTOR FET MOS IRFS630MFP
Q414 (RC)	6626004000	TRANSISTOR FET MOSFET N-CH 2SK2161

CKT NO.	Part no.	Description
Q415 (RA)	6621026430	TRANSISTOR NPN BF422
Q415 (RB)	6621026401	TRANSISTOR NPN BF422
Q416 (RA)	6626000605	TRANSISTOR FET MOS IRFS630A
Q416 (RB)	6626000604	TRANSISTOR FET MOS IRFS630MFP
Q416 (RC)	6626004000	TRANSISTOR FET MOSFET N-CH 2SK2161
Q417 (RA)	6621026430	TRANSISTOR NPN BF422
Q417 (RB)	6621026401	TRANSISTOR NPN BF422
Q423	6622018000	TRANSISTOR NPN LF 2SD882Q
Q424	6624001300	TRANSISTOR NPN LF 2SB772
Q426	6621015332	TRANSISTOR NPN 2SC1815Y
Q427	6621018032	KTC3205Y
Q428	6623006332	KTA1273Y
Q429	6623002050	TRANSISTOR PNP 2SA1015Y
Q430	6621015332	TRANSISTOR NPN 2SC1815Y
Q433	6621040405	TRANSISTOR NPN HF 2SC5587AS
Q471	6623006332	TRANSISTOR PNP HF KTA1273
Q472	6621018032	TRANSISTOR NPN HF KTC3205Y
Q473 (RA)	6621015335	TRANSISTOR NPN HF H945P
Q473 (RB)	6621015332	TRANSISTOR NPN HF 2SC1815Y
Q475	6624001300	TRANSISTOR PNP HF 2SB772
Q476	6621015332	TRANSISTOR NPN HF 2SC1815Y
Q801	6626003208	TRANSISTOR FET MOSFET N-CH FJUI 2SK2648-01
Q804	6621015332	TRANSISTOR NPN 2SC1815Y
Q805	6621015332	TRANSISTOR NPN 2SC1815Y
Q806	6624001300	TRANSISOR PNP LF 2SB772
Q807	6623002050	TRANSISTOR PNP 2SA1015Y
Q808	6621015332	TRANSISTOR NPN 2SC1815Y
Q810	6621040730	TRANSISTOR NPN MPSA44
Q811	6621015332	TRANSISTOR NPN 2SC1815Y
Q814	6621015332	TRANSISTOR NPN 2SC1815Y
Q815	6621040730	TRANSISTOR NPN MPSA44
Q816	6621015332	TRANSISTOR NPN 2SC1815Y
Q866	6624001300	TRANSISTOR PNP 2SB722
Q867	6621015332	TRANSISTOR NPN 2SC1815Y
Q872	6621015332	TRANSISTOR NPN 2SC1815Y
QA01	6621015332	TRANSISTOR NPN 2SC1815Y
QA02	6621015332	TRANSISTOR NPN 2SC1815Y
QA03	6621015332	TRANSISTOR NPN 2SC1815Y

COIL

CKT NO.	Part no.	Description
B801	5062122949	CORE, BEAD RH03506ST-B
L101	5064433025	COIL, PEAKING TRF-8330J 33UH J
L102	5064433025	COIL, PEAKING TRF-8330J 33UH J
L103	5062122949	CORE, BEAD RH03506ST-B
L105	5062124403	COIL, CHOKE B-6-22A (0), BC0610R6HB-B3
L106	5062122946	CORE, BEAD RH03506AT-B
L300	5062118309	CORE, BEAD RH035047ST-Y7
L301	5064433025	CORE, BEAD TRF-8330J
L401	5062419900	TRANS, HOR. DRIVG TLN-199
L402	5062230400	COIL, HOR.LINEARITY TLH-304
L403	5062422500	TRANS, DYAMIC FOCUS TDF-225
L404	5062117701	COIL, CHOKE CHK-177A
L405	5062229000	COIL, HOR.CHOKE TCH-290
L406	5062128707	CHK-287G
L407	5062127418	3.5Ø X 0.6Ø X 3mm
L801	5061111000	FILTER, EMI TRANSFORMER TYPE TLF-110
L802	5061111000	FILTER, EMI TRANSFORMER TYPE TLF-110
L805	5061101000	COIL, BEAD HC5-035, BF45HZ-3.5X11X0.8
L870	5062202300	COIL, HOR.CHOKE TLN-2026
L871	5062123001	COIL, HOR. CHOKE CHK-230A
L872	5062202300	COIL, HOR.CHOKE TLN-2026
L873	5062117701	COIL, HOR. CHOKE CHK-177A
L874	5062123001	COIL, HOR.CHOKE CHK-230A
L875	5062202300	COIL, HOR. CHOKE TLN-2026
L876	5062122971	CORE, BEAD RH035078ST-B
L877	5062123001	CORE, CHOKE CHK-230A

CRYSTAL

CKT NO	Part no.	Description
XA01 (RA)	6699003504	CST8.00MTW(TCR-1056)

RELAY

CKT NO	Part no.	Description
SR401	5054633000	RUDH-SS-11201
SR801	5054613402	RELAY OSA-SS-212DM5

RESISTOR

CKT NO	Part no.	Description	CKT NO	Part no.	Description
R100	5130420206	R. CF 2W 2K J	R159	5142110095	R. CF 1/6W 10 J
R100A	5130420206	R. CF 2W 2K J	R160	5142147195	R. CF 1/6W 470 J
R101	5142433490	R. CF 1/2W 330K J	R161	5142110195	R. CF 1/6W 100 J
R102	5142433490	R. CF 1/2W 330K J	R162	5142822995	R. CF 1/4W 2.2 J
R103	5142162195	R. CF 1/6W 620 J	R163	5130322203	R. MOF 1W 2.2K J
R104	5142818395	R. CF 1/4W 18K J	R164	5130310403	R. MOF 1W 100K J
R105	5142110295	R. CF 1/6W 1K J	R165	5142110495	R. CF 1/6W 100K J
R106	5142891395	R. CF 1/4W 91K J	R166	5142156295	R. CF 1/6W 5.6K J
R107	5142836395	R. CF 1/4W 36K J	R167	5162162220	R. VR B 22K M
R108	5142151295	R. CF 1/6W 5.1K J	R168	5142147395	R. CF 1/6W 47K J
R111	5142833195	R. CF 1/4W 330 J	R171	5142856295	R. CF 1/4W 5.6K J
R112	5142112295	R. CF 1/6W 1.2K J	R172	5142127295	R. CF 1/6W 2.7K J
R118	5142815295	R. CF 1/4W 1.5K J	R173	5142802095	R. CF 1/4W 2 J
R119	5142810195	R. CF 1/4W 100 J	R175	5142162395	R. CF 1/6W 62K J
R120	5130451303	R. MOF 2W 51K J	R176	5162162820	R. VR B 100K M
R121	5142415590	R. CF 1/2W 1.5M J	R177	5142862395	R. CF 1/4W 62K J
R121A	5142415590	R CF 1/2W 1.5M	R179	5130415803	R MOF 2W 0.15 J
R124	5142182195	R. CF 1/6W 820 J	R180	5142430490	R. CF 1/2W 300K J
R126	5142110295	R. CF 1/6W 1K J	R301	5134756018	R. MF 1/6W 5.6K F
R127	5142112195	R. CF 1/6W 120 J	R302	5142133295	R. CF 1/6W 3.3K J
R128	5142133395	R. CF 1/6W 33K J	R303	5142110395	R. CF 1/6W 10K J
R129	5142115495	R. CF 1/6W 150K J	R304	5142110495	R. CF 1/6W 100K J
R130	5142127295	R. CF 1/6W 2.7K J	R306	5142112395	R. CF 1/6W 11K J
R131	5142847095	R. CF 1/4W 47 J	R307	5142133295	R. CF 1/6W 3.3K J
R132	5142422390	R. CF 1/2W 22K J	R308	5142116295	R. CF 1/6W 1.6K J
R135	5142833395	R. CF 1/4W 33K J	R309	5142110295	R. CF 1/6W 1K J
R136	5134718018	R. MF 1/6W 1.8K J	R310	5142122495	R. CF 1/6W 220K J
R137	5134715018	R. MF 1/6W 1.5K J	R311	5142122195	R. CF 1/6W 220 J
R138	5142147295	R. CF 1/6W 4.7K J	R312	5142147395	R. CF 1/6W 47K J
R139	5142110295	R. CF 1/6W 1K J	R313	5142110395	R CF 1/6W 10K J
R140	5142182195	R. CF 1/6W 820 J	R314	5142120295	R. CF 1/6W 2K J
R141	5142110295	R. CF 1/6W 1K J	R315	5142110195	R. CF 1/6W 100 J
R142	5142810495	R. CF 1/4W 100K J	R316	5142110195	R. CF 1/6W 100 J
R154	5142110095	R. CF 1/6W 10 J	R317	5142110295	R. CF 1/6W 1K J
R155	5142110395	R. CF 1/6W 10K J	R318	5142143295	R. CF 1/6W 4.3K J
R156	5142147195	R. CF 1/6W 470 J	R319	5142120495	R. CF 1/6W 200K J
R157	5130439003	R. MOF 2W 39 J	R320	5142115395	R. CF 1/6W 15K J
R158	5142810095	R. CF 1/4W 10 J	R321	5142122095	R. CF 1/6W 22 J

CKT NO	Part no.	Description	CKT NO	Part no.	Description
R322	5142110195	R. CF 1/6W 100 J	R432	5142815495	R. CF 1/4W 150K J
R323	5142110195	R. CF 1/6W 100 J	R437	5142847395	R. CF 1/4W 47K J
R324	5142815395	R. CF 1/4W 15K J	R438	5142815495	R. CF 1/4W 150K J
R325	5142815395	R. CF 1/4W 15K J	R439	5142110395	R. CF 1/6W 10K J
R326	5142127395	R. CF 1/6W 27K J	R440	5142110395	R. CF 1/6W 10K J
R327	5142139295	R. CF 1/6W 3.9K J	R441	5142110395	R. CF 1/6W 10K J
R329	5142110395	R. CF 1/6W 10K J	R442	5142168395	R. CF 1/6W 68K J
R330	5142110395	R. CF 1/6W 10K J	R443	5142110395	R. CF 1/6W 10K J
R331	5142168395	R. CF 1/6W 68K J	R444	5142124195	R. CF 1/6W 240 J
R332	5142110395	R. CF 1/6W 10K J	R445	5142810095	R. CF 1/4W 10 J
R333	5142124195	R. CF 1/6W 240 J	R446	5142843295	R. CF 1/4W 4.3K J
R334	5142810095	R. CF 1/4W 10 J	R447	5142810095	R. CF 1/4W 10 J
R335	5142143295	R. CF 1/6W 4.3K J	R448	5142115295	R. CF 1/6W 1.5K J
R336	5142810095	R. CF 1/4W 10 J	R449	5142810095	R. CF 1/4W 10 J
R384	5130468903	R. MOF 2W 6.8 J	R450	5142127295	R. CF 1/6W 2.7K J
R385	5142110395	R. CF 1/6W 10K J	R451	5142827195	R. CF 1/4W 270 J
R386	5130456903	R. MOF 2W 5.6 J	R452	5130468906	R. MOF 2W 6.8 J 2U
R388	5142415990	R. CF 1/2W 1.5 J	R453	5130410006	R. MOF 2W 10 J UB
R389	5130415903	R. MOF 2W 1.5 J	R454	5162561980	R. VR B 10K M
R390	5142433190	R. CF 1/2W 330 J	R455	5142868195	R. CF 1/4W 680 J
R400	5142810195	R. CF 1/4W 100 J	R456	5142868195	R. CF 1/4W 680 J
R401	5130222007	R. MOF 1/2W 22 J	R472	5142143295	R. CF 1/6W 4.3K J
R402	5130468003	R. MOF 2W 68 J	R473	5142810095	R. CF 1/4W 10 J
R403	5142812195	R. CF 1/4W 120 J	R474	5142810095	R. CF 1/4W 10 J
R404	5142810395	R. CF 1/4W 10K J	R475	5142110395	R. CF 1/6W 10K J
R406A	5130456106	2W 560J UB	R476	5142824195	R. CF 1/4W 240 J
R407	5130556103	R. MOF 3W 560 J	R477	5142868395	R. CF 1/4W 68K J
R409	5142822295	R. CF 1/4W 2.2K J	R478	5142810395	R. CF 1/4W 10K J
R410	5142810195	R. CF 1/4W 100 J	R479	5142130395	R. CF 1/6W 30K J
R412	5142810395	R. CF 1/4W 10K J	R480	5142810295	R. CF 1/4W 1K J
R414	5130510103	R. MOF 3W 100 J	R481	5142110395	R. CF 1/6W 10K J
R415	5130520003	R. MOF 3W 20 J	R801	5142482490	R. CF 1/2W 820K J
R417	5136000100	R. MOF 5W 1.0 K	R802	5142833195	R. CF 1/4W 330 J
R419	5142110195	R. CF 1/6W 100 J	R803	5101115300	R.THERMISTOR, POSITIVE DGC2R07N
R420	5142810295	R. CF 1/4W 1K J	R804 (RA)	5101114200	R.THERMISTOR GC-P 10D 100
R426	5142815495	R. CF 1/4W 150K J	R804 (RB)	5101118400	R. THERMISTOR PROTECTORS 10 L 3A
R427	5142847395	R. CF 1/4W 47K J			
R429	5142815495	R. CF 1/4W 150K J			
R430	5142847395	R. CF 1/4W 47K J			

CKT NO	Part no.	Description	CKT NO	Part no.	Description
R806	5142882495	R. CF 1/4W 820K J	R850	5142110295	R. CF 1/6W 1K J
R807	5130324803	R. FU MOF 1W 0.24 J	R852	5142110395	R. CF 1/6W 10K J
R808	5142815395	R. CF 1/4W 15 K J	R856	5142810395	R. CF 1/4W 10K J
R809	5142851495	R. CF 1/4W 510K J	R857	5142812295	R. CF 1/4W 1.2K J
R810	5142851495	R. CF 1/4W 510K J	R862	5142151295	R. CF 1/6W 5.1K J
R811	5130410303	R. MOF 2W 10K J	R866	5130539903	R. MOF 3W 3.9 J
R812	5130410303	R. MOF 2W 10K J	R867	5142812295	R. CF 1/4W 1.2K J
R813	5130510403	R. MOF3W 100K J	R868	5142810295	R. CF 1/4W 1K J
R814	5142851995	R. CF 1/4W 5.1 J	R869	5142147395	R. CF 1/6W 47K J
R815	5142810195	R. CF 1/4W 100 J	R871	5142127295	R. CF 1/6W 2.7K J
R816	5142810395	R. CF 1/4W 10K J	R872	5142843295	R. CF 1/4W 4.3 K J
R817	5142143295	R. CF 1/6W 4.3K J	R873	5142151295	R. CF 1/6W 5.1K J
R817A	5162161720	R. VR 5K M	R874	5142120295	R. CF 1/6W 2K J
R818	5142810495	R. CF 1/4W 100K J	R875	5142810395	R. CF 1/4W 10K J
R819	5142847295	R. CF 1/4W 4.7K J	R876	5142182195	R. CF 1/6W 820 J
R821	5142115395	R. CF 1/6W 15K J	R877	5142856295	R. CF 1/4W 5.6K J
R823	5142147395	R. CF 1/6W 47K J	R880	5130410003	R. MOF 2W 10 J
R824	5142120295	R. CF 1/6W 2.0K J	R882	5130315003	R. MOF 1W 15 J
R825	5142827395	R. CF 1/4W 27K J	RA01	5142112395	R. CF 1/6W 12KJ
R826	5142810295	R. CF 1/4W 1K J	RA01A	5142156295	R. CF 1/6W 5.6KJ
R827	5162161220	R. VR 2K M	RA02	5142110495	R. CF 1/6W 100k J
R828	5142810195	R. CF 1/4W 100 J	RA03	5142110495	R. CF 1/6W 100k J
R829	5142851295	R. CF 1/4W 5.1K J	RA05	5142110395	R. CF 1/6W 10K J
R831	5130420803	R. MOF 2W 0.2 J	RA06	5142810395	R. CF 1/4W 10K J
R832	5142810295	R. CF 1/4W 1K J	RA07	5142810395	R. CF 1/4W 10K J
R833	5142110295	R. CF 1/6W 1K J	RA08	5142810395	R. CF 1/4W 10K J
R834	5142816395	R. CF 1/4W 16K J	RA09	5142110195	R. CF 1/6W 100 J
R835	5142810395	R. CF 1/4W 10K J	RA10	5142110195	R. CF 1/6W 100 J
R836	5130582003	R. MOF 3W 82 J	RA11	5142110195	R. CF 1/6W 100 J
R837	5142818495	R. CF 1/4W 180K J	RA12	5142110195	R. CF 1/6W 100 J
R838	5142818495	R. CF 1/4W 180K J	RA13	5142110195	R. CF 1/6W 100 J
R839	5142818495	R. CF 1/4W 180K J	RA14	5142133195	R. CF 1/6W 330 J
R840	5142818495	R. CF 1/4W 180K J	RA15	5142110295	R. CF 1/6W 1K J
R841	5142110395	R. CF 1/6W 10K J	RA16	5142127095	R. CF 1/6W 27 J
R842	5142813195	R. CF 1/4W 130 J	RA18	5142110295	R. CF 1/6W 1K J
R844	5142812095	R. CF 1/4W 12 J	RA19	5142110395	R. CF 1/6W 10K J
R845	5142110295	R. CF 1/6W 1K J	RA20	5142110395	R. CF 1/6W 10K J
R847	5142851295	R. CF 1/4W 5.1K J	RA21	5142110395	R. CF 1/6W 10K J
R848	5142843395	R. CF 1/4W 43K J	RA22	5142110395	R. CF 1/6W 10K J

CKT NO	Part no.	Description
RA23	5142110395	R. CF 1/6W 10K J
RA24	5142151195	R. CF 1/6W 510 J
RA24A	5142156295	R. CF 1/6W 5.6K J
RA25	5142147295	R. CF 1/6W 4.7K J
RA26	5142151295	R. CF 1/6W 5.1K J
RA27	5142110295	R. CF 1/6W 1K J
RA28	5142110295	R. CF 1/6W 1K J
RA29	5142110295	R. CF 1/6W 1K J
RA30	5142147295	R. CF 1/6W 4.7K J
RA31	5142147295	R. CF 1/6W 4.7K J
RA32	5142110195	R. CF 1/6W 100 J
RA33	5142110195	R. CF 1/6W 100 J
RA34	5142168195	R. CF 1/6W 680 J
RA35	5142115295	R. CF 1/6W 1.5K J
RA36	5142115295	R. CF 1/6W 1.5K J
RA37	5142110295	R. CF 1/6W 1K J
RA38	5142810395	R. CF 1/4W 10K J
RA38A	5142810395	R. CF 1/4W 10K J

CKT NO	Part no.	Description
RA39	5142110295	R. CF 1/6W 1K J
RA40	5142810195	R. CF 1/4W 100 J
RA41	5142110395	R. CF 1/6W 10K J
RA42	5142168395	R. CF 1/6W 68K J
RA42A	5142822295	R. CF 1/4W 2.2K J
RA43	5142139295	R. CF 1/6W 3.9K J
RA44	5142110395	R. CF 1/6W 10K J
RA45	5142110395	R. CF 1/6W 10K J
RA46	5142110395	R. CF 1/6W 10K J
RA47	5142110395	R. CF 1/6W 10K J
RA48	5142133195	R. CF 1/6W 330 J
RA49	5142122295	R. CF 1/6W 2.2K J
RA50	5142110295	R. CF 1/6W 1K J
RA51	5142110195	R. CF 1/6W 100 J
RA52	5142110195	R. CF 1/6W 100 J
RA53	5142147295	R. CF 1/6W 4.7K J
RA54	5142147295	R. CF 1/6W 4.7K J
RA55	5142812295	R. CF 1/4W 1.2K J

P.C.B BOARD

CKT NO	Part no.	Description
U0404	5053104040	PCB, MAIN BOARD PWB-0404

FUSE

F801	5054431539	FUSE 250V/3.15A
F801A	5056506400	FUSE HOLDER

SPARK GAP

Z101 (RA)	5202200591	SPARK GAP 1-2KV 1PF(MAX)
Z101 (RB)	5202200502	SPARK GAP 1-2KV 1PF(MAX)
Z101 (RC)	5202200501	SPARK GAP 1KV 1PF(MAX)
Z801 (RA)	5202200591	SPARK GAP 1-2KV 1PF(MAX)
Z801 (RB)	5202200502	SPARK GAP 1-2KV 1PF(MAX)
Z803 (RA)	5202201991	SPARK GAP 200V 1PF (MAX)
Z803 (RB)	5202201301	SPARK GAP 200V 1PF (MAX)
Z805 (RA)	5202201991	SPARK GAP 200V 1PF (MAX)
Z805 (RB)	5202201301	SPARK GAP 200V 1PF (MAX)
Z809 (RA)	5202200591	SPARK GAP 1-2KV 1PF(MAX)
Z809 (RB)	5202200502	SPARK GAP 1-2KV 1PF(MAX)

BASE & PIN

CKT NO	Part no.	Description
P02A		
P301	5057415224	WIRE ASS'Y W/15P CONNUL/CSA1007#24 L=330MM
P302	5057404300	WIRE ASS'Y W/15P CONN UL/CSA1007#24 JST/JAE 400mm
P400	5056203901	PIN RT-01N-2.3A
P401	5056407801	BASE & PIN 2.36mm 4P(UL/CSA/TUV)
P409	5056203901	PIN RT-01N-2.3A
P410	5056203901	PIN RT-01N-2.3A
P420	5056415617	BASE & PIN
P421	5057405136	WIRE ASS'Y L=320MM
P422	5056415326	BASE & PIN 3P
P800	5057402199	WIRE ASS'Y W/2P CONN UL/CSA 1617 #22 LSINX2/SINX2350
P801	5056513117	AC SOCKEY 7014(A)
P803	5056415207	BASE & PIN 2.36mm 2P(UL/CSA/TUV)
PA03	5057402320	WIRE ASS'Y W/15P CONN

OTHERS

CKT NO	Part no.	Description
SA01	5054513025	TACT SWITCH SKHHLV1720-TT DC12V 50MA GRAY
SA02	5054513025	TACT SWITCH SKHHLV1720-TT DC12V 50MA GRAY
SA03	5054513025	TACT SWITCH SKHHLV1720-TT DC12V 50MA GRAY
SA04	5054513025	TACT SWITCH SKHHLV1720-TT DC12V 50MA GRAY
SA05	5054513025	TACT SWITCH SKHHLV1720-TT DC12V 50MA GRAY
SA06	5054513025	TACT SWITCH SKHHLV1720-TT DC12V 50MA GRAY

ASSEMBLY PCB-PFC

CKT NO	Part no.	Description
C1	5214147012	C. EL 100V 47UF
C2	5213422191	C. EL 25V 220UF
D1	6611035644	RGP10D
D2	6613003032	1N4148
D3	6613003032	1N4148
D4	6615007834	HZ5C1
D5	6615007834	HZ5C1
I2	6644007300	LM358P
P01	5056415567	BASE & PIN
P02	5056405309	BASE & PIN
Q1	6621015332	TRANSISTOR NPN 2SC1815Y
Q2	6621015332	TRANSISTOR NPN 2SC1815Y
R1	5142111495	R. CF 1/6W 110K J
R10	5142113395	R. CF 1/6W 13K J
R11	5142110295	R. CF 1/6W 1.0K J
R12	5142127295	R. CF 1/6W 2.7K J
R2	5142110395	R. CF 1/6W 10K J
R3	5142110395	R. CF 1/6W 10K J
R4	5142130495	R. CF 1/6W 300K J
R5	5142130395	R. CF 1/6W 30K J
R6	5142120395	R. CF 1/6W 20K J
R7	5142456090	R. CF 1/2W 56 J
R8	5142110295	R. CF 1/6W 1.0K J
R9	5142110295	R. CF 1/6W 1.0K J
SR1	5054633004	RELAY OMI-SS-212L
U0344	5053103440	PWB-0344-00

ASSEMBLY PCB PURITY

ASSEMBLY, PCB-PURITY 5097609000

CKT NO.	Part no.	Description
---------	----------	-------------

CAPACITOR

C501	5236310491	C. BL 50V 0.1UF Z
C502	5236310491	C. BL 50V 0.1UF Z
C503	5236310491	C. BL 50V 0.1UF Z
C504	5236310491	C. BL 50V 0.1UF Z
C505	5236310491	C. BL 50V 0.1UF Z
C506	5236310491	C. BL 50V 0.1UF Z
C507	5236310491	C. BL 50V 0.1UF Z
C508	5236310491	C. BL 50V 0.1UF Z
C509	5236310491	C. BL 50V 0.1UF Z
C510	5236310491	C. BL 50V 0.1UF Z
C511	5236310491	C. BL 50V 0.1UF Z
C512	5236310491	C. BL 50V 0.1UF Z
C513	5213310191	C. EL 50V 100UF M

IC

I501	6649000600	TDA8444
------	------------	---------

TRANSISTOR

Q501	6621015332	TRANSISTOR NPN 2SC1815Y
Q502	6621015332	TRANSISTOR NPN 2SC1815Y
Q503	6621015332	TRANSISTOR NPN 2SC1815Y
Q504	6621015332	TRANSISTOR NPN 2SC1815Y
Q505	6621015332	TRANSISTOR NPN 2SC1815Y
Q506	6621015332	TRANSISTOR NPN 2SC1815Y
Q507	6621015332	TRANSISTOR NPN 2SC1815Y
Q508	6621015332	TRANSISTOR NPN 2SC1815Y
Q509	6621015332	TRANSISTOR NPN 2SC1815Y
Q510	6621015332	TRANSISTOR NPN 2SC1815Y
Q511	6621015332	TRANSISTOR NPN 2SC1815Y
Q512	6621015332	TRANSISTOR NPN 2SC1815Y
Q513	6621015332	TRANSISTOR NPN 2SC1815Y
Q514	6621015332	TRANSISTOR NPN 2SC1815Y
Q515	6621015332	TRANSISTOR NPN 2SC1815Y
Q516	6621015332	TRANSISTOR NPN 2SC1815Y

RESISTOR

R501	5142127095	R. CF 1/6W 27 J
R502	5142127095	R. CF 1/6W 27 J

CKT NO.	Part no.	Description
R503	5142127095	R. CF 1/6W 27 J
R504	5142127095	R. CF 1/6W 27 J
R505	5142827095	R. CF 1/4W 27 J
R506	5142827095	R. CF 1/4W 27 J
R507	5142827095	R. CF 1/4W 27 J
R508	5142827095	R. CF 1/4W 27 J
R509	5142827095	R. CF 1/4W 27 J
R510	5142827095	R. CF 1/4W 27 J
R511	5142827095	R. CF 1/4W 27 J
R512	5142827095	R. CF 1/4W 27 J
R513	5142127095	R. CF 1/6W 27 J
R514	5142127095	R. CF 1/6W 27 J
R515	5142127095	R. CF 1/6W 27 J
R516	5142127095	R. CF 1/6W 27 J
R517	5142127095	R. CF 1/6W 27 J
R518	5142127095	R. CF 1/6W 27 J

BASE & PIN

P501	5056403404	BASE & PIN 4P
P502	5056403404	BASE & PIN 4P
P503	5056403504	BASE & PIN 5P

PCB

U0417	5053104170	PWB-0417-01
-------	------------	-------------

**ASSEMBLY PCB-CRT DRIVE (PWB-0414)
CAPACITOR**

CKT NO	Part no.	Description	CKT NO	Part no.	Description
C900	5242210191	C. CE 50V 100PF J	C932	5236310491	C. BL 50V 0.1UF Z
C900A	5242210191	C. CE 50V 100PF J	C933	5216301091	C. EL 200V 1UF M
C901	5213601091	C. EL 50V 1UF M	C933A	5232356191	C. CE 500V 560PF K
C902	5236310491	C. BL 50V 0.1UF Z	C934	5213333191	C. EL 16V 330UF M
C903	5216301091	C. EL 200V 1UF M	C934B	5233310291	C. CE 1KV 1000PF K
C904	5231347191	C. CE 50V 470PF K	C935	5214110091	C. EL 100V 10UF M
C905	5214110091	C. EL 100V 10UF M	C936	5236310491	C. BL 50V 0.1UF Z
C906	5276110491	C. ME 100V 0.1UF J	C937	5233310291	C. CE 1KV 1000PF K
C907	5214147012	C. EL 100V 47UF M	C947	5214147012	C. EL 100V 47UF M
C907B	5276110491	C. ME 100V 0.1UF M	C950	5247318091	C. CE 500V 18PF J
C908	5231310391	C. CE 50V 10000PF K	C953	5236310491	C. BL 50V 0.1UF Z
C908A	5231310391	C. CE 50V 10000PF K	C953A	5213310191	C. EL 16V 100UF M
C910	5242210191	C. CE 50V 100PF J	C954	5236310491	C. BL 50V 0.1UF Z
C911	5213410191	C. EL 25V 100UF M	C958	5213410191	C. EL 25V 100UF M
C911A	5233310291	C. CE 1KV 1000PF K	C958A	5236310491	C. BL 50V 0.1UF Z
C912	5242210191	C. CE 50V 100PF J	C960	5213222191	C. EL 10V 220UFM
C913	5213647891	C. EL 50V 0.47UF M	C961	5213601091	C. EL 50V 1UF M
C914	5233310291	C. CE 1KV 1000PF K	C963	5216301091	C. EL 200V 1U F M
C915	5242210191	C. CE 50V 100PF J	C965	5214110091	C. EL 100V 10UF M
C916	5232315291	C. CE 500V 1500PF K	C970	5231310391	C. CE 50V 10000PF K
C917	5210502191	C. EL 50V 2.2UF M	C971	5247082191	SL DC 50V 820PFJ
C918	5232310301	C. CE 500V 10000PF K	C972	5231310391	C. CE 50V 10000PF K
C920	5214410012	C. EL 250V 10UF M	C973	5213410191	C. EL 25V 100UF M
C920A	5232310301	C. CE 500V 10000PF K	C978	5213210191	C. EL 10V 100UF M
C922	5232310291	C. CE 500V 1000PF K	C979	5236310491	C. BL 50V 0.1UF Z
C923	5236310491	C. BL 50V 0.1UF Z	C983	5213322191	C. EL 16V 220UF M
C925	5213410191	C. EL 25V 100UF M	C983A	5236310491	C. BL 50V 0.1UF Z
C925A	5236310491	C. BL 50V 0.1UF Z	C984	5213610091	C. EL 50V 10UF M
C926	5233547201	C. CE 1KV 4700PF M			
C926A	5233310191	C. CE 1KV 100PF K			
C926B	5233318191	C. CE 1KV 180PF K			
C927	5231310391	C. CE 50V 10000PF K			
C930B	5242210191	C. CE 50V 100PF J			
C931	5213601091	C. EL 50V 1UF M			

SEMICONDUCTOR.

DIODE

CKT NO	Part no.	Description
D901*	6613003032	DIODE SWITCHING 1N4148-TD 75V 150mA (RA.RB.RC.RD)
D902*	6613003032	DIODE SWITCHING 1N4148-TD 75V 150mA (RA.RB.RC.RD)
D903#	6611036040	DIODE RECTIFIER BAV21
D904	6613004934	DIODE SWITCHING 1SS133
D913*	6613003032	DIODE SWITCHING 1N4148-TD 75V 150mA (RA.RB.RC.RD)
D931*	6613003032	DIODE SWITCHING 1N4148-TD 75V 150mA (RA.RB.RC.RD)
D932*	6613003032	DIODE SWITCHING 1N4148-TD 75V 150mA (RA.RB.RC.RD)
D933#	6611036040	DIODE RECTIFIER BAV21
D934	6613004934	DIODE SWITCHING 1SS133
D941*	6613003032	DIODE SWITCHING 1N4148-TD 75V 150mA (RA.RB.RC.RD)
D943*	6613003032	DIODE SWITCHING 1N4148-TD 75V 150mA ((RA.RB.RC.RD)
D961*	6613003032	DIODE SWITCHING 1N4148-TD 75V 150mA (RA.RB.RC.RD)
D962*	6613003032	DIODE SWITCHING 1N4148-TD 75V 150mA (RA.RB.RC.RD)
D963	6611036040	DIODE RECTIFIER BAV21
D964	6613004934	DIODE SWITCHING 1SS133
D966 (RA)	6615009752	DIODE ZENER RD6.8EB2-T7
D966 (RB)	6615007234	DIODE ZENER HZ7B1-TD 6.7-7V
D973*	6613003032	DIODE SWITCHING 1N4148-TD 75V 150mA (RA.RB.RC.RD)
D974	6615007834	DIODE ZENER HZ5C1 4.9-5.1V
D990	6611070541	DIODE RECTIFIER SBD 1N5817

PS: * 1N4148 RA 6613003032 RB 6613003037 RC 6613003048
BAV21 RA6611036040 RB 6611032741

IC

I901	6644076905	IC, LINEAR VIDEO PER.AMP.M52743BSP SDIP-36
I903	6645008907	IC, DIGITAL OSD MTV038N20 DIP-20
I904	6644009606	IC, LINEAR VIDEO AMP. LM2435 T 9PIN

COIL

L905	5062122946	CORE, BEAD RH03506AT-B
L906	5062133201	BEAD CORE
L907	6119210605	JUMP WIRE
L911	5062133201	BF30TA-2.5 X 3 X 1B
L912	5064456845	COIL, PEAKING TRF-8568M 0.56UH K
L921	5062122902	CORE, BEAD BL03RN2-R62T4
L935	5062122946	CORE, BEAD RH03506AT-B

CKT NO	Part no.	Description
L941	5062133201	BF30TA-2.5 X 3 X 1B
L942	5064456845	COIL, PEAKING TRF-8568M 0.56UH K
L951	5062122902	CORE,BEAD BL03RN2-R62T4
L953	5064010029	COIL, PEAKING TRF-3100J 10UH J
L965	5062122946	CORE, BEAD RH03506AT-B
L971	5062133201	BF30TA-2.5 X 3 X 1B
L972	5064456845	COIL, PEAKING TRF-8568M 0.56UH K
L979	5062119801	COIL, CHOKE EMI CHK-198
L980	5062202300	COIL, HOR CHOKE TLN-2026
L981	5062202300	COIL, HOR CHOKE TLN-2026
L982	5062202300	COIL, HOR CHOKE TLN-2026
L983	5062122902	CORE, BEAD BL03RN2-R62T4

BASE & PIN

CKT NO	Part no.	Description
P901	5056404404	BASE & PIN 14P(2.5mm) IL-G-14P-S3T2-E
P902	5056406500	BASE & PIN IL-G-15P-S3T2-E
P903	5056403404	BASE & PIN 4P(2.5mm-I) IL-G-4P-S3T2-E
P904	5056403204	BASE & PIN 2P(2.5mm-I) IL-G-2P-S3T2-E
P906	5056203901	PIN RT-01N-2.3A
P910A	5057401407	WIRE ASS'Y W/01P CONN 6X24/0.12 P11351 L=360mm
P911A	5057401311	WIRE ASS'Y W/01P CONN 144C P11531 L=190mm
P912A	5057401408	WIRE ASS'Y W/01P CONN 6X24/0.12 SMT1741BS-2 L=95mm
P913A	5057401403	WIRE ASS'Y W/01P CONN 96C/0.12mm 1741BS-2/UL/CSAL190
P922	5056404522	BASE & PIN 1.56mm 2P(UL/CSA/TUV)

TRANSISTOR

CKT NO	Part no.	Description
Q903 (RA)	6621026430	TR NPN HF BF422
Q903 (RB)	6621026401	TR NPN HF BF422
Q910 (RA)	6621015332	TR NPN HF 2SC1815Y
Q933 (RA)	6621026430	TR NPN HF BF422
Q933 (RB)	6621026401	TR NPN HF BF422
Q963 (RA)	6621026430	TR NPN HF BF422
Q963 (RB)	6621026401	TR NPN HF BF422
Q964 (RA)	6621026430	TR NPN HF BF422
Q964 (RB)	6621026401	TR NPN HF BF422
Q987 (RA)	6621015332	TR NPN HF 2SC1815Y
Q988 (RA)	6621015332	TR NPN HF 2SC1815Y

RESISTOR

CKT NO	Part no.	Description	CKT NO	Part no.	Description
R900	5142110295	R. CF 1/6W 1K J	R939	5142868195	R.CF 1/4W 680 J
R901	5142175095	R. CF 1/6W 75 J	R939A	5142113295	R. CF 1/6W 1.3K J
R902	5142113395	R. CF 1/6W 13K J	R940	5062122949	BEAD CORE
R903	5142118295	R. CF 1/6W 1.8K J	R940A	5142191095	R. CF 1/6W 91 J
R904	5142822095	R. CF 1/4W 22 J	R942	5142113395	R. CF 1/6W 13K J
R905	5142182295	R. CF 1/6W 8.2K J	R943	5142824095	R. CF 1/4W 24 J
R905A	5142113495	R. CF 1/6W 130K J	R946	5142810595	R. CF 1/4W 1M J
R906	5142810295	R. CF 1/4W 1K J	R947	5130362303	R. MOF 1W 62K J
R907	5142815195	R. CF 1/4W 150 J	R948	5142110195	R. CF 1/6W 100 J
R908	5142843095	R. CF 1/4W 43 J	R949	5142110195	R. CF 1/6W 100 J
R909	5142168195	R. CF 1/6W 680 J	R950	5142168495	R. CF 1/6W 680K J
R909A	5142113295	R. CF 1/6W 1.3K J	R952	5142410590	R. CF 1/2W 1M J
R910	5142139195	R. CF 1/6W 390 J	R952A	5130310003	R. MOF 1W 10 J
R912	5142813395	R. CF 1/4W 13K J	R954	5142810295	R. CF 1/4W 1K J
R913	5142862095	R. CF 1/4W 62 J	R955	5142110295	R. CF 1/6W 1K J
R914	5142847090	R. CF 1/4W 47 J	R961	5142175095	R. CF 1/6W 75 J
R915	5142110395	R. CF 1/6W 10K J	R964	5142822095	R. CF 1/4W 22 J
R916	5142810595	R. CF 1/4W 1M J	R965	5142182295	R. CF 1/6W 8.2K J
R917	5130362303	R. MOF 1W 62K J	R965A	5142113495	R. CF 1/6W 130K J
R918	5142818295	R. CF 1/4W 1.8K J	R966	5142110295	R. CF 1/6W 1K J
R918A	5142122295	R. CF 1/6W 2.2K J	R968	5142843095	R. CF 1/4W 43 J
R920	5142810295	R. CF 1/4W 1K J	R969	5142868195	R. CF 1/4W 680 J
R921	5142415190	R. CF 1/2W 150 J	R969A	5142113295	R. CF 1/6W 1.3K J
R923	5142847090	R. CF 1/4W 47 J	R970	5142156295	R. CF 1/6W 5.6K J
R924	5142147090	R. CF 1/6W 47 J	R972	5142813395	R. CF 1/4W 13K J
R925	5142110295	R. CF 1/6W 1K J	R973	5142843095	R. CF 1/4W 43 J
R927	5142130195	R. CF 1/6W 300 J	R974	5142133295	R. CF 1/6W 3.3K
R928	5142151095	R. CF 1/6W 51 J	R976	5142810595	R. CF 1/4W 1M J
R929	5142110195	R. CF 1/6W 100 J	R976A	5142130395	R. CF 1/6W 30K J
R930	5130522903	R. MOF 3W 2.2 J	R977	5130362303	R. MOF 1W 62K J
R931	5142175095	R. CF 1/6W 75 J	R978	5142133295	R. CF 1/6W 3.3K
R934	5142833095	R. CF 1/4W 33 J	R981	5142110395	R. CF 1/6W 10K J
R935	5142182295	R. CF 1/6W 8.2K J	R982	5142110295	R. CF 1/6W 1K J
R935A	5142113495	R. CF 1/6W 130K J	R983	5142847095	R. 1/4W 47 J
R936	5142810295	R. CF 1/4W 1K J	R984	5142830395	R. CF 1/4W 30K J
R938	5142443090	R. CF 1/2W 43 J	R986	5142124395	R. CF 1/6W 24K J

RESISTOR

CKT NO	Part no.	Description
R987	5142120095	R. CF 1/6W 20 J
R988	5142120095	R. CF 1/6W 20 J
R991	5142139495	R. CF 1/6W 390K J
R992	5142139995	R. CF 1/6W 3.9 J
R993	5142110195	R. CF 1/6W 100 J
R994	5142110195	R. CF 1/6W 100 J
R995	5142856006	R. CF 1/4W 56 J
R996	5142136095	R. CF 1/6W 36 J
R997	5142136095	R. CF 1/6W 36 J
R998	5142136095	R. CF 1/6W 36 J

OTHER

CKT NO.	Part no.	Description
U901	5053102370	PCB PWB-0414-018/4
V901A	5056306721	CRT SOKET METALLO 033-0-7700-44 B10-301
Z901	5202202491	SPARK GAP MITSUBISHI DC300V 1PF DSP-301N-C04F
Z914 (RA)	5202201991	SPARK GAP DC200V 1PF DSP-201M-C04F
Z914 (RB)	5202201301	SPARK GAP DC200V 1PF GD412-200V-M
Z944 (RA)	5202201991	SPARK GAP DC200V 1PF DSP-201M-C04F
Z944 (RB)	5202201301	SPARK GAP DC200V 1PF GD412-200V-M
Z952 (RA)	5202200591	SPARK GAP 1-2KV 1PF
Z952 (RB)	5202200502	SPARK GAP 1-2KV 1PF
Z952 (RC)	5202200501	SPARK GAP SG05G 1KV 1PF
Z974 (RA)	5202201991	SPARK GAP DC200V 1PF DSP-201M-C04F
Z974 (RB)	5202201301	SPARK GAP DC200V 1PF GD412-200V-M

ASSEMBLY CRT

CKT NO.	Part no.	Description
V901 (CA)	5051286325	CCRT/DY M46QDG423X04 LG

Main PCB circuit(PWB-0404)

12. SCHEMATIC DIAGRAM

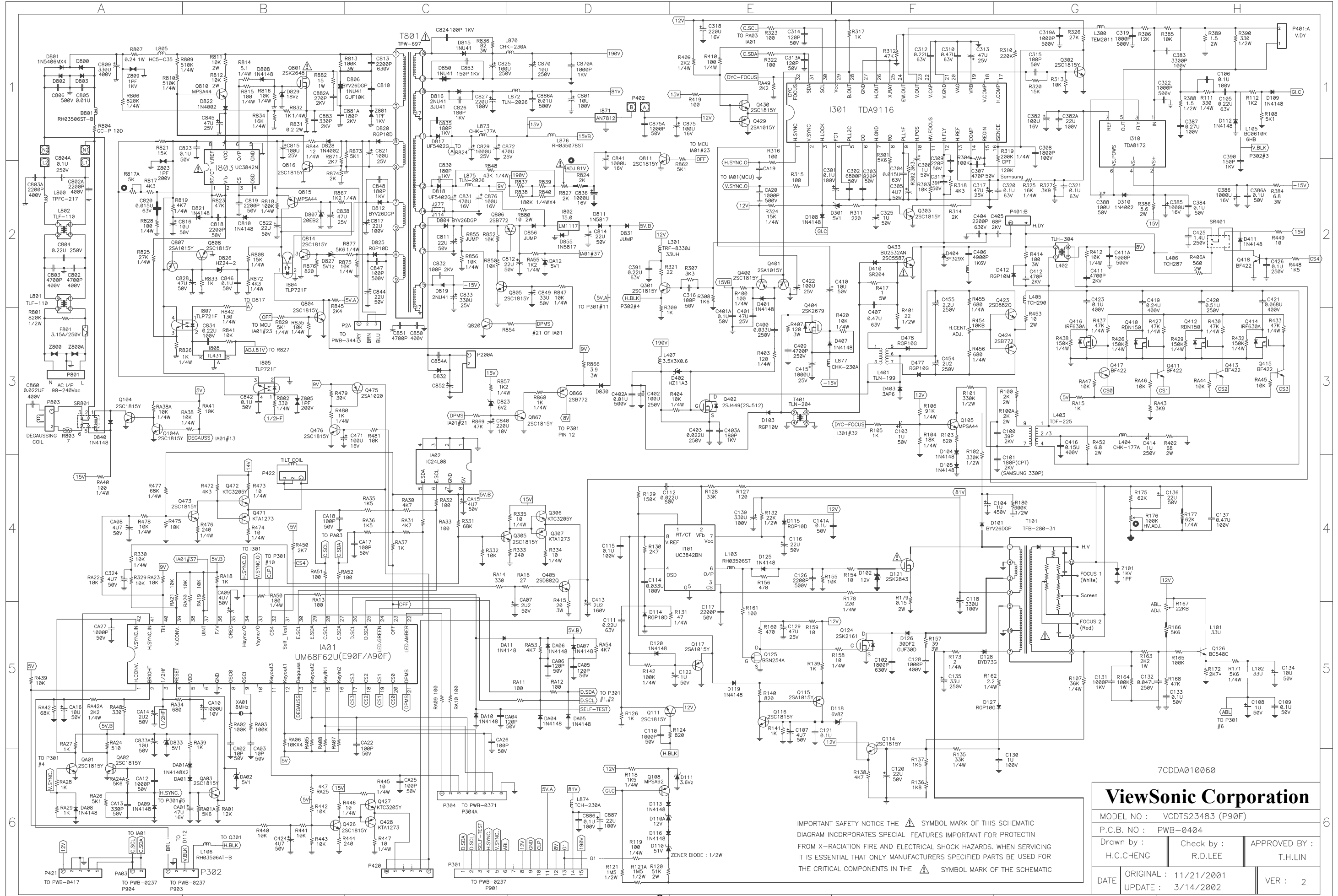

7CDDA010060

ViewSonic Corporation

MODEL NO : VCDS23483 (P90F)

P.C.B. NO : PWB-0404

Drawn by : H.C.CHENG Check by : R.D.LEE APPROVED BY : T.H.LIN

DATE ORIGINAL : 11/21/2001 VER : 2

UPDATE : 3/14/2002

IMPORTANT SAFETY NOTICE THE SYMBOL MARK OF THIS SCHEMATIC DIAGRAM INCORPORATES SPECIAL FEATURES IMPORTANT FOR PROTECTIN FROM X-RADIATION FIRE AND ELECTRICAL SHOCK HAZARDS. WHEN SERVICING IT IS ESSENTIAL THAT ONLY MANUFACTURERS SPECIFIED PARTS BE USED FOR THE CRITICAL COMPONENTS IN THE SYMBOL MARK OF THE SCHEMATIC

Video drive circuit(PWB-0414)

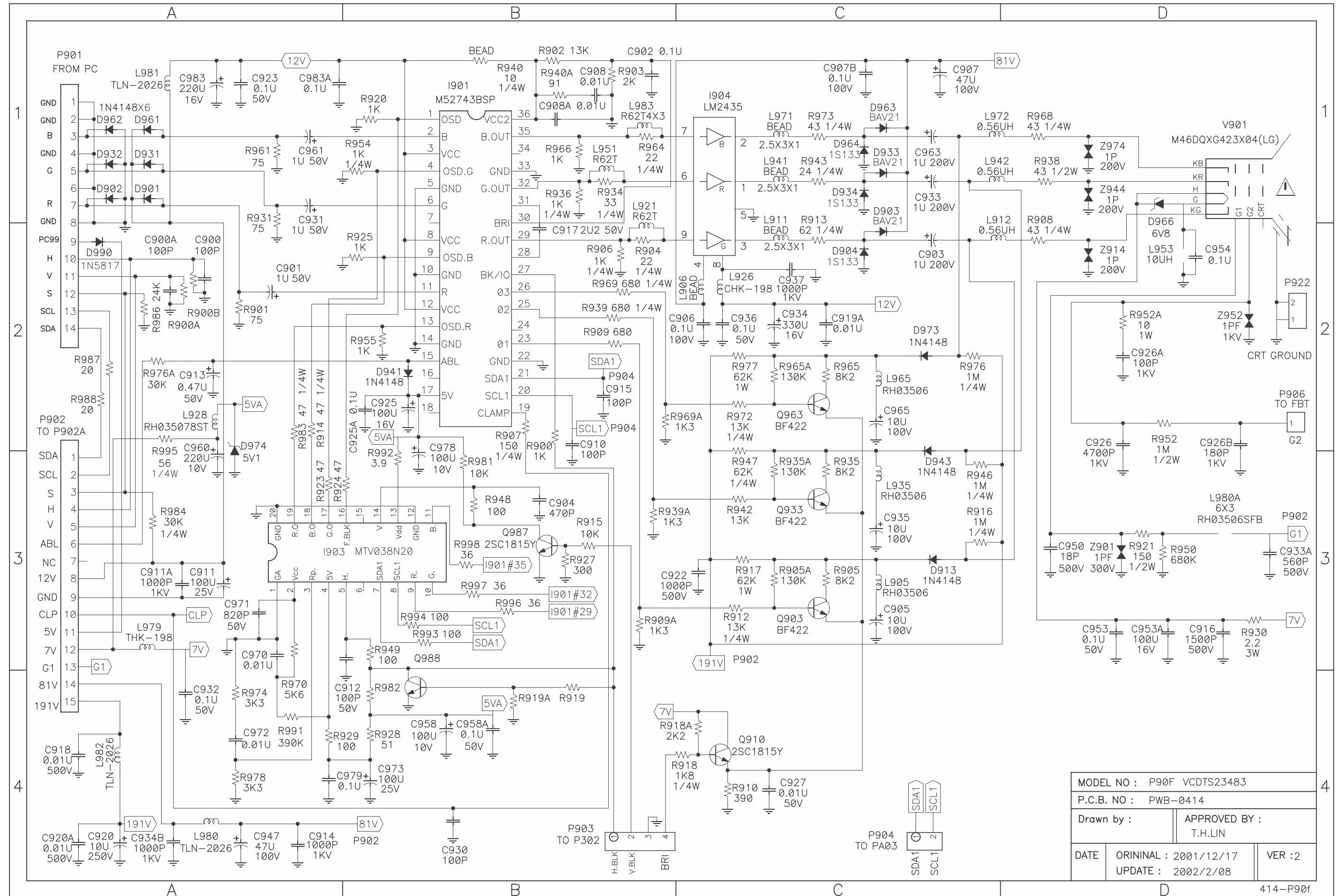

MODEL NO : P90F VCDTS23483		
P.C.B. NO : PWB-0414		
Drawn by :	APPROVED BY : T.H.LIN	
DATE	ORININAL : 2001/12/17 UPDATE : 2002/2/08	VER : 2

Purity Circuit (PWB-0417)

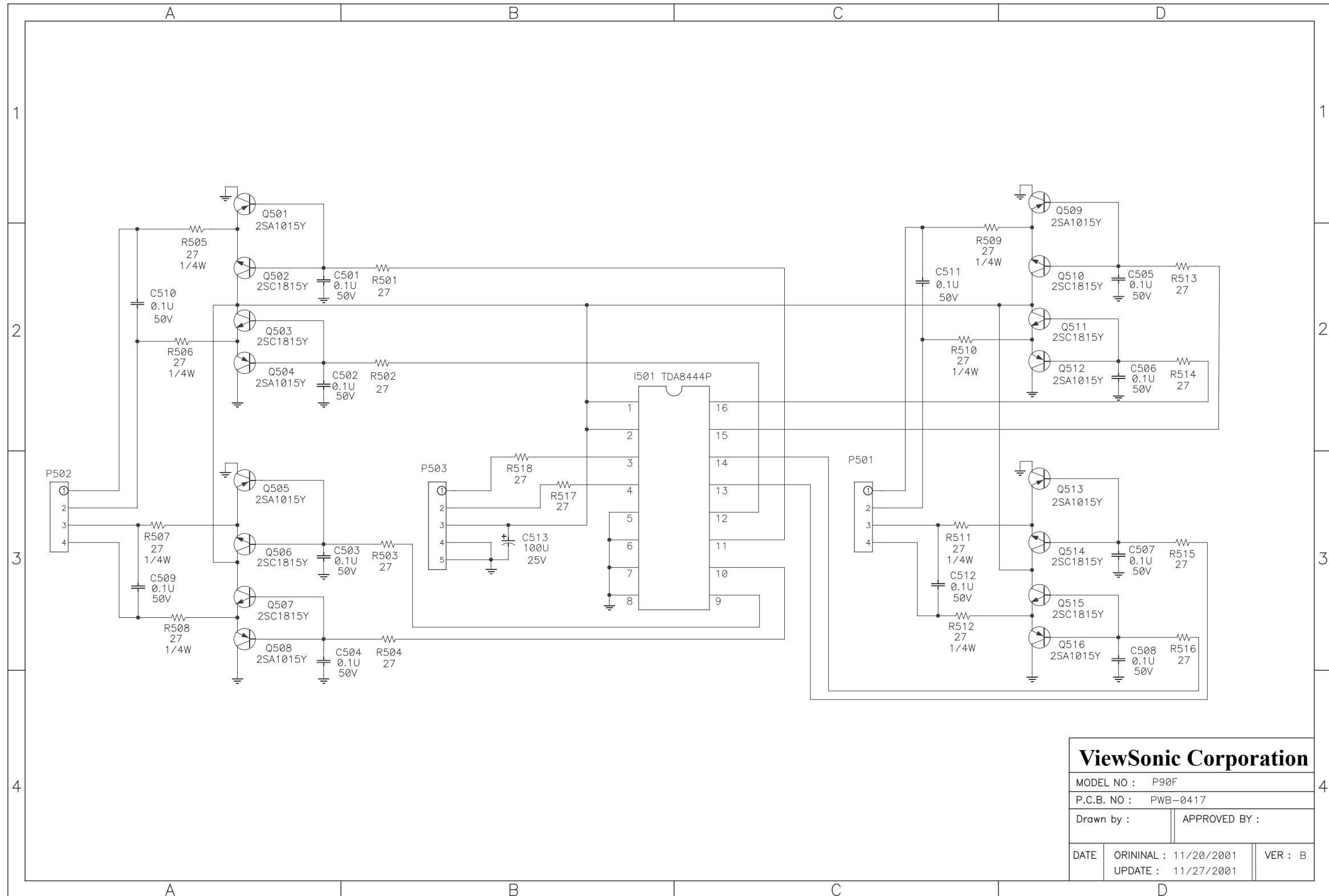

ViewSonic Corporation		
MODEL NO : P90F		
P.C.B. NO : PWB-0417		
Drawn by :	APPROVED BY :	
DATE	ORININAL : 11/20/2001	VER : B
	UPDATE : 11/27/2001	

PFC Circuit (PWB-0344)

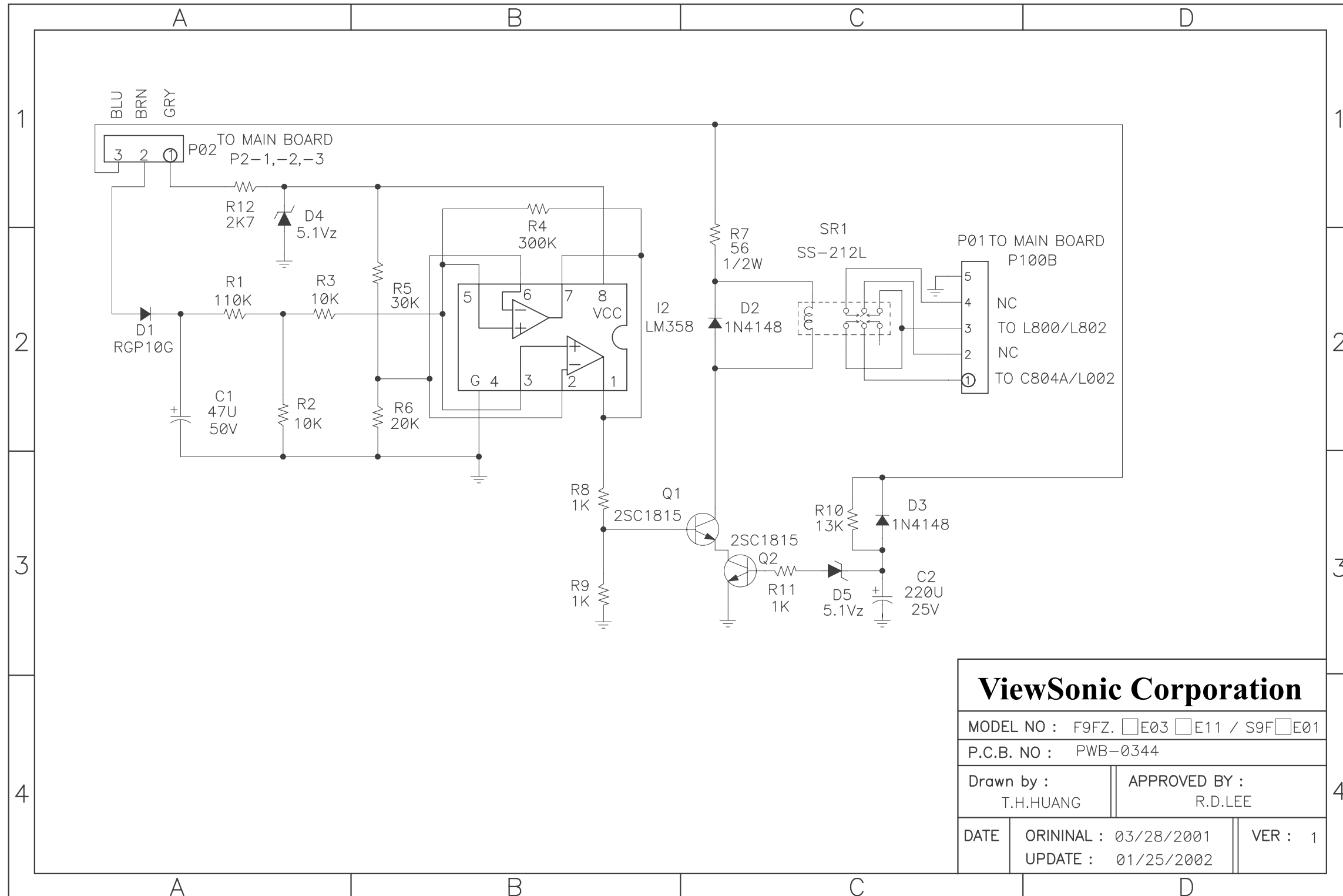

ViewSonic Corporation		
MODEL NO : F9FZ. <input type="checkbox"/> E03 <input type="checkbox"/> E11 / S9F <input type="checkbox"/> E01		
P.C.B. NO : PWB-0344		
Drawn by :	APPROVED BY :	
T.H.HUANG	R.D.LEE	
DATE	ORININAL : 03/28/2001	VER : 1
	UPDATE : 01/25/2002	

14. PCB LAYOUT

Main PCB circuit(PWB-0404)

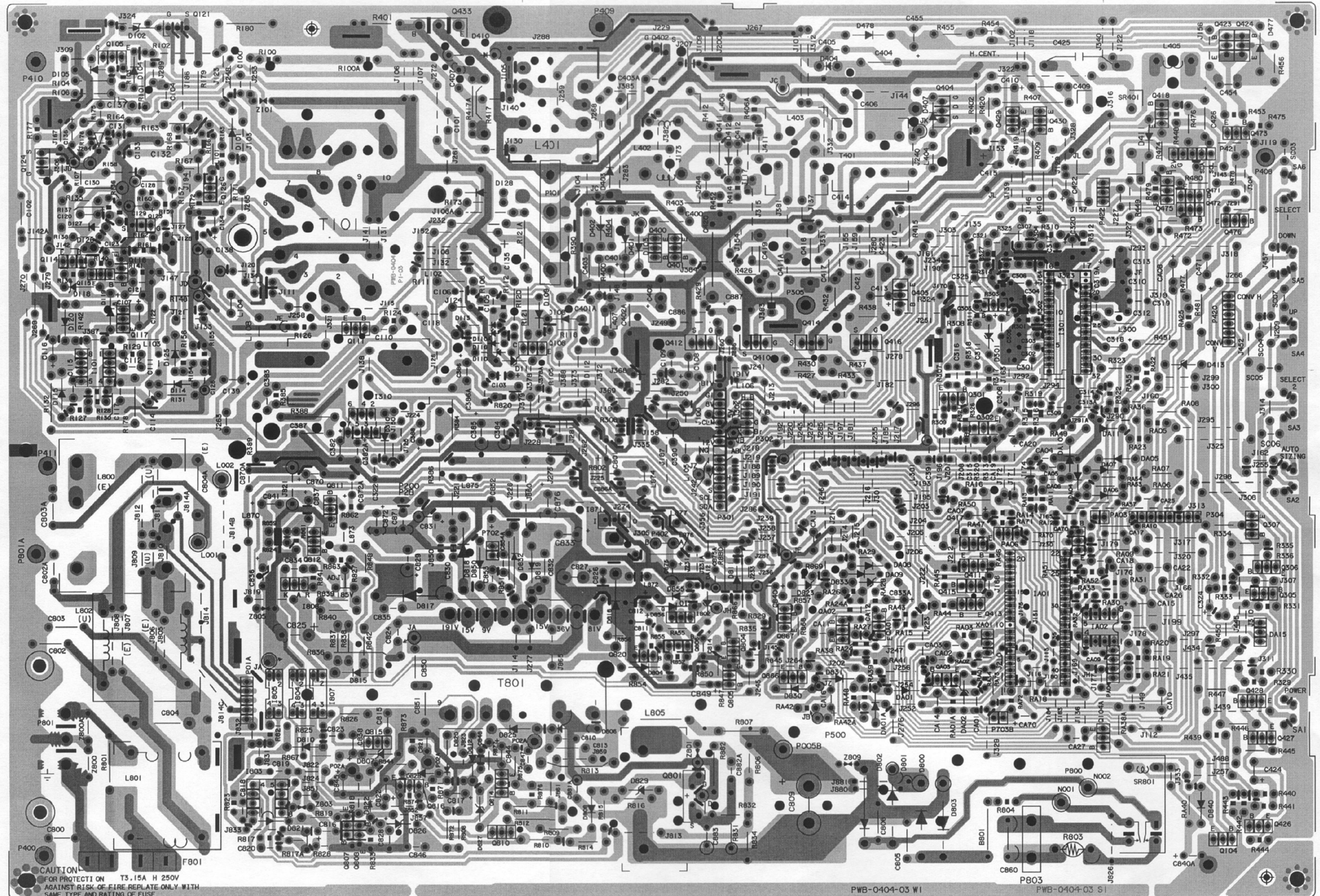

CAUTION
FOR PROTECTION ON T3.15A H 250V
AGAINST RISK OF FIRE REPLACE ONLY WITH
SAME TYPE AND RATING OF FUSE

PWB-0404-03 W1 PWB-0404-03 S1

Video drive circuit(PWB-0414)

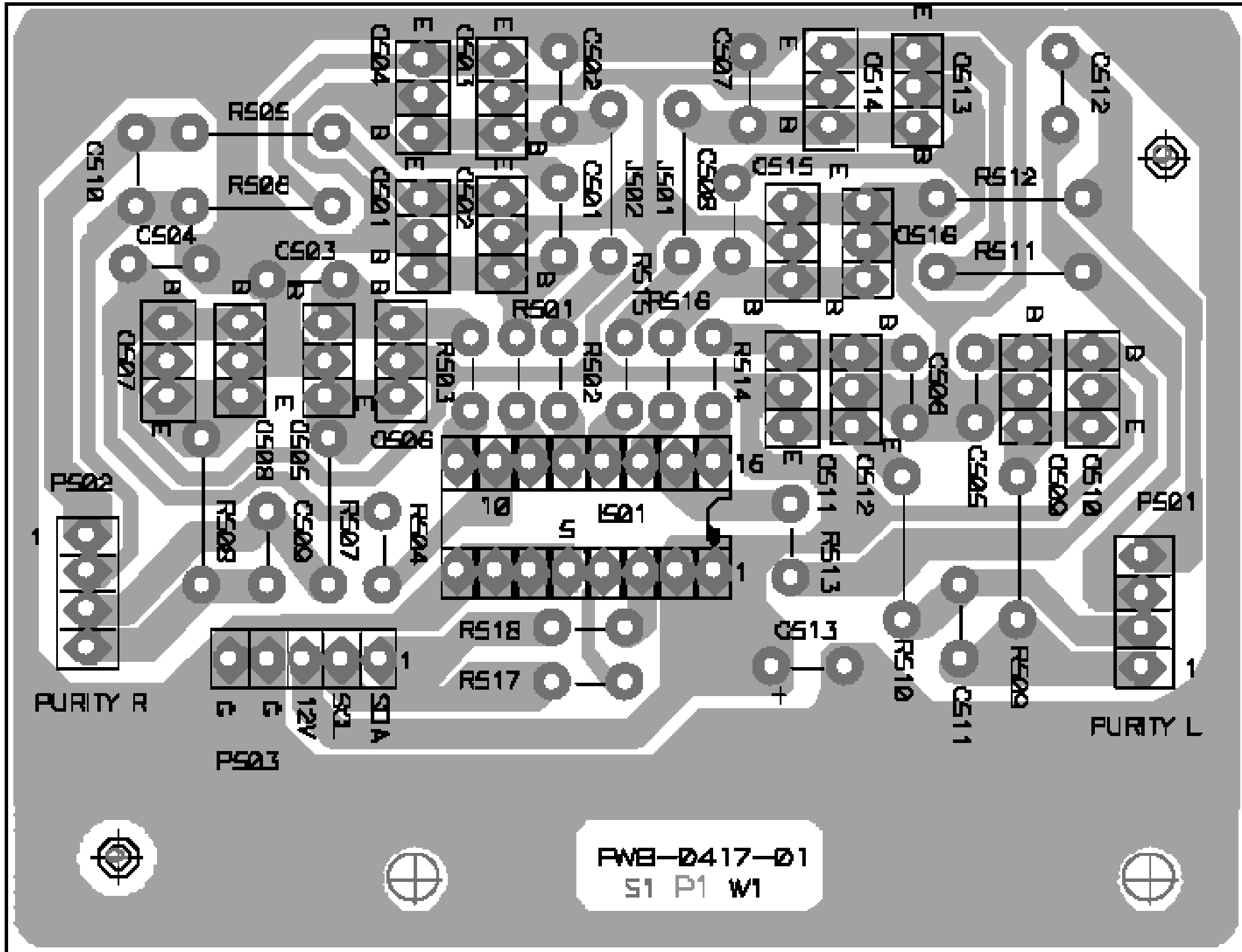

Purity Circuit (PWB-0417)

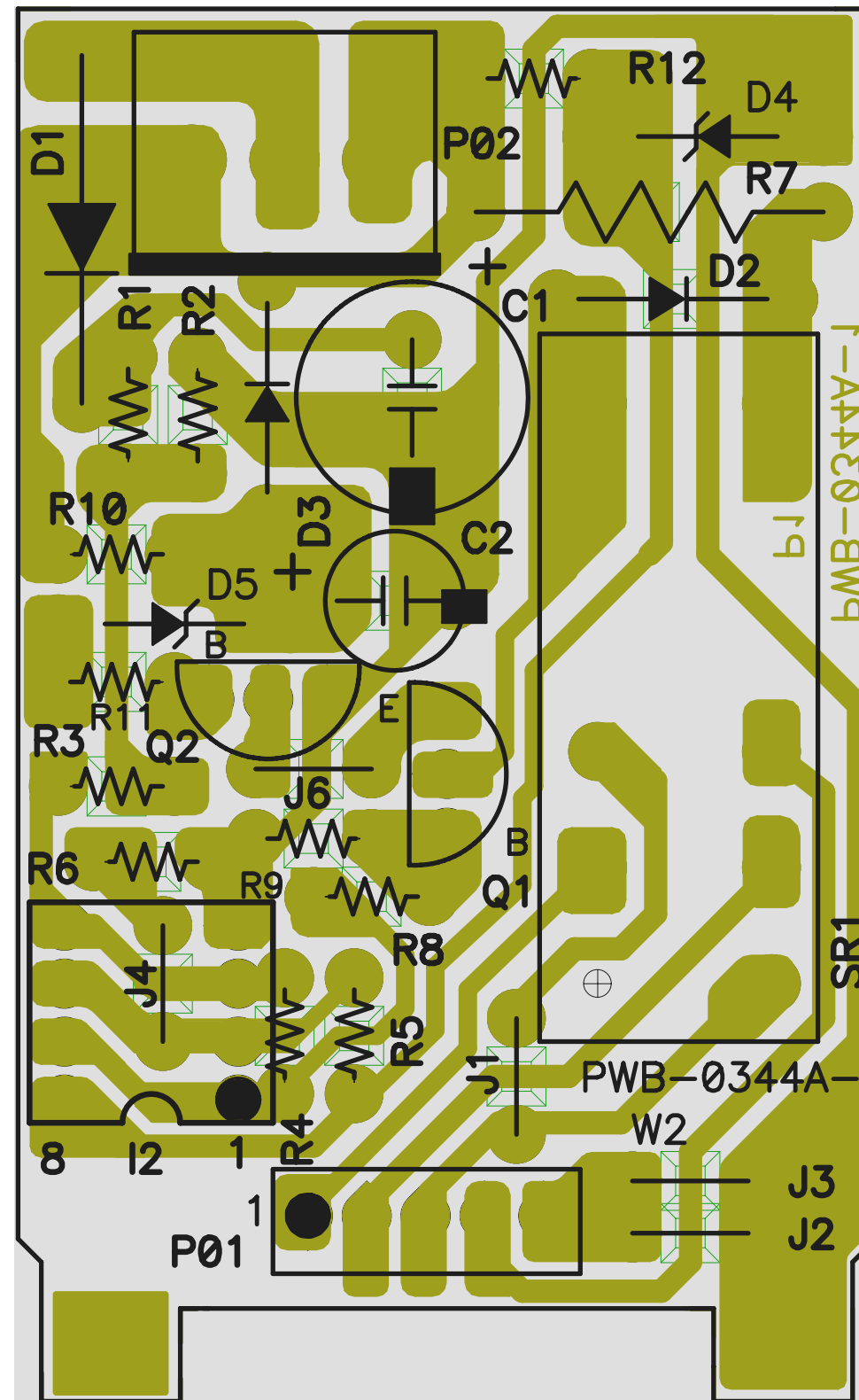

PFC Circuit (PWB-0344)

