

# **Service Manual**

## **ViewSonic PJ513D-1**

**Model No. VS11959**

**Multimedia DLP Projector**

**(PJ513D-1\_SM Rev. 1b May. 2009)**

---

**ViewSonic 381 Brea Canyon Road, Walnut, California 91789 USA - (800) 888-8583**

**Copyright**

Copyright © 2009 by ViewSonic Corporation. All rights reserved. No part of this publication may be reproduced, transmitted, transcribed, stored in a retrieval system, or translated into any language or computer language, in any form or by any means, electronic, mechanical, magnetic, optical, chemical, manual or otherwise, without the prior written permission of ViewSonic Corporation.

**Disclaimer**

ViewSonic makes no representations or warranties, either expressed or implied, with respect to the contents hereof and specifically disclaims any warranty of merchantability or fitness for any particular purpose. Further, ViewSonic reserves the right to revise this publication and to make changes from time to time in the contents hereof without obligation of ViewSonic to notify any person of such revision or changes.

**Trademarks**

Optquest is a registered trademark of ViewSonic Corporation.

ViewSonic is a registered trademark of ViewSonic Corporation.

All other trademarks used within this document are the property of their respective owners.

**Product disposal at end of product life**

The lamp in this product contains mercury. Please dispose of in accordance with local, state or federal laws.

# Revision History

Revision	SM Editing Date	ECR Number	Description of Changes	Editor
1a	12/17/2007		Initial Release	Jamie Chang
1b	05/12/2009		Update RS232 PIN definition, IR code	Sophia Kao

## TABLE OF CONTENTS

<b>1. Introduction</b>	<b>1</b>
<b>2. Specifications</b>	<b>2</b>
<b>3. Keyboard and Remote Control keys</b>	<b>15</b>
<b>4. IR Code / RS232 Command</b>	<b>18</b>
<b>5. Adjustment Procedure</b>	<b>22</b>
<b>6 Troubleshooting</b>	<b>82</b>
<b>7. Block Diagram</b>	<b>90</b>
<b>8 Schematic Diagrams</b>	<b>91</b>
<b>9. PCB Layout Diagrams</b>	<b>107</b>
<b>10. Exploded Diagrams</b>	<b>109</b>
<b>11. Recommended Spare Parts List</b>	<b>117</b>

# 1. Introduction

---

This section contains general service information, please read through carefully. It should be stored for easy access place.

## Important Service Information

### Safety Notice

- 1 Make sure your working environment is dry and clean, and meets all government safety requirements.
- 2 Ensure that other persons are safe while you are servicing the product.
- 3 DO NOT perform any action that may cause a hazard to the customer or make the product unsafe.
- 4 Use proper safety devices to ensure your personal safety.
- 5 Always use approved tools and test equipment for servicing.
- 6 Never assume the product's power is disconnected from the mains power supply. Check that it is disconnected before opening the product's cabinet.
- 7 Modules containing electrical components are sensitive to electrostatic discharge (ESD). Follow ESD safety procedures while handling these parts.
- 8 Some products contain more than one battery. Do not disassemble any battery, or expose it to high temperatures such as throwing into fire, or it may explode.
- 9 Refer to government requirements for battery recycling or disposal.

### General Descriptions

This Service Manual contains general information. There are 3 levels of service:

Level 1: Cosmetic / Appearance / Alignment Service

Level 2: Circuit Board or Standard Parts Replacement

Level 3: Component Repair to Circuit Boards

## 2. Specification

1.0 Optical Performance	Tested under 60" (diagonal) image size with Wide projection lens position unless other specified.	
1.1 ANSI Brightness	Minimum 1600 Lumens	
1.2 Brightness Uniformity		
1.2.1 ANSI Uniformity	Minimum 55%	
1.2.2 Upper-Down unbalance	0.5~2	
1.2.3 Left-Right unbalance	0.6~1.67	
1.2.4 JBMA Uniformity	Minimum 60%	
1.3 Contrast Ratio		
1.3.1 ANSI Contrast	Minimum 150:1	
1.3.2 FOFO Contrast	Minimum 1200:1	
1.4 Light Leakage		
1.4.1 Light Leakage in Active Area	<0.5 lux compared to center point within 60" (Diagonal at 2.2m, Wide) image size. Note: This light leakage in Active area is only described as the spot light with obvious shape. It is not included the uniformity difference of the projector for black pattern.	
1.4.2 Light Leakage out of Active Area	<0.65 lux with 54"~80"(Diagonal at 2m, Wide) image size	
1.5 Color		
	X	Y
1.5.1 White	0.312±0.04	0.354±0.04
1.5.2 Red	0.640±0.04	0.345±0.04
1.5.3 Green	0.355±0.04	0.548±0.04
1.5.4 Blue	0.141±0.04	0.087±0.04
1.6 Color Uniformity	X	Y
1.6.1 White	0.040	0.040
1.6.2 Red	0.040	0.040
1.6.3 Green	0.040	0.040
1.6.4 Blue	0.040	0.040
2.0 Image Quality		
2.1 Throw Ratio	54"±5% Diagonal at 2m, Wide	
2.2 Zoom Ratio (tolerance applied)	> 1.10 : 1	
2.3 Distortion		
2.3.1 Keystone Distortion	<1.0%	
2.3.2 Vertical TV Distortion	<1.0%	
2.3.3 Screen distortion	W2-W1   <6mm ,   H2 -H1   <6 mm	
2.4 Projection Offset	120% ±5%	
2.5 Focus Range		
2.5.1 Visible Range	1~8 m	

2.5.2 Clearly Focus Range	1.5~6 m(Spec. defined as item 2.6)		
2.6 Focus			
2.6.1 <input checked="" type="checkbox"/> Pattern	(1)If pattern can be uniformly focused, pass! (2)If not, check 2.6.2		
2.6.2 Defocus and Flare	Defocus: R<=3.0; G<=2.5; B<=2.5 pixel Flare: R<=4.0; G<=3.5; B<=3.5 pixel Slight flare is not counted as flare.		
2.6.3 Focus unbalance	Adjust focus from near to far until one corner clear, difference less than 70 cm@60"		
2.7 Lateral Color		Center of 49" diagonal area	All other area
	R-G	<2/3	<1
	G-B	<2/3	<1
	R-B	<1	<1
2.8 Image Quality			
2.8.1 DMD Image Quality	-		
2.8.2 Image Imperfection	-		
2.8.3 Image Shadow or Blur	<p>Procedure:</p> <ol style="list-style-type: none"> <li>54" (Diagonal at 2m, Wide) image size.</li> <li>Default preset mode " Dynamic"</li> <li>Full white pattern to check the image.</li> </ol> <p>Let the projector on the desk (don't move it up/down or left/ right) and just inspect the pattern.</p> <ol style="list-style-type: none"> <li>Compare to the limit sample of OOB. If blur or shadow worse than OOB, than NG</li> </ol>		
2.9 Dynamic Contrast Ratio (DCR)	<ol style="list-style-type: none"> <li>When RGB value of content input is smaller than 20%, system will automatically switch to Eco mode, if RGB value is greater than 60%, the projector will back to Normal mode.</li> <li>When DCR function turns on, lamp mode function is grayed out to disable; when DCR function turns off, lamp mode would return to setting value.</li> </ol>		
3.0 Mechanical Specification			
3.1 Dimensions	263 x 218 x 108mm (L x W x H)		
3.2 Weight	2.6Kgw ± 0.1Kgw		
3.3 Security Slot	Kensington compatible slot 150N break away force		
3.5 Lens Cover	Detached Lens Cover		
3.6 Feet	Fast adjustable foot in front, Adjustable foot and Fixed foot in rear. foot Tilt:0-6° ,right/left: +2.2° /-0.5°		
4.0 Packaging			
4.1 Outside Dimensions	370 x 186 x 297mm (L x W x H)		
4.2 Weight	3.76Kgw ± 0.1Kgw (Including Accessories, Projector).		

4.3 Palletization	72 units by Air; 108 units (pallet A)/72 units (pallet B) by sea 2232 units/40' container, or 1080 units /20' container	
5.0 Thermal Specification	Mechanical component temperature at ambience 0~40°C	
5.1 Surface held or touched for short periods	Normal surface: Metal < 60°C except screws & terminals Plastic<65°C except around ventilation (for this model only) Screw and terminals <55°C	
5.2 Surface which may be touched	Metal	Plastic
	<70°C	<95°C
5.3 Exhaust Air	<95°C around ventilation holes	
6.0 Environmental		
6.1 Temperature	Operating	0~40°C, without condensation
	Storage	-20~60°C, without condensation
6.2 Humidity	Operating	10~90%RH, without condensation
	Storage	10~90%RH, without condensation
6.3 Audible Noise Level	Typical	Normal mode: 32dBA @ 25°C Eco mode: 28dBA @ 25°C
	Maximum	Normal mode: 34BA @ 25°C Eco mode: 30dBA @ 25°C
6.4 Altitude	Operating: 0~6000ft, 25°C±5°C 6000ft~10000ft, 25°C±5°C must be operational and the reliability decrease is acceptable (not guarantee Power, Ballast, DMD and lamp life) Storage: 0 to +40000ft sea level(-20 °C to 30°C) Max altitude in 60°C :0-6500ft Max temperature in 10000ft:53°C	
7.0 Regulatory	Safety	CB, CSA, TUV-GS, CCC, PSB, NOM, Korean-eK, Gost-R, Hygiene, SASO, TUV-Argentina, Ukraine, CE
	EMC	FCC Class B requirements, CE
	ESD	Qisda ESD Specification
8.0 Reliability		
8.1 MTBF	40000 hours except DMD chip, Color wheel, Lamp and Ballast	
8.2 Lamp Lifetime	Normal : 2000 hours (50% brightness maintenance) Eco: 3000 hours	
9.0 Power Requirements	Adhere to Appendix 3.5	
9.1 Power Supply (Normal)	VAC 90 – 264 Auto-switch (50/60Hz), 3 Wire Grounded	
9.2 Power consumption	Typical	260 W Max.
	Standby	5W Max.

9.3 Power Connector	IEC-06
10.0 Panel Specification	
10.1 Type	Single Chip 0.55" XGA 12 tilt DDR DMD Single Chip 0.55" SVGA 12 tilt LVDS DMD
10.2 Pixels	800 X 600
10.3 Color Depth	24 Bits (16770000 colors)
11.0 Compatibility	Adhere to Appendix 3
11.1 PC	PC Compatible 640X480 → 800X600, compressed 1024 X 768 1280X1024; Composite-Sync; Sync-on-Green; Interlace Mode (8514A);
11.2 Video	NTSC/ NTSC4.43/ PAL (Including PAL-M, PAL-N)/ SECAM/ PAL60/
11.3 YpbPr	NTSC (480i)/ 480p/ PAL (576i)/ 576p, HDTV (720p/ 1080i)
11.4 DDC	DDC 2B
12.0 Image Interface	Adhere to Appendix 3.2
12.1 Analog RGB Input	15 pin D-Sub (Female) x 1 G(Y): Video amplitude 0.7/1.0 Vp-p : Impedance 75 RB(CbCr): Video amplitude 0.7 Vp-p : Impedance 75 HD/VD/CS: TTL Level
12.2 Video Input	RCA jack (Yellow) Video amplitude 1.0 Vp-p : Impedance 75Ω
12.3 S-Video Input	4 pin Mini-Din (Female) Y: Luminance amplitude 1.0 Vp-p : Impedance 75Ω C: Chroma amplitude 0.268 Vp-p : Impedance 75Ω
12.4 YPbPr Input	15 pin D-Sub (Female) x 1 (Including 12.1) Y: Luminance amplitude 1.0 Vp-p: Impedance 75Ω PbPr/CbCr: Chroma amplitude 0.7 Vp-p : Impedance 75Ω
12.5 DVI-A Input	N/A
12.6 Analog RGB Output	15 pin D-Sub (Female) x 1 G: Video amplitude 0.7/1.0 Vp-p : Impedance 75 RB: Video amplitude 0.7 Vp-p : Impedance 75 HD/VD/CS: TTL Level
13.0 Control Interface	
13.1 IR Receiver	IR Receiver x2 Angle: ±30° Distance 0~8m
13.2 Serial Connector	RS232 8pin Mini DIN
13.3 USB Connector	N/A
14.0 User Interface	Adhere to Appendix 3.3
14.1 Operator Keypad	9 Keys: Power ; Source ; Auto; Left/Blank; Right/Panel key lock ; Mode/Enter ; Up/Keystone+ ; Down/Keystone-; Menu/Exit
14.2 Indicators	3 LEDs: Power On/Off Status; Lamp Status; Temperature Status



14.3 Electric Keystone	vertical keystone and adjustable range 40
15.0 Audio	
15.1 Audio Input	Φ3.5mm stereo mini jack x1 500mVrms, 10kΩ
15.2 Speaker	Sound system: Mono
	Speaker : 2Wx1
	Amplifier: Philips PCA8551
	Frequency Response: 100-20KHz
	Distortion: Amplifier output 1W at 10% distortion
15.3 Audio Output	N/A
16.0 Option Box	
16.1 Wireless function	N/A
16.2 Audio Output	N/A
16.3 LAN function	N/A

**DDC Table (EDID FILE)**

	+0	+1	+2	+3	+4	+5	+6	+7	+8	+9
0	00	FF	FF	FF	FF	FF	FF	00	5A	63
10	20	C5	01	01	01	01	01	11	01	03
20	7A	00	00	78	0A	F1	A7	A5	56	5D
30	88	23	15	52	59	AD	CE	00	45	59
40	31	59	61	59	81	80	01	01	01	01
50	01	01	01	01	A0	0F	20	00	31	58
60	1C	20	28	80	14	00	00	00	00	00
70	00	1E	00	00	00	FF	00	51	54	59
80	30	37	30	31	30	30	30	30	31	0A
90	00	00	00	FD	00	32	57	1E	64	FF
100	00	0A	20	20	20	20	20	20	00	00
110	00	FC	00	50	4A	35	31	33	44	0A
120	20	20	20	20	20	20	00	51		

Address	Data description																
00 - 07	Fixed Data(EDID header)																
08 - 09	ID Manufacturer Name: VSC = 5Ah 63h (Alphabet number transformed to hex scale from binary)																
10 - 11	ID Product Code: 20h, C5h																
12 - 15	Not Used																
16	Week of Manufacture: 01 (for example; variable)																
17	Year of Manufacture: 2007 (for example; variable)																
18	EDID Structure Version No.: 1																
19	EDID Structure Revision No.: 3																
20	Video Input Definition: Analog Signal 0.700V/0.000V Sync: Separate <input type="checkbox"/> Composite <input checked="" type="checkbox"/> On Green <input checked="" type="checkbox"/> Set up <input type="checkbox"/> Serration <input type="checkbox"/>																
21 - 22	Maximum Horizontal Image Size: 0cm      Maximum Vertical Image Size: 0cm																
23	Display Gamma: 2.2																
24	DPMS Supported Feature: Stand by <input type="checkbox"/> Suspend <input type="checkbox"/> Active off <input type="checkbox"/> Display Type: R/G/B color display Standard Default Color Space: unused Preferred Timing Mode: supported GTF supported: not supported																
25 - 34	Chroma Information: <table border="1" style="width:100%; border-collapse: collapse;"> <tr> <td style="width:33%;">Red</td> <td style="width:33%;">x = 0.634766</td> <td style="width:33%;">y = 0.338867</td> </tr> <tr> <td>Green</td> <td>x = 0.368164</td> <td>y = 0.544922</td> </tr> <tr> <td>Blue</td> <td>x = 0.147461</td> <td>y = 7.51953e-002</td> </tr> <tr> <td>White</td> <td>x = 0.313477</td> <td>y = 0.34375</td> </tr> </table>	Red	x = 0.634766	y = 0.338867	Green	x = 0.368164	y = 0.544922	Blue	x = 0.147461	y = 7.51953e-002	White	x = 0.313477	y = 0.34375				
Red	x = 0.634766	y = 0.338867															
Green	x = 0.368164	y = 0.544922															
Blue	x = 0.147461	y = 7.51953e-002															
White	x = 0.313477	y = 0.34375															
35	Established Timing I Support: <table border="1" style="width:100%; border-collapse: collapse;"> <tr> <td style="width:25%;">720X400 @70Hz</td> <td style="width:5%;"><input checked="" type="checkbox"/></td> <td style="width:25%;">720X400 @88Hz</td> <td style="width:5%;"><input type="checkbox"/></td> <td style="width:25%;">640X480 @60Hz</td> <td style="width:5%;"><input checked="" type="checkbox"/></td> <td style="width:25%;">640X480 @67Hz</td> <td style="width:5%;"><input type="checkbox"/></td> </tr> <tr> <td>640X480 @72Hz</td> <td><input checked="" type="checkbox"/></td> <td>640X480 @75Hz</td> <td><input type="checkbox"/></td> <td>800X600 @56Hz</td> <td><input type="checkbox"/></td> <td>800X600 @60Hz</td> <td><input checked="" type="checkbox"/></td> </tr> </table>	720X400 @70Hz	<input checked="" type="checkbox"/>	720X400 @88Hz	<input type="checkbox"/>	640X480 @60Hz	<input checked="" type="checkbox"/>	640X480 @67Hz	<input type="checkbox"/>	640X480 @72Hz	<input checked="" type="checkbox"/>	640X480 @75Hz	<input type="checkbox"/>	800X600 @56Hz	<input type="checkbox"/>	800X600 @60Hz	<input checked="" type="checkbox"/>
720X400 @70Hz	<input checked="" type="checkbox"/>	720X400 @88Hz	<input type="checkbox"/>	640X480 @60Hz	<input checked="" type="checkbox"/>	640X480 @67Hz	<input type="checkbox"/>										
640X480 @72Hz	<input checked="" type="checkbox"/>	640X480 @75Hz	<input type="checkbox"/>	800X600 @56Hz	<input type="checkbox"/>	800X600 @60Hz	<input checked="" type="checkbox"/>										
36	Established Timing II Support: <table border="1" style="width:100%; border-collapse: collapse;"> <tr> <td style="width:25%;">800X600 @72Hz</td> <td style="width:5%;"><input checked="" type="checkbox"/></td> <td style="width:25%;">800X600 @75Hz</td> <td style="width:5%;"><input checked="" type="checkbox"/></td> <td style="width:25%;">832X624 @75Hz</td> <td style="width:5%;"><input type="checkbox"/></td> <td style="width:25%;">1024X768 @87Hz</td> <td style="width:5%;"><input type="checkbox"/></td> </tr> <tr> <td>1024X768 @60Hz</td> <td><input checked="" type="checkbox"/></td> <td>1024X768 @70Hz</td> <td><input checked="" type="checkbox"/></td> <td>1024X768 @75Hz</td> <td><input checked="" type="checkbox"/></td> <td>1280X1024 @75Hz</td> <td><input type="checkbox"/></td> </tr> </table>	800X600 @72Hz	<input checked="" type="checkbox"/>	800X600 @75Hz	<input checked="" type="checkbox"/>	832X624 @75Hz	<input type="checkbox"/>	1024X768 @87Hz	<input type="checkbox"/>	1024X768 @60Hz	<input checked="" type="checkbox"/>	1024X768 @70Hz	<input checked="" type="checkbox"/>	1024X768 @75Hz	<input checked="" type="checkbox"/>	1280X1024 @75Hz	<input type="checkbox"/>
800X600 @72Hz	<input checked="" type="checkbox"/>	800X600 @75Hz	<input checked="" type="checkbox"/>	832X624 @75Hz	<input type="checkbox"/>	1024X768 @87Hz	<input type="checkbox"/>										
1024X768 @60Hz	<input checked="" type="checkbox"/>	1024X768 @70Hz	<input checked="" type="checkbox"/>	1024X768 @75Hz	<input checked="" type="checkbox"/>	1280X1024 @75Hz	<input type="checkbox"/>										

37	Established Timing III Support: Reserved - Reserved - Reserved - Reserved Reserved - Reserved - Reserved - Reserved
38 - 53	Standard Timing Identification: #1 60X480 @85Hz      #2 800X600 @85Hz      #3 1024X768 @85Hz      #4 1280X1024 @60Hz #5 Non-Description      #6 Non-Description      #7 Non-Description      #8 Non-Description
54 - 125	Descriptor Description
54 - 71	Detailed Timing Description #1:      800x600 @60Hz      Pixel Clock = 40.00 MHz Horizontal Image Size = 0 mm      Vertical Image Size = 0 mm Refresh mode: Non Interlaced      Normal display, no stereo Horizontal Active Time = 800 pixels      Blanking Time = 256 pixels Sync Offset = 40 pixels      Sync Pulse Width = 128 pixels Border = 0 pixels      Frequency = 37.88 kHz Vertical Active Time = 600 lines      Blanking Time = 28 lines Sync Offset = 1 lines      Sync Pulse Width = 4 lines Border = 0 lines      Frequency = 60 Hz Sync configuration: Digital Separate V sync: NEGA H sync: NEGA
72 - 89	Serial Number  (Each word to be transformed in ASCII code)
90 - 107	Monitor Description Monitor Range Limits: Vertical Frequency (min.) = 50Hz Vertical Frequency (max.) = 87 Hz Horizontal Frequency (min.) = 30 kHz Horizontal Frequency (max.) = 100 kHz Maximum Supported Pixel Clock = 110 MHz GTF Standard is unused.
108 - 125	Monitor Description Monitor Name: PJ513D
126	Extension Flag: 0
127	Checksum: 51 (for example; variable)

## Screw List /Torque

Model name : PJ513D									
	No.	Screw P/N	Description				Q'TY	Torque (kgf-cm)	Where use
			Type	Head	Length	Coating			
M2.0	1	8F.1A522.6R0	MACH	PHM	6	NI	1	2.5±0.5	Holder adjust foot & Fix block (1*)
M3.0	2	8F.1G524.5R0	MACH	CAP	5	NI	1	4.5±0.5	Engine HSG & Power BD Shielding (1*)
	3	8F.VA564.6R0	TAP (D-PT)	PHM	6	NI	12	5.5±0.5	Blower BKT BTM & Lower Case(2*)
									Ballast & Lower Case(3*)
									Power Board S/W & Lower Case(2*)
									Lamp Box & Lower Case(2*)
								5.5±0.5	Ceiling Mount Plate & Lower Case(3*)
	4	8F.1A524.6R0	MACH	PHM	8	NI	2	4.5±0.5	Lamp Door & Lower Case (2*)
	5	8F.1A524.5R0	MACH	PHM	5	NI	8	4.5±0.5	Blower BKT & Nozzle(1*)
									Main BD Shielding & Power BD Shielding(5*)
									Speaker & Rear Cover (2*)
6	8F.VA564.100	TAP (D-PT)	PHM	10	NI	4	7.5±0.5	Upper Case & Lower Case(4*)	
7	8F.VG19.8R0	TAP	CAP	8	NI	3	7.0±0.5	Lower Case & Power BD Shielding (3*)	
8	8F.VA564.8R0	TAP (D-PT)	PHM	8	NI	3	6.0±0.5	Engine HSG & Lower Case(3*)	
9	8G.00020.423	NUT	HEX	3	NI	1	2.5±0.5	Rear adjust foot top(1*)	
M4.0	10	8F.1D526.6R0	MACH	TAPTILE	8	NI	4	5.5±0.5	AC Wire & Power BD Shielding(1*)
									Ceiling Mount Plate & Lower Case(3*)
#4-40	11	8F.00480.120	MACH	STAND	8	NI	4	4.5±0.5	Rear Case & D-SUB(4*)

## 1. Timing Table

The Default timing is as following:

Resolution	Mode	Refresh rate (Hz)	H-frequency (kHz)	Clock (MHz)
720 x 400	720x400_70	70.087	31.47	28.322
640 x 480	VGA_60	59.940	31.469	25.175
	VGA_72	72.809	37.861	31.500
	VGA_75	75.000	37.500	31.500
	VGA_85	85.008	43.269	36.000
800 x 600	SVGA_60	60.317	37.879	40.000
	SVGA_72	72.188	48.077	50.000
	SVGA_75	75.000	46.875	49.500
	SVGA_85	85.061	53.674	56.250
1024 x 768	XGA_60	60.004	48.363	65.000
	XGA_70	70.069	56.476	75.000
	XGA_75	75.029	60.023	78.750
	XGA_85	84.997	68.667	94.500
1280 x 1024	SXGA3_60	60.020	63.981	108.000

YPbPr support timing is as following:

Signal format	fh(kHz)	fv(Hz)
480i(525i)@60Hz	15.73	59.94
480p(525p)@60Hz	31.47	59.94
576i(625i)@50Hz	15.63	50.00
576p(625p)@50Hz	31.25	50.00
720p(750p)@60Hz	45.00	60.00
720p(750p)@50Hz	37.50	50.00
1080i(1125i)@60Hz	33.75	60.00
1080i(1125i)@50Hz	28.13	50.00

Video, S-Video support timing is as following:

Video mode	fh(kHz)	fv(Hz)	fsc(MHz)
NTSC	15.73	60	3.58
PAL	15.63	50	4.43
SECAM	15.63	50	4.25 or 4.41
PAL-M	15.73	60	3.58
PAL-N	15.63	50	3.58
PAL-60	15.73	60	4.43
NTSC4.43	15.73	60	4.43

## 2. Characteristics of inputs/outputs

Signal	Parameter	Min	Type	Max	
RDATA GDATA BDATA	Impedance		75		Ohm
	Amplitude		0.7		Volts peak-to-peak
	Black pedestal		0		Volts
	Pixel Clock		110		M Hz
GDATA_SOG	Impedance		75		Ohm
	Amplitude		1		Volts peak-to-peak
	Video amplitude		0.7		Volts peak-to-peak
	Sync amplitude		0.3		Volts peak-to-peak
	Black pedestal		0		Volts
	Pixel Clock		110		M Hz
HDATA	Impedance		1		K ohm
	Amplitude, low level	0		0.8	volt
	Amplitude, high level	2.5		5	Volt
	Frequency	31		82	K Hz
VDATA	Impedance		1		K ohm
	Amplitude, low level	0		0.8	volt
	Amplitude, high level	2.5		5	Volt
	Frequency	48		85	Hz
SDADATA	Amplitude, low level	0		0.8	volt
	Amplitude, high level	2.5		5	Volt
SCLDATA	Amplitude, low level	0		0.8	volt
	Amplitude, high level	2.5		5	Volt
RXD	Amplitude	-25		25	Volt
TXD	Amplitude	-25		25	Volt
CVBS Luminance	Amplitude, total (video+ sync)		1		Volts peak to peak
	Amplitude, video		0.7		Volts peak to peak
	Amplitude, sync		0.3		Volts peak to peak
	Impedance		75		ohm
CVBS Chroma	Amplitude		300		m Volts peak to peak
	Impedance		75		ohm
Audio	Impedance (audio in)		10		Kohm
	Amplitude (audio in)	0		0.30	Volts rms
	Bandwidth	300Hz		16kHz	
	S/N Ratio		40		%
	Total Harmonic Distortion			10	%

### 3. Electrical Interface Character

#### Interface Definition

- 15 pin definition of the mini D-sub male for DDC2B protocol

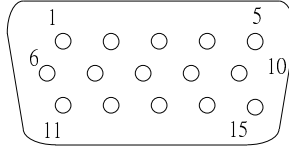

Pin	Definition	Pin	Definition	Pin	Definition	Pin	Definition
1	Red video (Pr)	2	Green Video (Y)	3	Blue Video (Pb)	4	NC
5	NC	6	Red Video Return	7	Green Video Return	8	Blue Video Return
9	NC	10	Sync. Return	11	Monitor ID bit 0	12	Bi-directional data (SDA)
13	Horizontal Sync	14	Vertical Sync	15	Data clock (SCL)		

- Video Input

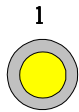

Composite input

Pin	Definition
1	Composite video input

- S-Video input

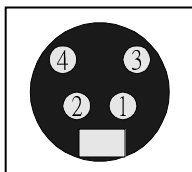

Pin	Description
1	GND
2	GND
3	Luminance
4	Chroma

- Control Port

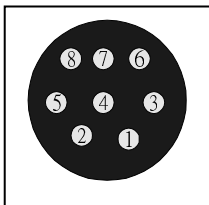

RS232 cable :

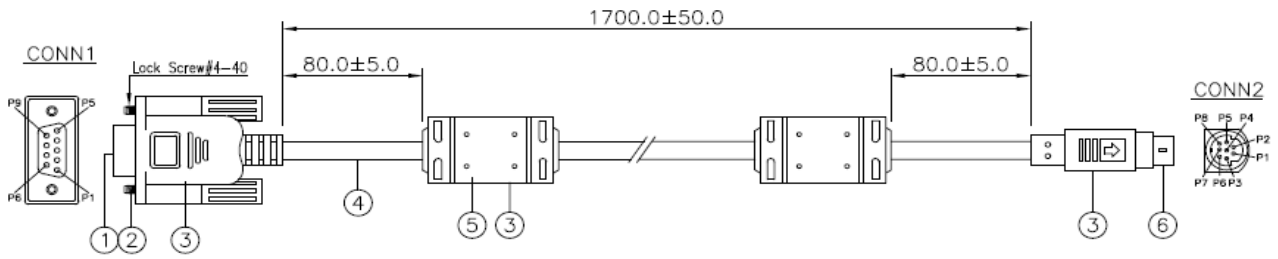

PC side		COLOR of Wire	Projector side	
CONN1	Function name		CONN2	Function name
3	TXD	Black	1	RXD
7	RTS	Brown	2	CTS
4	NC	Red	3	NC
5	GND	Orange	4	GND
8	CTS	Yellow	5	RTS
1	NC	Green	6	NC
2	RXD	Blue	7	TXD
9	NC	White	8	NC
6	NC			



#### 4. Functionality

The Following functionality will be supported: (Detailed description refer to SW Specification)

Functionality	Data (Computer)	Video/S-Video	YPbPr/YCbCr
Preset Mode	YES	YES	YES
Brightness	YES	YES	YES
Contrast	YES	YES	YES
Color	NO	YES	YES
Tint	NO	YES	YES
Sharpness	NO	YES	NO
Color Temp	YES	YES	YES
H. Position	YES	NO	YES
V. Position	YES	NO	YES
H. Phase	YES	NO	YES
H. Size	YES	NO	YES
Keystone	YES	YES	YES
Language	YES	YES	YES
Auto	YES	YES	YES
Image Ratio	YES	YES	YES
Auto Off	YES	YES	YES
Mirror	YES	YES	YES
Source	YES	YES	YES
Freeze	YES	YES	YES
Blank	YES	YES	YES
Lamp Reset	YES	YES	YES
OSD Timer	YES	YES	YES
Source Scan	YES	YES	YES
Keystone Hold	YES	YES	YES
Mirror Hold	YES	YES	YES
Blank Time	YES	YES	YES
Information	YES	YES	YES
Reset	YES	YES	YES

External Message indicator (Detailed description refer to SW Specification)

Message	Occasion
PC/Composite Video /S-Video /Analog YPbPr Searching	The system does not detect the signal
Out of range	The signal is over the specification
NOTICE :Order replacement lamp , Lamp > 2000 hours	Lamp Hour is over 2000 hours
NOTICE: Replacement lamp soon, Lamp > 2950 Hours	Lamp Hour is over 2950 hours
NOTICE: Replacement lamp Now, Lamp > 3000 Hours, Lamp-usage time exceeded.	Lamp Hour is over 3000 hours.

## 5 Power Supply Specification

### 5.1. Input Power Specification

Specification	Description
Input Voltage Range	The unit shall meet all the operating requirements with the range 90 ~ 264 VAC
Frequency Range	The unit shall meet all the operating requirements with an input frequency range 50 Hz ~ 60 Hz
Power Consumption	Normal operation: 260 W (Max) standby mode: < 5 W
Regulation Efficiency	80 % (typical) measuring at 115Vac and full load

### 5.2. Output Power Requirement

The power supply can provide DC output as below :

NO.	Voltage	Regulation	Load Current Range	Ripple & Noise
1	+5 V	±5 %	0.06A ~ 0.5 A	100 mV
2	+12 V	±10 %	0.04 A ~ 1.25A	300 mV

### 5.3. Lamp Power specifications

Specification	Description
Applicable Lamp	180W, AC operation
Starting pulse from Ignitor	2.5KV

### 5.4. Others

Item	Description
Power good signal	Active high after 5 Volt reach 95% of its rating and goes to logic low at least 0.5ms before power falls to 90% of its rating
High voltage and high temperature protection	To avoid user from the dangerous of HV and high temperature, when front door of lamp case is opened whether intentionally or accidentally, the power should be disconnected immediately. When the door is closed again, the igniter restart sequence should be compliant to that is described previously

### 3. Keyboard and Remote Control keys

#### Local Keyboard Description

Key Name	Detailed Description
Power	Use this button to turn your Data Projector on and off (standby mode).
Source	To select input sources as Computer, Video, S-Video, YpbPr
Auto	Toggle auto-tracking image function
Left/Blank	<ol style="list-style-type: none"><li>1. When user presses the button once, the image would turn to blank and show "blank" in the right-button screen.</li><li>2. When the image is blank, user press this key back to Normal image; if user presses other buttons on keypad or remove, it would release</li><li>3. If there is OSD menu, user can press this key to move to the left item.</li></ol>
Right/Panel Key	<ol style="list-style-type: none"><li>1. When user presses the button once, it will enter "Panel key Lock" setting.</li><li>2. When panel key is locked, user could press this key for 3 seconds to release Panel Key Lock( If the panel key lock is active, user still could use power key to turn on/off the projector)\</li><li>3. When there is OSD menu, user can press this key to move to the right item</li></ol>
Up/Keystone+	<ol style="list-style-type: none"><li>1. When user presses this button once, it will increase the keystone value.</li><li>2. When there is OSD menu, user can press this key to move to upper item.</li></ol>
Down/Keystone-	<ol style="list-style-type: none"><li>1. When user presses this button once, it will decrease the keystone value.</li><li>2. When there is OSD menu, user can press this key to move to next item.</li></ol>
Menu/Exit	<ol style="list-style-type: none"><li>1. User could press this button to call OSD</li><li>2. When it exists OSD, user could press this button to leave current page to main menu or to close OSD.</li></ol>
Mode/Enter	<ol style="list-style-type: none"><li>1. When there is No OSD menu, this button is Mode hot key; user would press this button to choose one of preset modes.</li><li>2. When there is confirm messages, user could press this key to confirm selection.</li></ol>

## Remote Control Keys Description

IR-Key Name	Detailed Description
Power	Use this button to turn your Data Projector on and off (standby mode).
Source	To select input sources as Computer, YPbPr , Video, S-Video
Menu/Exit	(1) OSD pop-up. (2) Close OSD or leave current page
▶ /Panel Key	(1) Press once, enter "Panel Key Lock" setting. (2) Press 3 seconds to release "Panel Key Lock". (3) OSD menu, move to right items
◀	(1) OSD menu, move to left item.
▲ /Keystone+	(1) Keystone+. (2) Move to page level
▼ /Keystone-	(1) Keystone-. (2) Move item bar
Auto	Toggle auto-tracking image function
Mode/Enter	(1) Change different Preset mode (2) Press for confirm message.
Freeze	This button will freeze a picture. Press again to resume motion.
Blank	Press "Blank" key first to blank the screen.
Digital Zoom +	(1) Zoom in (2) Pan the picture , when picture is in Zoom in/out image.
Digital Zoom -	(1) Zoom out (2) Pan the picture, when picture is in Zoom in/out image.

## External Status indicator

LED Name	Detailed Description
Power LED	Display the power on/off sequence status
Lamp Status LED	Display the Lamp status (Lamp fail, Lamp spoil etc.)
Temperature Status LED	Display the Thermal status (Fan Fail, Over Temperature, etc.)

## 4. IR Code / RS232 Command

### 1. IR Code

CUSTOMER CODE	DATA CODE	FUNCTION
0030	02	POWER
0030	03	II/▶
0030	04	SOURCE
0030	05	TIMER (ON)
0030	06	TIMER (SETUP)
0030	07	BLANK
0030	08	AUTO
0030	0B	▲
0030	0C	▼
0030	0D	◀
0030	0E	▶
0030	0F	MENU
0030	10	MODE
0030	18	DIGITAL ZOOM +
0030	19	DIGITAL ZOOM -

### 2. RS-232 Command

#### a. RS-232 connection setting value

Baud Rate: 115200

Parity: None

Data bits: 8

Stop bits: 1

Flow control: None

#### b. RS-232 command code

Function	Status	Action	cmd
Power	Write	Turn on	0x06 0x14 0x00 0x03 0x00 0x34 0x11 0x00 0x5C
		Turn off	0x06 0x14 0x00 0x03 0x00 0x34 0x11 0x01 0x5D
	Read	Power status( on/off/cool down)	0x07 0x14 0x00 0x05 0x00 0x34 0x00 0x00 0x11 0x00 0x5E
Reset		Excute	0x06 0x14 0x00 0x03 0x00 0x34 0x11 0x02 0x5E
Mirror	Write	Normal	0x06 0x14 0x00 0x04 0x00 0x34 0x12 0x00 0x00 0x5E
		H Inverse	0x06 0x14 0x00 0x04 0x00 0x34 0x12 0x00 0x01 0x5F
		V Inverse	0x06 0x14 0x00 0x04 0x00 0x34 0x12 0x00 0x03 0x61
		H&V Inverse	0x06 0x14 0x00 0x04 0x00 0x34 0x12 0x00 0x02 0x60
	Read	Mirror status	0x07 0x14 0x00 0x05 0x00 0x34 0x00 0x00 0x12 0x00 0x5F
Contrast (only For User Mode)	Write	Contrast decrease	0x06 0x14 0x00 0x04 0x00 0x34 0x12 0x02 0x00 0x60
		Contrast increase	0x06 0x14 0x00 0x04 0x00 0x34 0x12 0x02 0x01 0x61
	Read	Contrast ratio	0x07 0x14 0x00 0x05 0x00 0x34 0x00 0x00 0x12 0x02 0x61

Brightness (only For User Mode)	Write	Brightness decrease	0x06 0x14 0x00 0x04 0x00 0x34 0x12 0x03 0x00 0x61
		Brightness increase	0x06 0x14 0x00 0x04 0x00 0x34 0x12 0x03 0x01 0x62
	Read	Brightness	0x07 0x14 0x00 0x05 0x00 0x34 0x00 0x00 0x12 0x03 0x62
Aspect ratio	Write	Aspect ratio Auto	0x06 0x14 0x00 0x04 0x00 0x34 0x12 0x04 0x00 0x62
		Aspect ratio Native	0x06 0x14 0x00 0x04 0x00 0x34 0x12 0x04 0x01 0x63
		Aspect ratio 4:3	0x06 0x14 0x00 0x04 0x00 0x34 0x12 0x04 0x02 0x64
		Aspect ratio 16:9	0x06 0x14 0x00 0x04 0x00 0x34 0x12 0x04 0x03 0x65
	Read	Aspect ratio	0x07 0x14 0x00 0x05 0x00 0x34 0x00 0x00 0x12 0x04 0x63
Auto Adjust		Excute	0x06 0x14 0x00 0x03 0x00 0x34 0x12 0x05 0x62
Horizontal position	Write	Horizontal position shift right	0x06 0x14 0x00 0x04 0x00 0x34 0x12 0x06 0x01 0x65
		Horizontal position shift left	0x06 0x14 0x00 0x04 0x00 0x34 0x12 0x06 0x00 0x64
	Read	Horizontal position	0x07 0x14 0x00 0x05 0x00 0x34 0x00 0x00 0x12 0x06 0x65
Vertical position	Write	Vertical position shift up	0x06 0x14 0x00 0x04 0x00 0x34 0x12 0x07 0x00 0x65
		Vertical position shift down	0x06 0x14 0x00 0x04 0x00 0x34 0x12 0x07 0x01 0x66
	Read	read Vertical position	0x07 0x14 0x00 0x05 0x00 0x34 0x00 0x00 0x12 0x07 0x66
Color temperature (only For User Mode)	Write	color temperatureT1	0x06 0x14 0x00 0x04 0x00 0x34 0x12 0x08 0x00 0x66
		color temperatureT2	0x06 0x14 0x00 0x04 0x00 0x34 0x12 0x08 0x01 0x67
		color temperatureT3	0x06 0x14 0x00 0x04 0x00 0x34 0x12 0x08 0x02 0x68
		color temperatureT4	0x06 0x14 0x00 0x04 0x00 0x34 0x12 0x08 0x03 0x69
	Read	color temperature status	0x07 0x14 0x00 0x05 0x00 0x34 0x00 0x00 0x12 0x08 0x67
Blank	Write	Blank on/off	0x06 0x14 0x00 0x03 0x00 0x34 0x12 0x09 0x66
	Read	Blank status	0x07 0x14 0x00 0x05 0x00 0x34 0x00 0x00 0x12 0x09 0x68
Keystone-Vertical	Write	Decrease	0x06 0x14 0x00 0x04 0x00 0x34 0x12 0x0A 0x00 0x68
		Increase	0x06 0x14 0x00 0x04 0x00 0x34 0x12 0x0A 0x01 0x69
	Read	Keystone status	0x07 0x14 0x00 0x05 0x00 0x34 0x00 0x00 0x12 0x0A 0x69
Preset mode	Write	Preset mode 0	0x06 0x14 0x00 0x04 0x00 0x34 0x12 0x0B 0x00 0x69
		Preset mode 1	0x06 0x14 0x00 0x04 0x00 0x34 0x12 0x0B 0x01 0x6A
		Preset mode 2	0x06 0x14 0x00 0x04 0x00 0x34 0x12 0x0B 0x02 0x6B
		Preset mode 3	0x06 0x14 0x00 0x04 0x00 0x34 0x12 0x0B 0x03 0x6C
		Preset mode 4 (PC User I)	0x06 0x14 0x00 0x04 0x00 0x34 0x12 0x0B 0x04 0x6D
		Preset mode 5 (PC User II )	0x06 0x14 0x00 0x04 0x00 0x34 0x12 0x0B 0x05 0x6E
	Read	Preset mode status	0x07 0x14 0x00 0x05 0x00 0x34 0x00 0x00 0x12 0x0B 0x6A
Freeze	Write	Freeze on/off	0x06 0x14 0x00 0x03 0x00 0x34 0x13 0x00 0x5E
	Read	Freeze status	0x07 0x14 0x00 0x05 0x00 0x34 0x00 0x00 0x13 0x00 0x60
Source input	Write	Input source VGA	0x06 0x14 0x00 0x04 0x00 0x34 0x13 0x01 0x00 0x60
		Input source YPbPr	0x06 0x14 0x00 0x04 0x00 0x34 0x13 0x01 0x04 0x63
		Input source Composite	0x06 0x14 0x00 0x04 0x00 0x34 0x13 0x01 0x05 0x65
		Input source SVIDEO	0x06 0x14 0x00 0x04 0x00 0x34 0x13 0x01 0x06 0x66
	Read	Source	0x07 0x14 0x00 0x05 0x00 0x34 0x00 0x00 0x13 0x01 0x61
Source scan	Write	Source scan on	0x06 0x14 0x00 0x04 0x00 0x34 0x13 0x02 0x01 0x62
		Source scan off	0x06 0x14 0x00 0x04 0x00 0x34 0x13 0x02 0x00 0x61
	Read	Source scan status	0x07 0x14 0x00 0x05 0x00 0x34 0x00 0x00 0x13 0x02 0x62
Mute	Write	Mute on	0x06 0x14 0x00 0x04 0x00 0x34 0x14 0x00 0x01 0x61
		Mute off	0x06 0x14 0x00 0x04 0x00 0x34 0x14 0x00 0x00 0x60
	Read	Mute status	0x07 0x14 0x00 0x05 0x00 0x34 0x00 0x00 0x14 0x00 0x61

Volume	Write	Increase Volume	0x06 0x14 0x00 0x03 0x00 0x34 0x14 0x01 0x60
		Decrease Volume	0x06 0x14 0x00 0x03 0x00 0x34 0x14 0x02 0x61
	Read	Volume	0x07 0x14 0x00 0x05 0x00 0x34 0x00 0x00 0x14 0x03 0x64
Language	Write	English	0x06 0x14 0x00 0x04 0x00 0x34 0x15 0x00 0x00 0x61
		Français	0x06 0x14 0x00 0x04 0x00 0x34 0x15 0x00 0x01 0x62
		Deutsch	0x06 0x14 0x00 0x04 0x00 0x34 0x15 0x00 0x02 0x63
		Italiano	0x06 0x14 0x00 0x04 0x00 0x34 0x15 0x00 0x03 0x64
		Español	0x06 0x14 0x00 0x04 0x00 0x34 0x15 0x00 0x04 0x65
		РУССКИЙ	0x06 0x14 0x00 0x04 0x00 0x34 0x15 0x00 0x05 0x66
		繁體中文	0x06 0x14 0x00 0x04 0x00 0x34 0x15 0x00 0x06 0x67
		简体中文	0x06 0x14 0x00 0x04 0x00 0x34 0x15 0x00 0x07 0x68
		日本語	0x06 0x14 0x00 0x04 0x00 0x34 0x15 0x00 0x08 0x69
		한국어	0x06 0x14 0x00 0x04 0x00 0x34 0x15 0x00 0x09 0x6A
		Swedish	0x06 0x14 0x00 0x04 0x00 0x34 0x15 0x00 0x0a 0x6B
		Dutch	0x06 0x14 0x00 0x04 0x00 0x34 0x15 0x00 0x0b 0x6C
		Turkish	0x06 0x14 0x00 0x04 0x00 0x34 0x15 0x00 0x0c 0x6D
		Czech	0x06 0x14 0x00 0x04 0x00 0x34 0x15 0x00 0x0d 0x6E
		Portugese	0x06 0x14 0x00 0x04 0x00 0x34 0x15 0x00 0x0e 0x6F
		Thai	0x06 0x14 0x00 0x04 0x00 0x34 0x15 0x00 0x0f 0x70
	Polish	0x06 0x14 0x00 0x04 0x00 0x34 0x15 0x00 0x10 0x71	
	Read	Language	0x07 0x14 0x00 0x05 0x00 0x34 0x00 0x00 0x15 0x00 0x62
Lamp Time	Write	Reset Lamp usage hour	0x06 0x14 0x00 0x03 0x00 0x34 0x15 0x01 0x61
	Read	Lamp usage hour	0x07 0x14 0x00 0x05 0x00 0x34 0x00 0x00 0x15 0x01 0x63
error status	Read		0x07 0x14 0x00 0x05 0x00 0x34 0x00 0x00 0x15 0x02 0x64

### Error code table

To send Hex code "error status" read "0x07 0x14 0x00 0x05 0x00 0x34 0x00 0x00 0x15 0x02 0x64". User can get 20 byte data which mapping to below error status and the number means how many time the error appeared.

Byte	Error Name	Description
0	LampFailCount	Lamp turn on fail
1	Fan1ErrorCount	Fan1 fail (lamp fan)
2	Fan2ErrorCount	Fan2 fail (power fan)
3	Fan3ErrorCount	Fan3 fail (blower fan)
4	Fan4ErrorCount	Fan4 fail (The model without 4 fans without this error count)
5	Diode1OpenErrorCount	Thermal sensor 1 lose connection
6	Diode2OpenErrorCount	Thermal sensor 2 lose connection
7	Diode3OpenErrorCount	Thermal sensor 3 lose connection (The model without thermal sensor 3 is no function for this address)
8	Diode1ShortErrorCount	Thermal sensor 1 short (inlet sensor which located at main board)
9	Diode2ShortErrorCount	Thermal sensor 2 short (power board temperature sensor)
10	Diode3ShortErrorCount	Thermal sensor 3 short (The model without thermal sensor 3 is no function for this address)
11	Temperature1ErrorCount	Thermal sensor 1 detect temperature over system limitation (inlet sensor which located at main board)
12	Temperature2ErrorCount	Thermal sensor 2 detect temperature over system limitation (power board temperature sensor)
13	Temperature3ErrorCount	Thermal sensor 3 detect temperature over system limitation (No used)
14	FanIC1ErrorCount	Fan IC 1 fail (G743 or G794)
15	FanIC2ErrorCount	No used
16	WatchdogCount	The DDP2230 internal F/W watchdog function executed
17	AbnormalPowerdown	The user turn off unit without finish cooling process
18	CWErrorCount,	Color wheel do not spin
19	FirstBurnInErrorMinutes	The timeframe from burn-in to 1 <sup>st</sup> time shutdown in minute.

#### 4. Method to enter factory menu:

a) Press **Menu** on keypad than the main menu popup

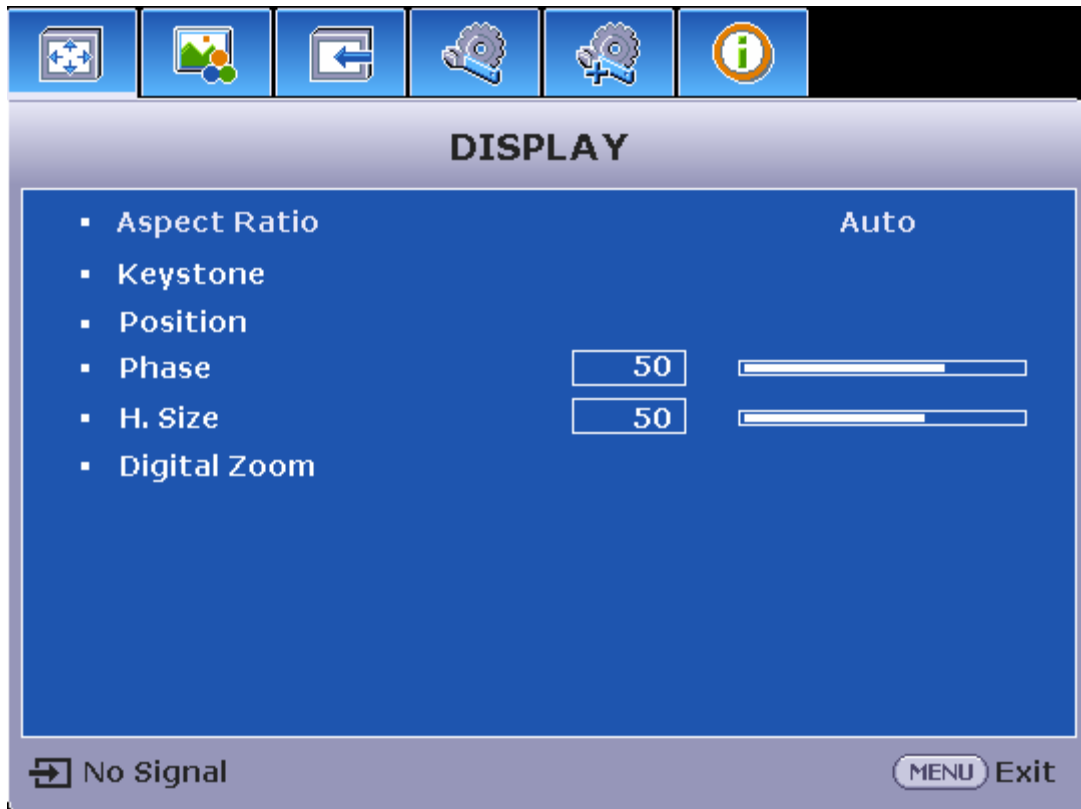

b) When showing main menu, press **Source + Mode** at the same time

c) Factory menu popup at the top-left of display



## 5. Adjustment Procedure

### Visual Inspection & Cleaning

#### Visual Inspection Criteria

##### 1.0 Inspection zone definition and inspection distance

A-side: Up case - Up case surfaces except right / left / behind side's surface.

Front cover - Front cover surface

B-side: Side - right/left sides surfaces

Back cover - Back cover surfaces

C-side: Low case - bottom surfaces

- For spot inspection distance is 45 cm on A/B/C-side. And inspection time is 10 sec.
- For scratch inspection distance is 45 cm on A/B/C-side. And inspection time is 10 sec.

##### 1.1 Appearance Inspection Criteria

###### 1.1.1 Environment Condition

###### 1.1.1.1 Lighting intensity

All appearance quality shall be inspected with the lighting condition as 500~800Lux (natural lighting or white fluorescent light).

###### 1.1.1.2 Inspection angle and distance to object or target

All part inspection must be done under direct overhead lighting. Viewing angle and distance are dependent on surface classification. In all cases, parts must be held in such that the light reflection does not disturb the inspector's eye.

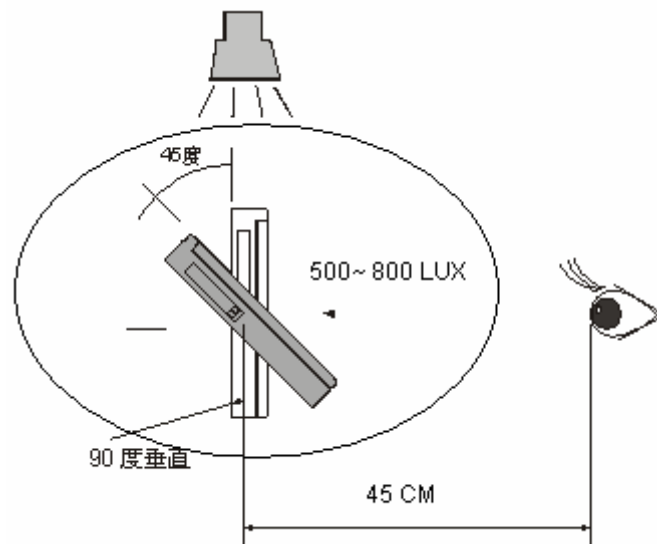

Figure 1

Table 1

Classification	Area A	Area B	Area C
Lighting positioning	Above of inspected part		
Inspection position relative to part	90°	90°	90°
Inspection distance	40~50 cm	40~50 cm	40~50 cm

1.1.1.3 Inspection interval (time)

Inspection interval is a function of surface area.

Time for visual inspection: 10sec.

Table 2

Parts Size	“A” surface	“B” surface	“C” surface
Time	10 sec	10 sec	10 sec

TABLE 3 General Product of plastic outlook of dot, blemish, and others spec inspection standard

	Spec (Area cm <sup>2</sup> )	A surface (Number of defect)				B surface (Number of defect)				C surface (Number of defect)			
		20*20	50*50	70*70	100*100	20*20	50*50	70*70	100*100	20*20	50*50	70*70	100*100
Particle Blemish   Color spot	P < 0.2 mm <sup>2</sup> Distance ≥ 2cm	Ignore	Ignore	Ignore	Ignore	Ignore	Ignore	Ignore	Ignore	Ignore	Ignore	Ignore	Ignore
	0.2 ≤ P < 0.3 mm <sup>2</sup> Distance ≥ 4cm	2	3	4	5	2	3	4	5	4	4	5	6
	0.3 ≤ P < 0.4mm <sup>2</sup> Distance ≥ 4cm	0	0	0	0	2	3	4	5	3	4	5	6
Particle   Spot with same color	P < 0.1 mm <sup>2</sup> Distance ≥ 2cm	Ignore	Ignore	Ignore	Ignore	Ignore	Ignore	Ignore	Ignore	Ignore	Ignore	Ignore	Ignore
	0.1 ≤ P < 0.2mm <sup>2</sup> Distance ≥ 4cm	4	4	5	6	5	5	6	7	6	6	7	8
	0.2 ≤ P < 0.3mm <sup>2</sup> Distance ≥ 4cm	3	4	4	5	4	5	5	6	6	7	7	8
	0.3 ≤ P < 0.5mm <sup>2</sup> Distance ≥ 5cm	2	2	3	4	3	3	4	5	4	4	5	6
	Total	4	4	5	6	5	5	6	7	6	6	7	8

**Note:**

1. Use the 20\*20 criteria to the area less than 20\*20; 50\*50 inspection criteria to the area 20\*20 ≤ A < 50\*50; etc.

(Particle/Blemish/Color Spot)

1.1 Definition of surface A, B, C refer to 6.2

1.2 Blemish around the ViewSonic Bird logo, name plate and silk screen must be equal or smaller than 0.05 mm<sup>2</sup>

1.3 Bubble on the surface is to be reject.

TABLE 2 : General Product of plastic outlook inspection standard

NO	Appearance	Spec
1	Shrinkage	A region: No Shrink. With gloves, no feeling of sink when touching the surface B/C region: not obvious
2	Run, Texture, Gloss	No obvious non-uniformity
3	Welding Line/Knit Line	Follow limit sample level
4	Ejector Mark	Reject
5	Label/screws shortage	Reject
6	Material shortage	Not allow, Reject
7	Chromatic aberration	Follow engineering specification
8	Printing	Printing must not have incomplete printing, break off, overlap, uneven thickness, excessive ink, printing misalignment (1.5mm), printing slanting & crooked (<0.5mm) Printing color must be comparable to color chip and sample. Follow engineering specification
9	Logo of panel sticker	Printing must not have incomplete printing, break off, overlap, uneven thickness, excessive ink, printing misalignment (1mm), printing slanting & crooked (<0.5mm) Printing color must be comparable to color chip and sample.
10	Scratch/Nicks	Side A: (W < 0.1mm , L < 5mm): Only 2 this kind of scratch is accepted W < 0.1mm , L < 5-10mm :Only 1 this kind of scratch is accepted Side B: W < 0.2mm , L < 5mm : Only less than 2 this kind of scratch is accepted W < 0.2mm , L < 5-10mm : Only 1 this kind of scratch is accepted Side C: W < 0.3mm , L < 5mm : Only 3 this kind of scratch is accepted W < 0.3mm , L < 5-10mm : Only 2 this kind of scratch is accepted W < 0.3mm , L < 10-15mm: Only 0 this kind of scratch is accepted Note: 1. Severe scratch which disclose the Natural 2. When light scratching on it, there's no feeling of obstruction. Also, there should not be obvious difference in gloss nearby it. 3. Each scratch should be 5cm more far away from each other 4. Front case must be no any scratch

## PART II Operational Inspection Criteria

### TEST CONDITIONS

Unless other prescription, the test conditions are as followings:

Nominal voltage: refer to operation manual

Environmental illumination:

Variable from 500 to 800 Lux (For appearance inspection)

Variable from 0 to 7 Lux (For functional inspection)

Temperature:  $25\pm 5^{\circ}\text{C}$

Visual inspection shall be done with the distance from eyes to the sample 45 cm.

Display mode: refer to operation manual

### TEST EQUIPMENTS

Dark room

PC

Pattern Generator: Chroma 2327 or equivalent

Minolta color analyzer CL200 or equivalent device with accredited traceability

DVD player

Power supply (100~240 VAC) with consumption meter

Measuring tape

### TEST PATTERN

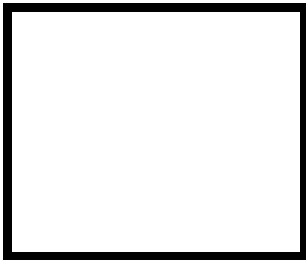
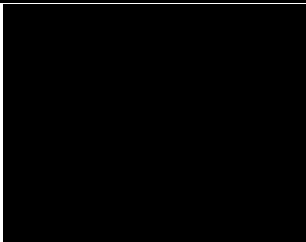
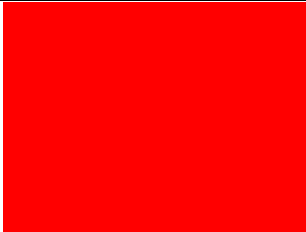
PATTERN	PATTERN	TEST ITEM	Acceptance Criteria
Full white		ANSI Brightness Bright Uniformity FOFO Contrast Ratio	(1) ANSI Brightness:(Normal Mode) 1600lm (2) Uniformity: ANSI: 55% (Minimum) (3) Contrast Ratio : 150:1 (Minimum, by ANSI Standard Checkerboard Method), 1200:1(by All White, All Black Method) (4) White Point, Color :x = $0.312\pm 0.04$ , y = $0.354\pm 0.04$
Full Dark		FOFO Contrast Ratio	Contrast Ratio : 1200:1(by All White, All Black Method)
Full Red		Impurity CIE coordinate	Chromaticity : Red: x = $0.640\pm 0.04$ , y = $0.345\pm 0.04$

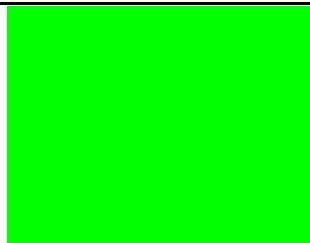
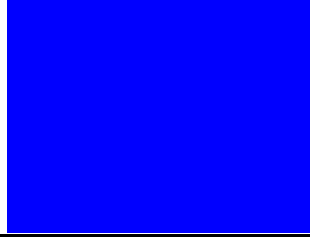
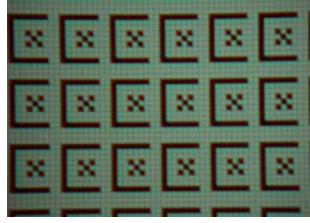
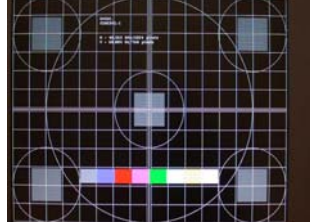
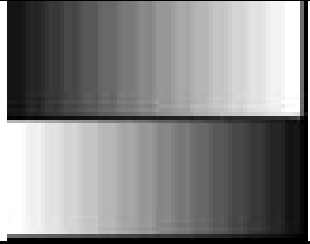
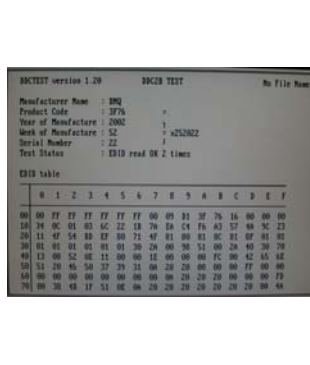
Full Green		Impurity · CIE coordinate	Chromaticity : Green: $x = 0.355 \pm 0.04$ , $y = 0.548 \pm 0.04$
Full Blue		Impurity · CIE coordinate	Chromaticity : Blue: $x = 0.141 \pm 0.04$ , $y = 0.087 \pm 0.04$
Chromo 800x600		Focus Range	(1)Background lines should be distinguishable. (2)"☒":Letter shape and lines should be distinguishable.
General-1 pattern		Performance/ Timing check/ function check	(1)Phase should be stable(no flick) (2)Whole frame should appear.
16 Gray and Color bar		Gray and Color bar Check	No lack or mix color
DDC check		Check the DDC information, Including S/N, model, manufacturer name, product code.	S/N(08-09): with numbers Model(108-125) with numbers(ref Appendix DDC table) manufacturer name(08-09):5A63 product ID code (10-11): 20C5

# Software/Firmware Upgrade Process

## How to Download Firmware

### Hardware required

1. Standard RS-232 Download cable
2. Personal computer or laptop computer

### Software required

1. DDP2230 Composer lite
2. New version FW

## DDP2230 Composer lite install procedure

### Installation Location

The default installation directory is:

**C:\Program Files\DLP Composer Lite 7.0**

If you want to install to a different directory (perhaps alongside a prior release of DLP Composer™ Lite), click the "Browse" button on the "Select Features" page..

### USB Support - Installation (All Platforms)

This release includes support for a USB communications interface to DDP2230-based projectors. The setup program includes the files needed to install USB support (for Win98/WinMe/Win2K/WinXP only -- Win95 and WinNT are not supported).

After DLP Composer™ Lite is installed, to install the USB support, choose the "Install DDP2230 USB Driver" icon under "DLP Composer™ Lite" in your **Start** menu.



### USB Support - Win98/Me/XP Only

Installation on Windows 98/Me/XP may prompt "Please insert the disk labeled 'DLP Composer Installation Directory', and then click OK". This message may be safely ignored by **clicking the OK button**.

Another prompt will then appear: "The file 'windrvr6.sys' on DLP Composer Installation Directory cannot be found". Again, **click OK** and the installation proceeds without further problems.

## USB Support - Using a projector for the first time

After installation is complete, and you plug a DDP2230-based projector into USB for the first time, Windows will run the "New Hardware Wizard". When the wizard prompts to find the necessary drivers, accept the recommended choice (let the system find the driver for you) and click "Next" to complete the installation.

**Note: The Windows 98/Me/XP "New Hardware Wizard" may not automatically find the driver. You should use the "Advanced" option, and enter the directory where the DLP Composer™ Lite Tool Suite was installed (normally "C:\Program Files\DLP Composer Lite"). The wizard will find the file "DDP2230.inf" and complete the installation.**

## USB Support - Choosing the USB interface

To select the USB communications interface, choose "Preferences" from the "Edit" menu, click the "Communications" page and choose "USB (DDP2000/DDP3020 Only)". You can now use DLP Composer™ Lite to communicate with a DDP2230-based projector via USB using the Flash Loader tool.

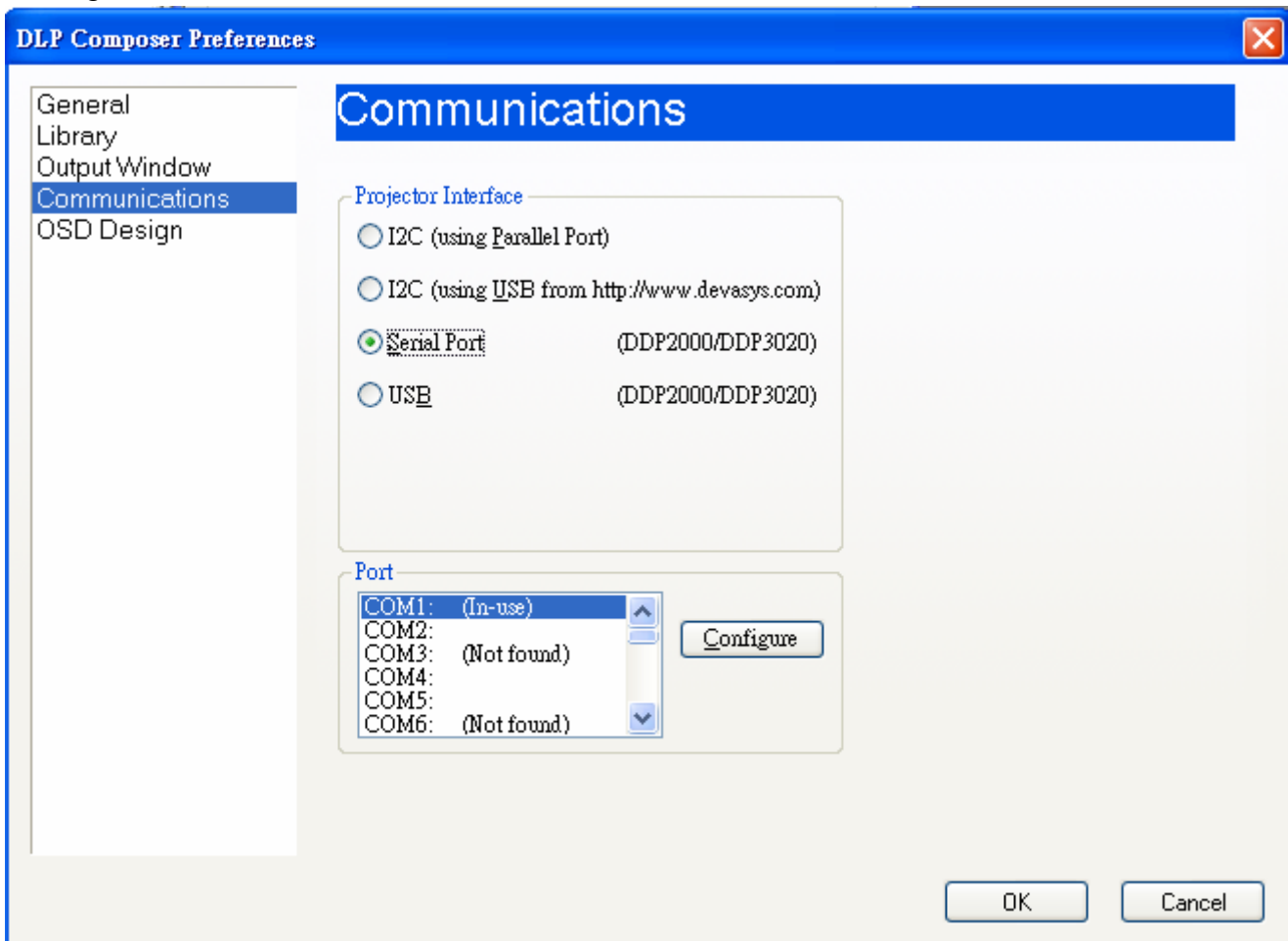

## Download procedure

1. Click on Flash Loader and browse the image file (new version firmware)
2. Make sure to check “Skip Boot loader area (load all but the first 32KB)”
3. Plug power cord into projector
4. Plug in RS-232 cable between computer and projector side
5. Press start download to begin update new firmware

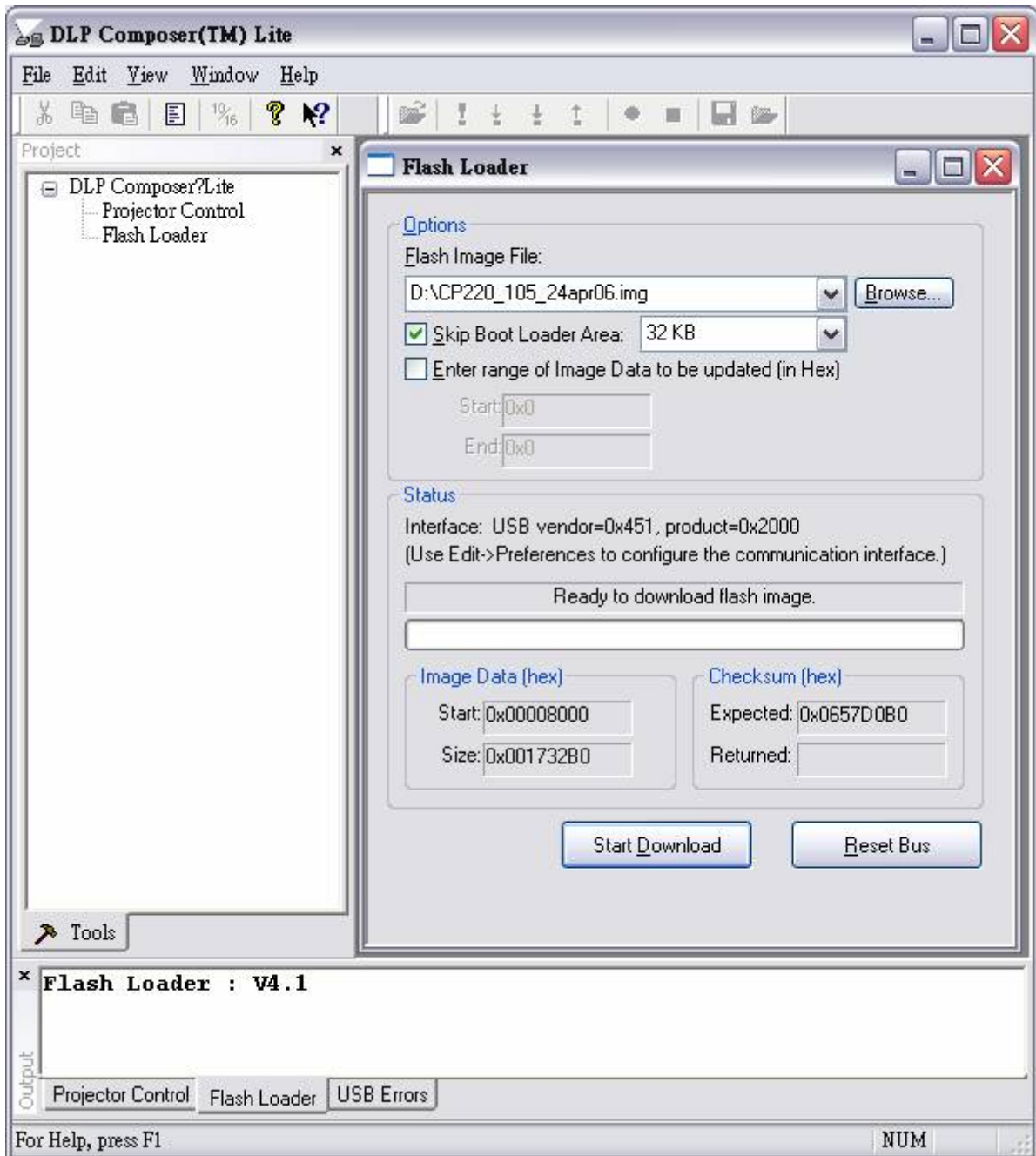

6. Wait till composer lite notice upgrade completed
7. Download is completed. The factory settings should be restored.



# 1. EE Assembly and Alignment Concern:

## 1. Color Wheel Delay Alignment

### Equipment:

- Battery Biased Silicon PIN Detector
- Oscilloscope
- Probe

OSD Default value:

Item	Value	Item	Value
DLP Brightness	32	CW Delay	Adjustable
DLP Contrast	32		
White Peak	10		

The default values let optical engine to get maximum contrast and brightness.

### Procedure:

Probe impedance matches 50 ohm

Open Factory OSD, and select color wheel delay item

Leave the image pure red (DMD red curtain)

Put the detector on the screen that red image was projected.

Watch the oscilloscope and notice the square waveform

Use the “→” and “←” key to increment or decrement the color wheel delay value

No matter the waveform is square or not, let the waveform was lagged first

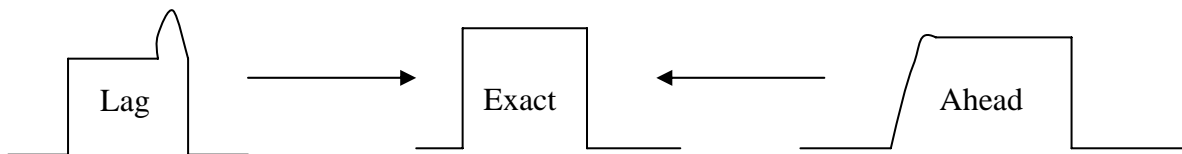

Then increment or decrement the value to let the waveform to be square

Do not adjust too much, let the signal get ahead, if it happens, go back to step 7 and do it again.

Change the input to pure blue and repeat the above procedures again.

Change the input to pure green and repeat the above procedures again.

## 2. Main board check procedure

### Equipment:

- Pattern generator

### Procedure:

1. Connect power, D-sub into projector.
2. Light on projector.
3. Testing below patterns and resolution is [854\\*480@60Hz](#) (480P)
  - (1) General-1 pattern. (Pattern 1)
  - (2) 32 grays pattern. (Pattern 48)
  - (3) White pattern. (Pattern 41)

(4) SMPTE pattern. (Pattern 5)

4. The main board would be note fail if above four image-quality is not good.
5. Test the connection between main board and IR board.
6. The main board would be note fail if there are some broken occur in wire or main board.

### 3. DMD Panel Alignment

#### Equipment:

- Pattern Generator

#### Procedure:

1. Connect power, Video signal into projector.
2. Light on projector
3. Change pattern generator to full white pattern.
4. Watch the image if any pixel lost
5. Change pattern to full black.
6. Watch the image if any pixel lost
7. Change pattern from full black to full white.
8. Watch the image if any pixel can not return
9. Change pattern from full black to full white.
10. Watch the image if any pixel can not return
11. If above 8 step has some pixel lost or can not return, it's DMD chip has pixel defect
12. Change to the Slid Line pattern
13. Watch the image if any pixel lost
14. If above step has some pixel lost, it's conductive socket has defect or assembly loosed.

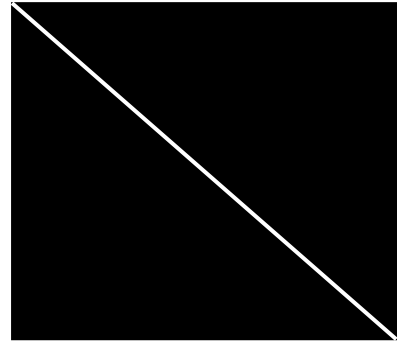

### 4. PC Alignment Procedure

#### Equipment:

- Pattern generator (Chroma-2250)

OSD Default value:

Item	Value
Cal R Offset	127
Cal G Offset	127
Cal B Offset	127
Cal R Gain	127
Cal G Gain	127
Cal B Gain	127
YPbPr R Offset	127
YPbPr B Offset	127

## Procedure:

### Gray Level:

1. Connect power, D-sub, into projector.
2. Change Timing and pattern of pattern generator:
3. Timing: [800\\*600@60](#)
4. Pattern: As Figure1 {A near white color (240,240,240) and a near black color(16,16,16), the area of white is 101/200, black is 99/200}
5. Light on projector
6. Set user OSD values to default.
7. Enter factory mode.
8. Set Factory values to default.
9. Press "Calibration RGB" to let the black level to just distinguish, and the light output of white level to just max.
10. Check the 32 levels of gray. All steps must appear.

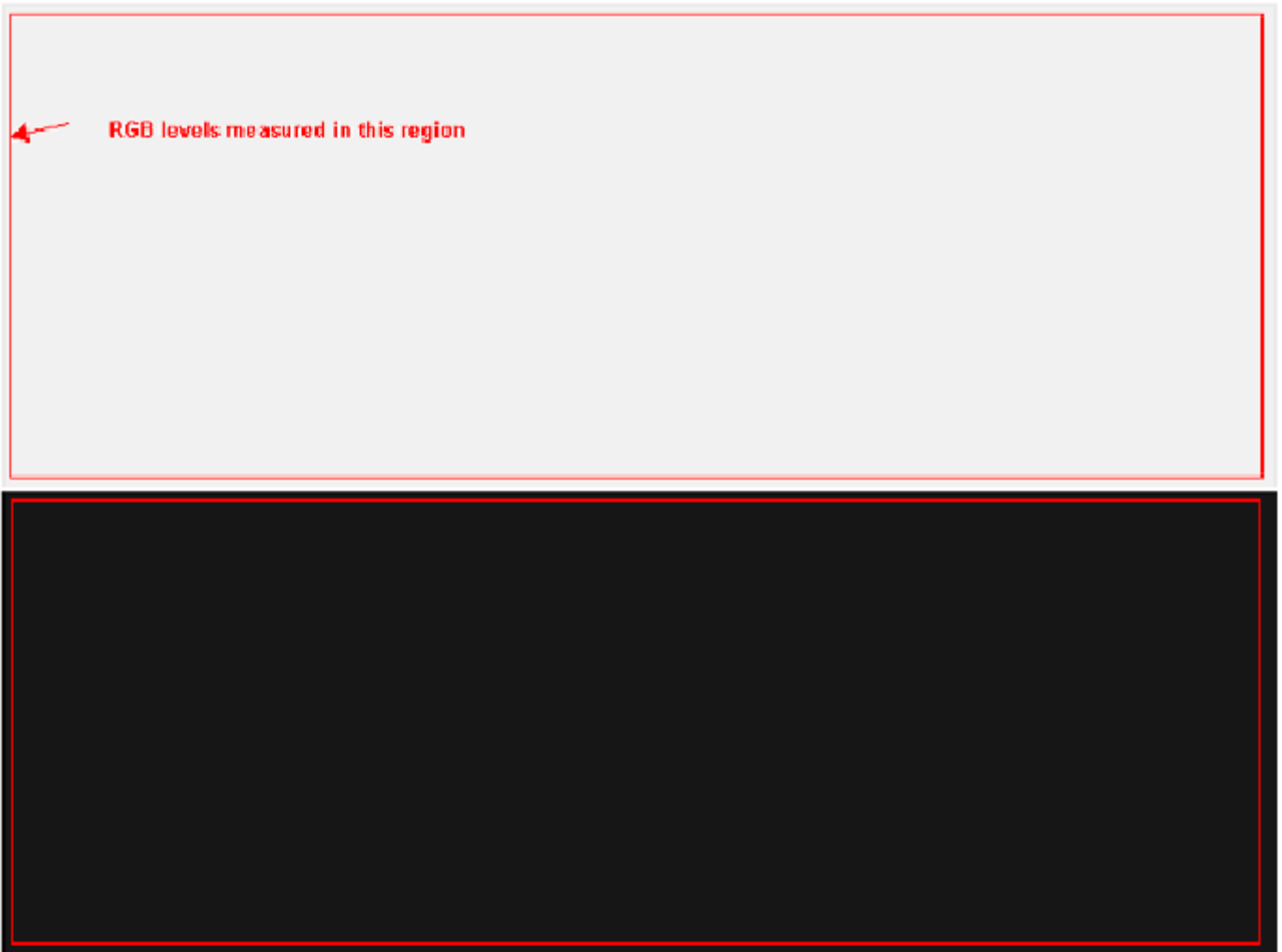

Figure1

## 5. YUV Alignment Procedure

### Equipment:

- Pattern generator (VG-828)

OSD Default value:

Item	Value
Cal R Offset	127
Cal G Offset	127
Cal B Offset	127
Cal R Gain	127
Cal G Gain	127
Cal B Gain	127
YPbPr R Offset	127
YPbPr B Offset	127

### Procedure:

1. Connect power core, YPbPr cable into projector.
2. Change timing and pattern of pattern generator:  
Timing: 480i  
Pattern: As Figure2
3. Light on projector
4. Adjust user OSD values to default.
5. Enter factory mode.
6. Adjust Factory values to default.
7. Press "Calibration YPbPr" to calibrate the mid level offset.



Figure2

## 2. Optical Engine Assembly and Alignment Concerns

### 1. Assembly Lamp module:

#### 1.1 Washer, Screw, Fin and Mesh Assembly

- I. Assemble Washer and Screw to the HLD Lamp(Fig. 1-1)
- II. Assemble “MESH” with Lamp holder .Mesh hooks HLD Lamp first (Fig. 1-2) and press it assemble to the right position (Fig. 1-3).
- III. Assemble “FIN” with Lamp holder and fasten screw (Fig. 1-4).

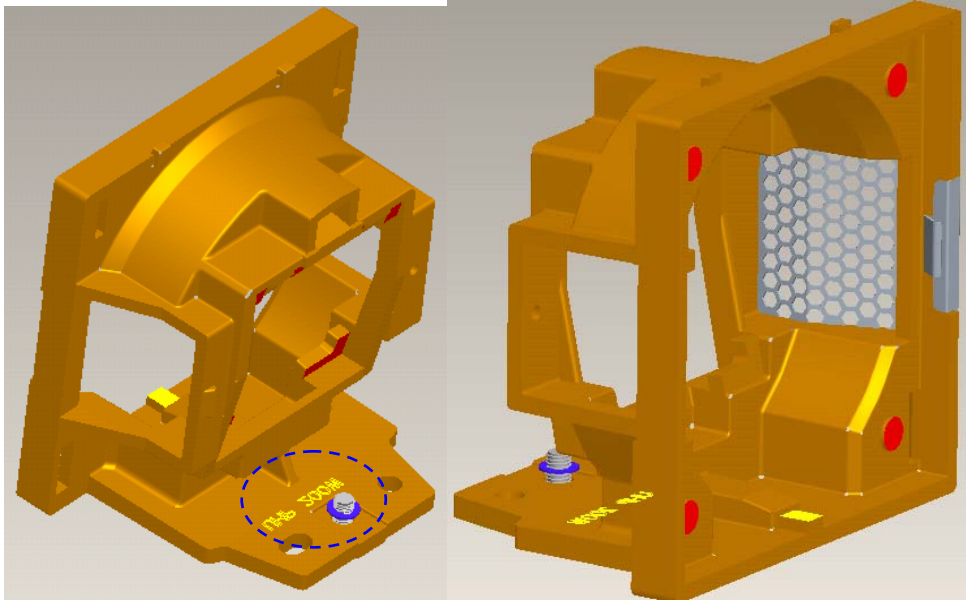

Fig. 1-1

Fig. 1-2

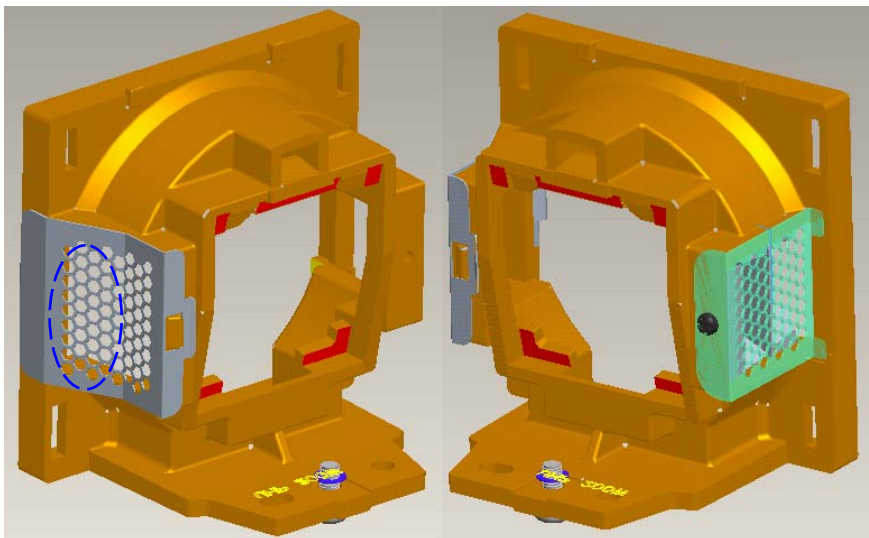

Fig. 1-3

Fig. 1-4

## 1.2 Front Glass Assembly.

- i. Front Glass UV coated surface (marked) must face to Lamp. (Fig. 1-6)
- ii. F/G must be placed on datum surfaces well. (Fig. 1-7)
- iii. To make sure F/G Clip hooked well with HLD lamp. (Fig. 1-8)

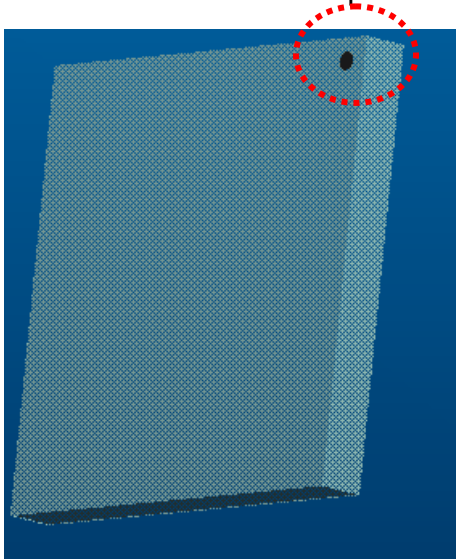

Fig. 1-6

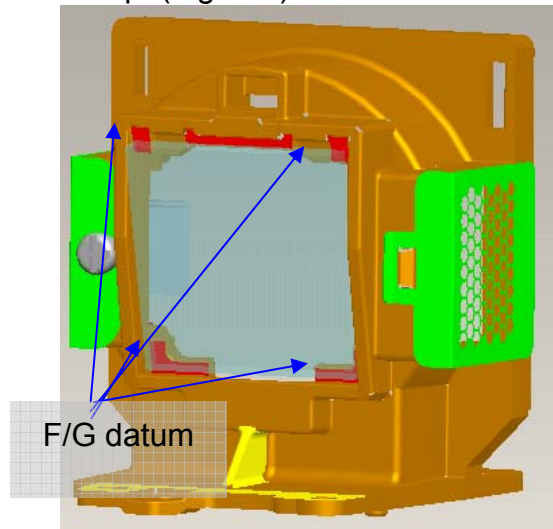

Fig. 1-7

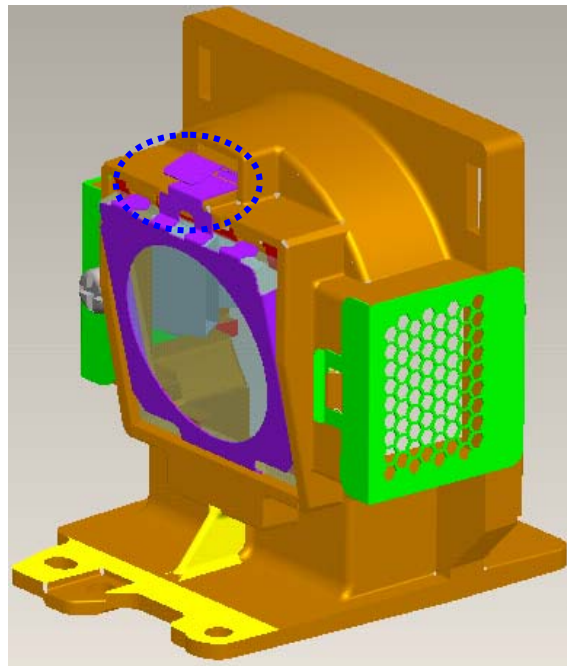

Fig. 1-8

## 1.3 Lamp wire and Lamp Assembly.



Fig. 1-9

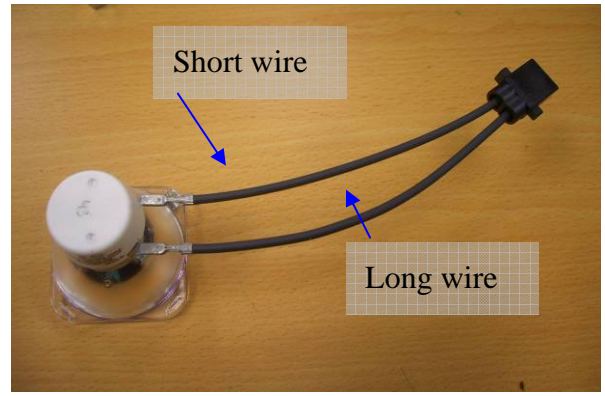

Fig. 1-10

- i. Insert Lamp into HLD Lamp and push Lamp forward to touch DTM Lamp of HLD Lamp (Fig. 1-11)
- ii. To make sure that three datum contact with the lamp well(Fig. 1-12)
- iii. After assemble Lamp to HLD Lamp, Hook “Clip down Lamp” first then Hook “Clip UP Lamp” on the HLD Lamp to fix Lamp last. (Fig. 1-13 、 1-14)
- iv. Check assembly again and make sure the three datum contact with the lamp.
- v. Assemble Plate Lamp to the HLD Lamp and fasten the screw(Fig. 1-15)

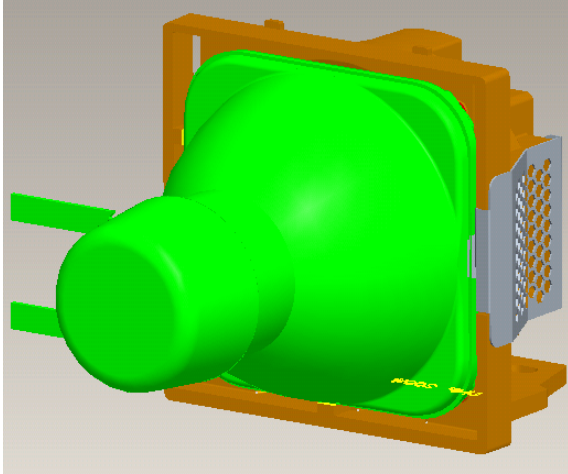

Fig. 1-11

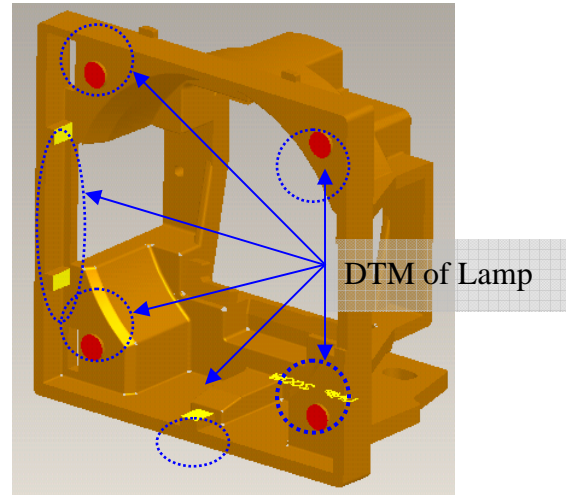

Fig. 1-12

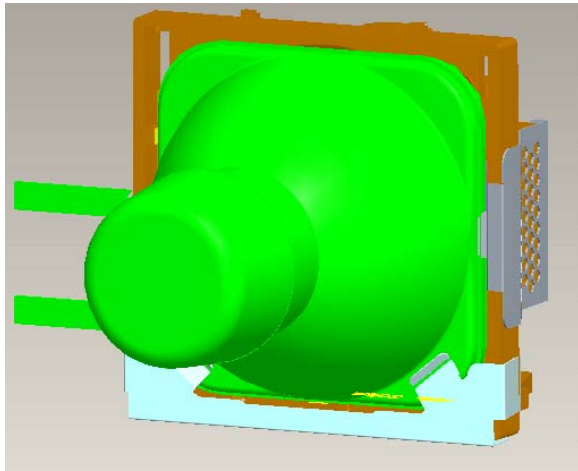

Fig. 1-13

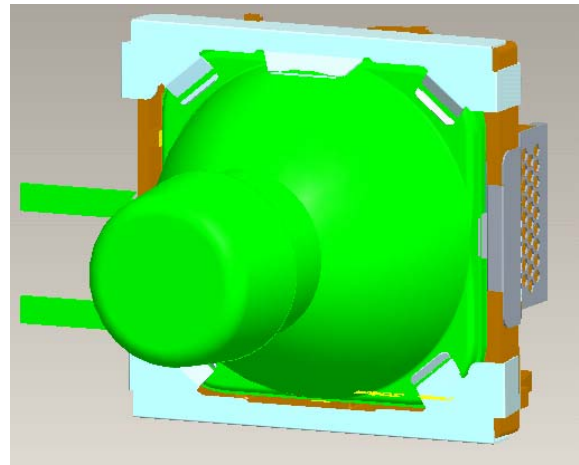

Fig. 1-14



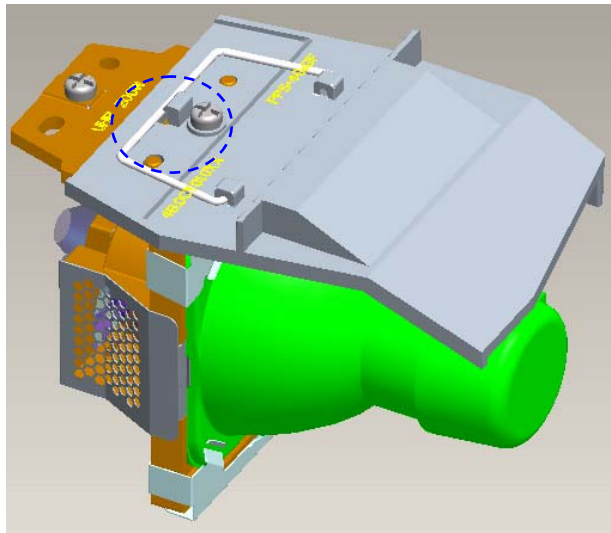

Fig. 1-15

## 2. BKT LINK Lamp and CW Shield Assembly

2.1. Insert CW Shield and hook BKT LINK Lamp

2.2. Fasten screw (Fig. 2-1.2-2)

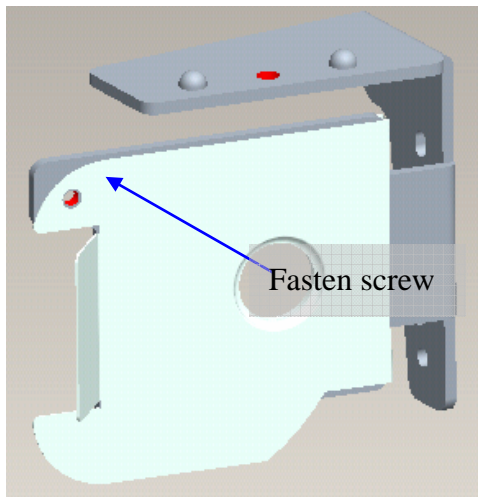

Fig. 2-1

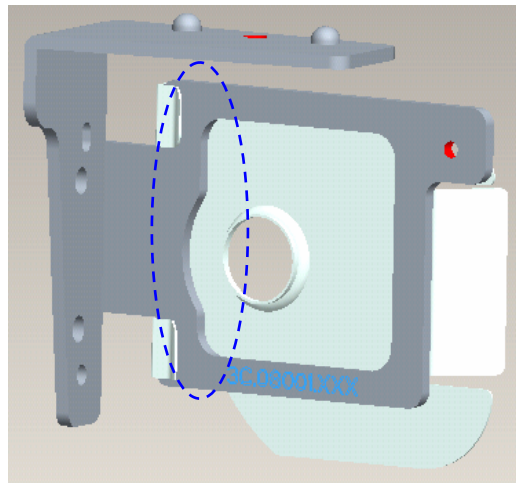

Fig. 2-2

## 3. Assembly CW Module

3.1 CW Module Assembly Sequence as blow (Fig. 3-1):

- (1) BKT CW (2) Damper CW (3) CW (4) Fixed screw (5) CVR CW  
(6) M2 Screw (7) Sensor Board (8) M2 Screw

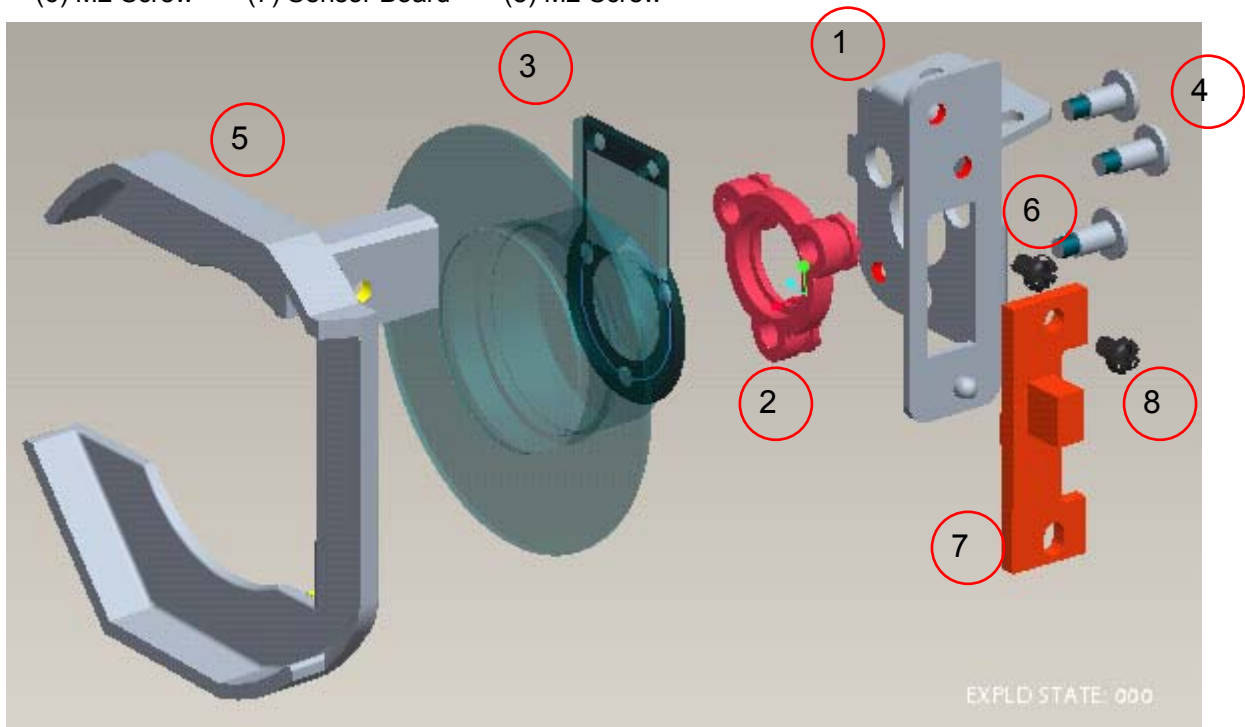

Fig. 3-1

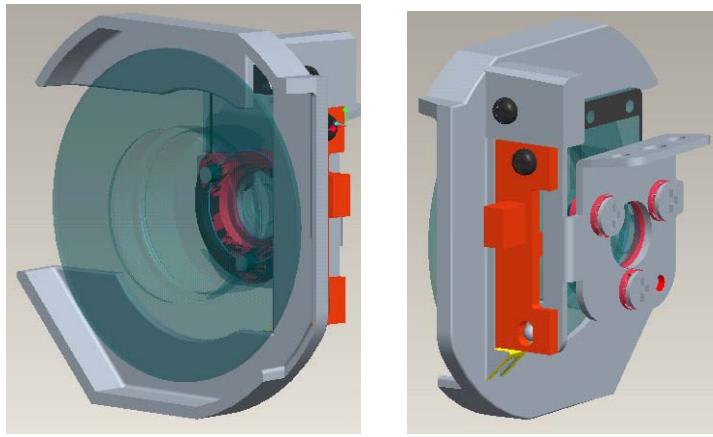

Fig. 3-2

#### 4. Assembly Baffle Stop AL

4.1. Assemble Baffle Stop AL on HSG DMD and fasten screw (Fig. 4-1)

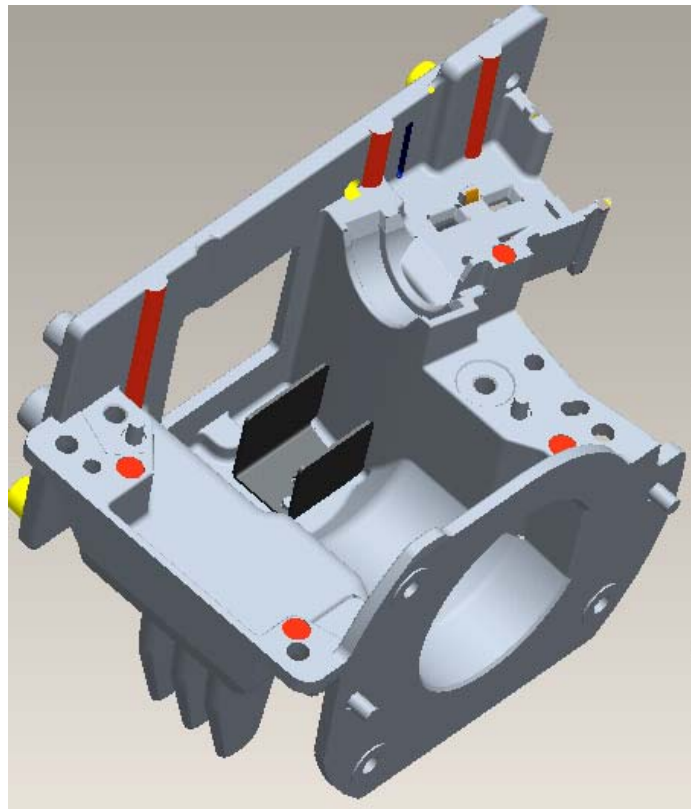

Fig. 4-1

#### 5. Assembly LP Module

5.1 LP must datum well with “BKT\_LP” show as Figure 5-1

5.2 Referring to Figure 5-2, there must be visible clearance between “BKT\_LP” and “LP opening” after assembly ◦

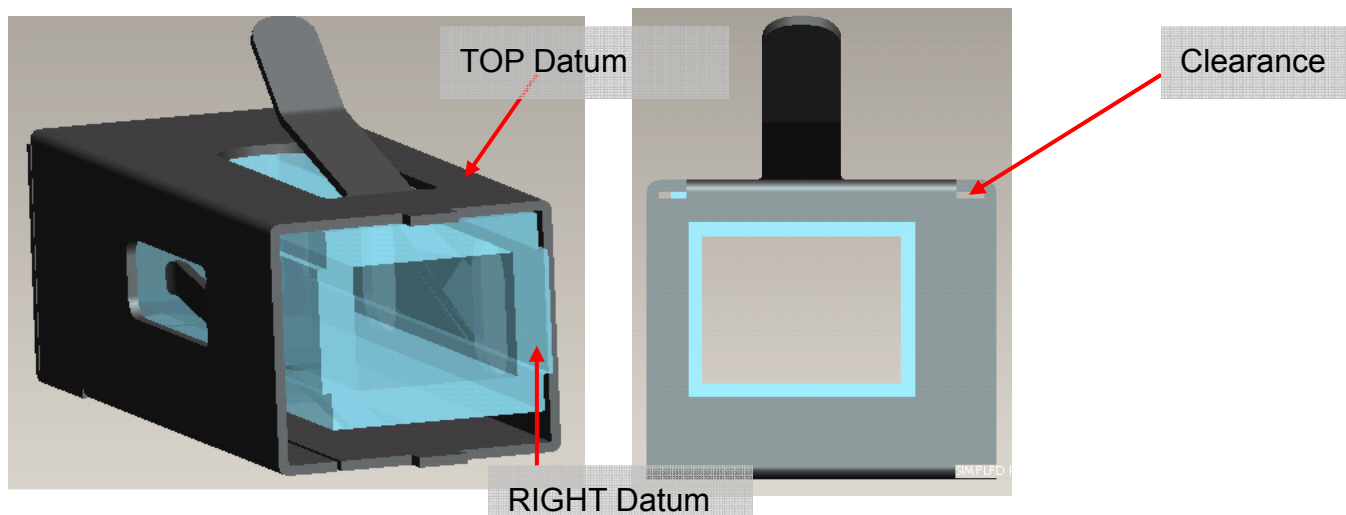

Fig. 5-1

Fig. 5-2

5.3 Glue “LP” and “BKT\_LP” with “UV5503 Glue” at two opening of “BKT\_LP” show in Figure 5-3.

5.4 UV-5503 Glue curing process and concerns:

- vi. The UV-glue must fill up the whole opening area (shown in Figure 5-3) to contact well

- with LP surfaces and BKT\_LP.
- vii. Exposed to visible light at 350 ~ 420nm (at least 100mW/cm<sup>2</sup>) wavelength for 1 minute.
- viii. After curing, the height of UV-glue should not exceed BKT\_LP for more than 0.6mm

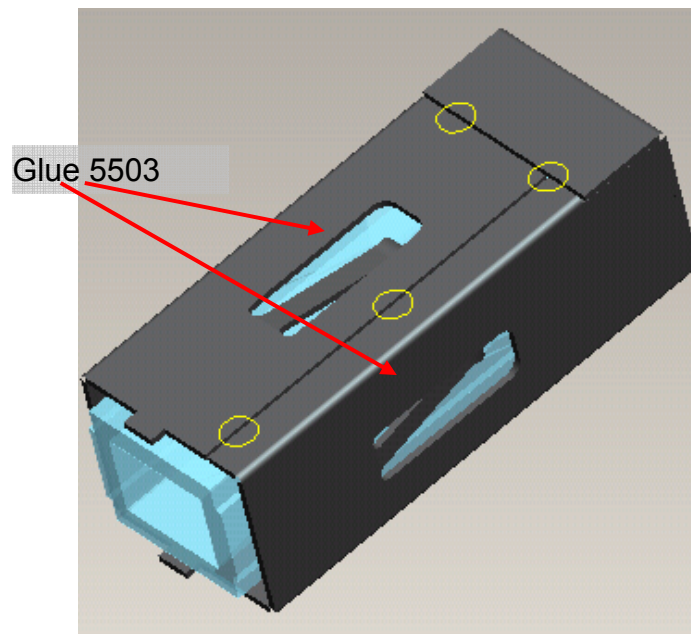

Fig. 5-3

#### 5.5 Assembly LP Module to HSG DMD

- i. Assembly two Overfill adjustment screw (8F.1A752.8R0) to HSG DMD (Fig. 5-4).  
\*\* Adjustment criteria refer to item 5.6.
- ii. Insert CLIP of BKT\_LP into the hole
- iii. Placed LP Module on LP datum and adjustment screw well, shown (Fig. 5-6).
- iv. Assembly “Baffle LP” first ( Figure 5-7)and make sure it hooks HSG DMD well  
~ Assembly Criteria was shown in Figure 5-7-2.
- v. Assembly “Clip\_LP” second (Fig. 4-8) and make sure it hooks HSG DMD well.  
( Figure 5-9).
- vi. Push two hook places to make sure that Baffle\_LP touches “BKT\_LP “well, don’t push the middle place of “Baffle\_LP”.

#### 5.6 Overfill Adjustment @ LP Module

Overfill Adjustment Criteria:

- i. Pre-assembly 2 adjusting screws. Criteria shown as Figure 5-10.
- ii. Alignment Sequence:
  - a. To adjust “Horizontal Adjustment Screw” firstly, then “Vertical Adjustment Screw”.
  - b. Refer to Figure 4-10.

For Overfill Re-adjustment:

1. Those 2 Adjustment Screws must be released closely to the “Pre-assembly” positions first. (defined in 4.6-i )

2. Follow adjustment steps shown in Item 4.6-ii.

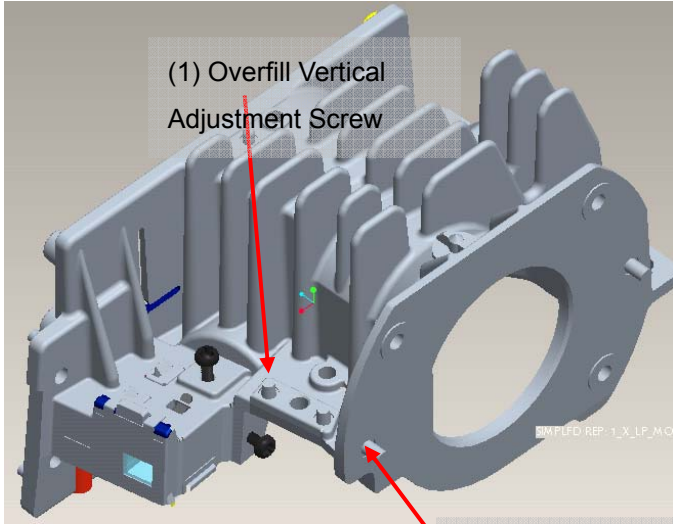

Fig.5-4 (1) Overfill Horizontal

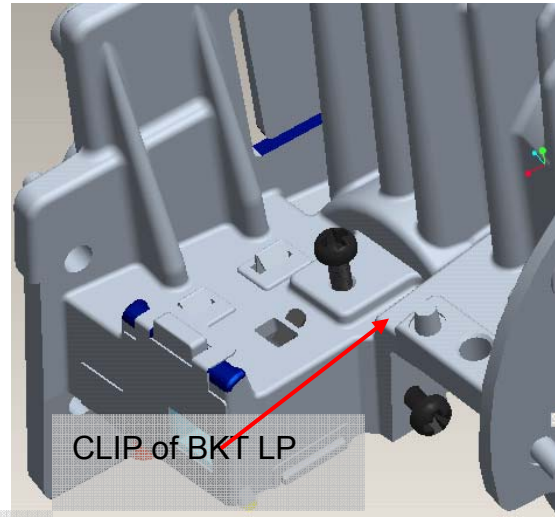

Fig. 5-5

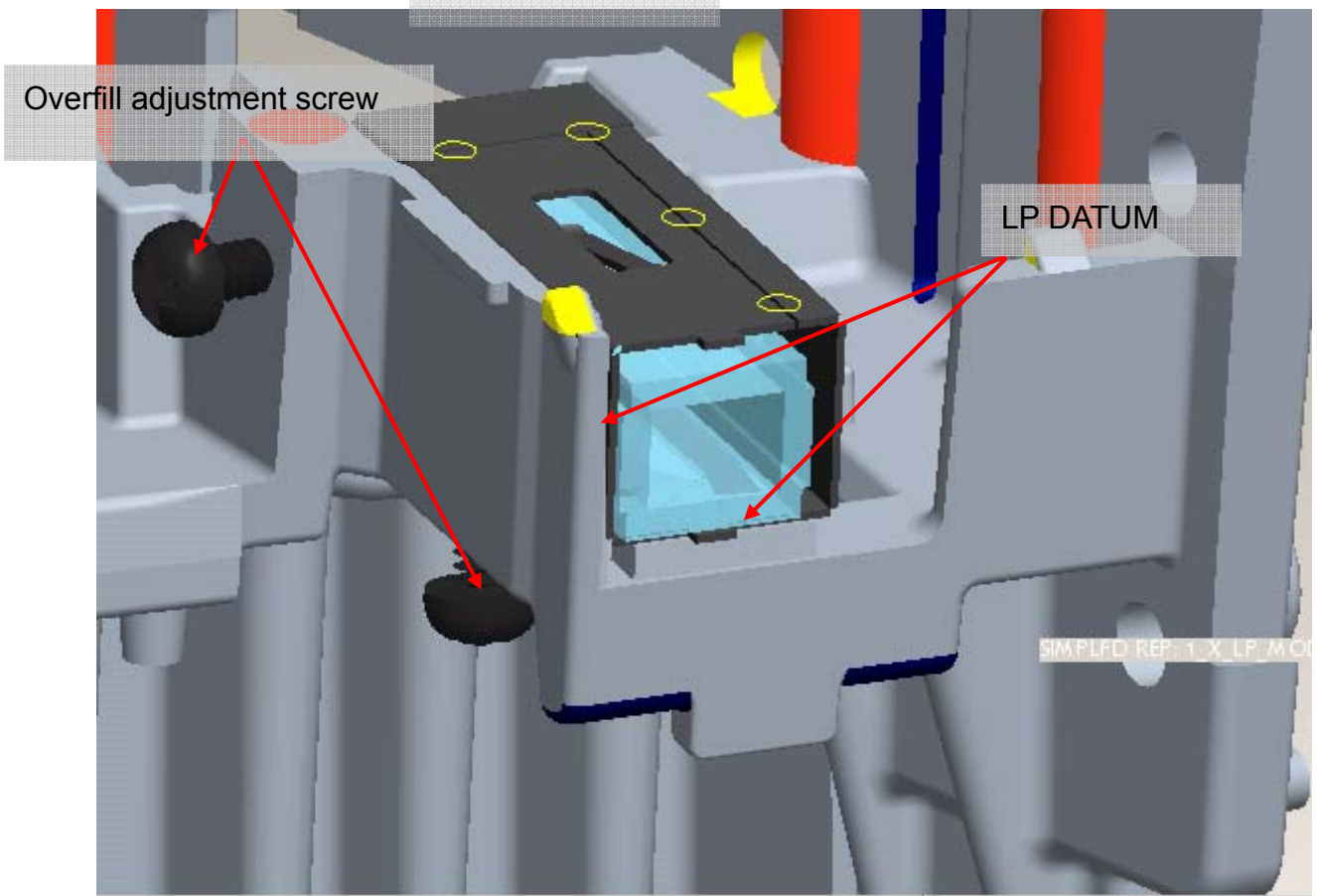

Fig. 5-6

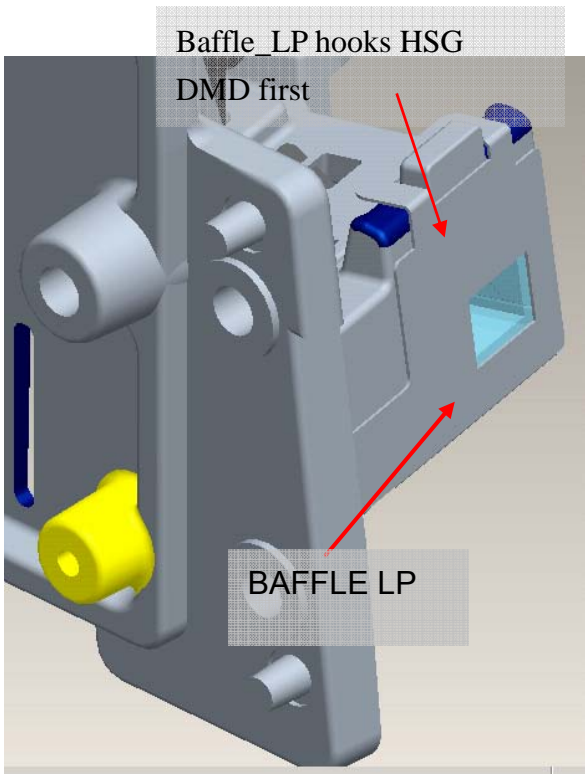

Fig. 5-7 (1)

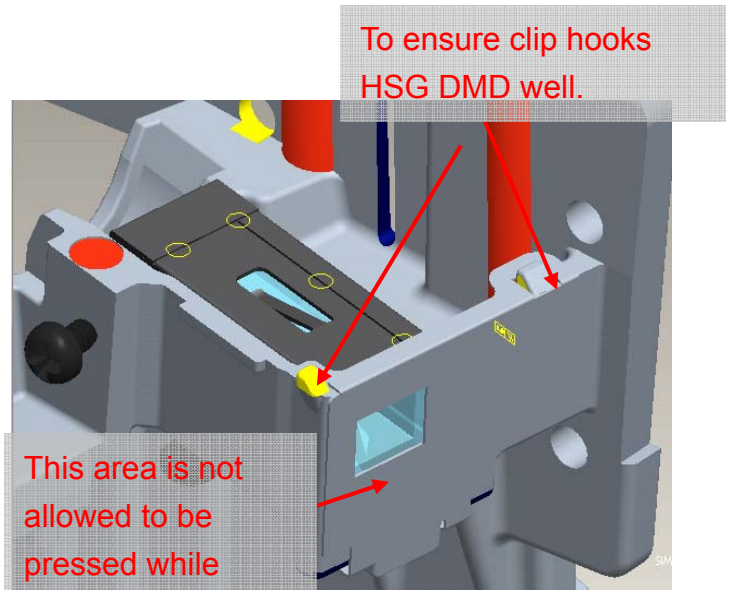

Fig. 5-7(2)

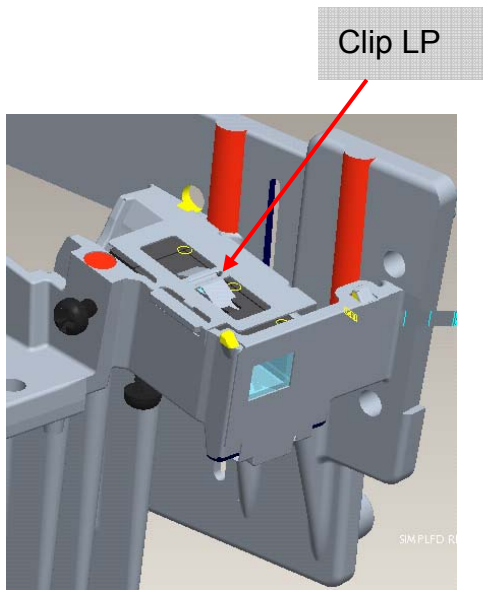

Fig. 5-8

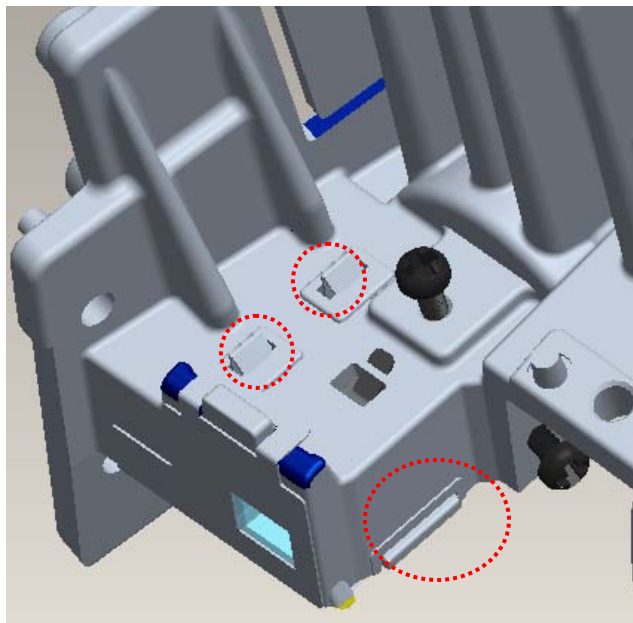

Fig. 5-9

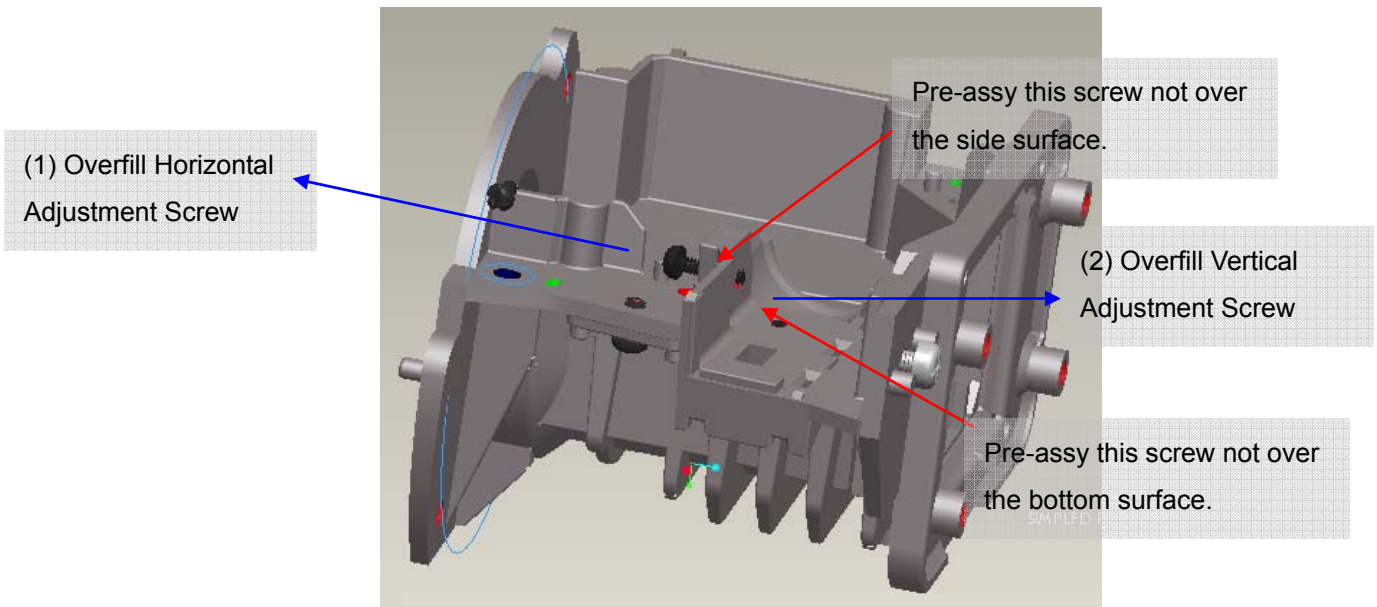

Fig. 5-10

## 6. Assembly HSG ILL Module

### 6.1 FM1 Assembly

- I. FM1 must be placed on datum surfaces well and breach of FM1 must be face to inside (Fig. 6-1)
- II. Insert the "CLIP of FM1" into the hole on the HSG ILL and make sure "CLIP of FM" hook on the HSG ILL well (Fig. 6-2)

### 6.2 CM Assembly

- III. Insert Clip CM Side and Clip CM Bottom first (Fig. 6-3,6-5)
- IV. Assemble CM to HSG ILL and to make CM contact three datum on the HSG ILL Well (Fig. 6-8)
- V. Assemble "CLIP of TOP" to the HSG ILL (Fig. 6-9)
- VI. To check and make sure "CLIP of CM" hooks the HSG ILL very Well (Fig. 6-4, 6-6,6-10)
- VII. Assemble Baffle Stop to HSG ILL and fasten screw (Fig. 6-10)
- VIII. Paste Sponge tube AL on cannellure of HSG ILL(Fig. 6-11)



Breach of FM1

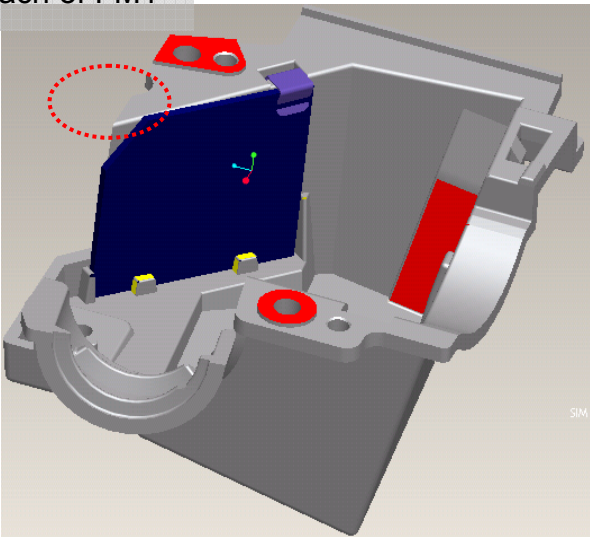

Fig. 6-1

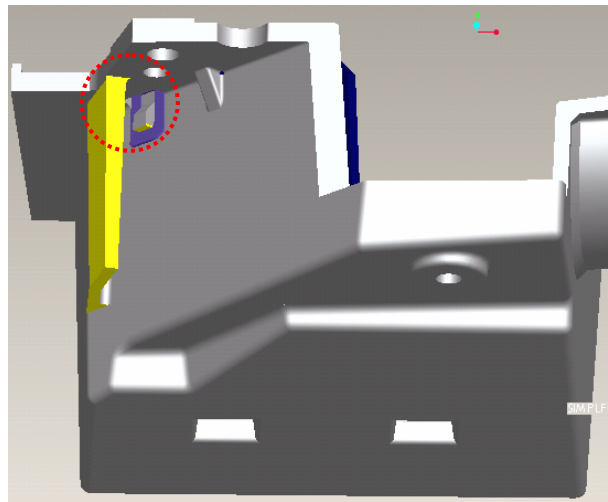

Fig. 6-2

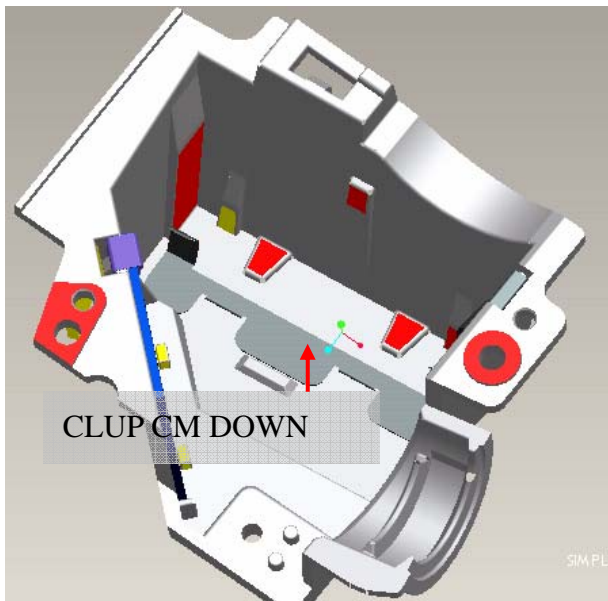

Fig. 6-3

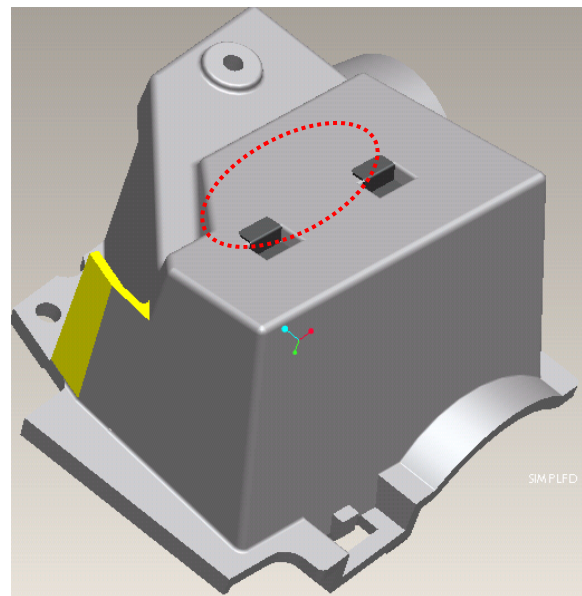

Fig. 6-4

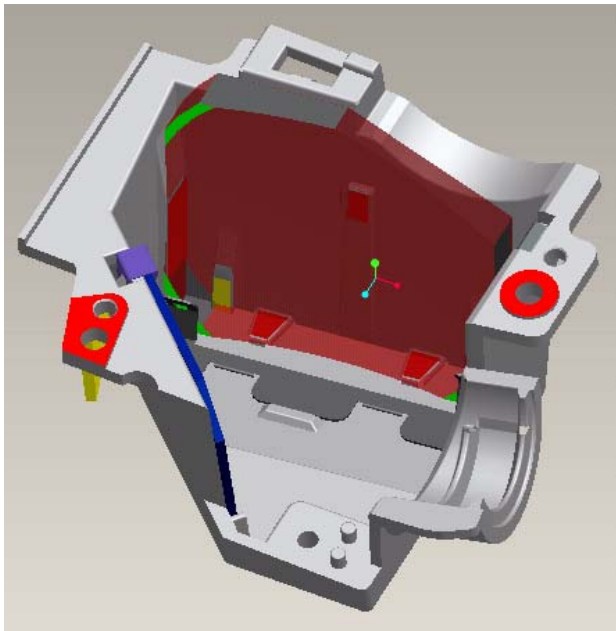

Fig. 6-5

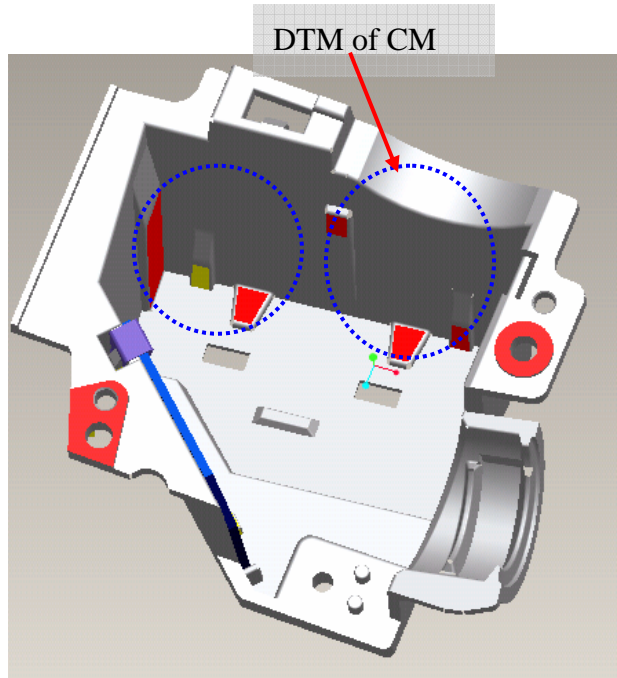

Fig. 6-6

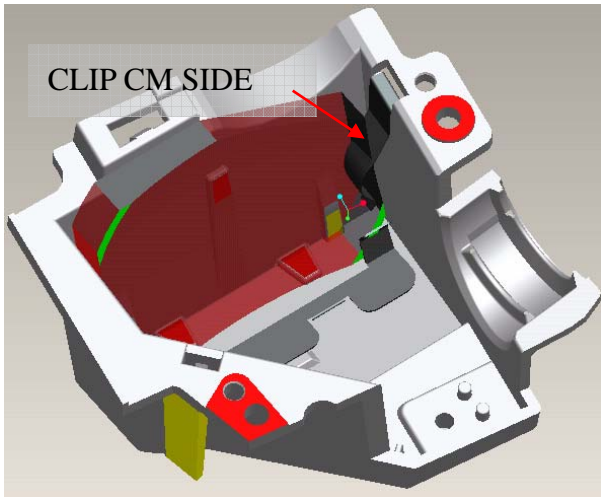

Fig. 6-7

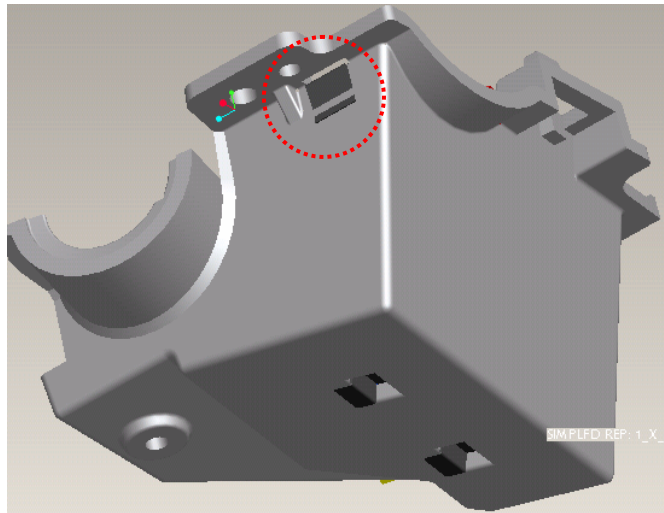

Fig. 6-8

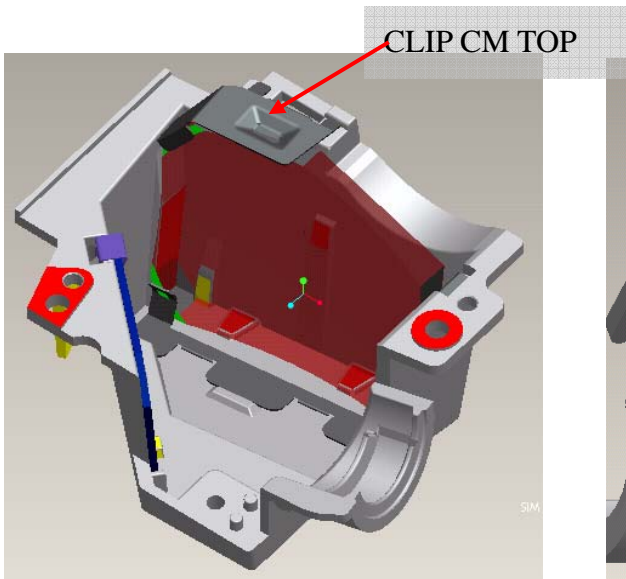

Fig. 6-9

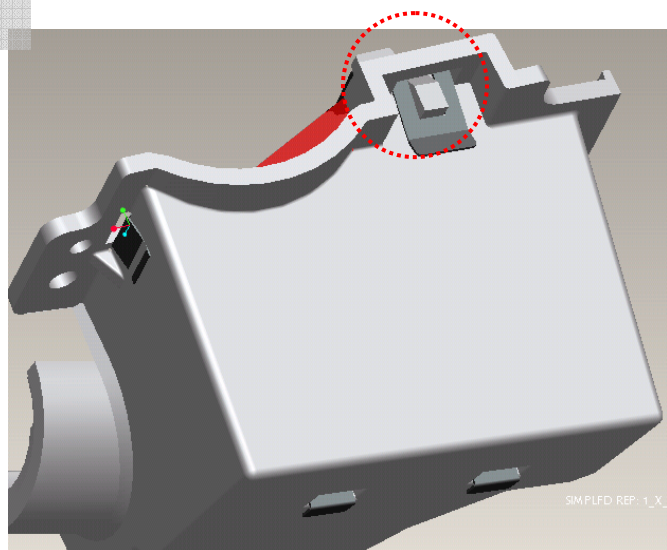

Fig. 6-10

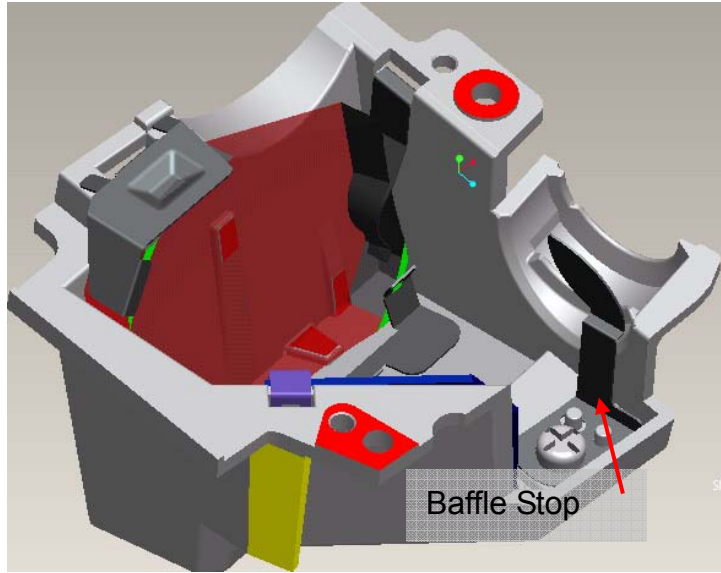

Fig. 6-10

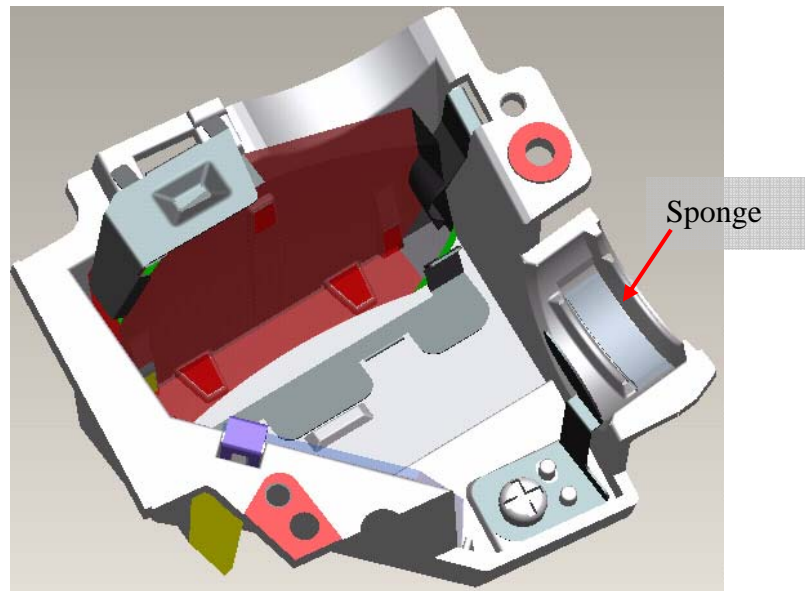

Fig. 6-11

## 7. AL, HSG ILL and HSG DMD Assembly:

7.1 Placed “AL” on the HSG DMD .The “raised surface” of “AL” shall toward “DMD direction” (Fig. 7-1)

7.2 Assemble” HSG ILL Module” to HSG DMD and cover over on “AL” (Fig. 7-2)

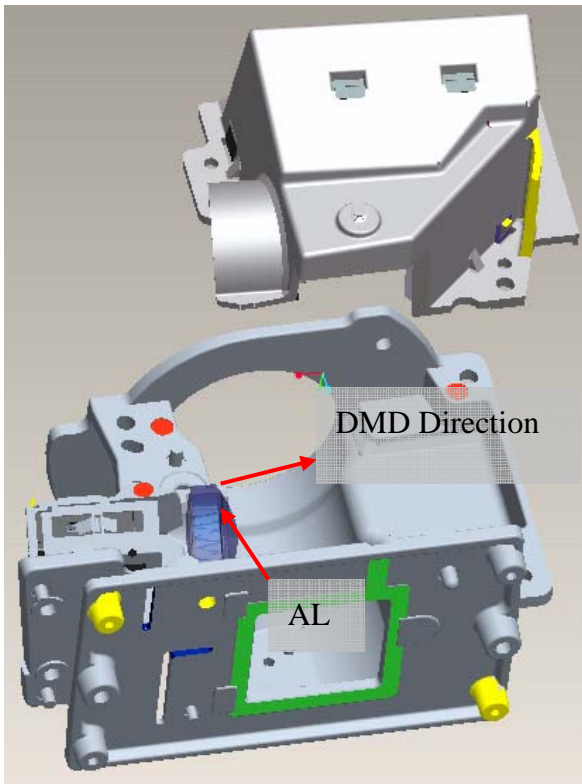

Fig. 7-1

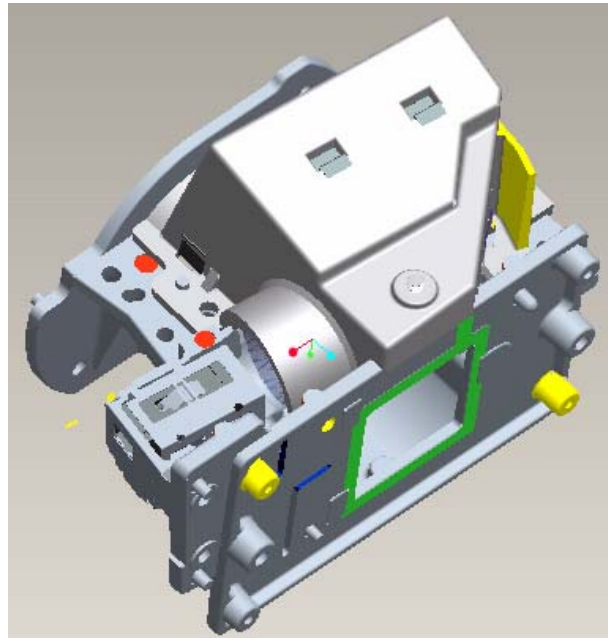

Fig. 7-2

## 8. DMD and Chip B/D Module

8.1. Judge Chip B/D and DMD alignment keying first (Fig. 8-1, 8-2)

8.2. Alight keying and Assemble DMD to Chip B/D (Fig. 8-3)

8.3. Push DMD slightly and use screwdriver rotate button to lock DMD on Chip B/D (Fig. 8-4)

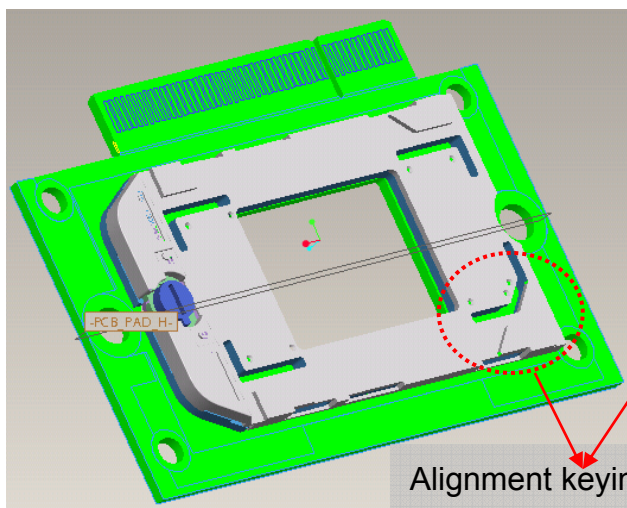

Fig. 8-1

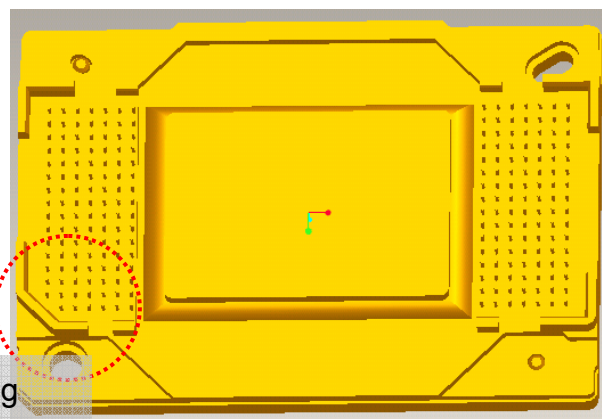

Fig. 8-2

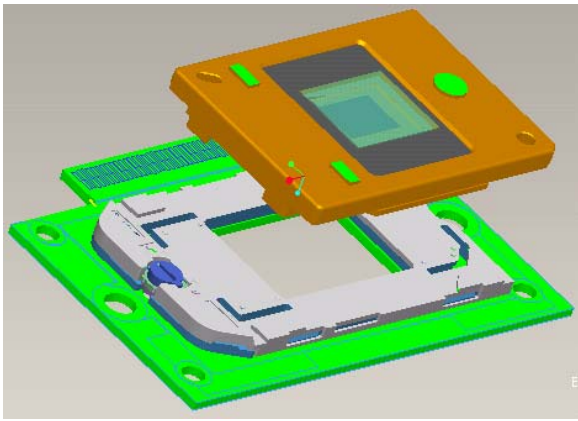

Fig. 8-3

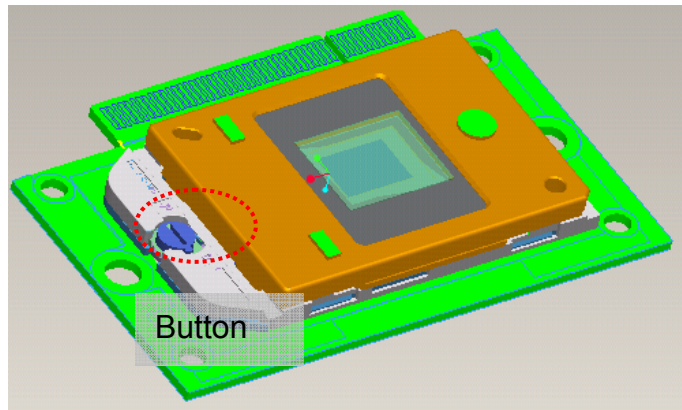

Fig. 8-4

### 9. AL , HSG ILL and HSG DMD Assembly:

9.1 Placed “AL” on the HSG DMD .The “raised surface” of “AL” shall toward “DMD direction” (Fig. 9-1)

9.2 Assemble” HSG ILL Module” to HSG DMD and cover over on “AL” (Fig. 9-2)

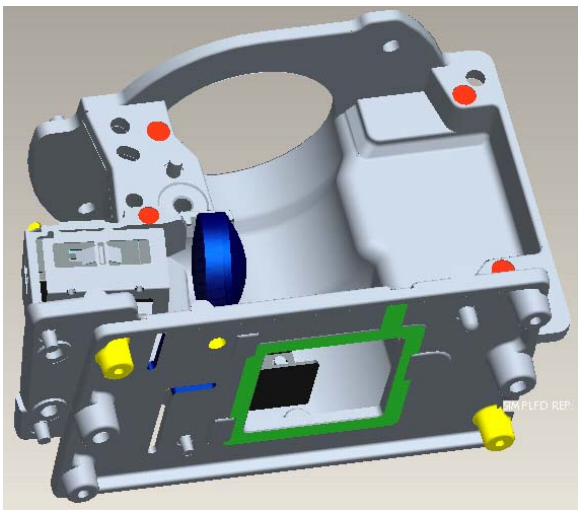

Fig. 9-1

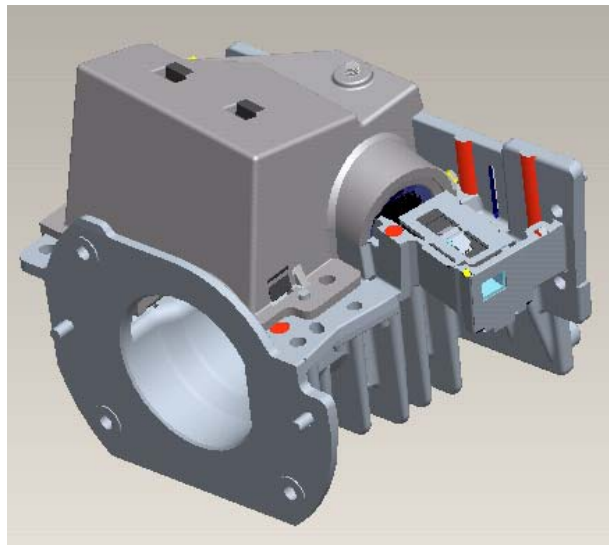

Fig. 9-2

## 10. Assembly OP ENG

10.1 Assemble Baffle DMD to HSG DMD (Fig. 10-1)

10.2 Assemble Chip B/D Module to HSG DMD and fasten the screw(Fig. 10-2)

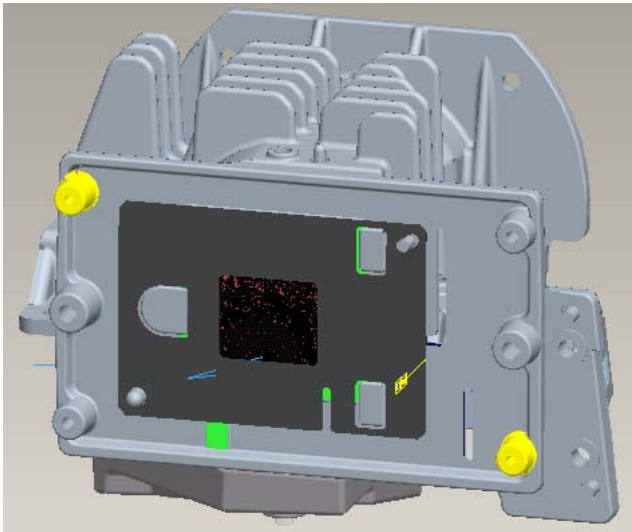

Fig. 10-1

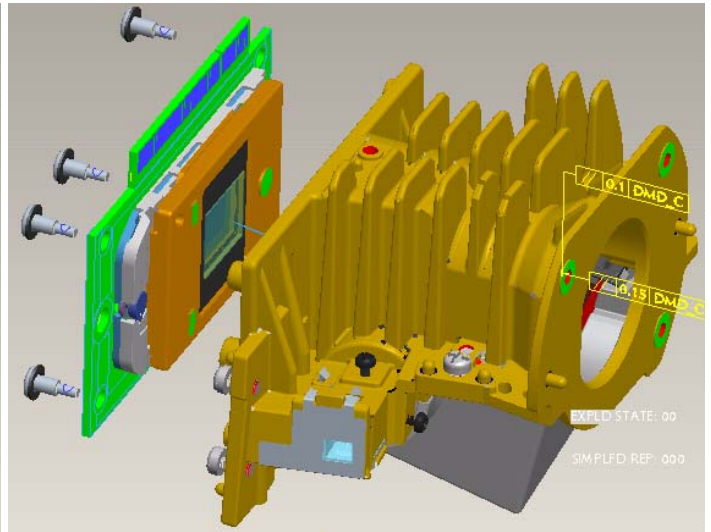

Fig. 10-2

10.3 Fasten shoulder screw Sequence as blow (Fig. 10-3)

- i. Pre-fastening Sequence: [ 1 ] - [ 2 ] - [ 3 ] - [ 4 ]
- ii. Fastening Sequence [ 2 ] - [ 1 ] - [ 4 ] - [ 3 ]
- iii. Screw Torque must be confirmed to be 2.5 kg-cm.

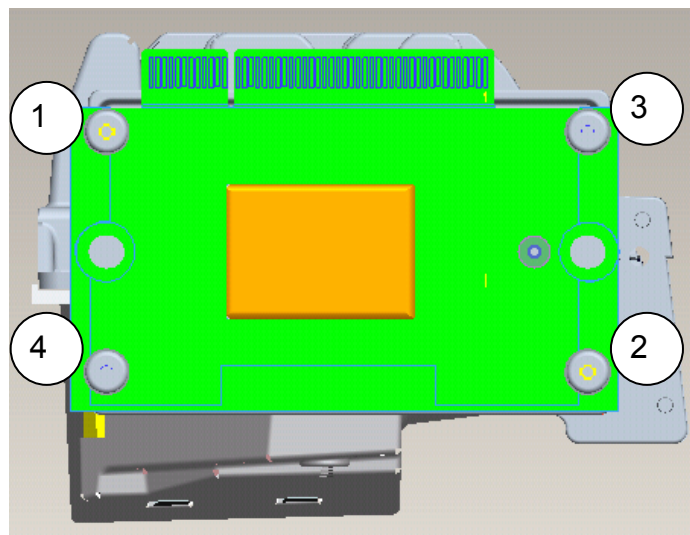

Fig. 10-3

10.4 Assemble PL Lens and fasten screw (Fig. 10-4)

10.5 Assemble Ring Zoom and fasten screw then assembly Ring Focus(Fig. 10-5)

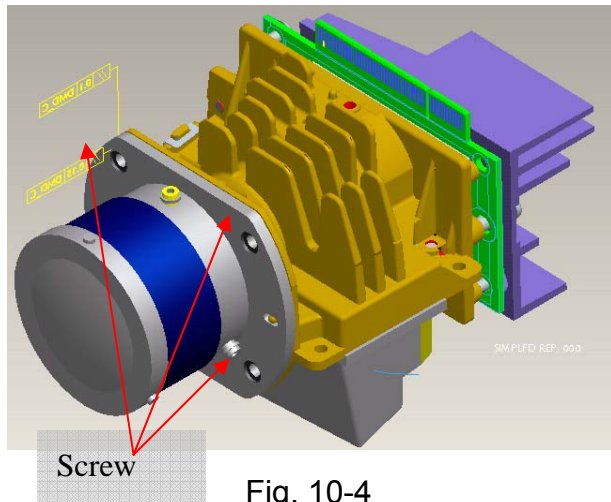

Fig. 10-4

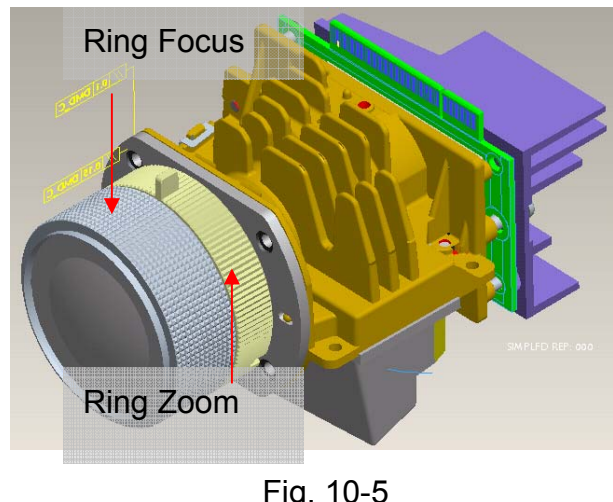

Fig. 10-5

10.6 Assemble CW Module and fasten screw (Fig. 10-6)

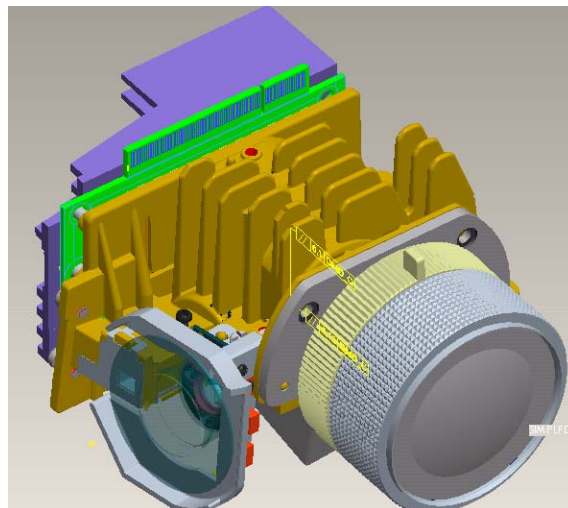

Fig. 10-6

10.7 Assemble BKT Link and Shield CW (Fig. 10-7)

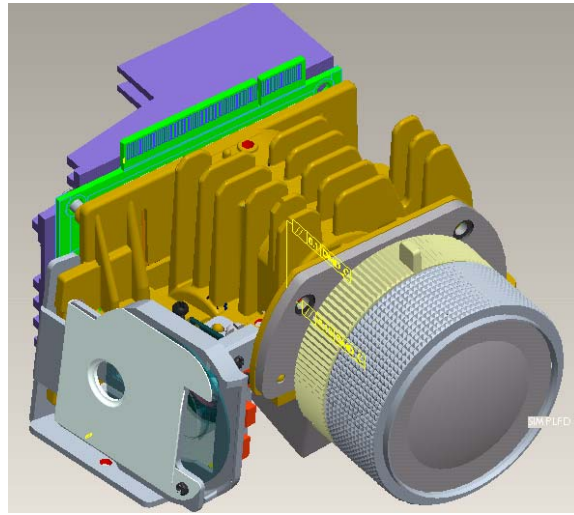

Fig. 10-7



10.8-1 Assemble Thermal pad and Hest-sink

10.8-2 Fasten "Assy spring screw" Sequence as blow (Fig.10-8)

Pre-fastening Sequence: [ 1 ] - [ 2 ]

Fastening Sequence [ 2 ] - [ 1 ]

Screw Torque must be confirmed to be 6 kg-cm.

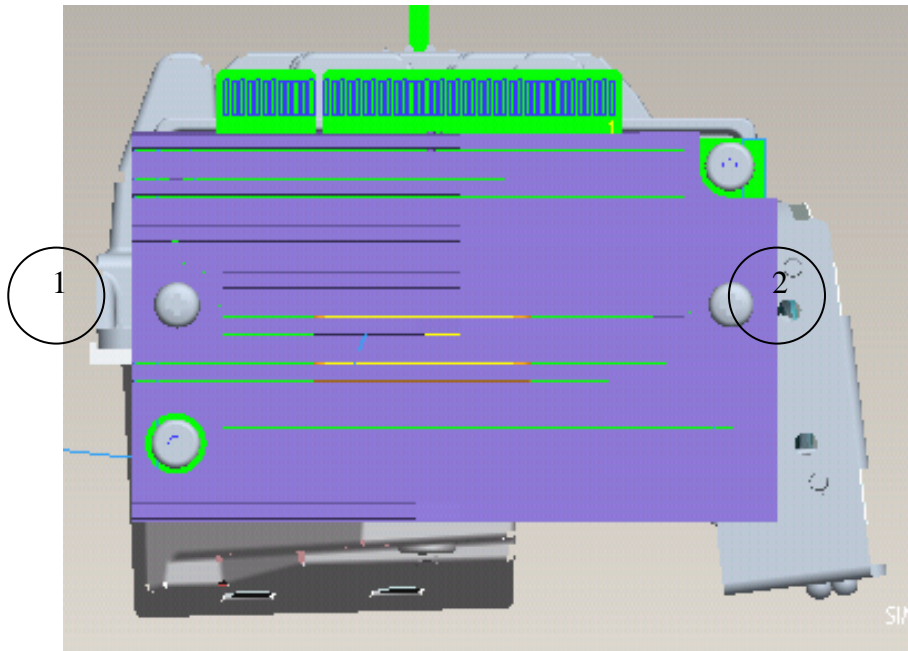

Fig. 10-8

10.9 Assemble Lamp Module and fasten screw (Fig. 10-9)

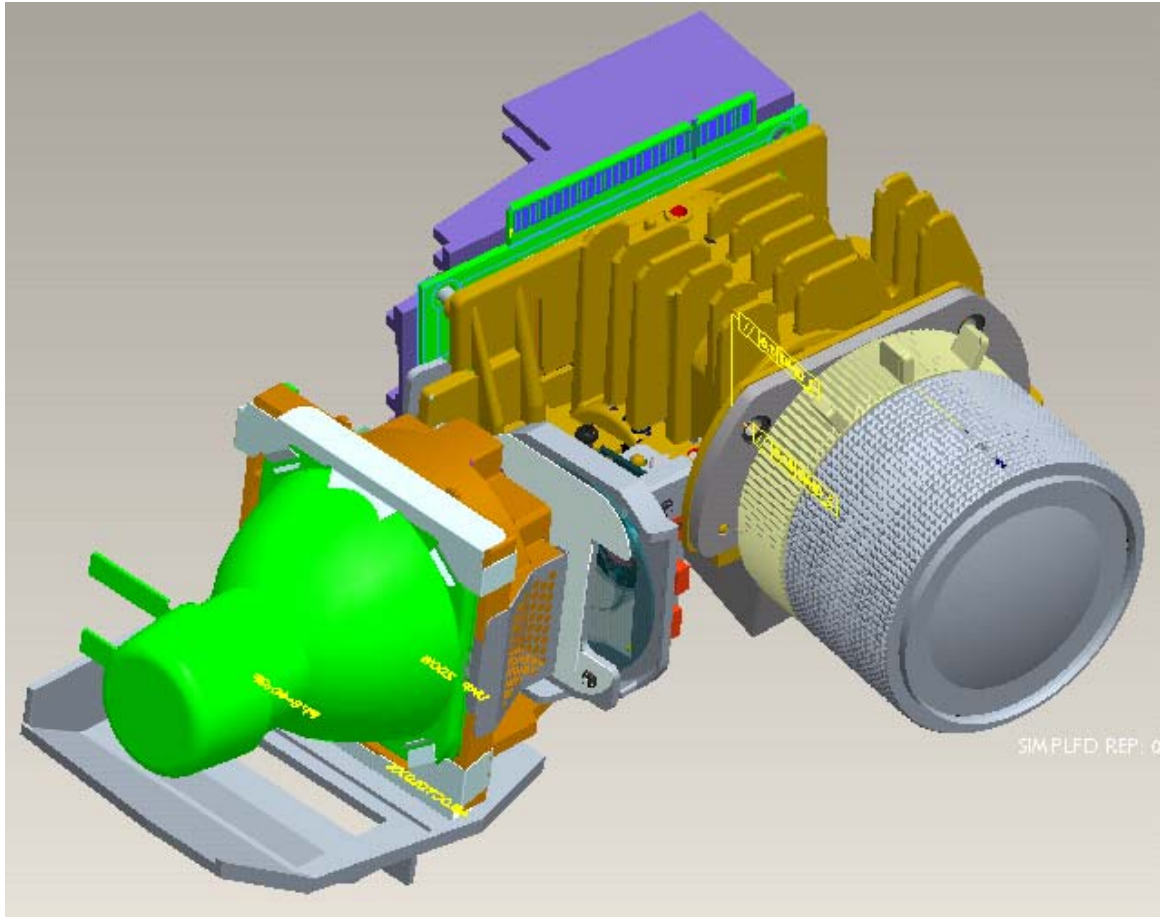
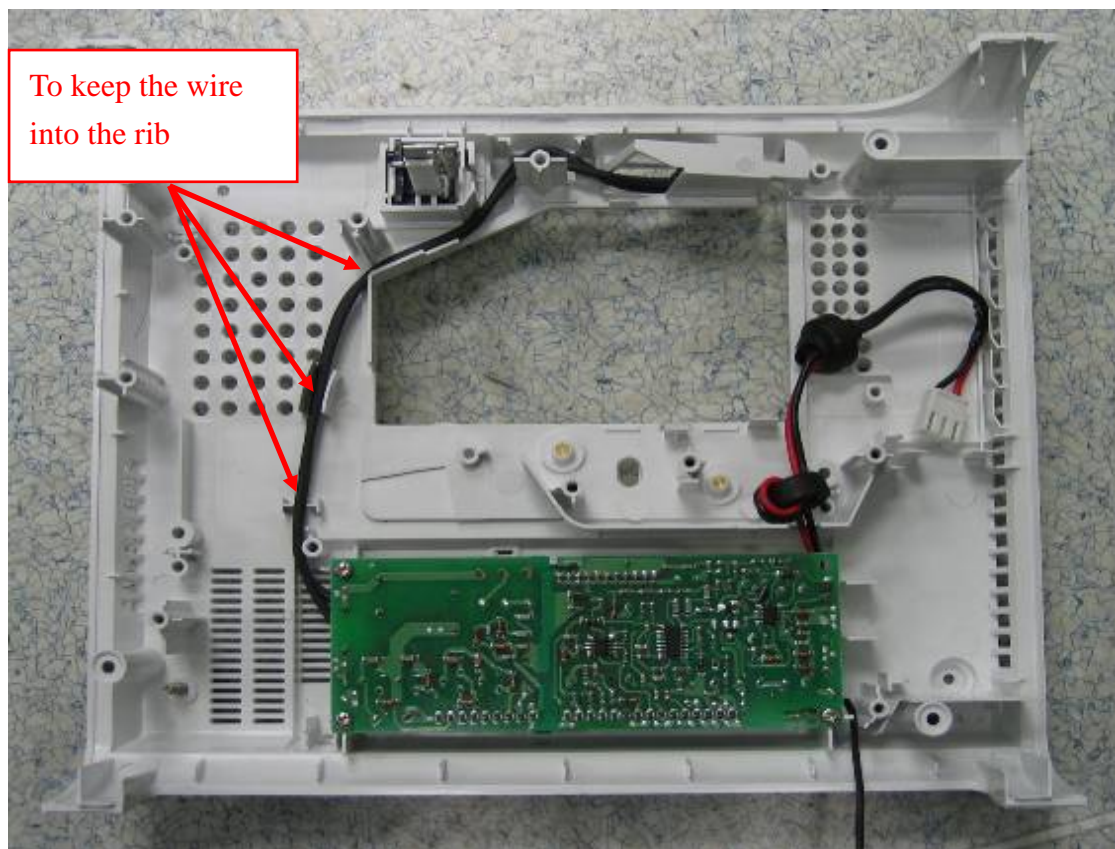

Fig. 10-9

### 3. Mechanical Assembly Concern

- 3.1. Ballast assembly and lamp wire alignment
- 3.2. Blower module assembly and blower wire alignment
- 3.3. OPT engine assembly and blower wire alignment
- 3.4. Power board assembly and power board wire alignment
- 3.5. Lamp box assembly
- 3.6. Power board shielding assembly and power board grounding wire alignment
- 3.7. Main board assembly and ballast wire alignment
- 3.8. Main board shielding assembly and wire alignment
  - a. Main board shielding assembly
  - b. C/W FPC, C/W sensor wire and blower wire alignment
  - c. Front IR wire alignment
- 3.9. Rear cover assembly and speaker wire alignment
- 3.10. Twin fans assembly and wire alignment.
- 3.11. IR board assembly
- 3.12. Upper case, inlet cover and outlet cover assembly

#### 3.1. Ballast assembly and lamp wire alignment



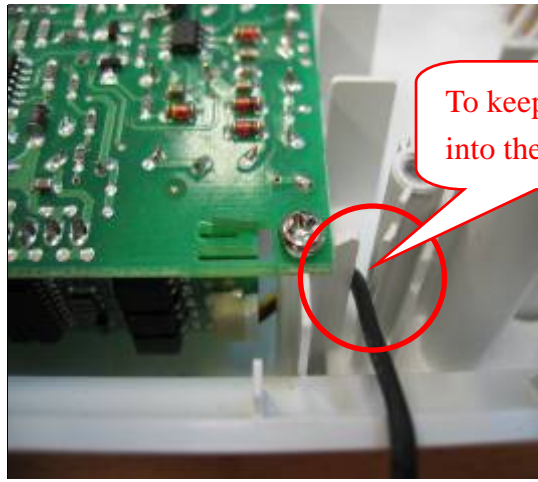
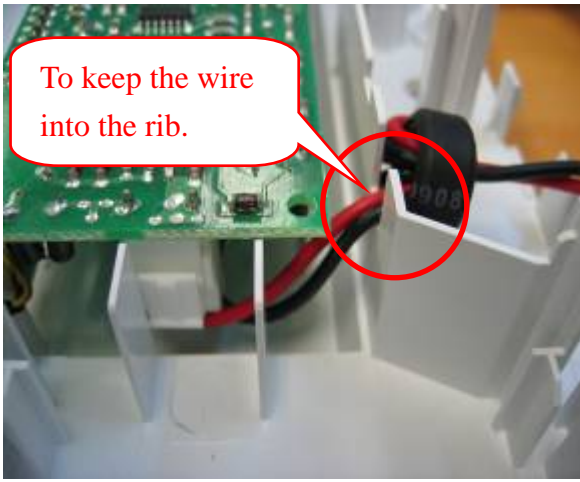

3.2. Blower module assembly and blower wire alignment

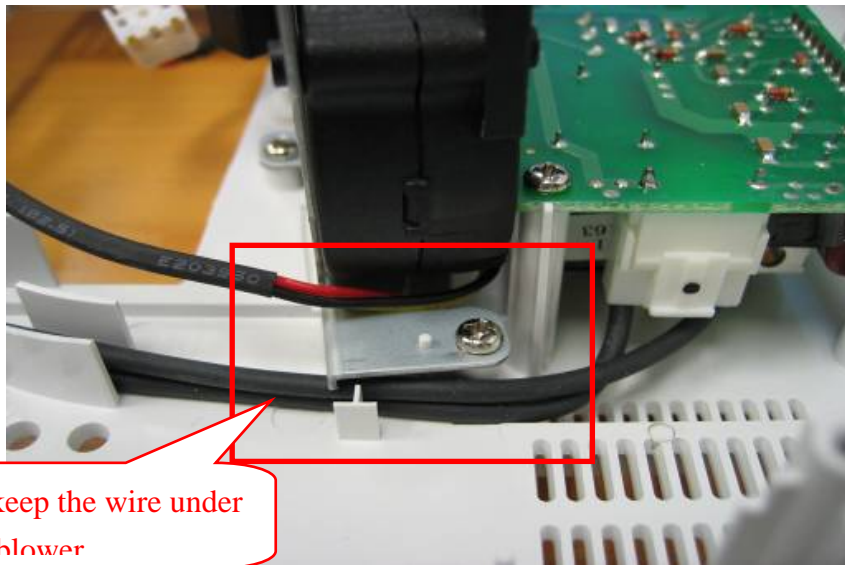

### 3.3. OPT engine assembly and blower wire alignment

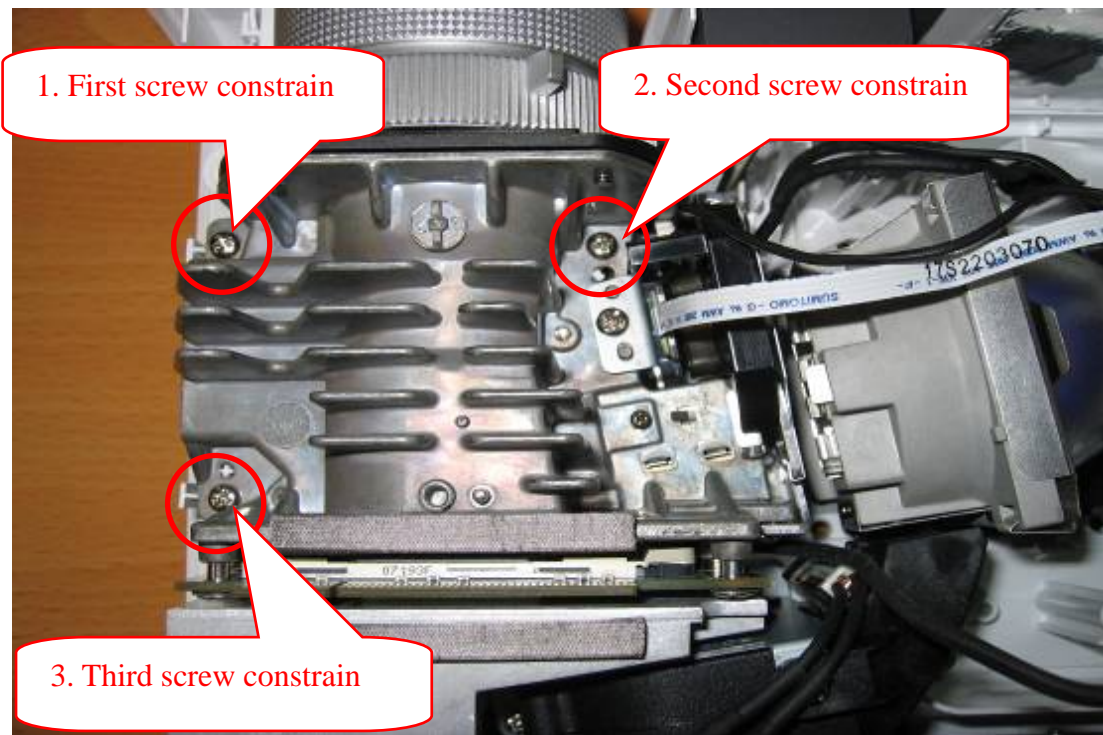

### 3.4. Power board assembly and power board wire alignment

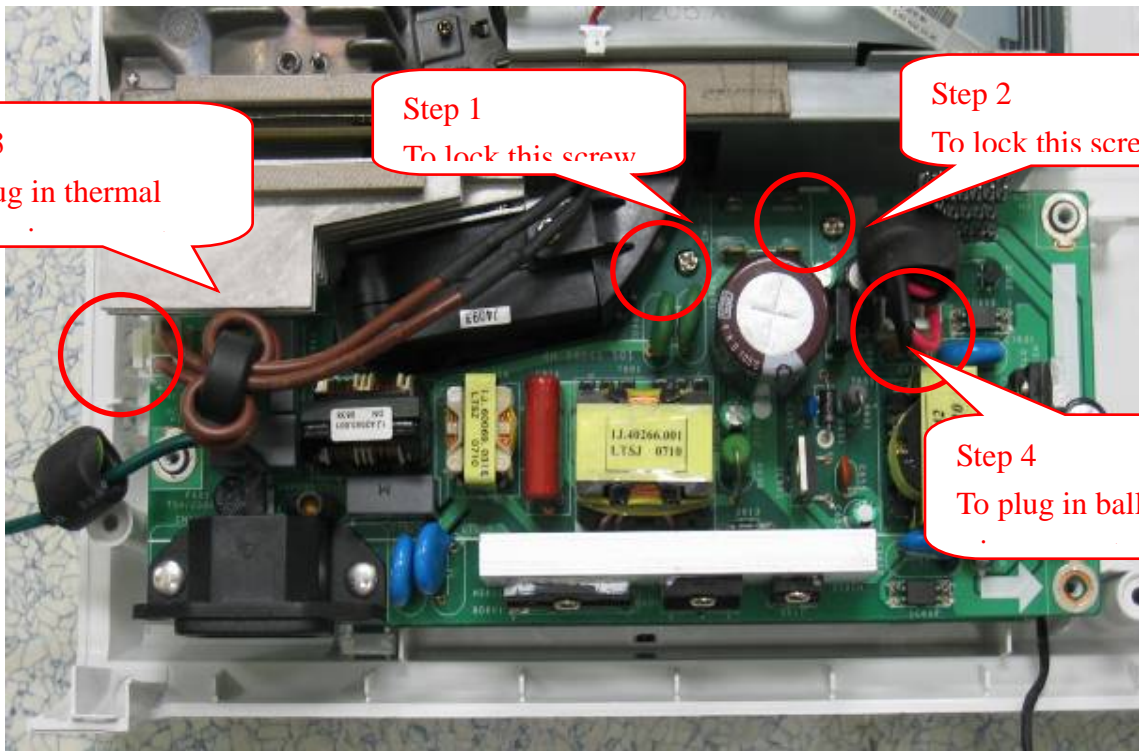

Step 3  
To plug in thermal  
.....

Step 1  
To lock this screw

Step 2  
To lock this screw.

Step 4  
To plug in ballast  
.....

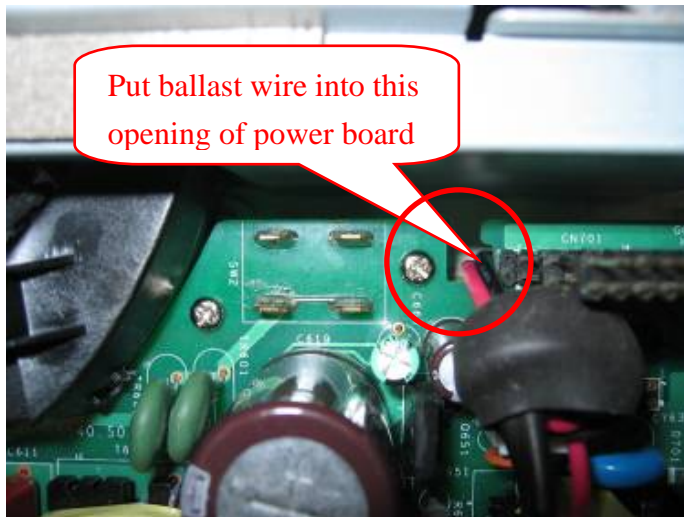

Put ballast wire into this  
opening of power board

### 3.5. Lamp box assembly

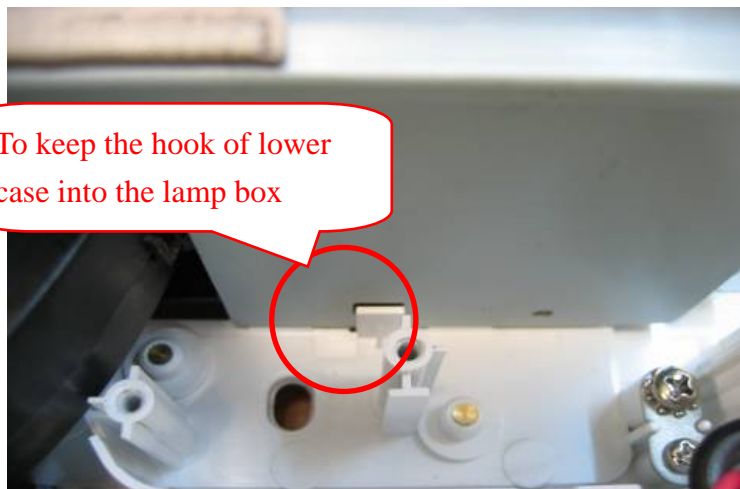

To keep the hook of lower  
case into the lamp box

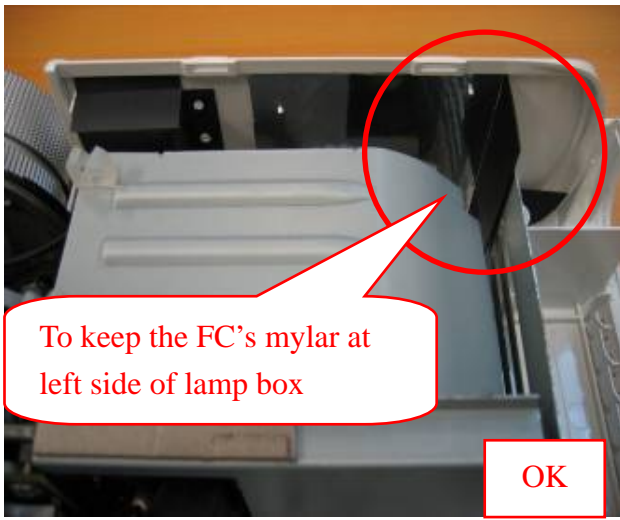

3.6. Power board shielding assembly and power board grounding wire alignment

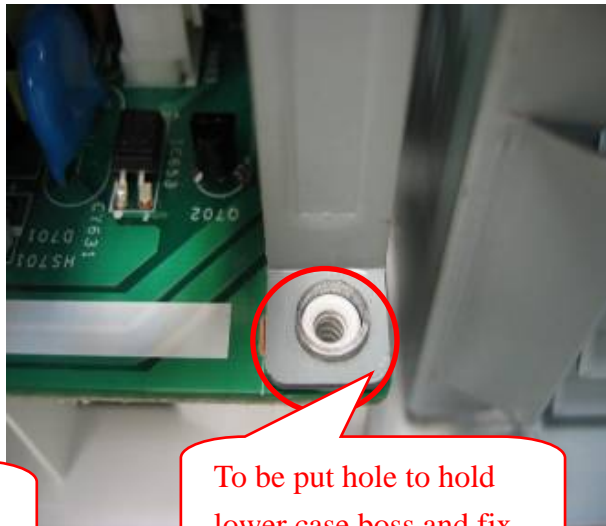
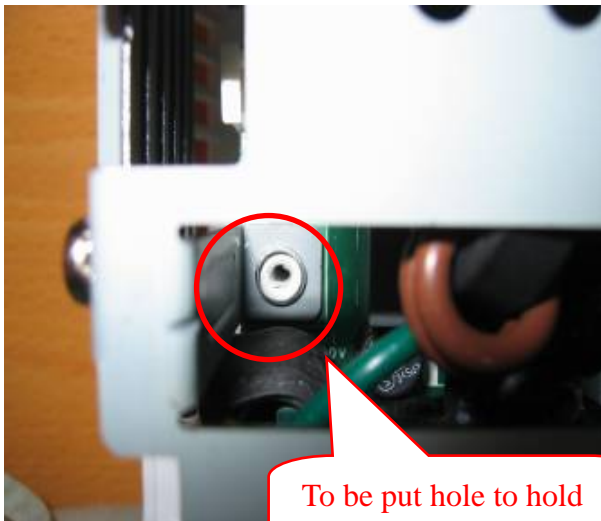
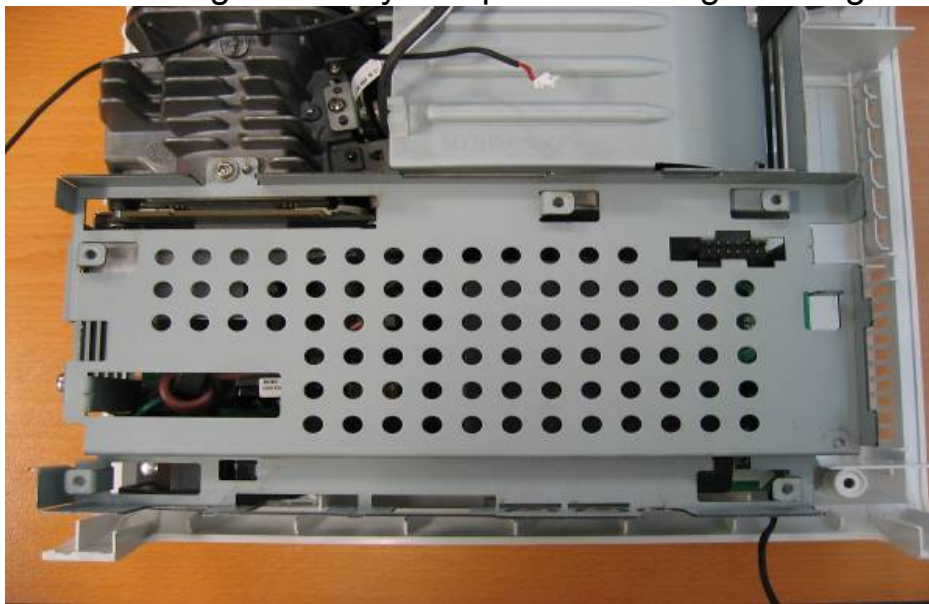

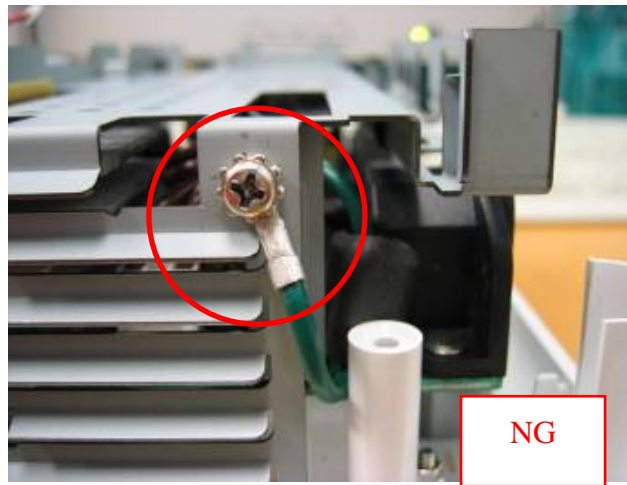
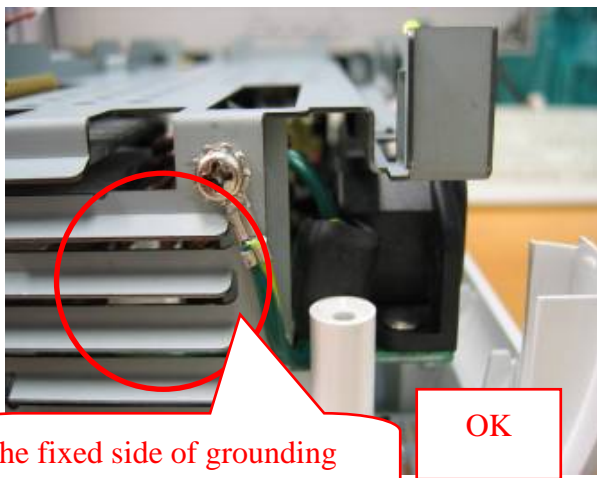
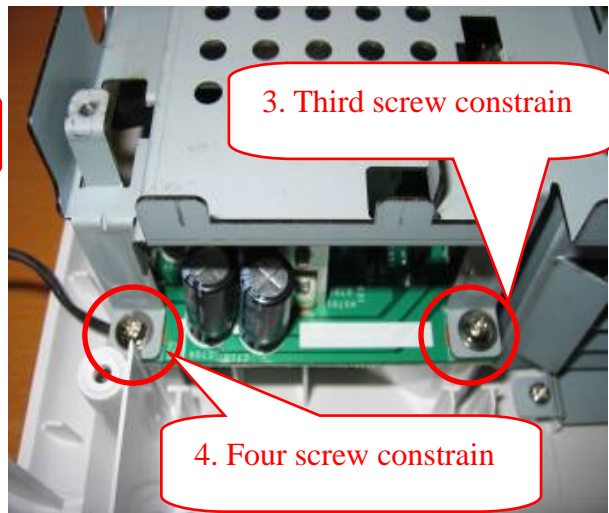
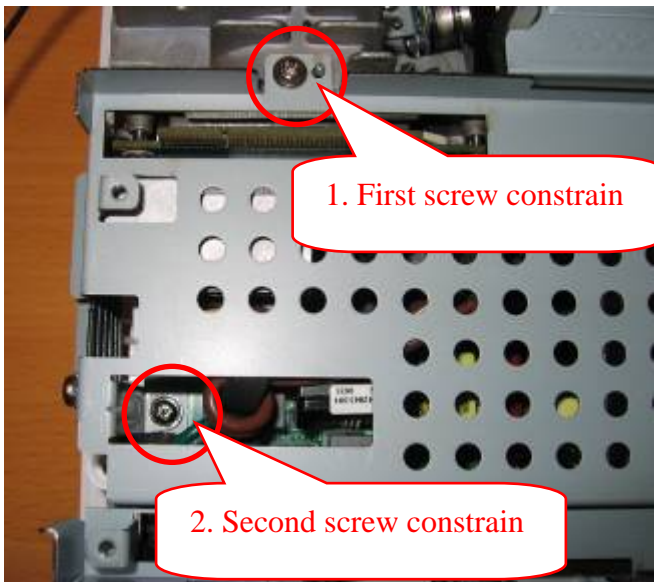

The fixed side of grounding wire must be take care

### 3.7. Main board assembly and ballast wire alignment

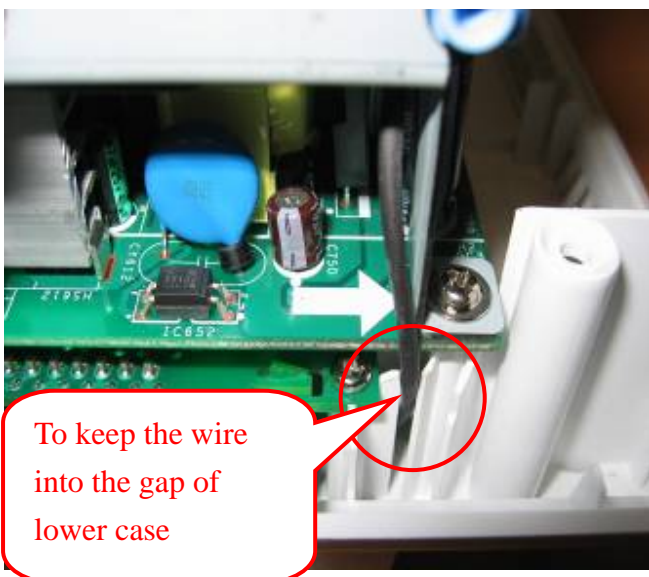



### 3.8. Main board shielding assembly and wire alignment

#### a. Main board shielding assembly

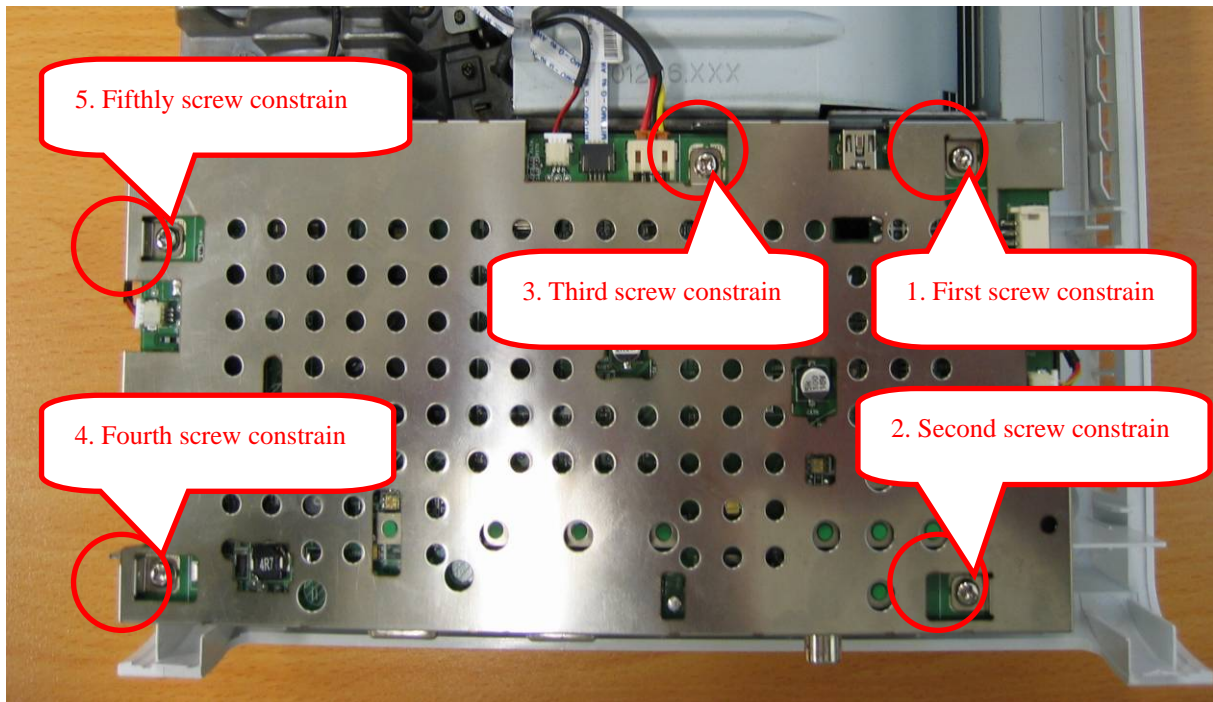
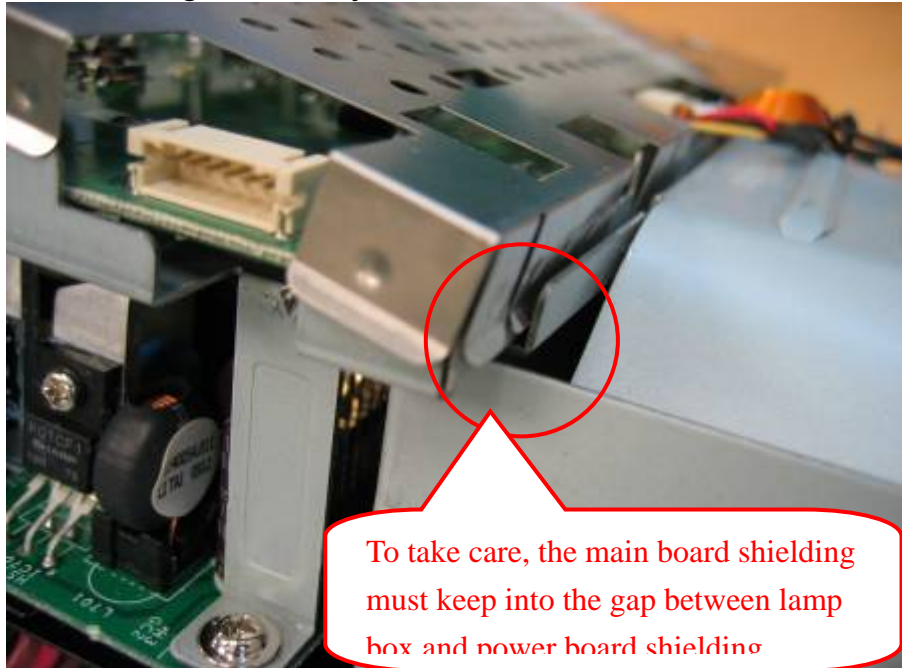

b. C/W FC, C/W sensor wire & blower wire alignment

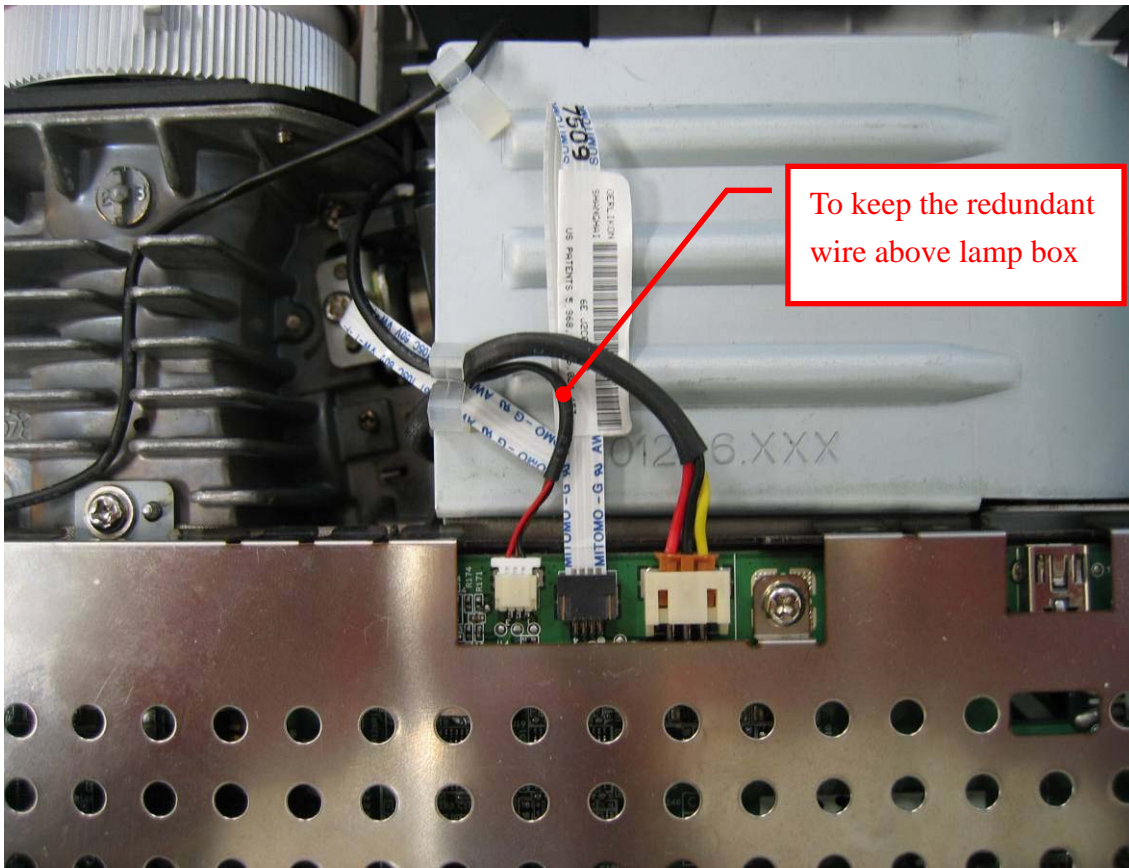

c. Front IR wire alignment

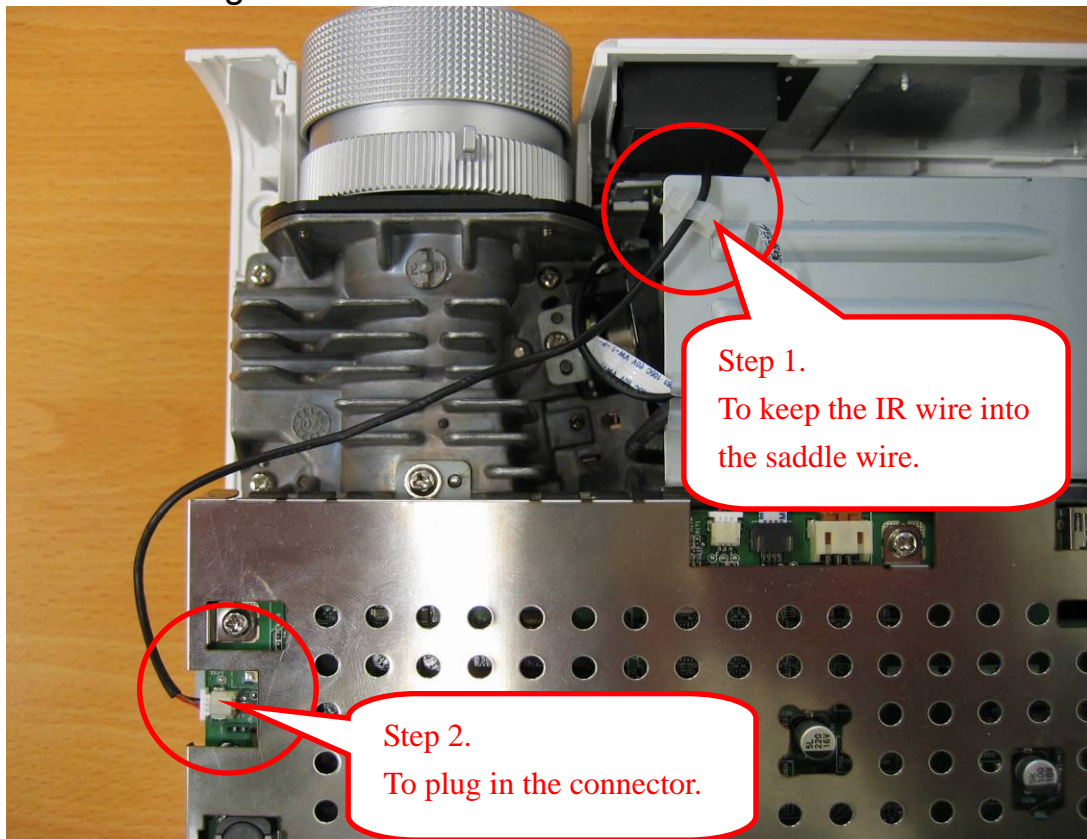

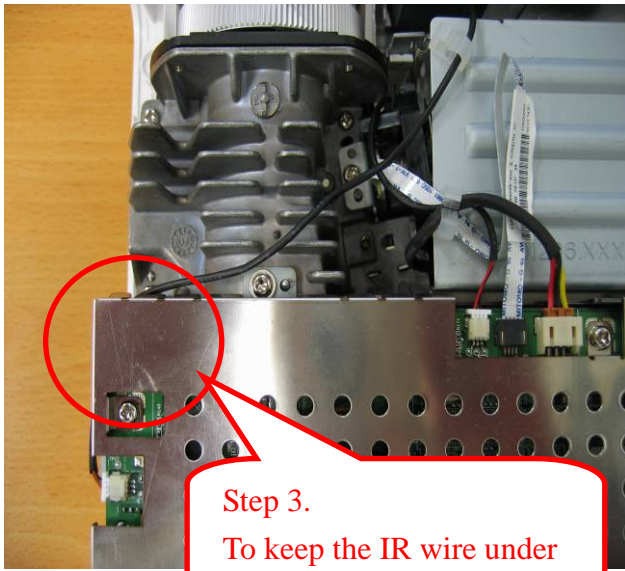

Step 3.  
To keep the IR wire under  
the cover board shielding

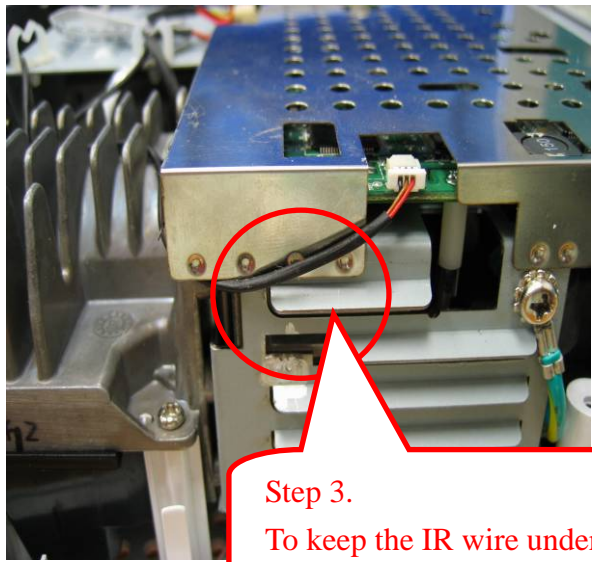

Step 3.  
To keep the IR wire under  
the

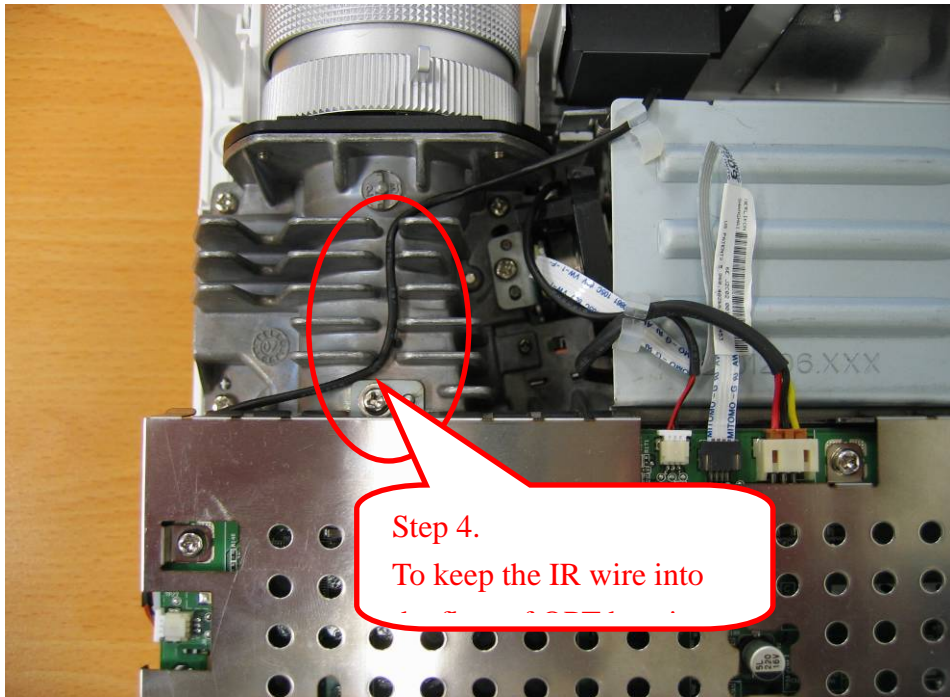

Step 4.  
To keep the IR wire into

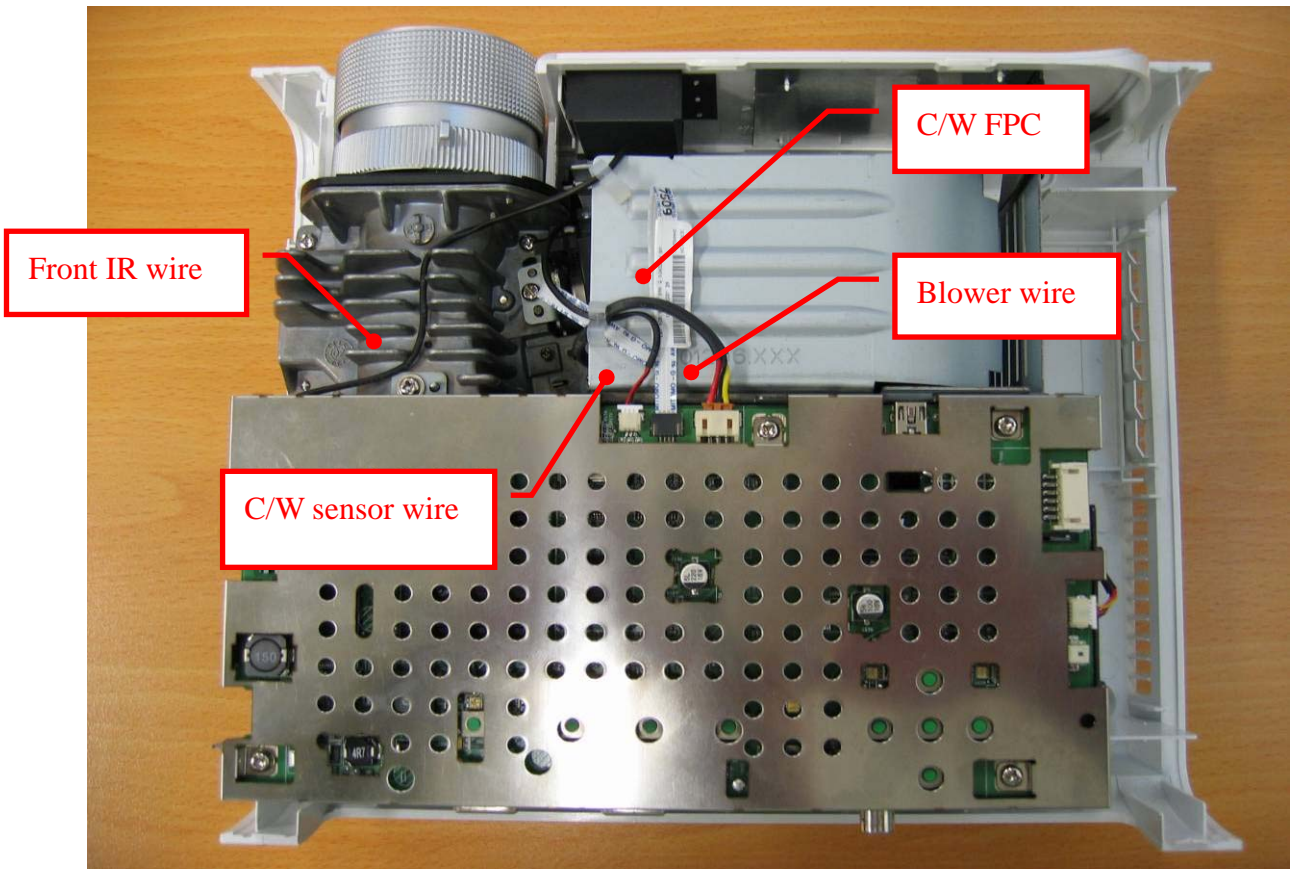

### 3.9. Rear cover assembly and speaker wire alignment

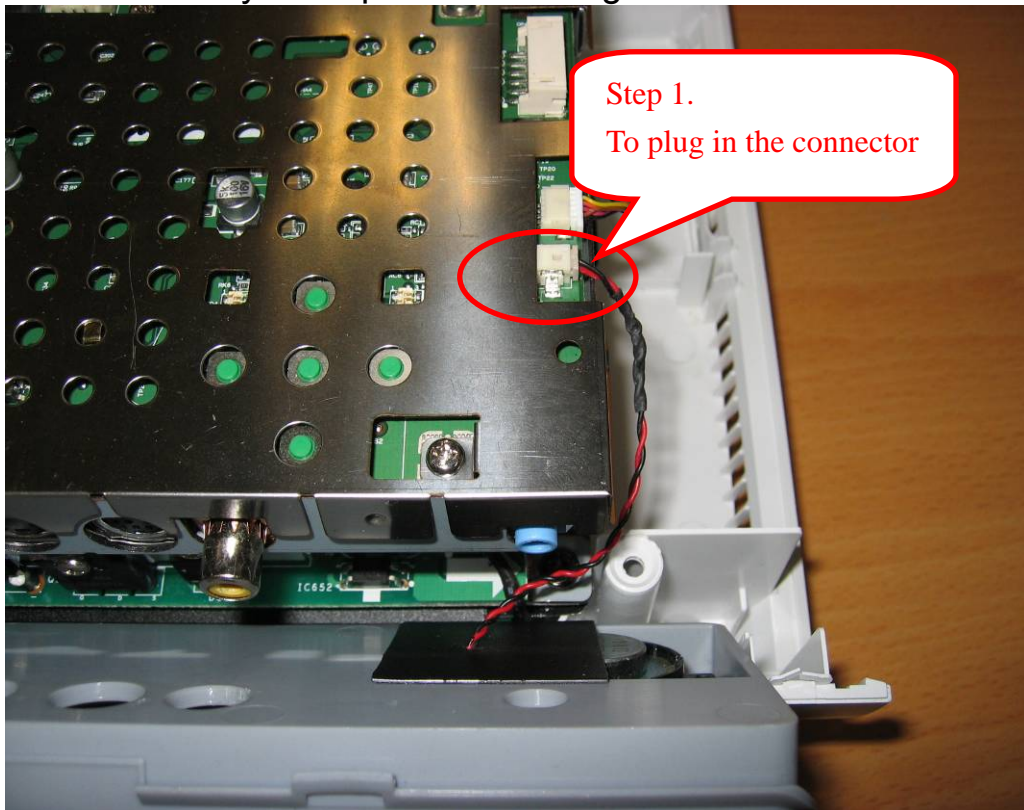

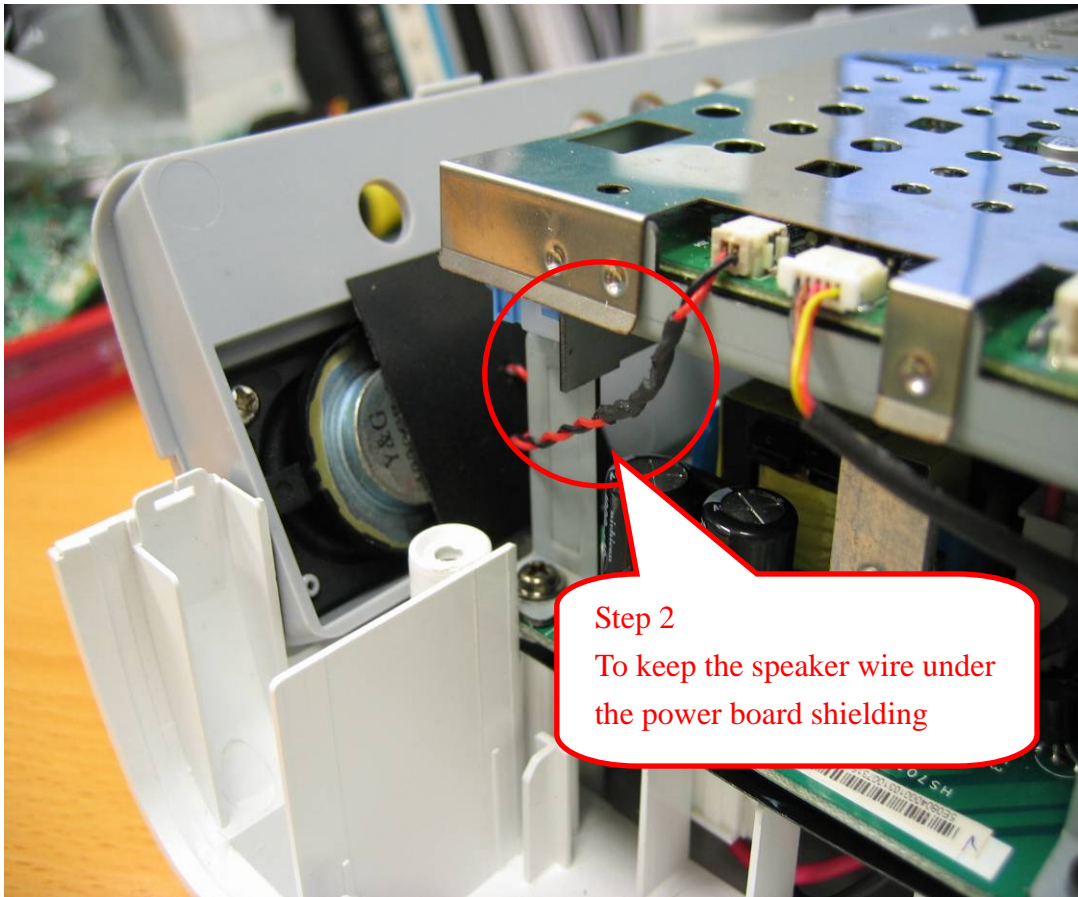

Step 2  
To keep the speaker wire under  
the power board shielding

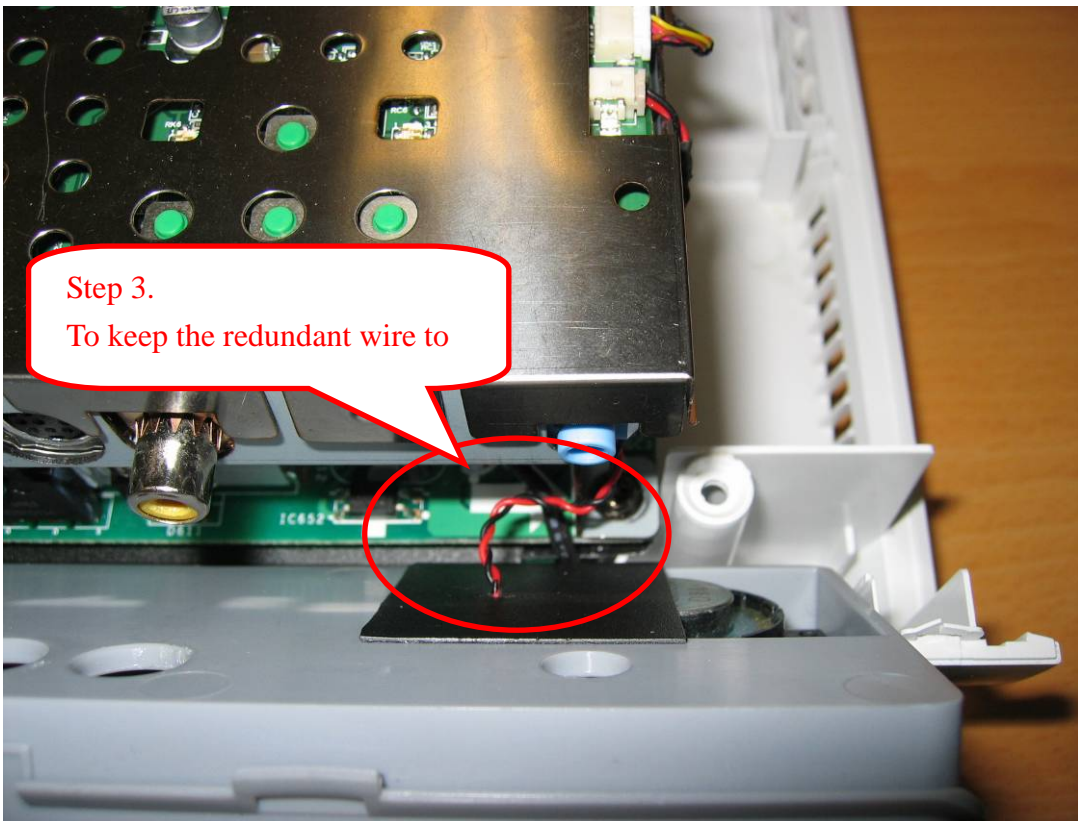

Step 3.  
To keep the redundant wire to

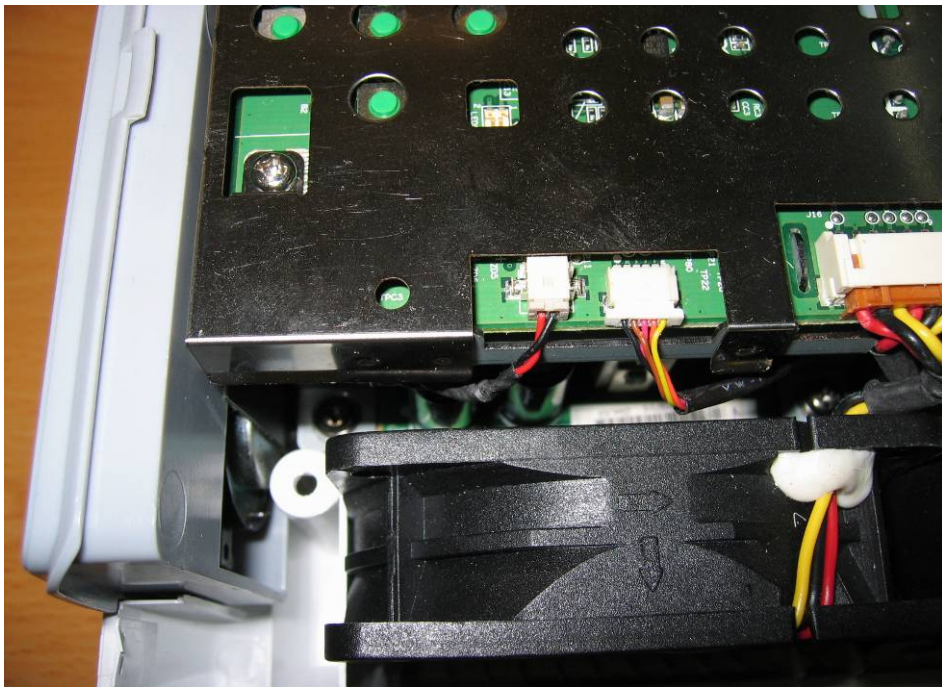
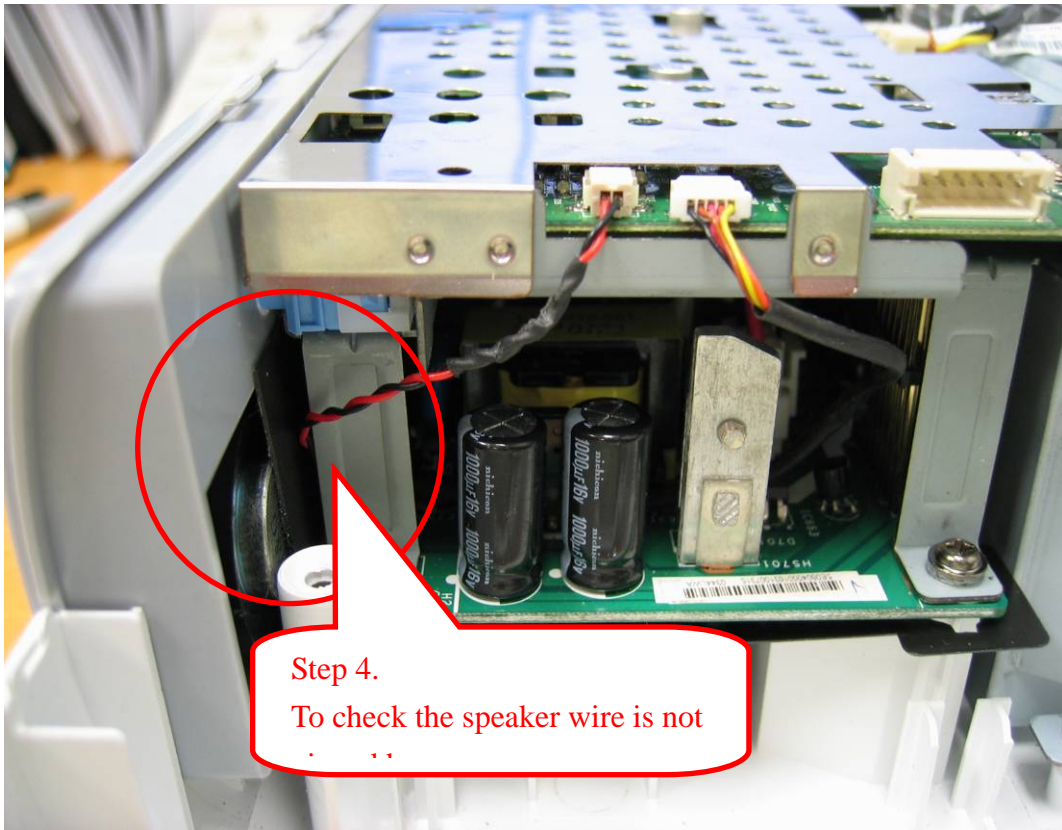

### 3.10. Twin fans assembly and wire alignment.

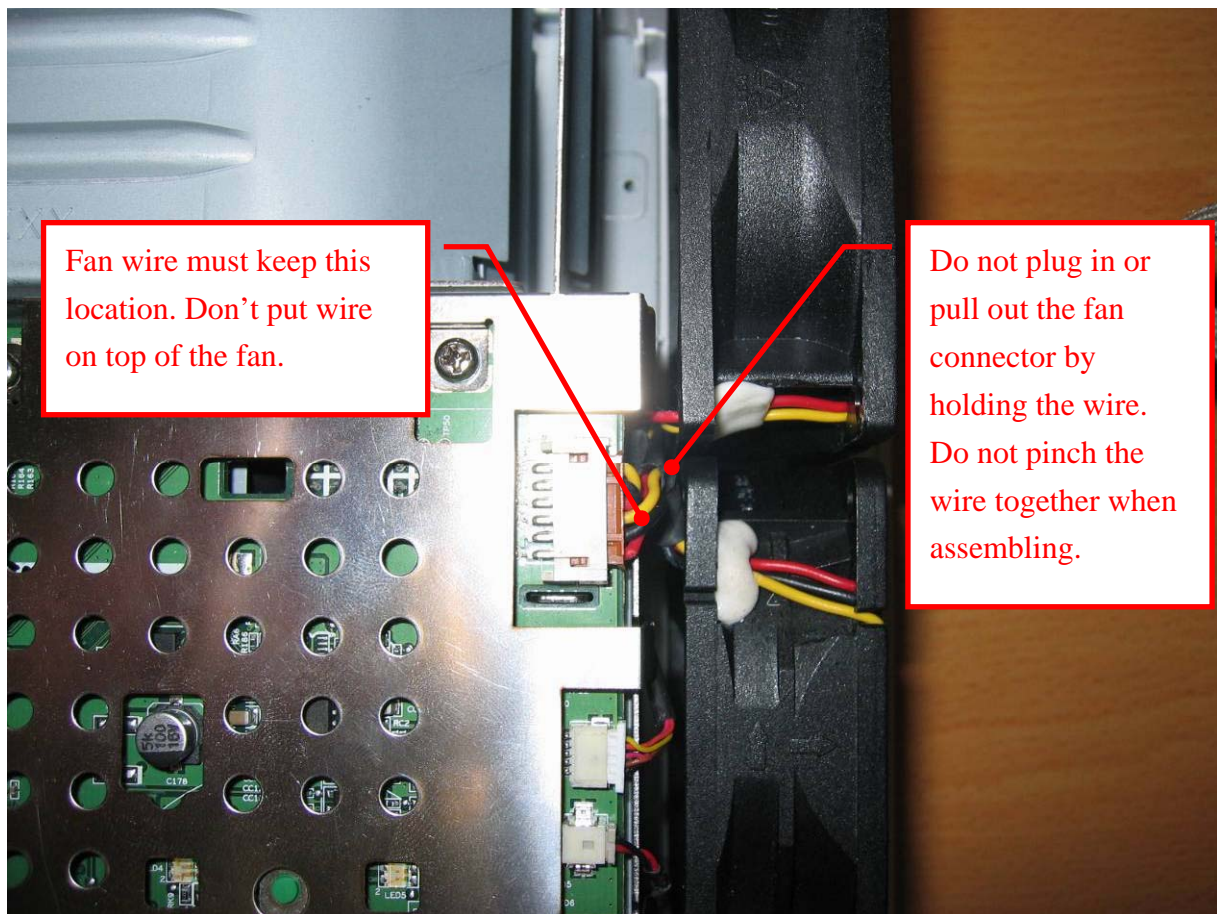
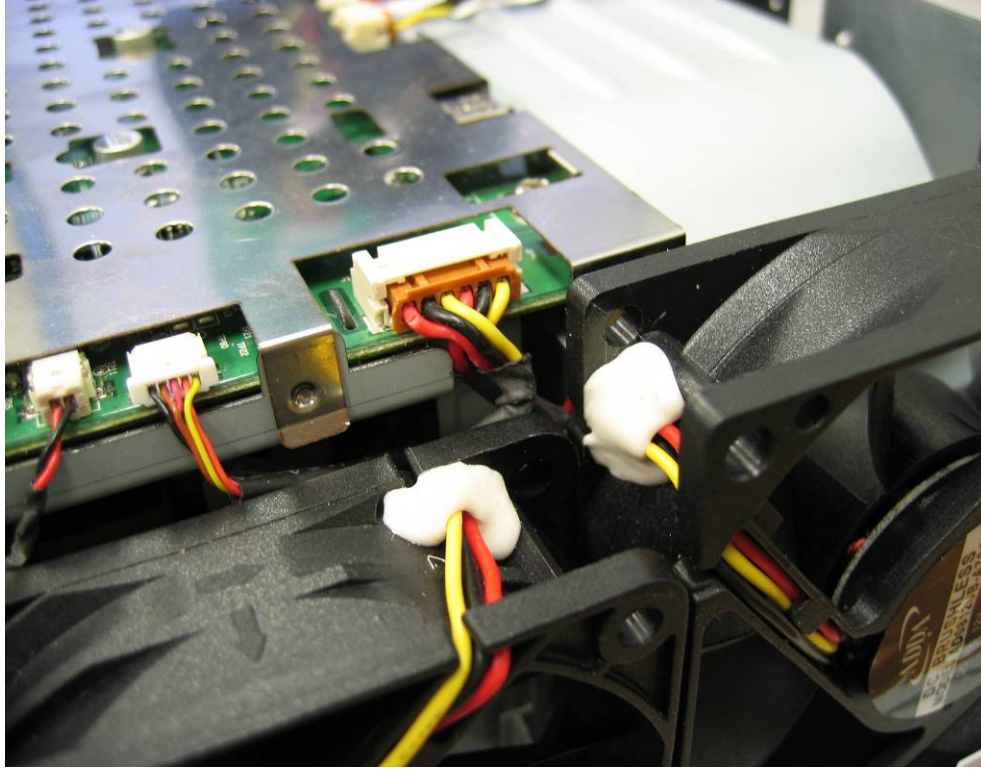

### 3.11. IR board assembly

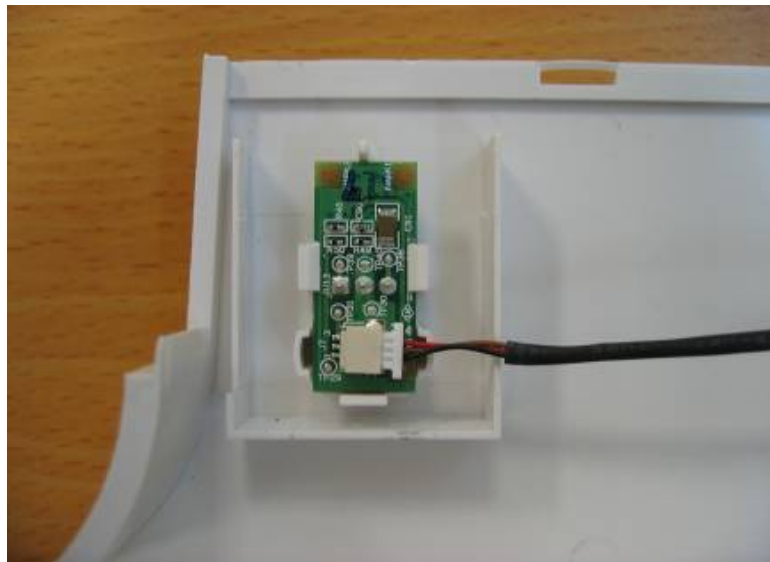
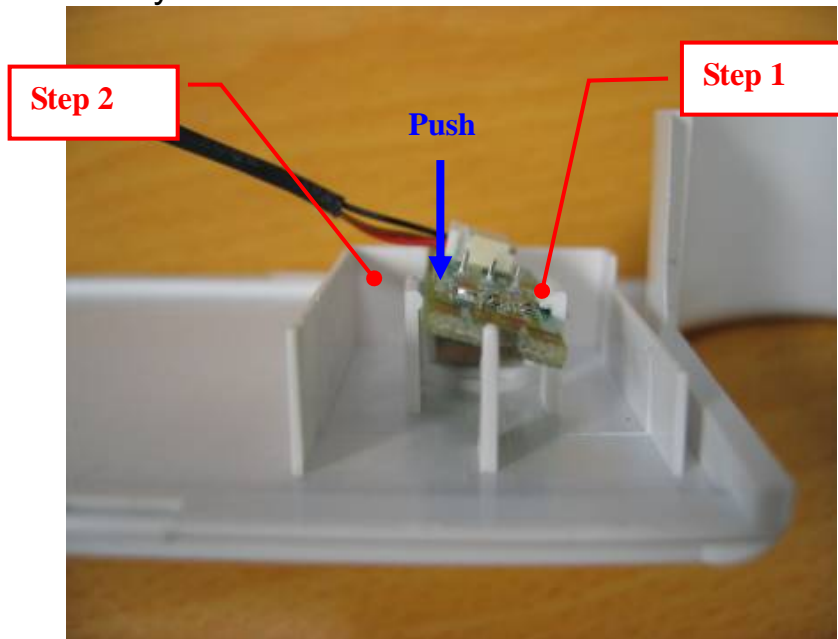



### 3.12. Upper case, inlet cover and outlet cover assembly

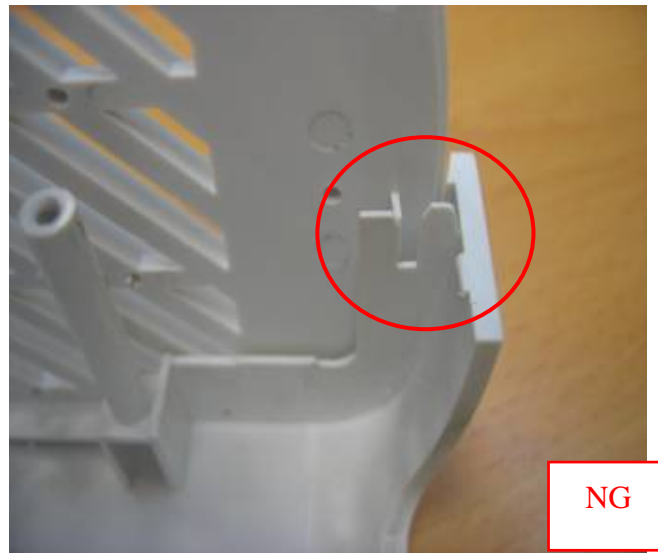
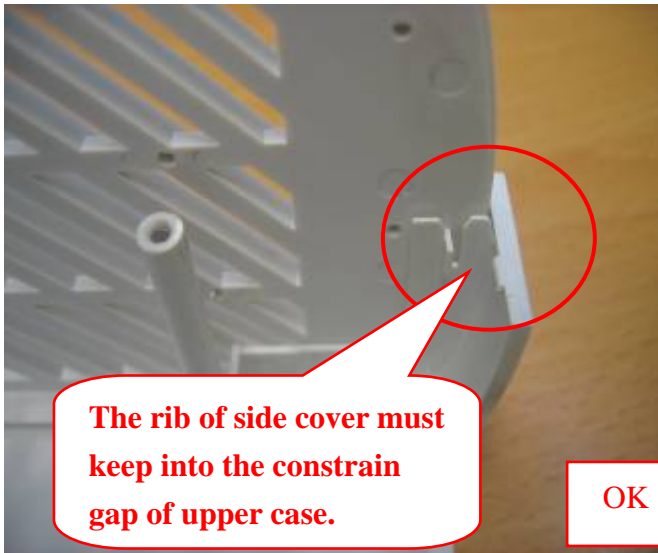
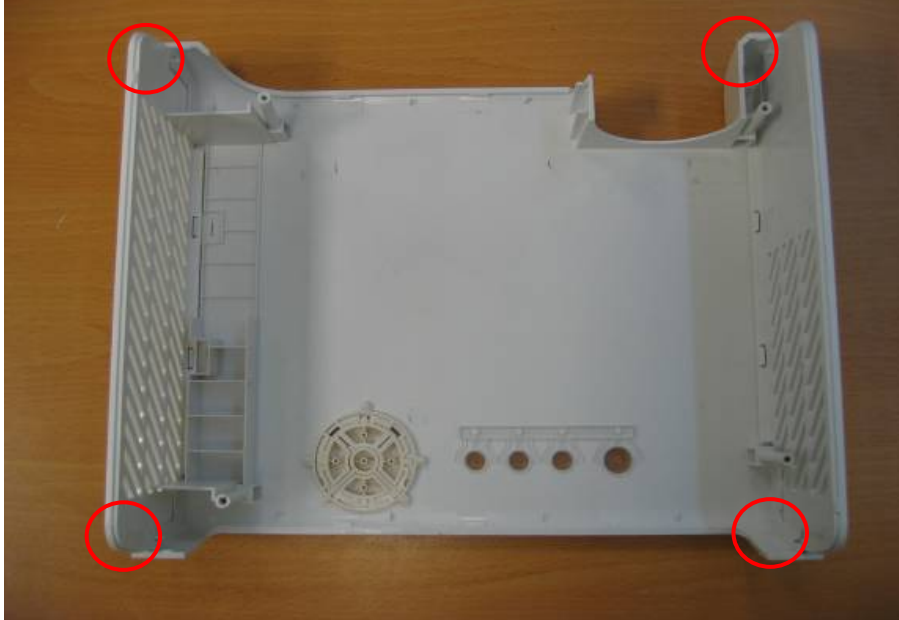



## 4. Power Assembly Concern

a. The wire from power to ballast --

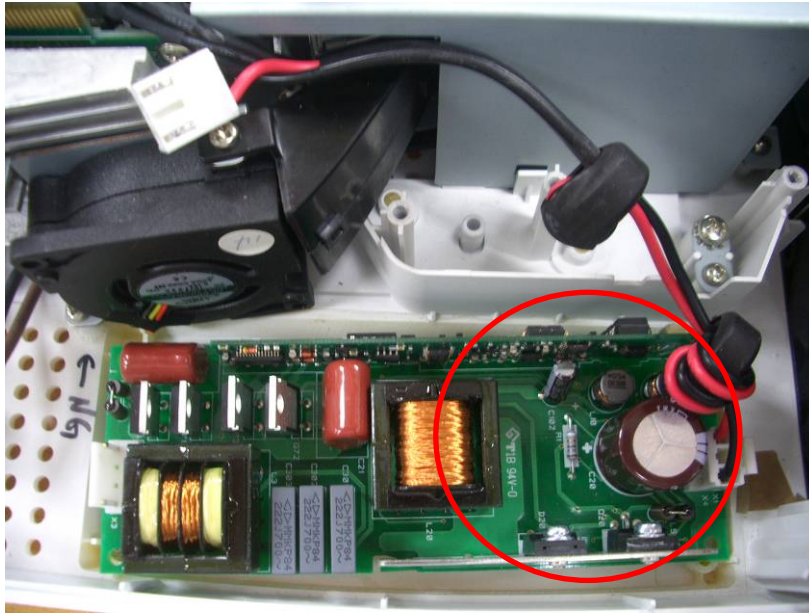
The connector near the core should be connected with the ballast.

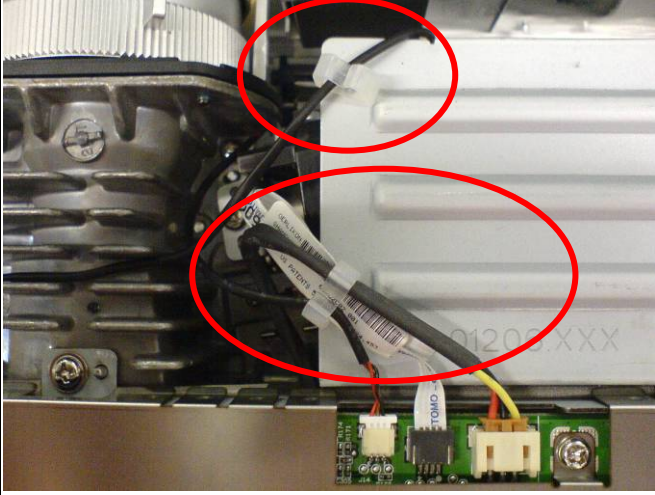
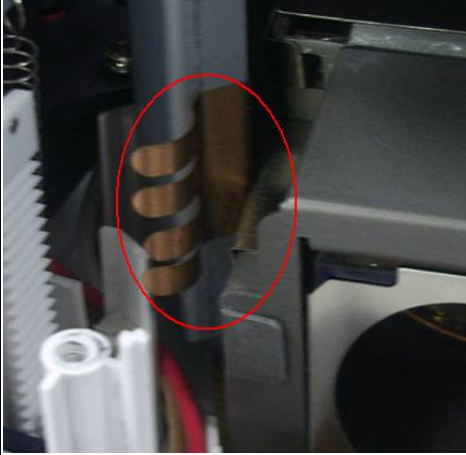

# 5. EMI Assembly Concern

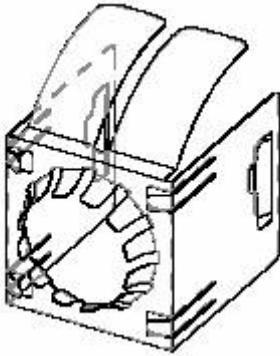
Item	Solution
1.	<p>Fix the cable at the binding core by this way</p> 
2.	<p>Add one spring</p> 
3.	<p>Add one spring</p>  

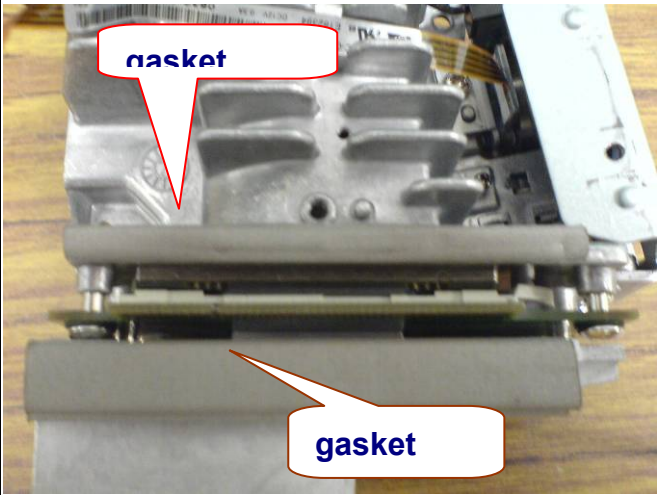
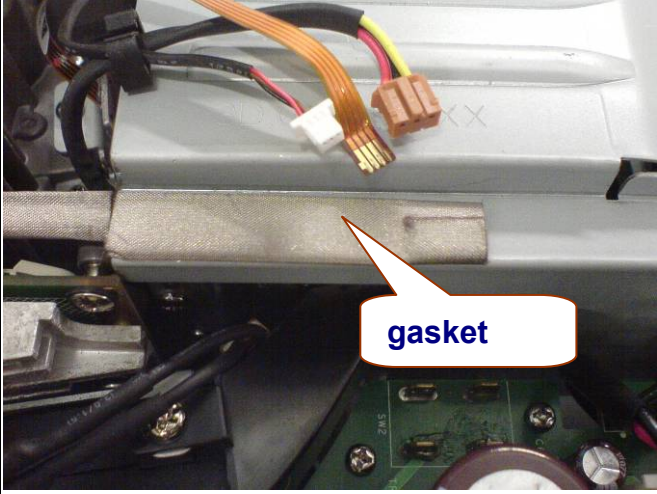
Item	Solution
<p>4. Add two gasket</p>	
<p>5. Add one gasket</p>	



# Disassembly/Assembly

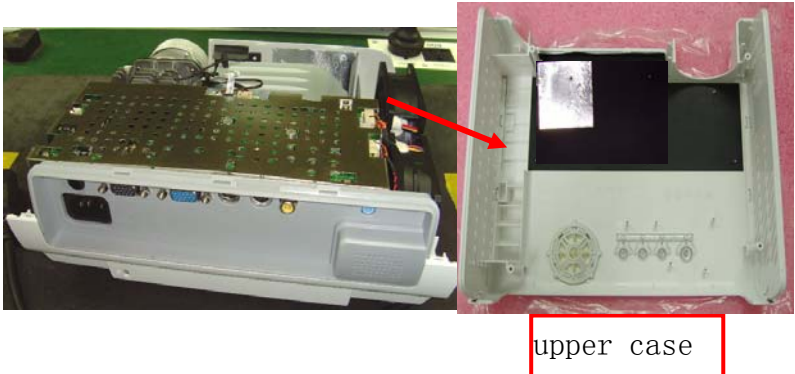
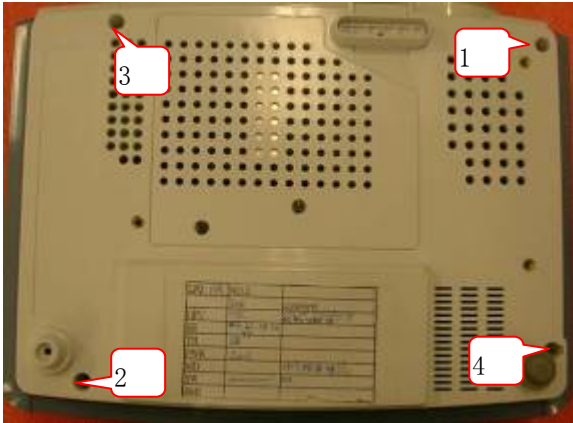
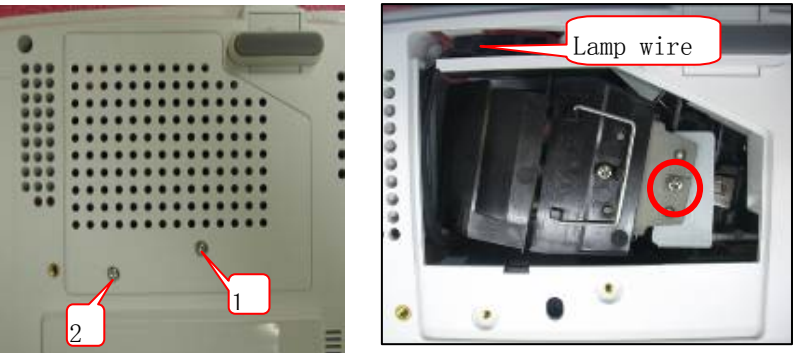
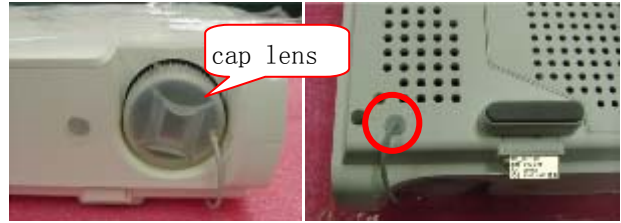

## Disassembly SOP

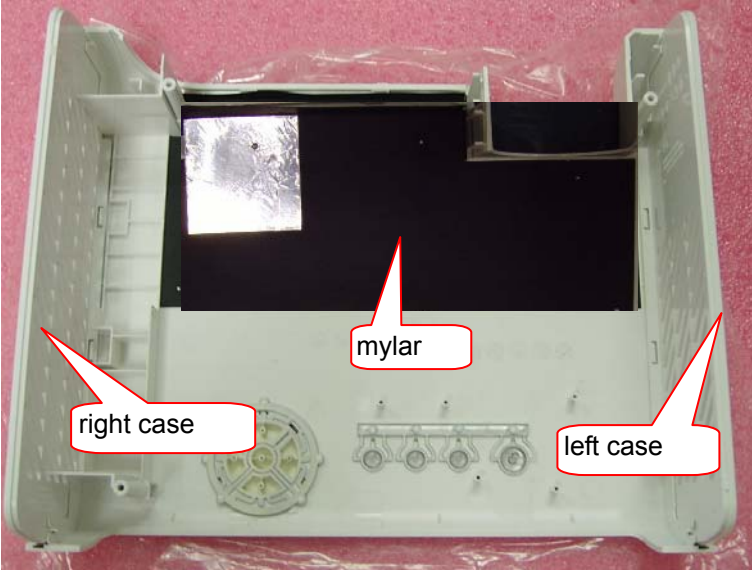
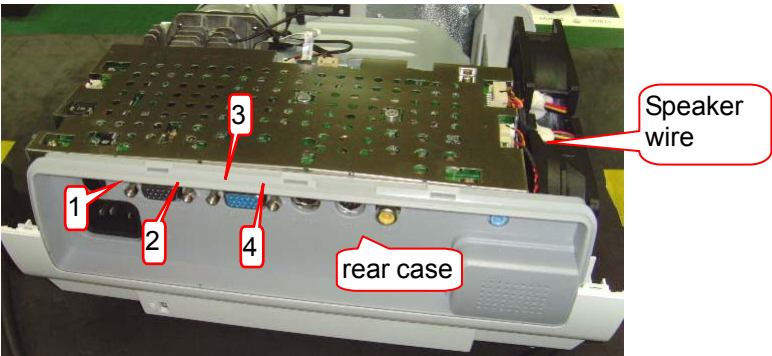
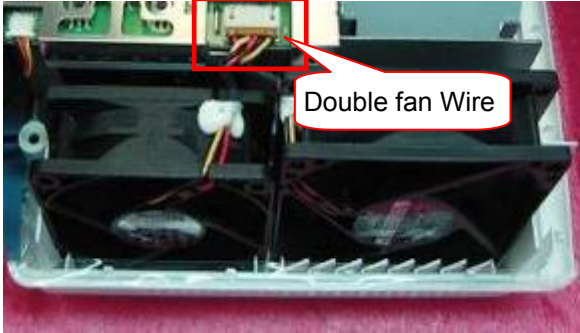
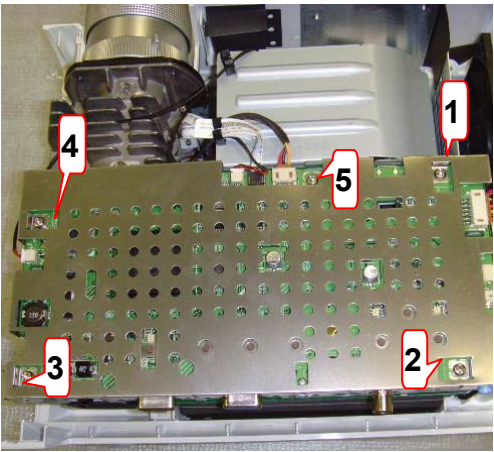
PJ513D Dismantle SOP		
Step	Description	Parts
1	take off the cap lens	cap lens
2	disassembly the screw*2, and take off the lamp door, disassembly the screw*1 and lamp wire, take off the lamp module.	screw*3, lamp door, lamp wire, lamp module
3	disassembly the screw*4	screw*4
4	take off the upper case module	upper case module

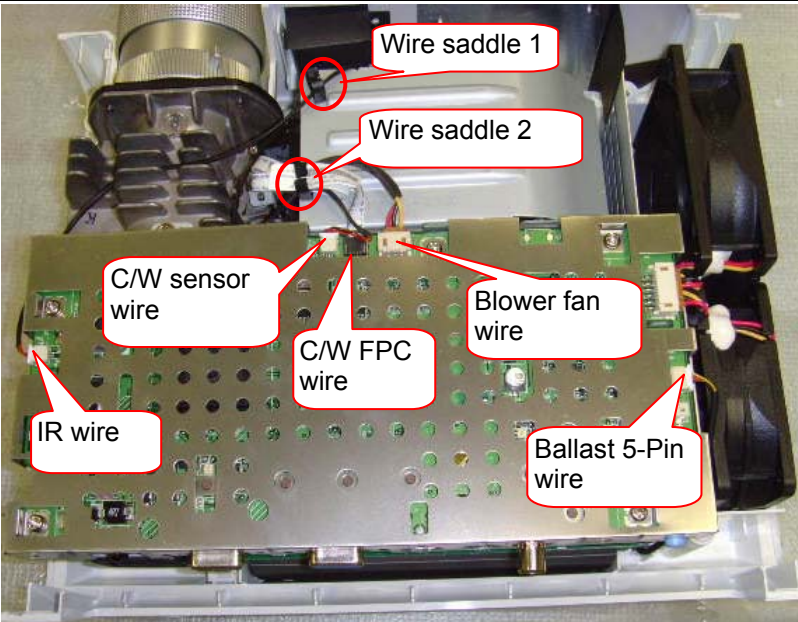

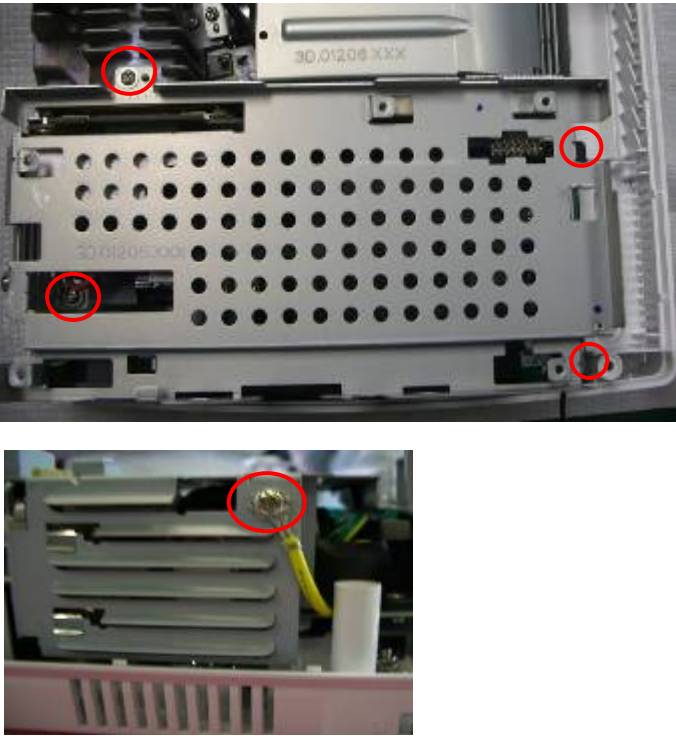

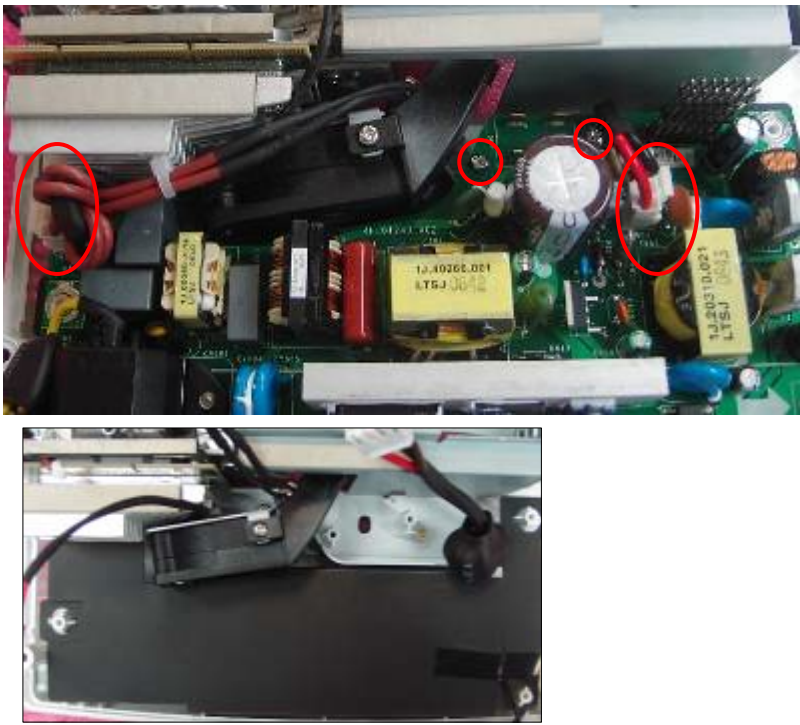
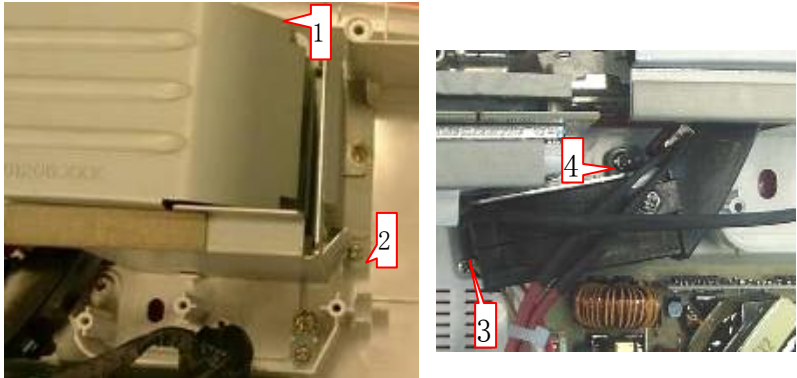
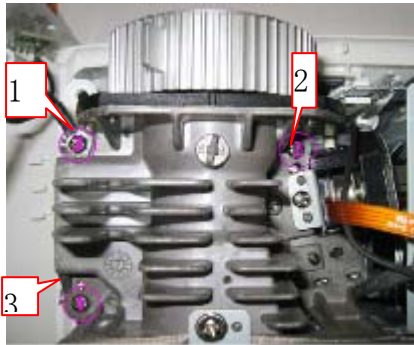

5	take off the upper case mylar, left and right case module from upper case		upper case mylar, left and right case module
6	disassembly the screw*4, take off the Speaker wire and rear case		screw*4, Speaker wire, rear case
7	disassembly the double fan, and take off the double fan wire		double fan, double fan wire
8	disassembly the screw*5, and take off the M/B shielding		screw*5, M/B shielding

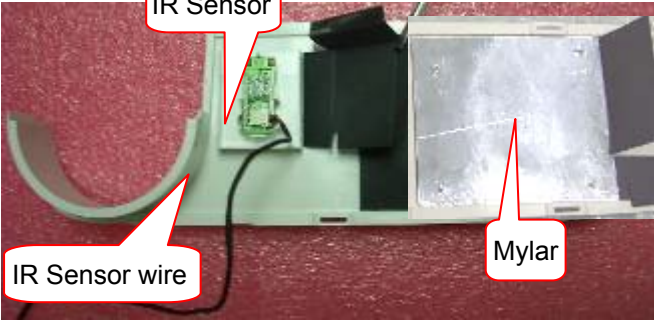
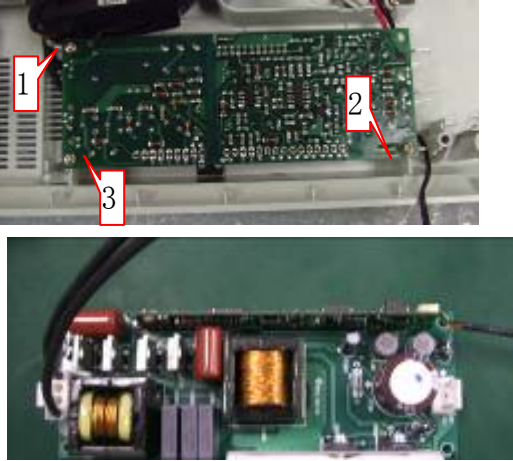
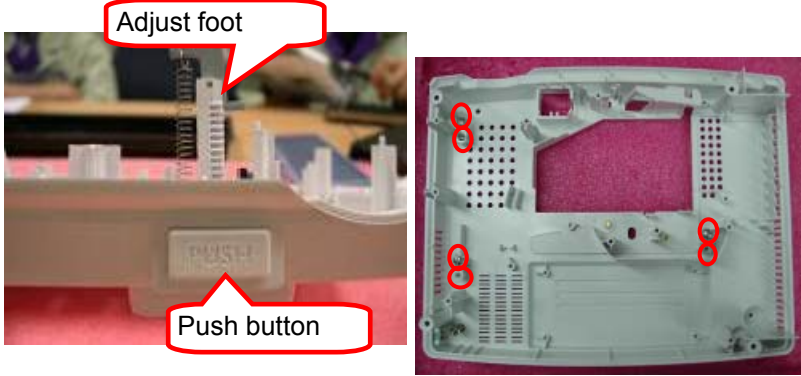

9	<p>take off the C/W FPC wire, blower fan wire, C/W sensor wire, Ballast 5-Pin wire, IR wire, wire saddle*2</p>		<p>C/W FPC wire, blower fan wire, C/W sensor wire, Ballast 5-Pin wire, IR wire, wire saddle*2</p>
10	<p>take off the M/B</p>		<p>M/B</p>
11	<p>disassembly the screw*4, disassembly the grounding screw*1 and take off the Power B/D SHD</p>		<p>screw*5, Power B/D SHD</p>

12	disassembly the wire*2 and screw*2, take off the power BD and ballast Mylar		wire*2 screw*2, power BD, ballast Mylar
13	disassembly the screw*4, take off the lamp box and the blower fan		screw*4, lamp box, blower fan
14	disassembly the screw*3, take off the OPT eng and IR wire.		screw*3, OPT eng, IR wire
15	take the Front case module		Front case module

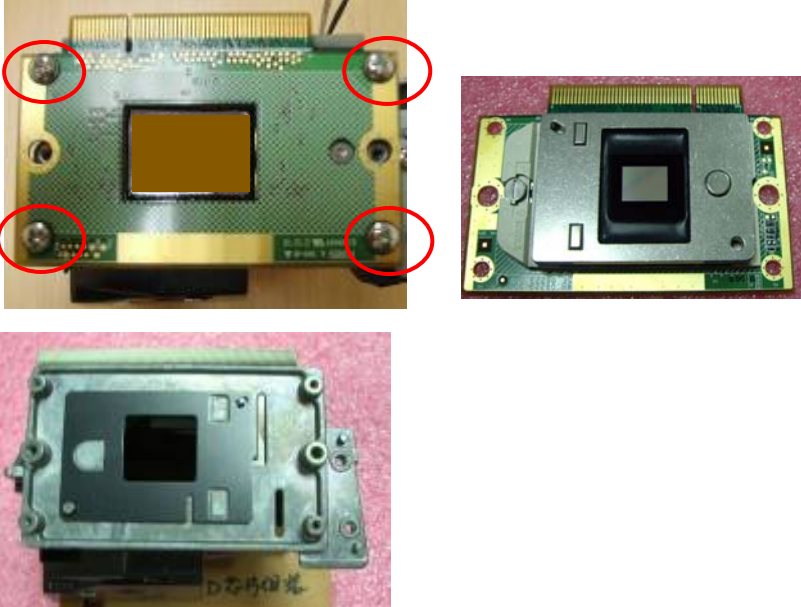
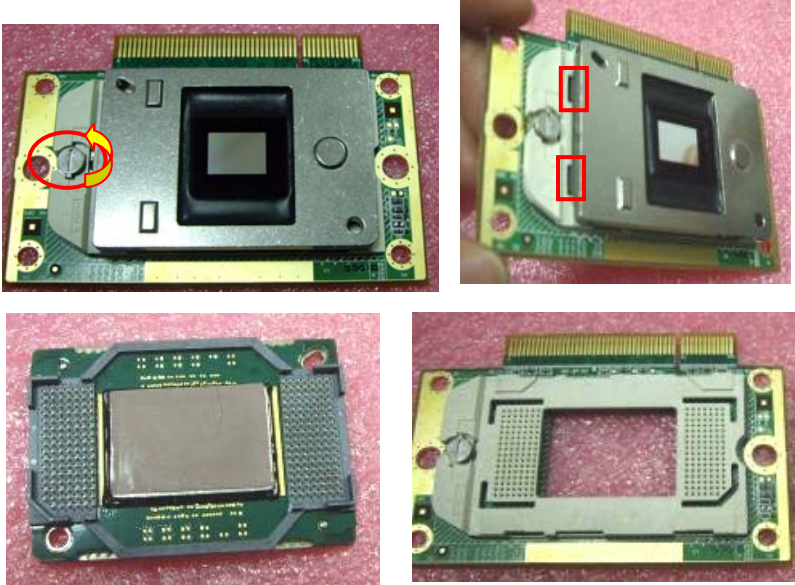

16	take off the Front case mylar, IR Sensor and IR Sensor wire module from Front case		Front case mylar, IR Sensor, IR Sensor wire
17	disassembly the screw*3 and the ballast BD, wire*3		screw*3, ballast BD, wire*3
18	take off the push button and the adjust foot, disassembly the screw*6 and clip*3, the left is lower case		push button, adjust foot, screw*6, clip*3, lower case
19	take off the sponge, disassembly the screw*2 and DMD HSINK		sponge, screw*2, DMD HSINK

20	disassembly the screw*2, take off the CW shielding, disassembly the screw*1 and take off the CW module		screw*3, CW shielding, CW module
21	Remove FOCUS ring		FOCUS ring
22	disassembly the screw*3, take off the PL ass'y		screw*3, PL ass'y

<p>23</p>	<p>disassembly the screw*4, and take off the Chip BD module , take off the Baffle DMD</p>		<p>screw*4, Chip BD, Baffle DMD</p>
<p>24</p>	<p>rotate the screw, take off the DMD IC, take off the Thermal PAD</p>		<p>DMD IC, Thermal PAD</p>
<p>25</p>	<p>disassembly ILL MODULE( screw*2 ),sponge, ASPH lens</p>		<p>ILL MODULE, screw*2, sponge, ASPH lens</p>

26	<p>disassembly the front clip and upper clip, then take off the LP module, adjust screw*2</p>		<p>front clip, upper clip, LP module, adjust screw*2</p>
27	<p>disassembly HSG baffle and screw*1 from HSG</p>		<p>HSG baffle, screw*1</p>

## 6. Troubleshooting Flow Chart





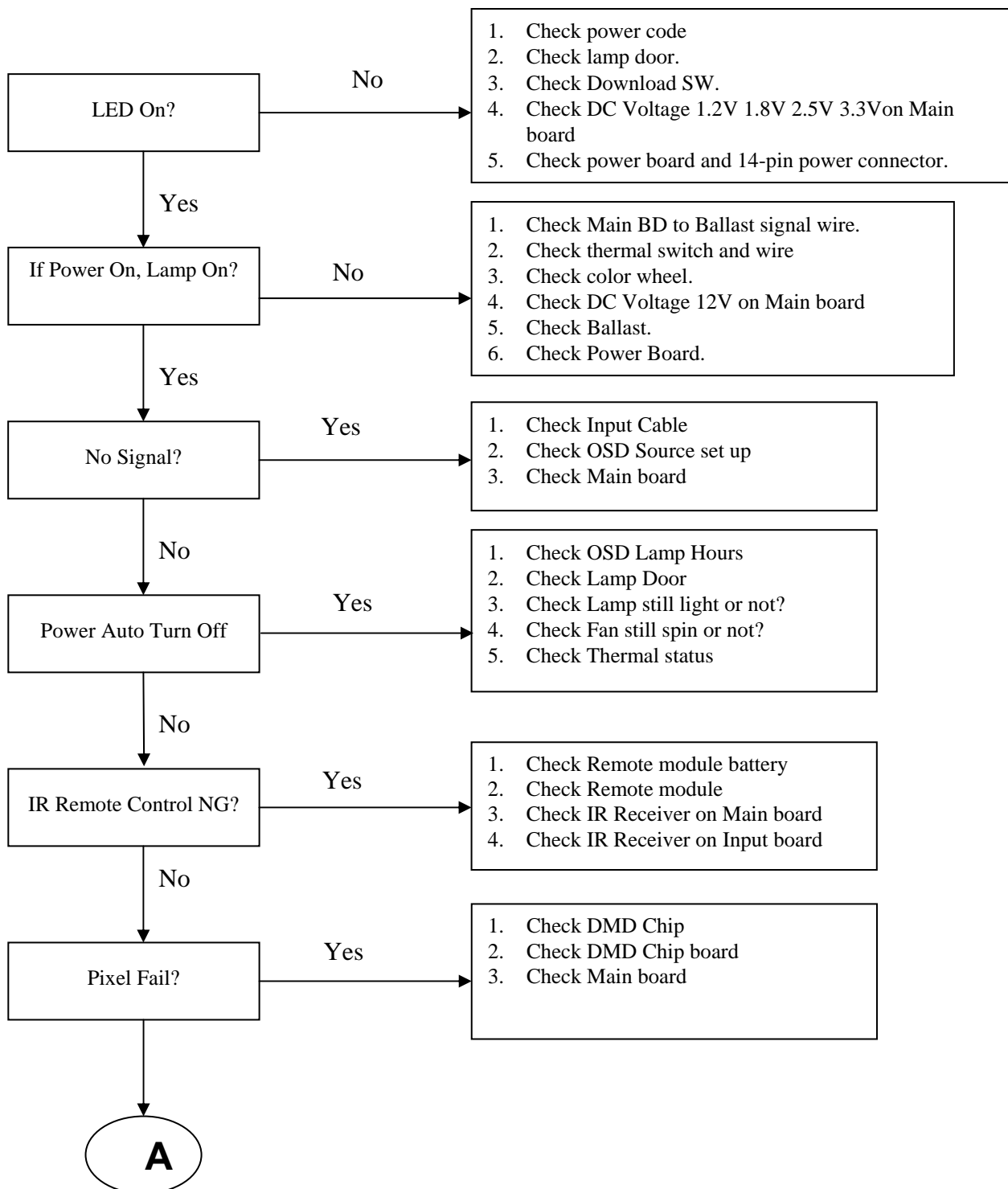

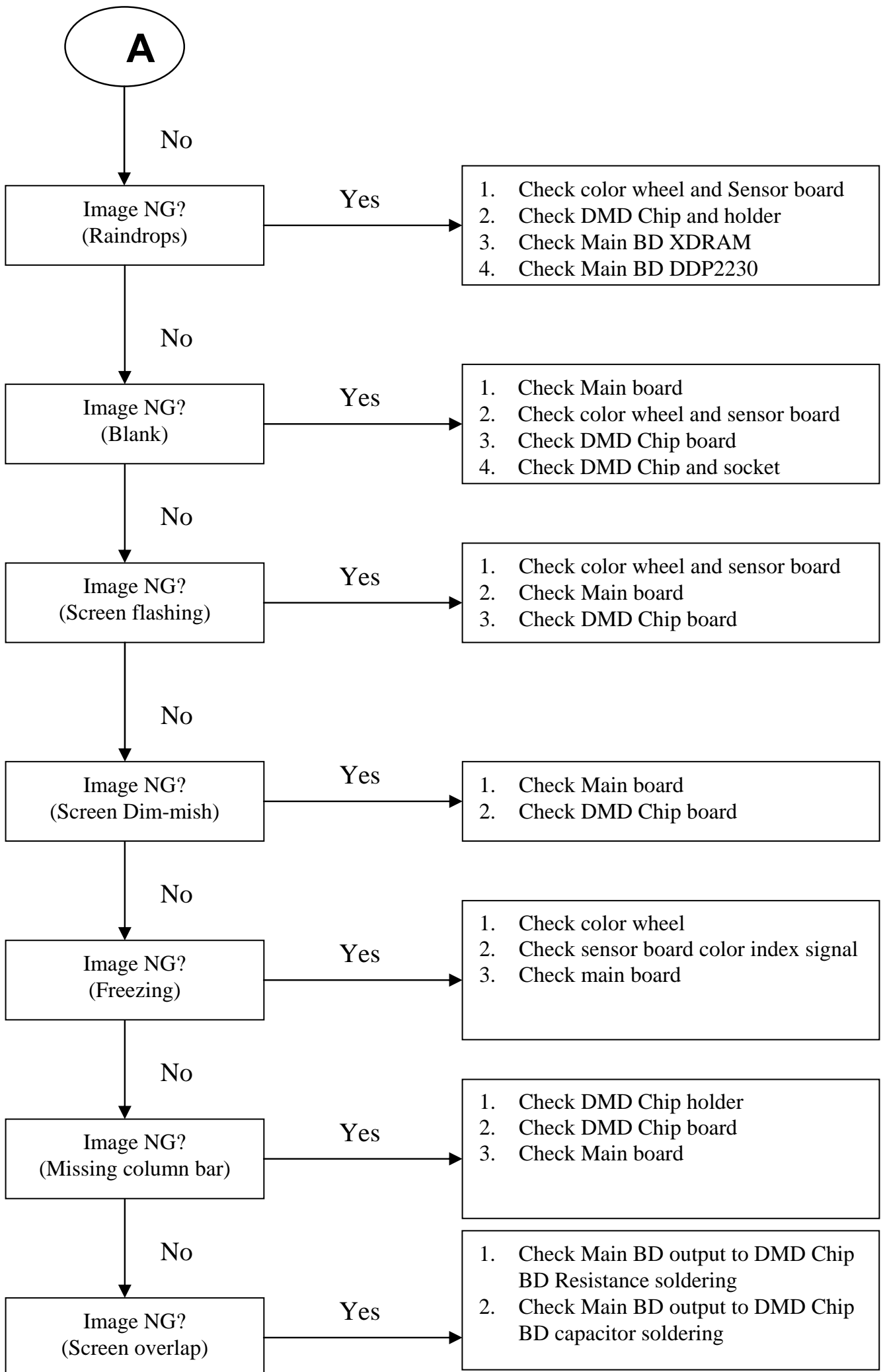













### 1. System Trouble Shooting Flow Chart

System Trouble Shooting Flow Chart





## 2. Error Message

Power	Temp	Lamp	Status	Note
	-	-	Stand-by	
	-	-	Powering up	
	-	-	Normal operation	
	-	-	Normal power-down cooling	
	-	-	First Lamp-Lit error cooling	
Lamp Error Messages				
	-		Second Lamp-Lit error	
-	-		Lamp error in normal operation	
Thermal Error Messages				
-		-	Fan 1 error (the actual fan speed is $\pm 20\%$ outside the desired speed.)	Lamp Fan
-			Fan 2 error (the actual fan speed is $\pm 20\%$ outside the desired speed.)	Ballast Fan
-			Fan 3 error (the actual fan speed is $\pm 20\%$ outside the desired speed.)	Blower Fan
			Thermal Sensor 1 open error (the remote diode has an open-circuit condition.)	DMD sensor
			Thermal Sensor 2 open error (the remote diode has an open-circuit condition.)	
			Thermal Sensor 1 short error (the remote diode has an short-circuit condition.)	DMD sensor
			Thermal Sensor 2 short error (the remote diode has an short-circuit condition.)	
			Temperature 1 error (over limited temperature)	DMD sensor
			Temperature 2 error (over limited temperature)	
-			Fan IC #1 I2C Connection error	GMT 793

### 3. Power Trouble Shooting Guide

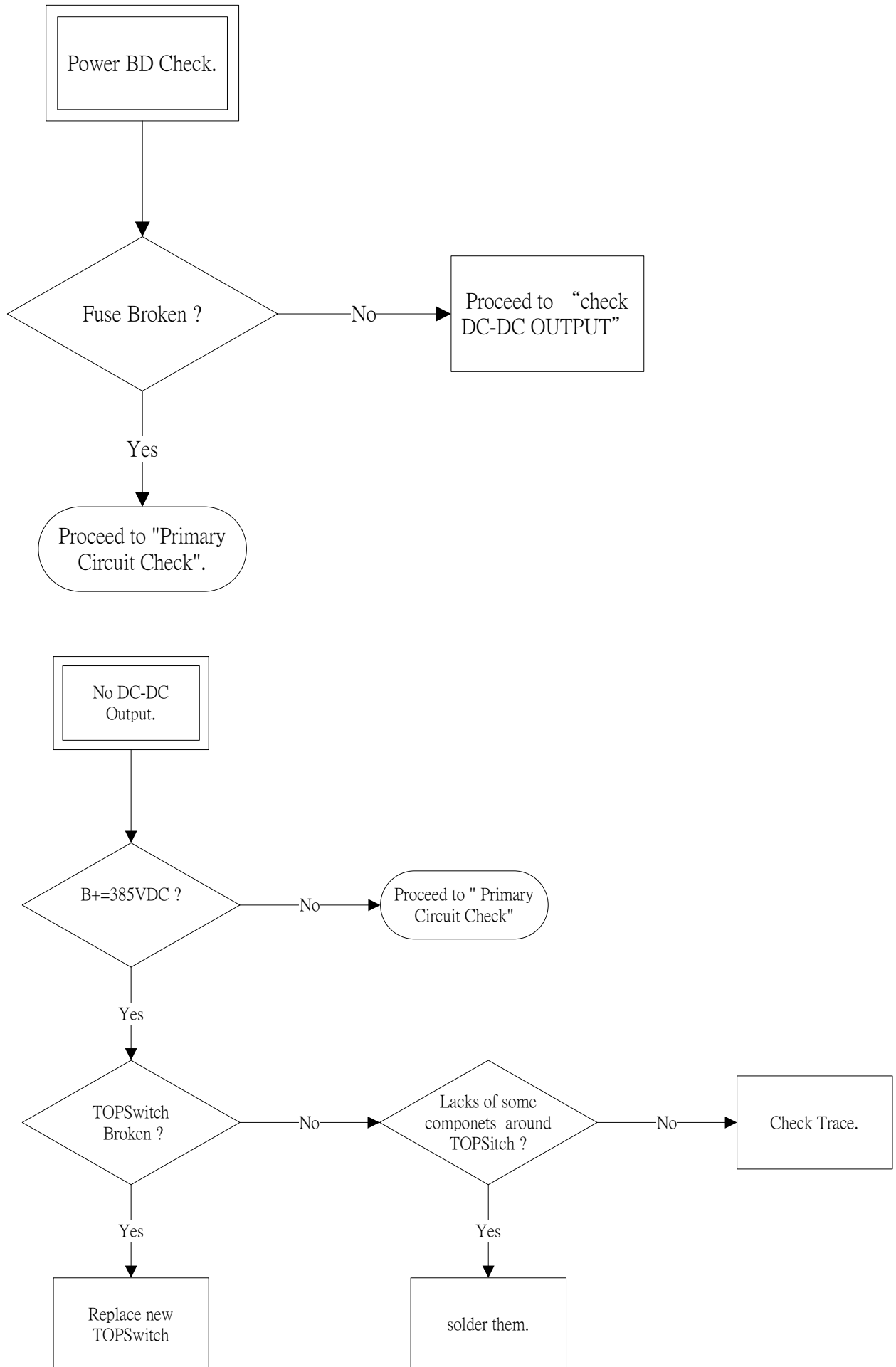



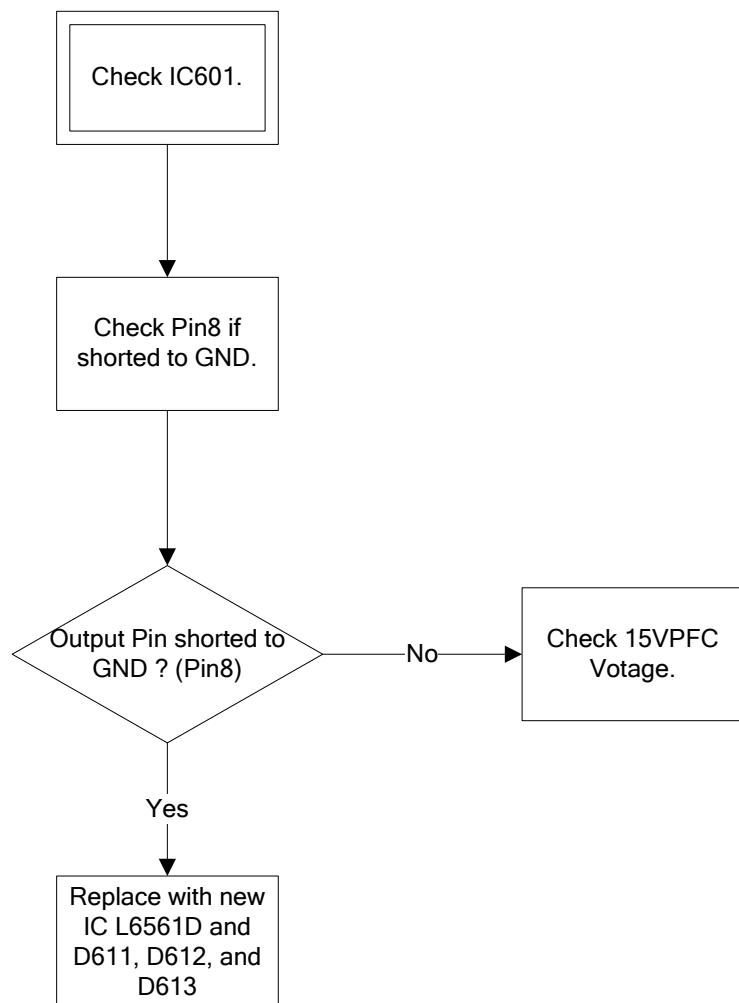
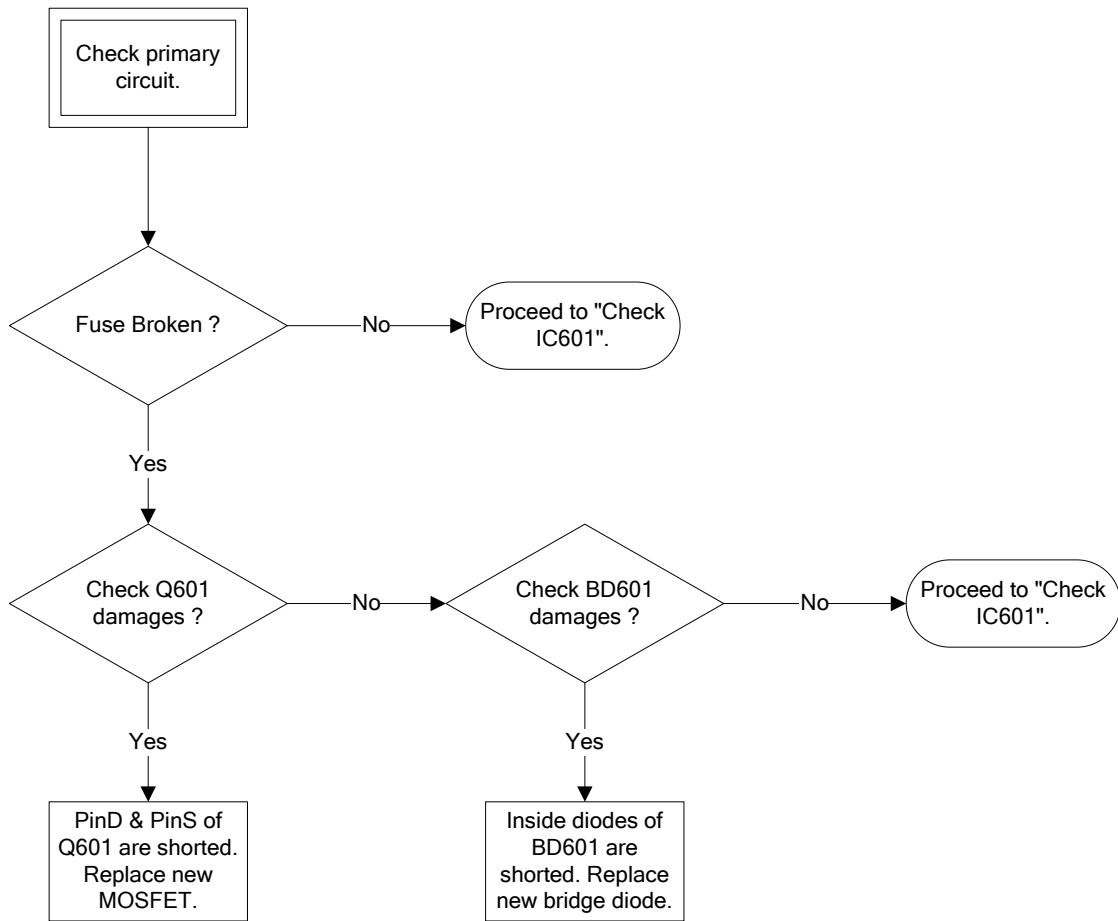

## 4. Optical & Optical Engine Trouble Shooting Guide

### 4-1 Optical Trouble Shooting Guide

No.	Item	Trouble Shooting Guide
1	Brightness	1. Change lamp
2	Uniformity	1. Change lamp
3	FOFO Contrast	1. Check ADC calibration 2. Check user's menu brightness & contrast are default 3. Clean DMD 4. Clean PL 5. Check ILL stop assy
4	ANSI Contrast	1. Clean PL 2. Clean DMD 3. Change PL
5	Color	1. Check color wheel delay 2. Check CW 50% point. Replace CW if necessary
6	Color Uniformity	1. Change lamp
7	Blue Edge	1. Refer to Item#2-1 (attached below) 2. Change CM 3. Change SUB HSG
8	Blue/Purple Border	1. Refer to Item#2-1(attached below) 2. Change CM 3. Change SUB HSG
9	Focus	1. Change Projection Lens 2. Check PL datum and DMD parallel
10	Dust	Clean DMD
11	Horizontal/Vertical Strips	1. Check connector between chipBD and MainBD 2. Re-install DMD with chipBD 3. Check if any pin of C-Spring is missing, damaged or dirty 4. Change new ChipBD/C-Spring 5. Change new DMD
12	Pixel Fail	Change new DMD

## 4-2 Engine Assembly Trouble Shooting Guide

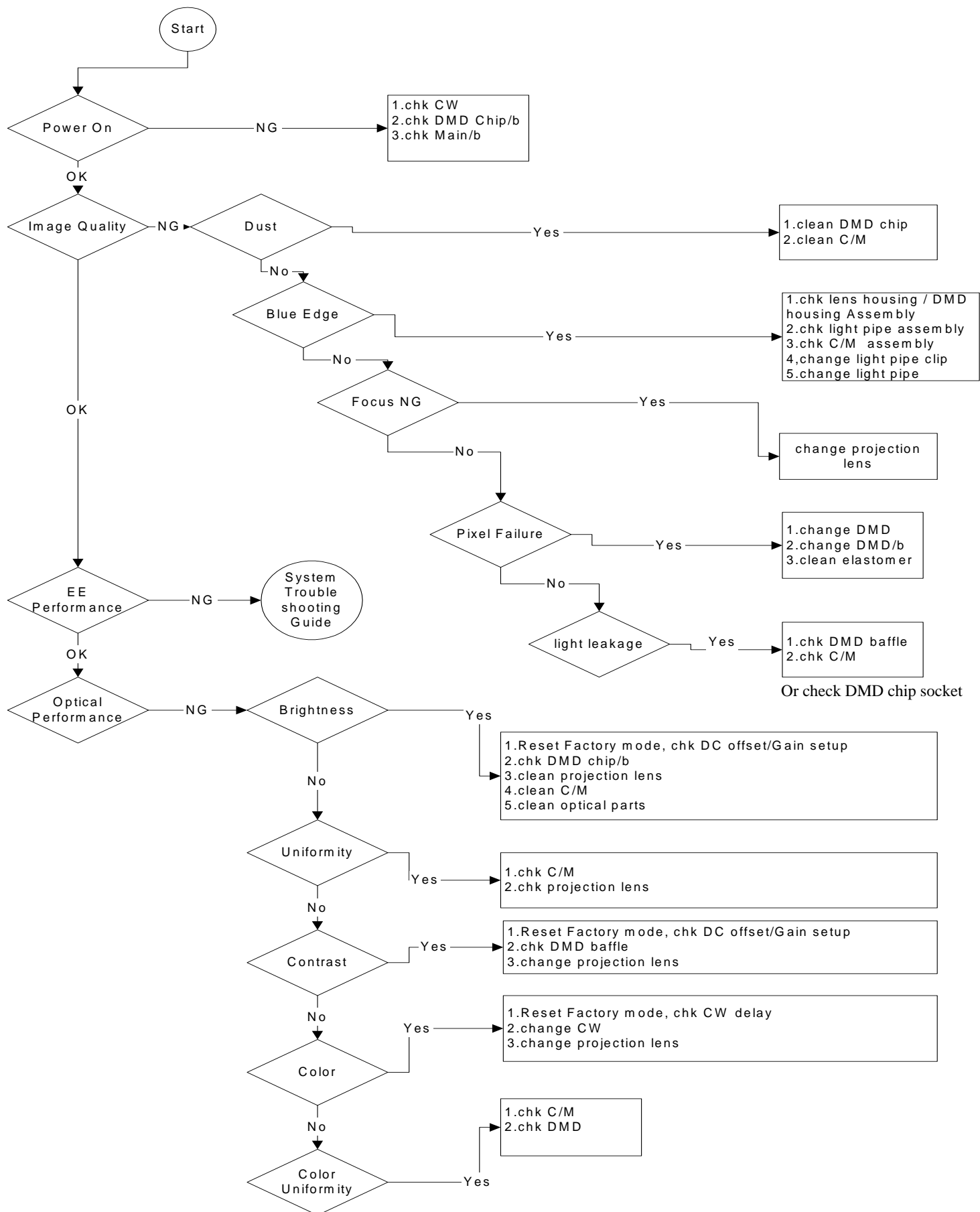

#### 4-3 “Blue Edge” Trouble Shooting:

##### I. Re-adjust “Overfill” first.

For Overfill Re-adjustment:

- i. Those 2 Adjustment Screws must be released for around 2 mm first.
- ii. Alignment Sequence:
  - a. To adjust “Horizontal Adjustment Screw” firstly, then “Vertical Adjustment Screw”.
  - b. Refer to Figure 1-1..

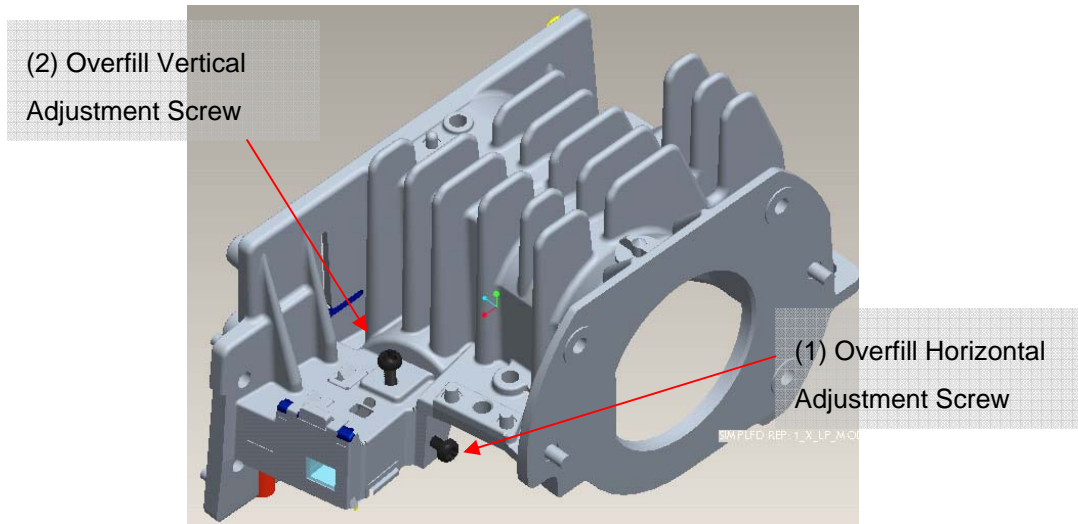

Fig. 1-1

##### II. Re-assemble LP module—include LP, LP Baffle, LP clip.

## 7. Block Diagram

### Hardware Architecture

The Projector consists of the Source board, Main board, Keypad board, Fan board, EMI board, PFC board, Ballast board, Door interlock switch, Color wheel index sensor board, and the Thermal break sensor board. Please see Figure 1.

Source Board consists of audio phone jack, video RCA jack, S-video mini-DIN head, and USB head. Main Board consists of RGB A/D conversion, Video decoder, DLP ASIC, Flash and RAM, Motor driver, DMD Reset driver DAD2000, and IR receiver. Keypad Board consists of 8 keypads and 3 twice-color LEDs. Fan Board consists of DC/DC converter, Thermal Break circuit, Blower Fan driver circuit, Rear Fan driver circuit, and the temperature sensing circuit. Power supply circuit consists of AC line EMI filter, Power Factor Correction circuit. Ballast Board consists of Lamp synchronization circuit, Lamp lit feedback circuit, and Lamp power control circuit.

## Hardware Architecture

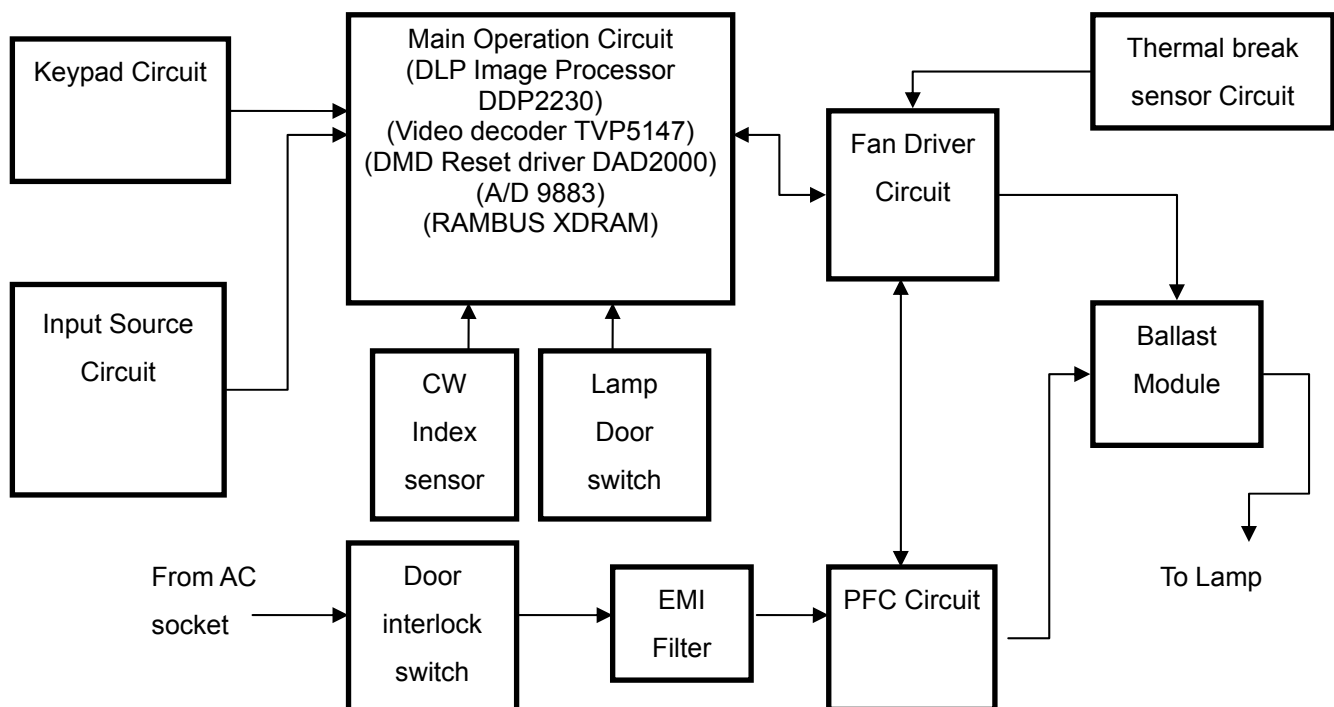

# 8. Schematic Diagrams

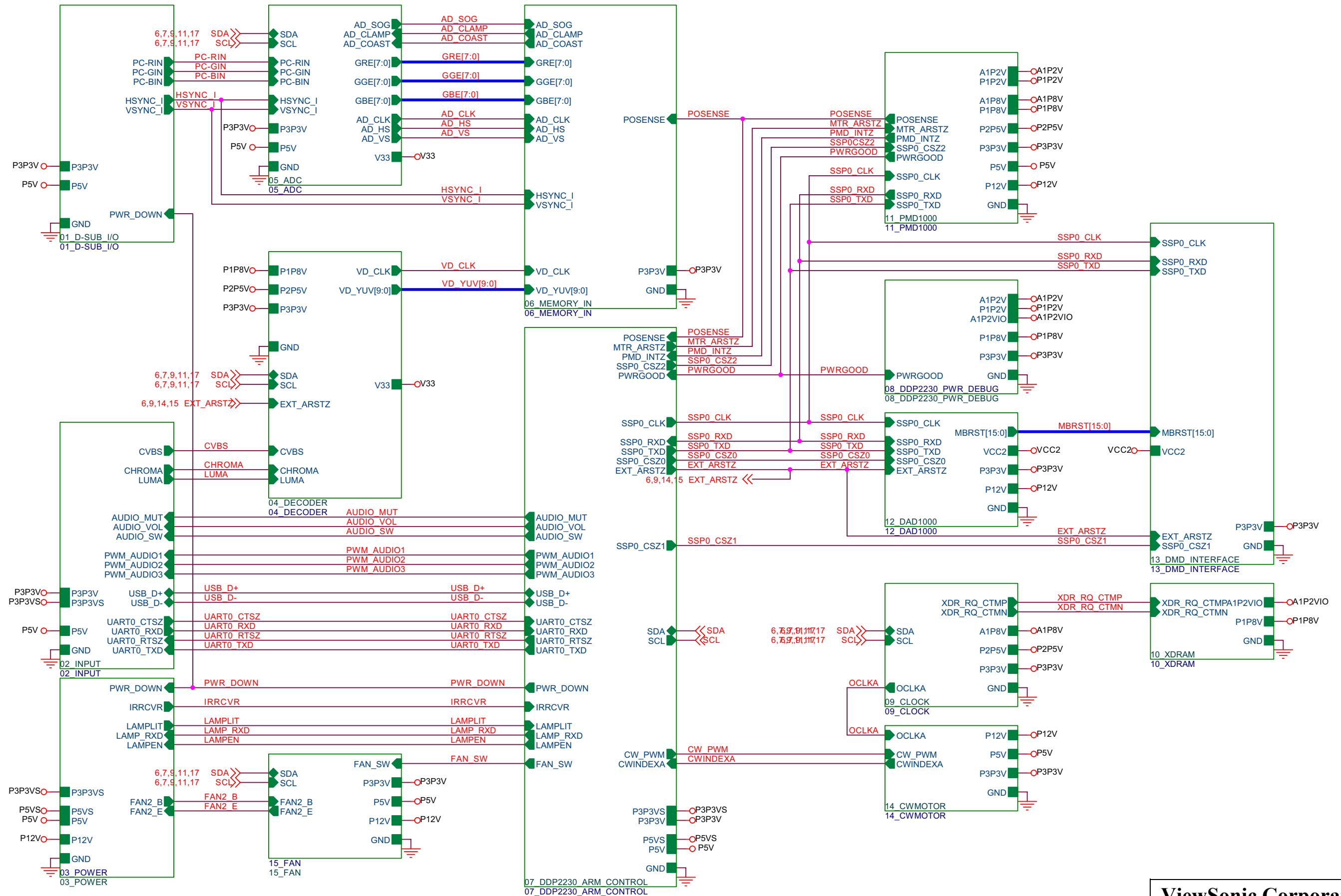

<b>ViewSonic Corporation</b>	
Model	
Title	<b>MAIN BOARD</b>
Date	Rev:

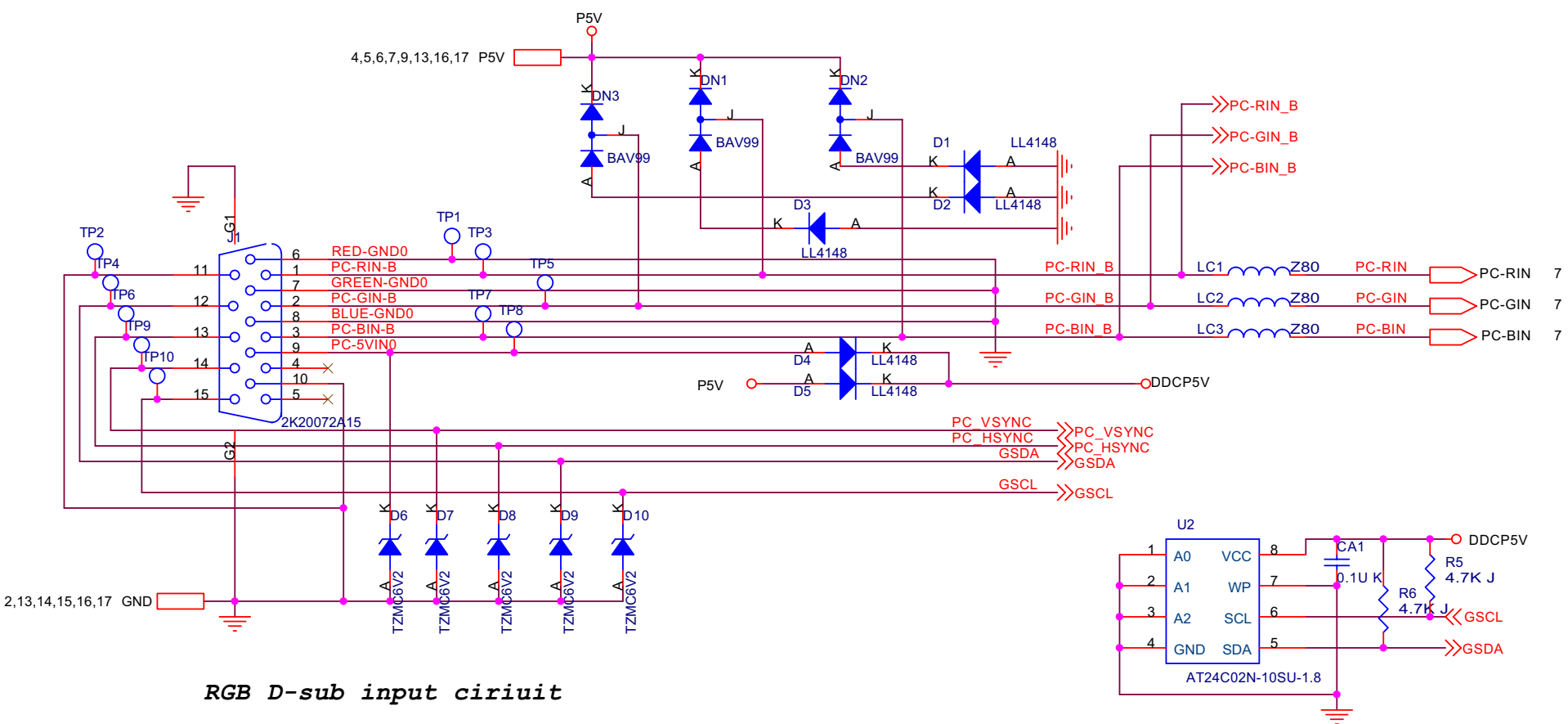

RGB D-sub input cirituit

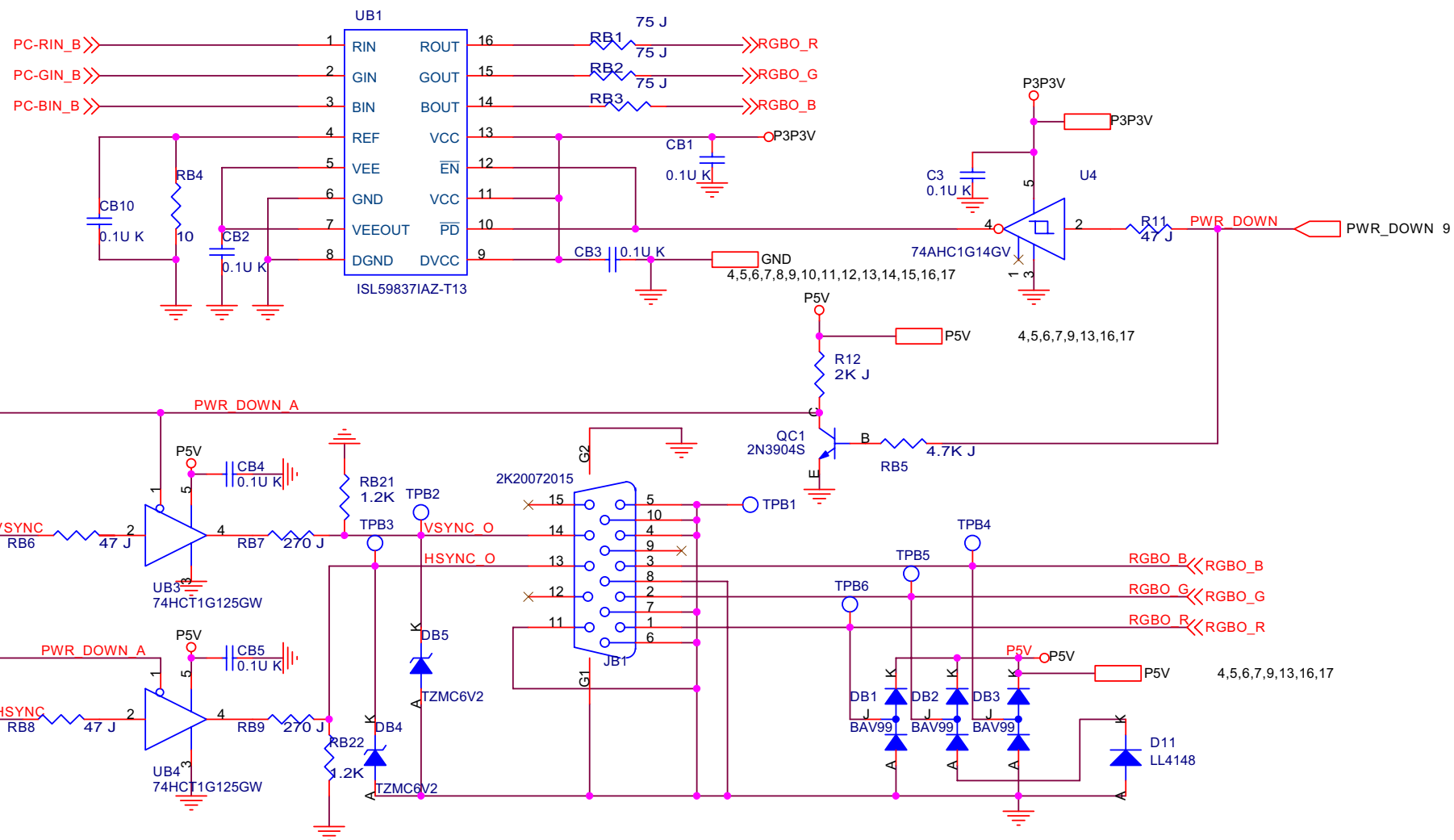
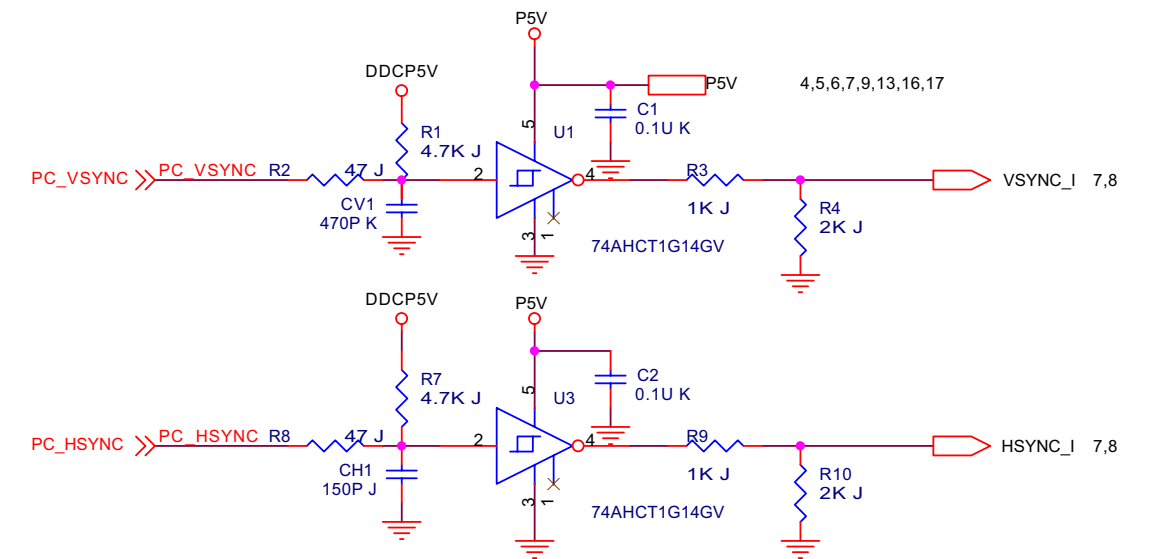

RGB D-sub output cirituit

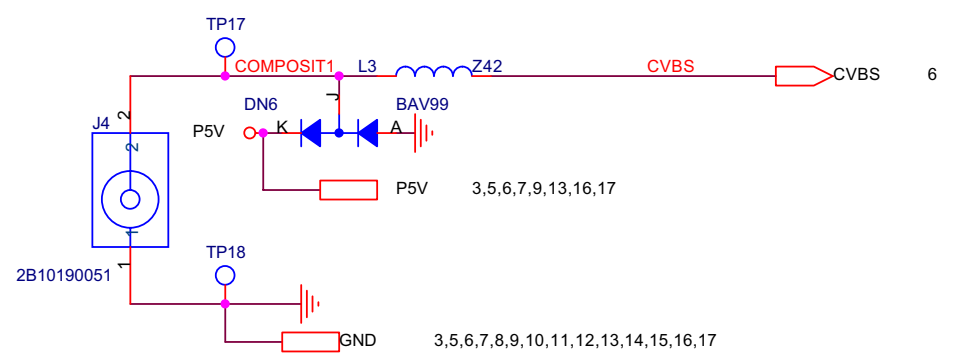
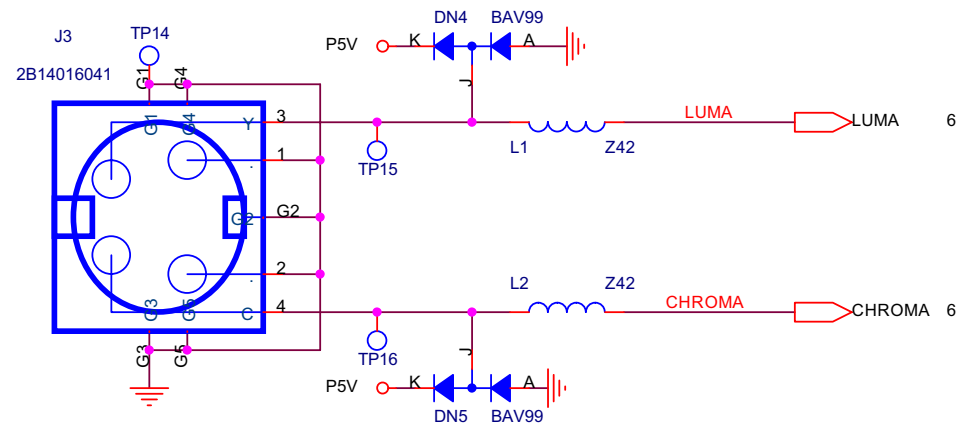

**Video input**

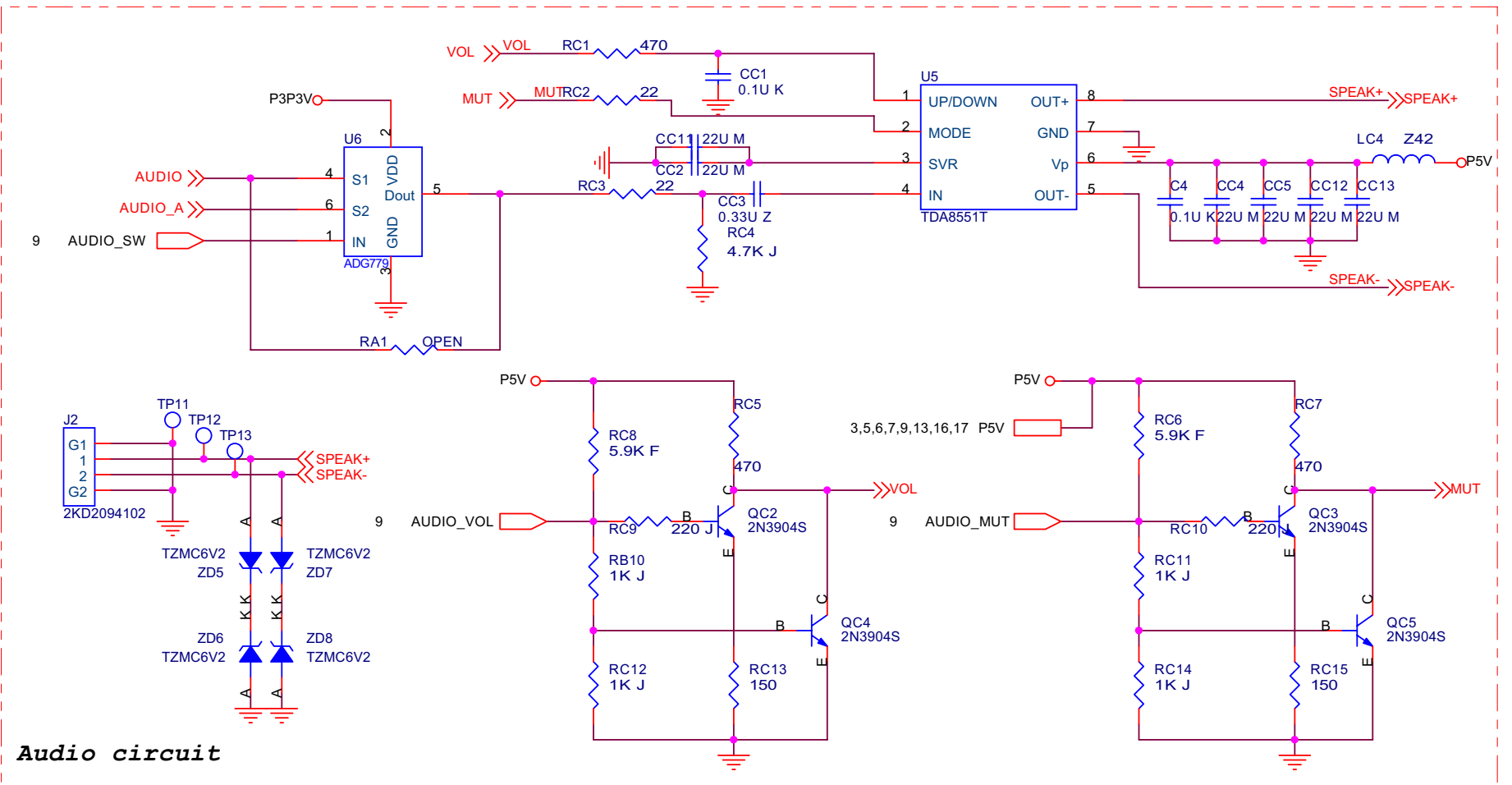

**Audio circuit**

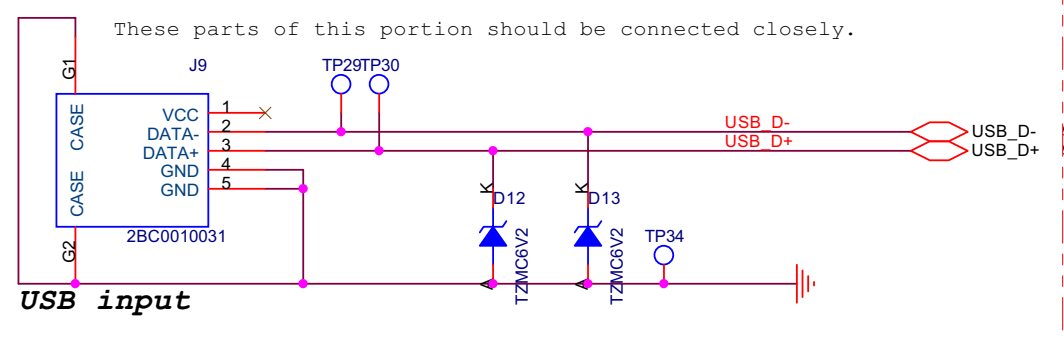

**USB input**

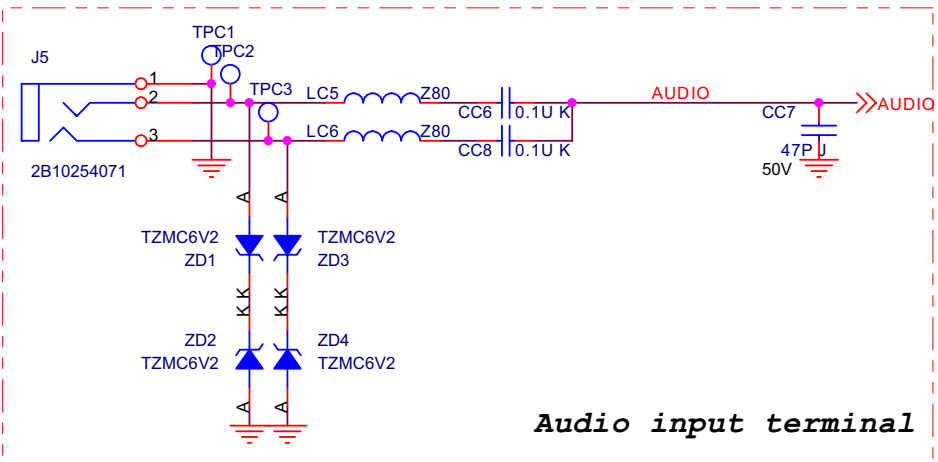

**Audio input terminal**

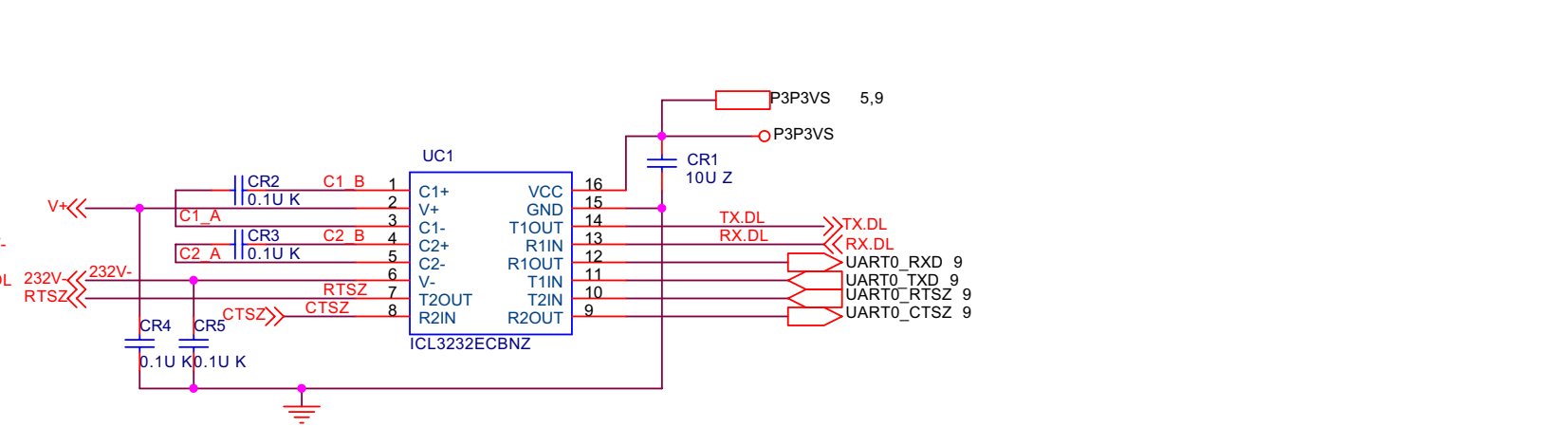
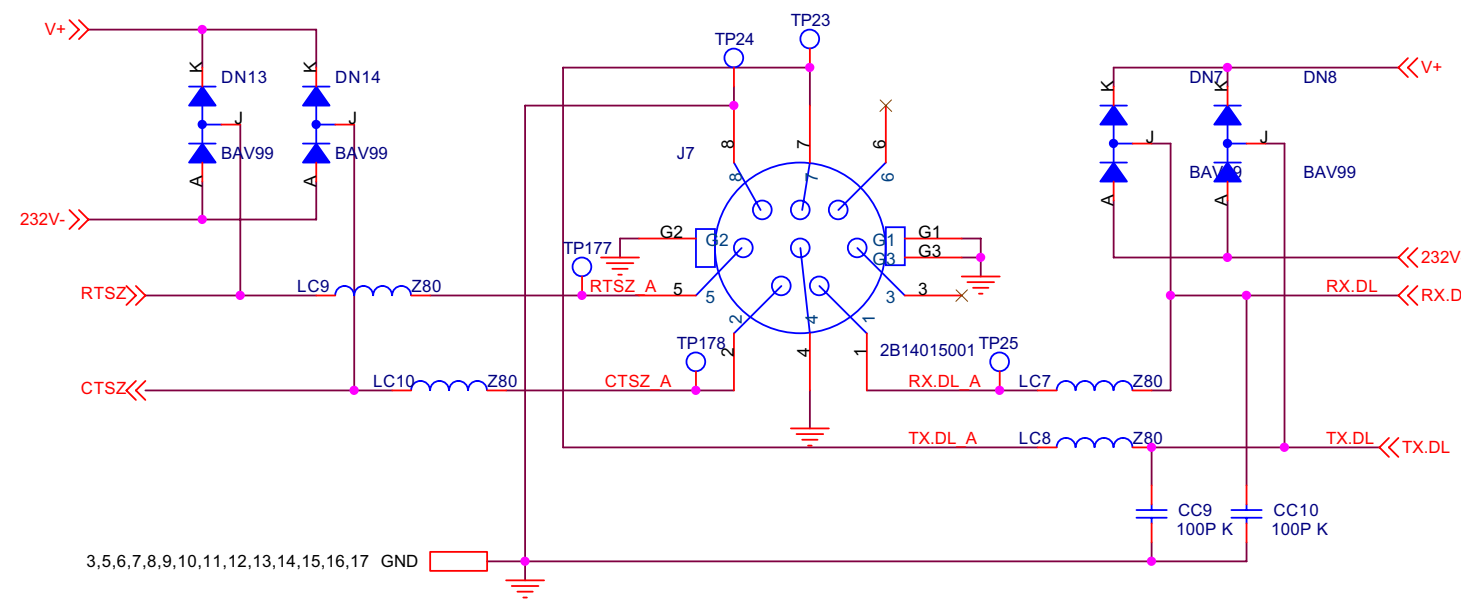
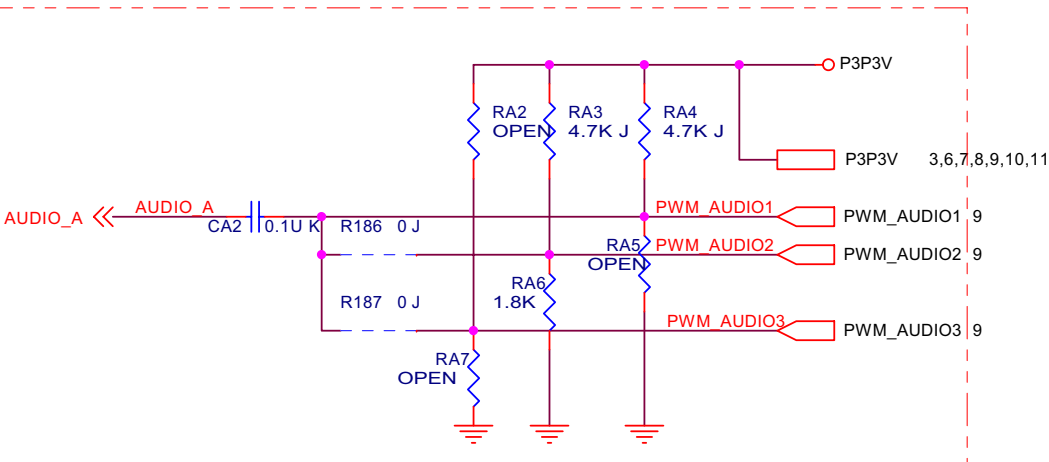

**RS232 circuit**



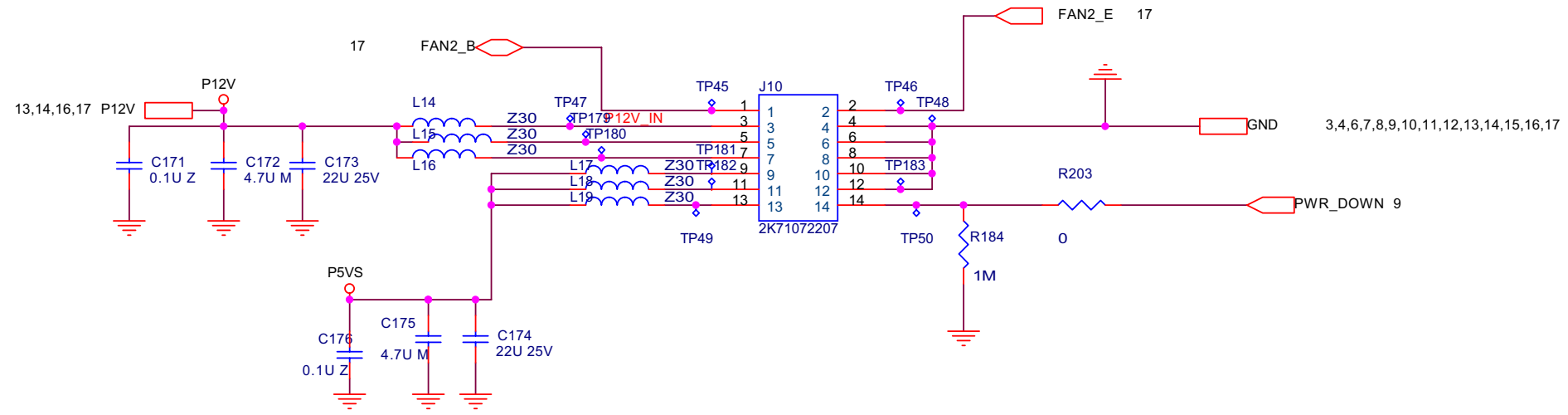

**POWER FROM DC/DC BOARD**

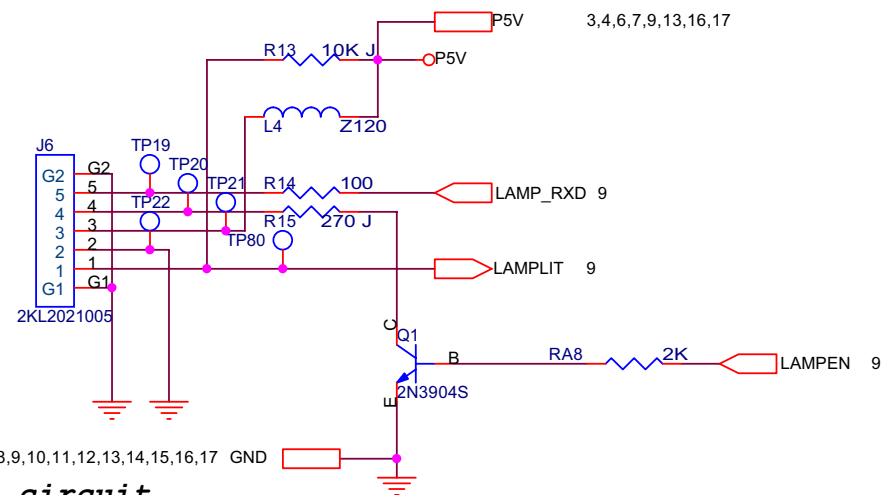

**Lamp circuit**

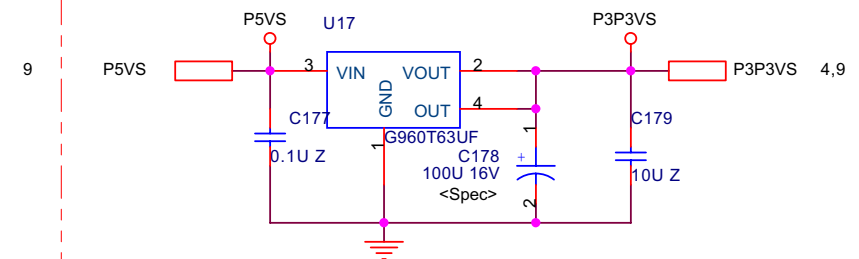

**3.3V POWER**

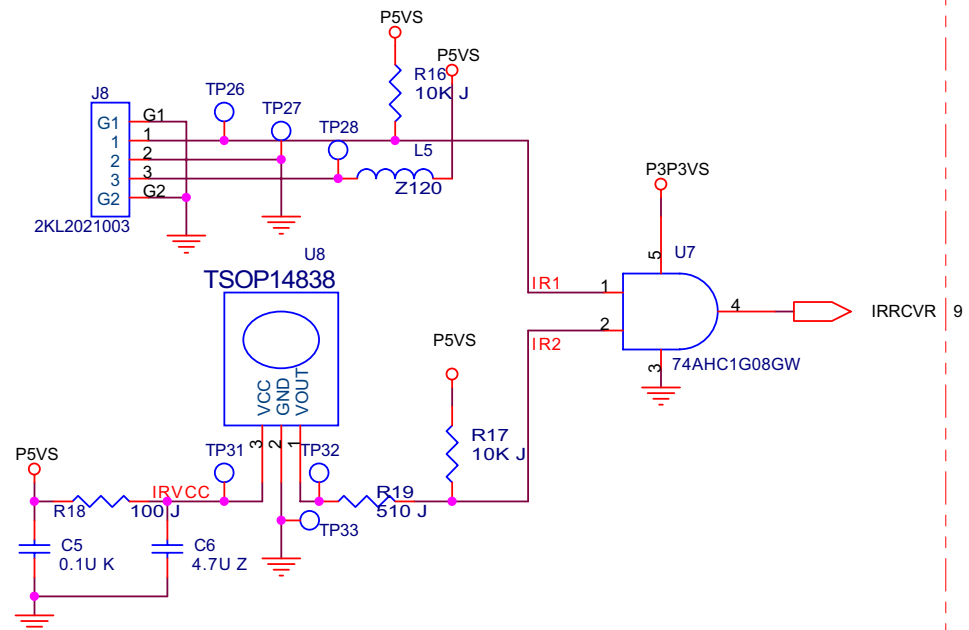

**IR circuit**

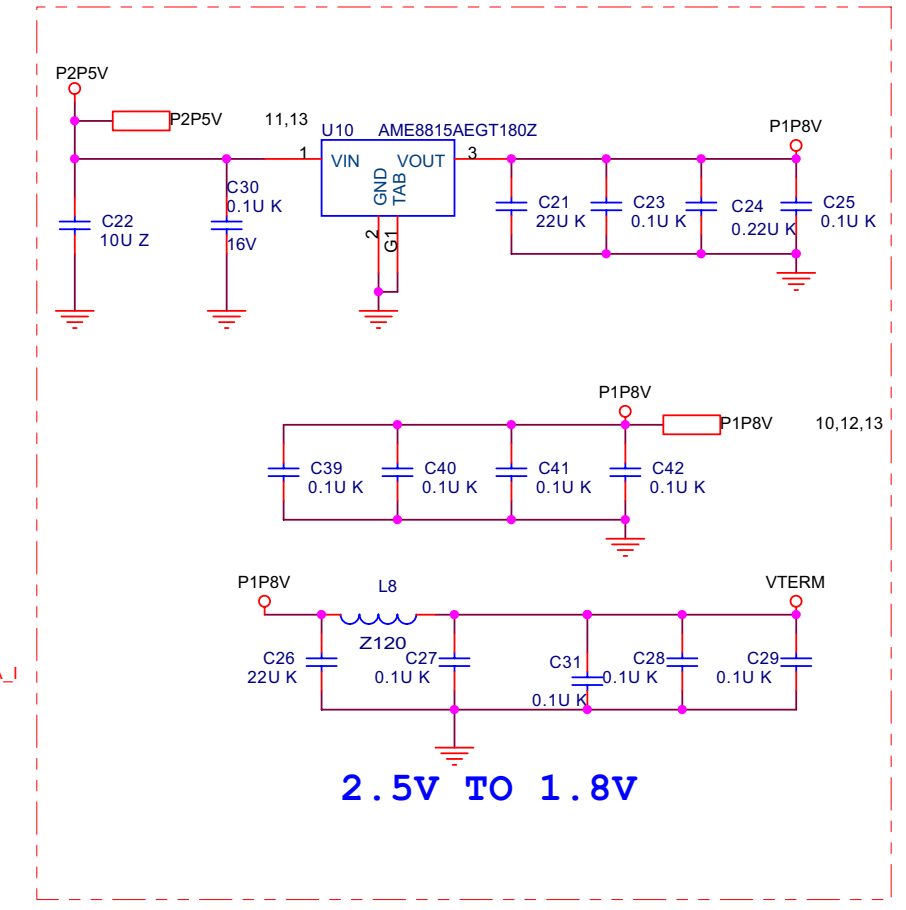
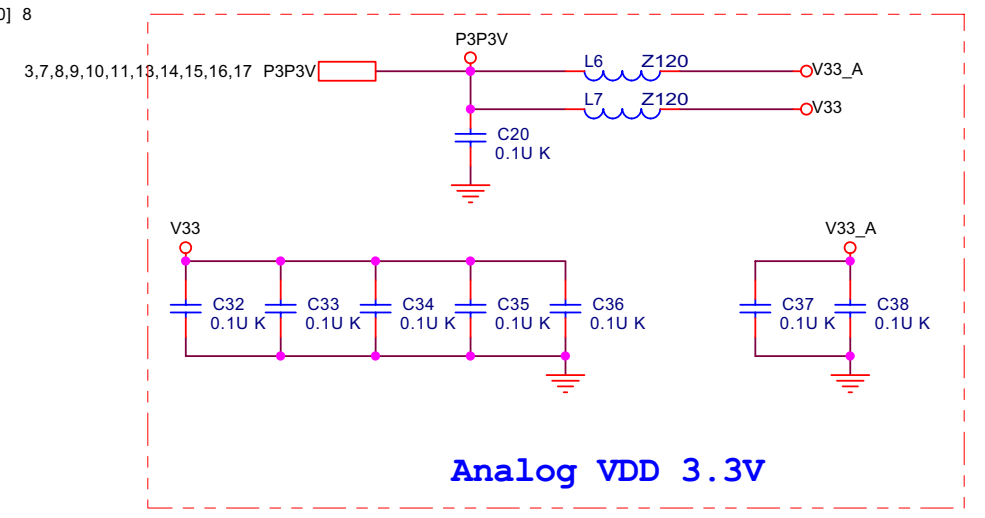
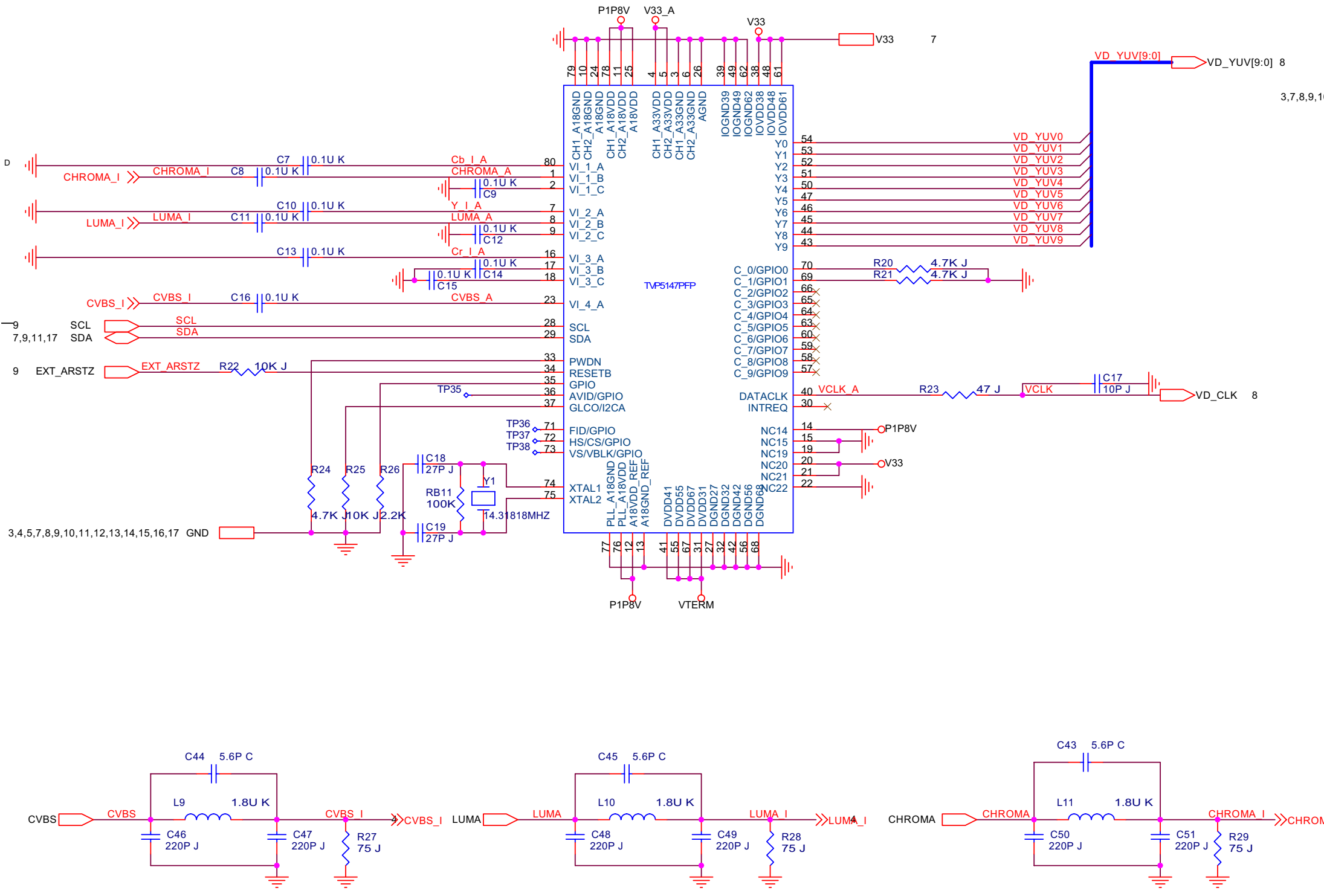

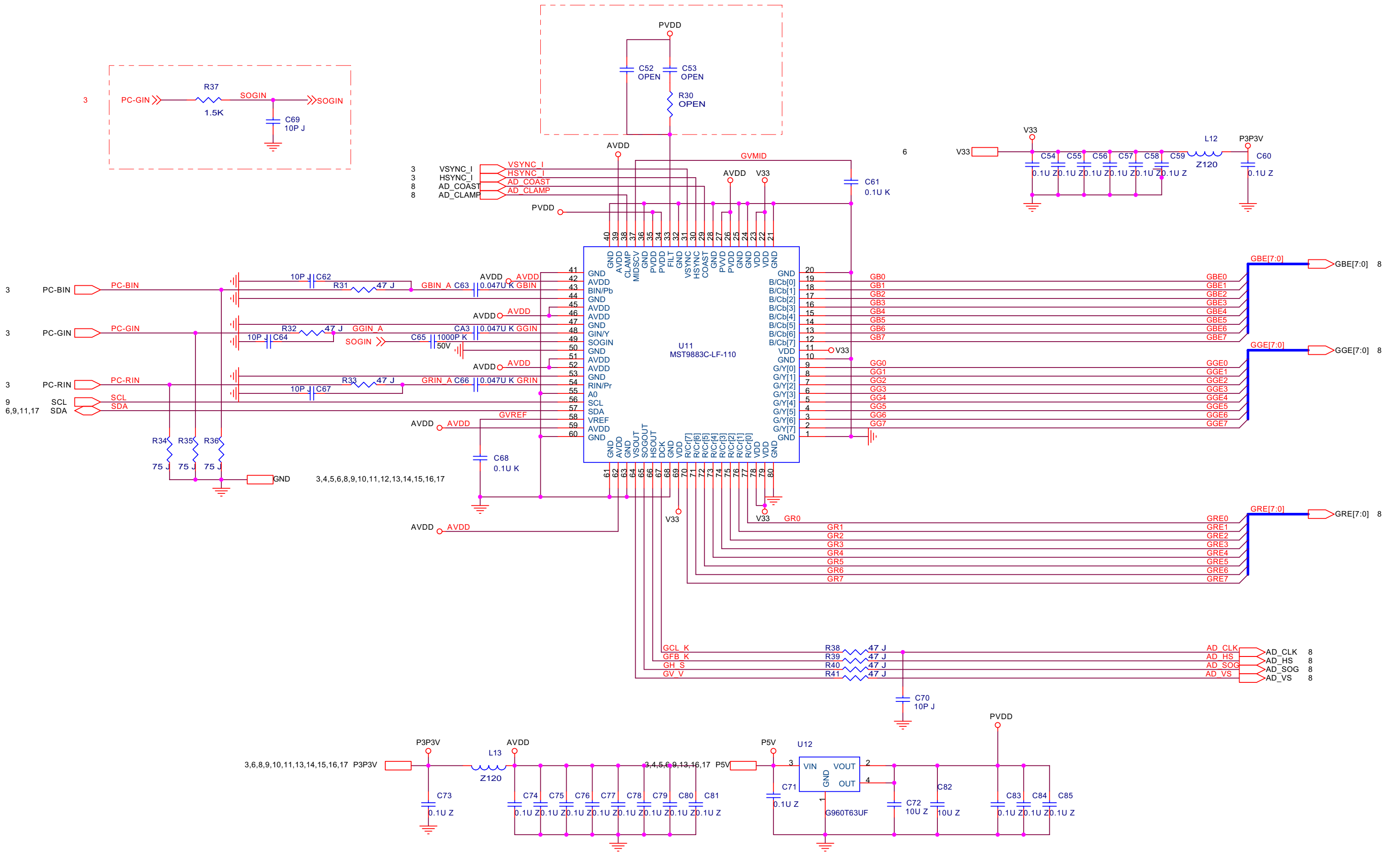

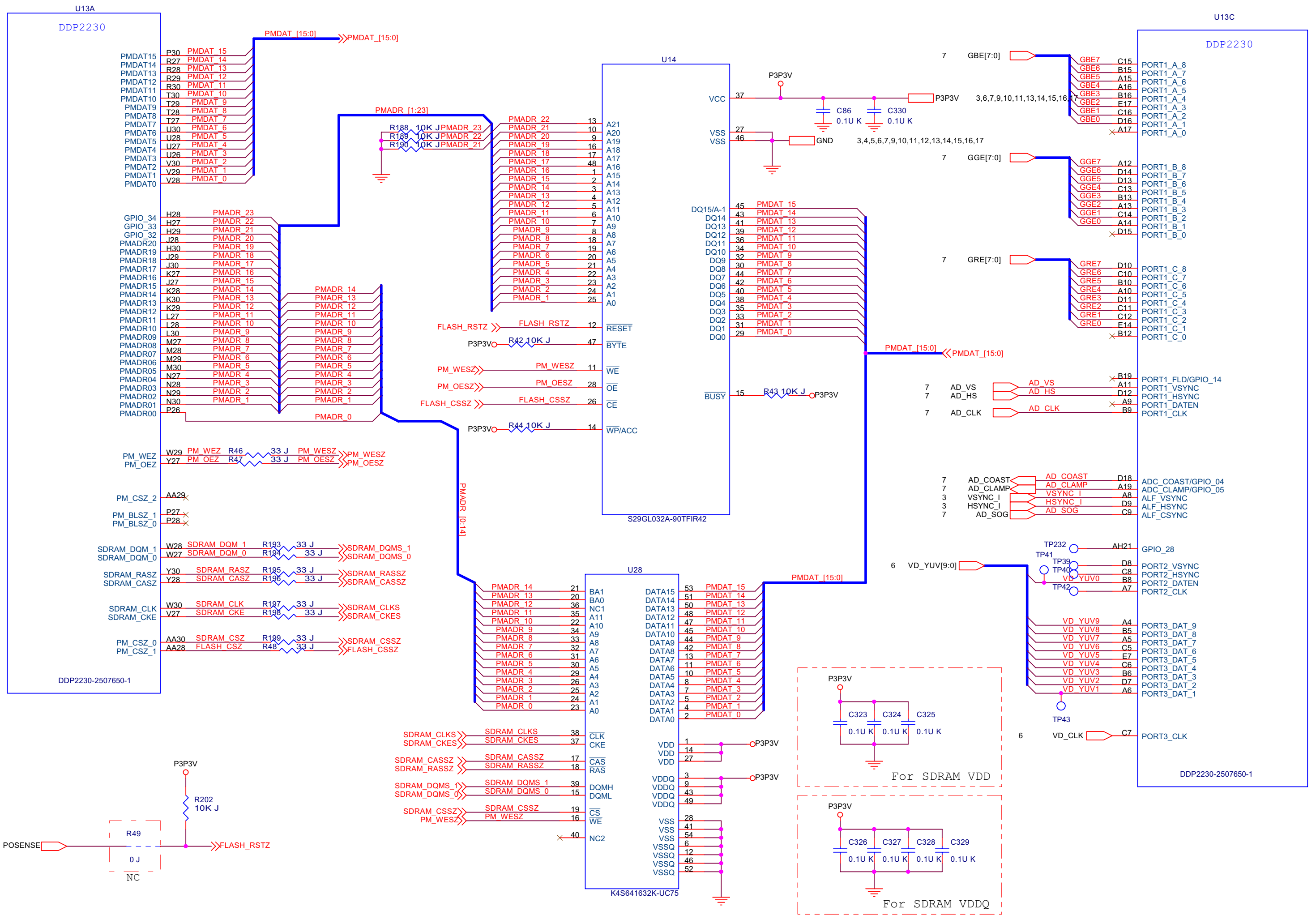

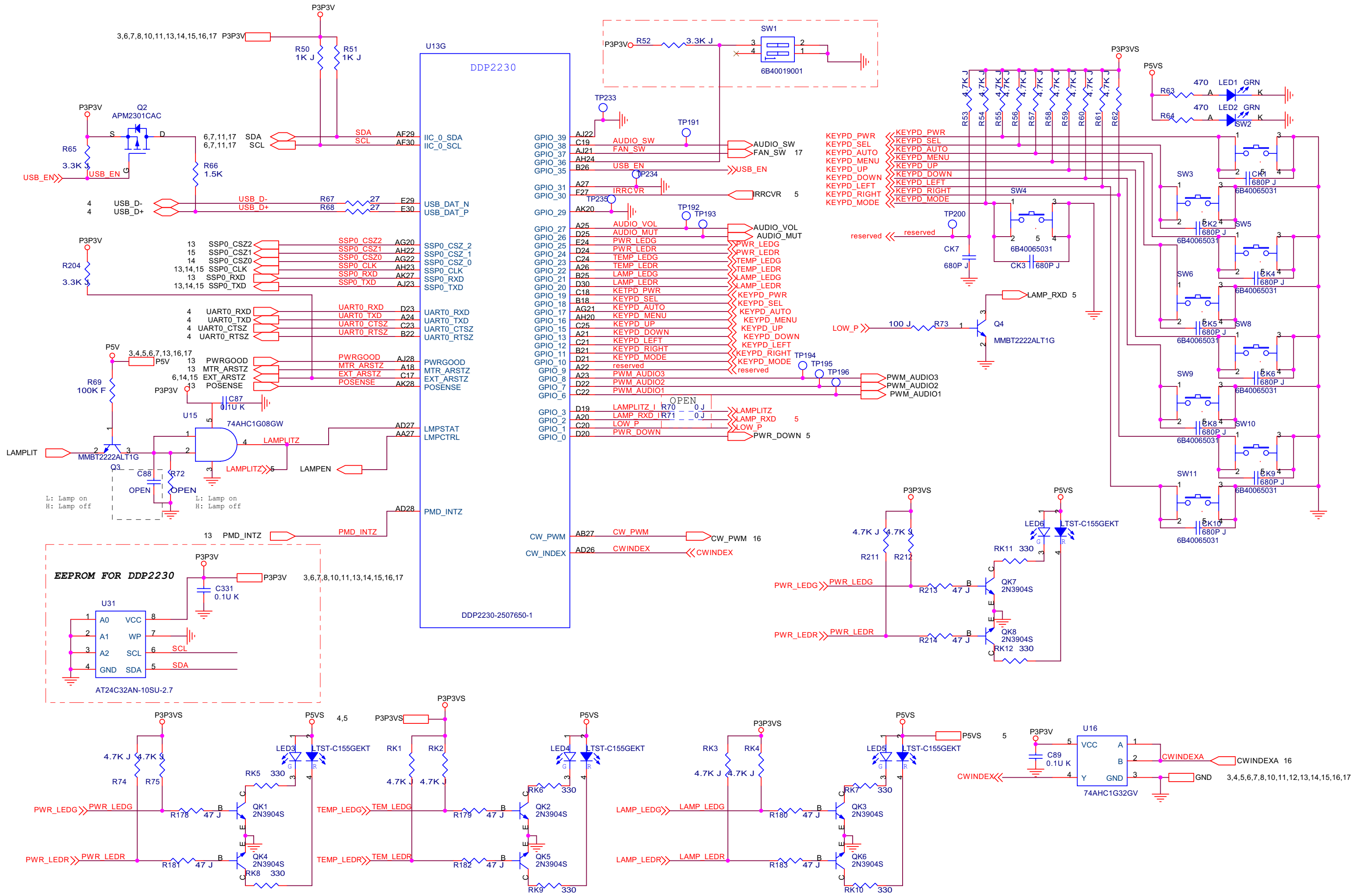

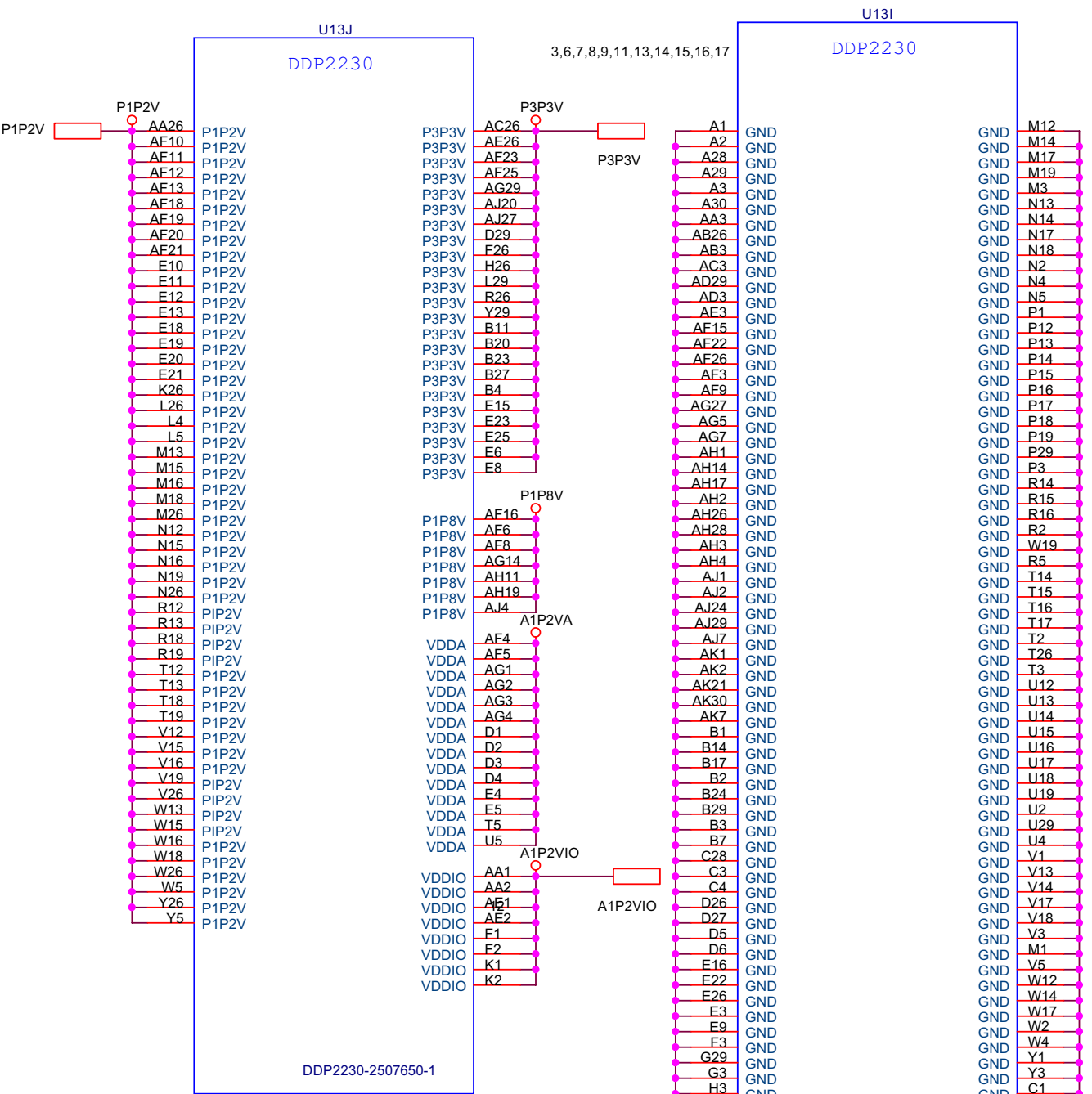

3,4,5,6,7,8,9,11,12,13,14,15,16,17 GND

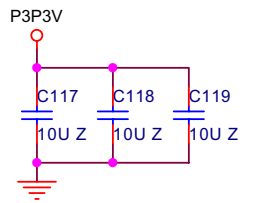
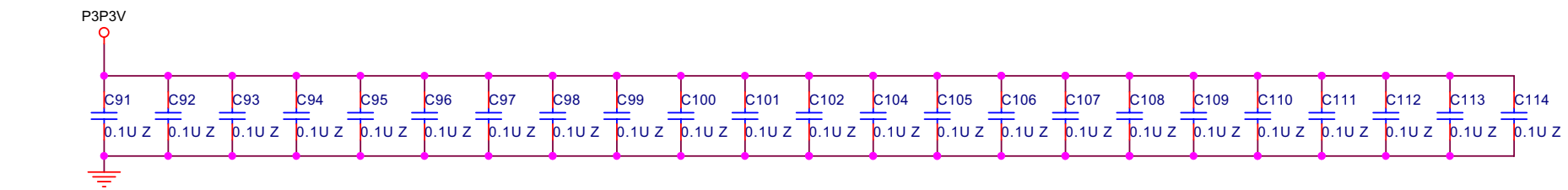
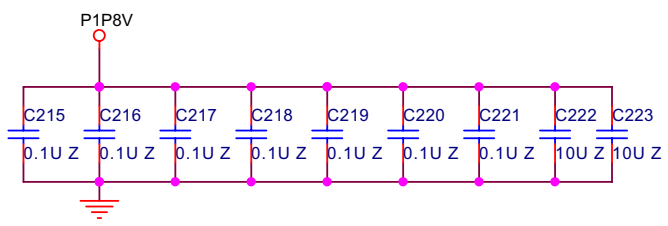
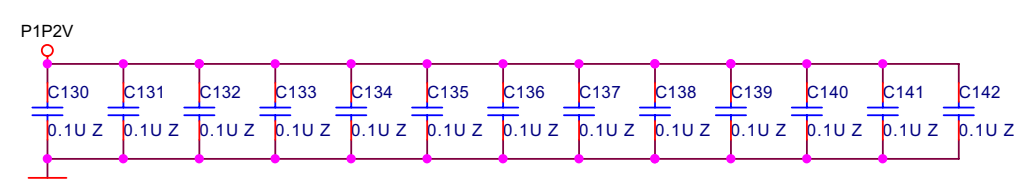
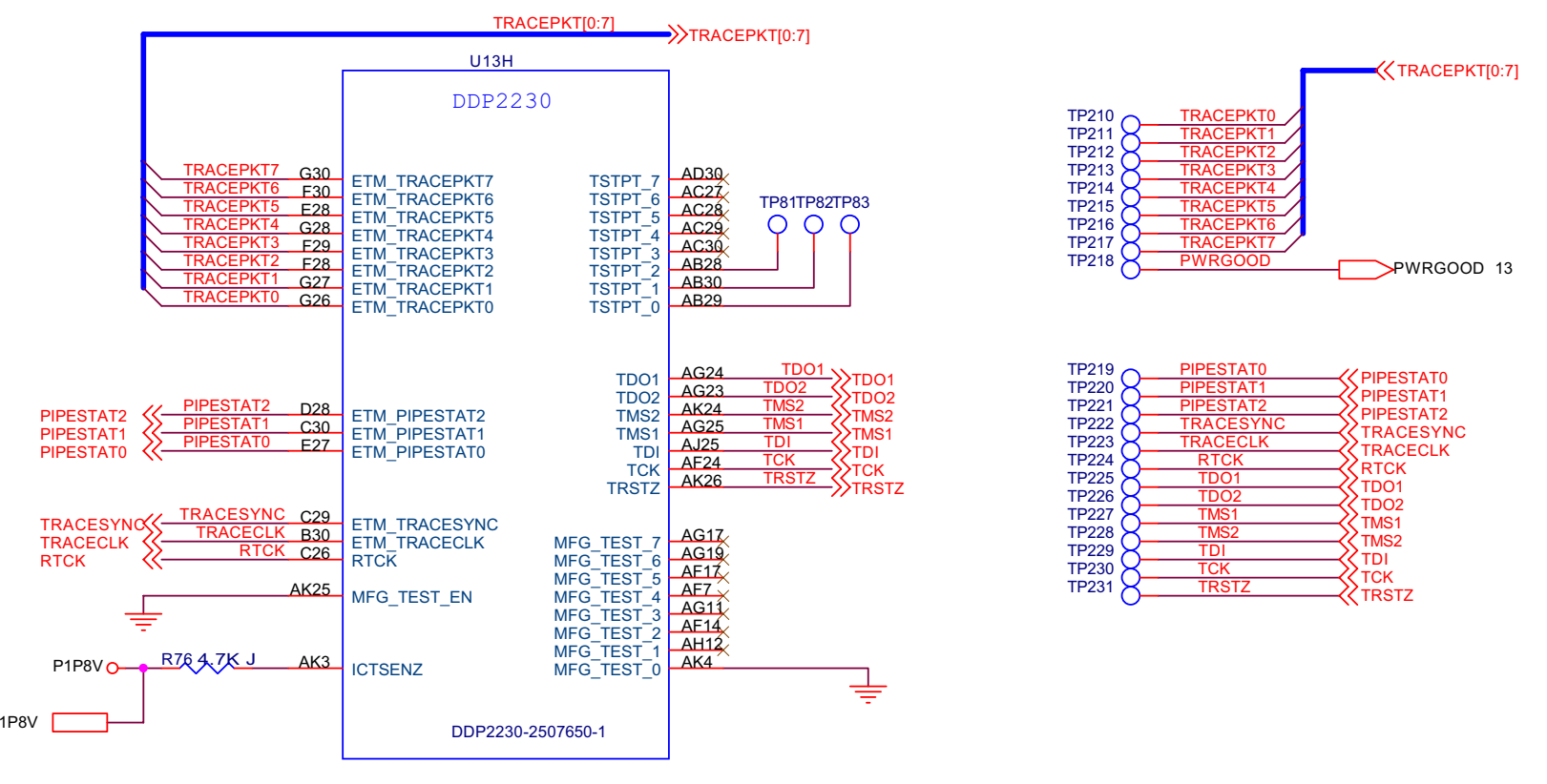
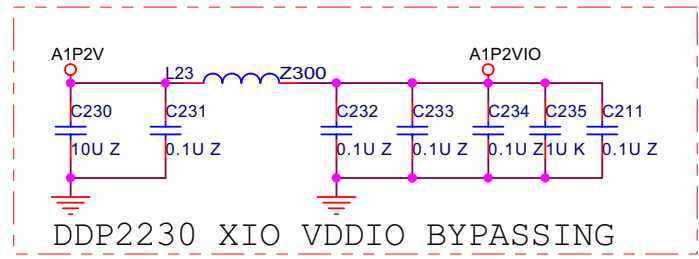
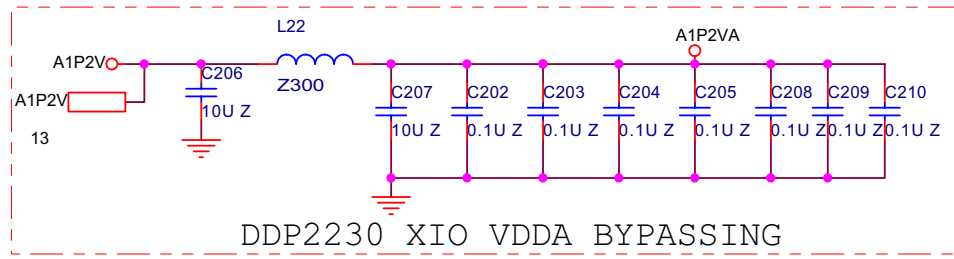
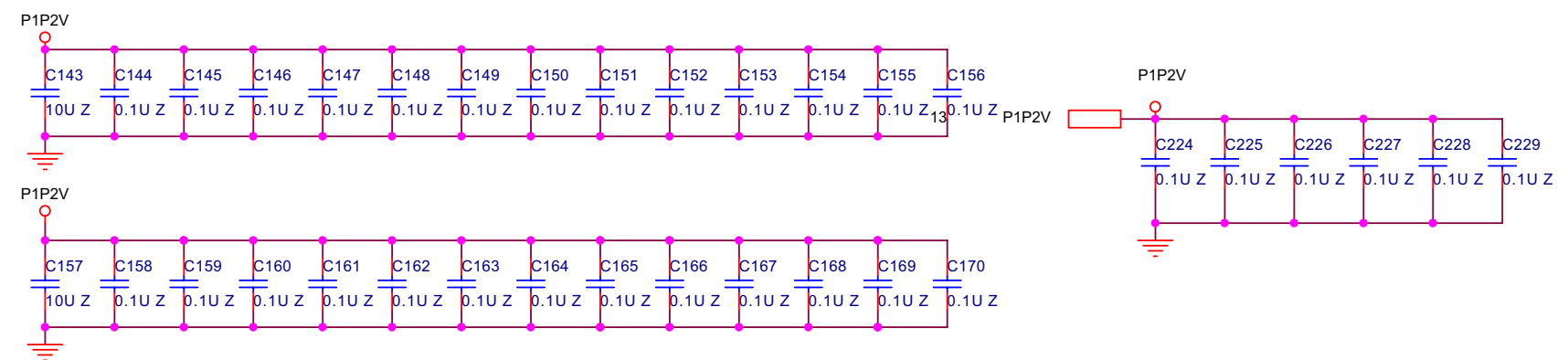

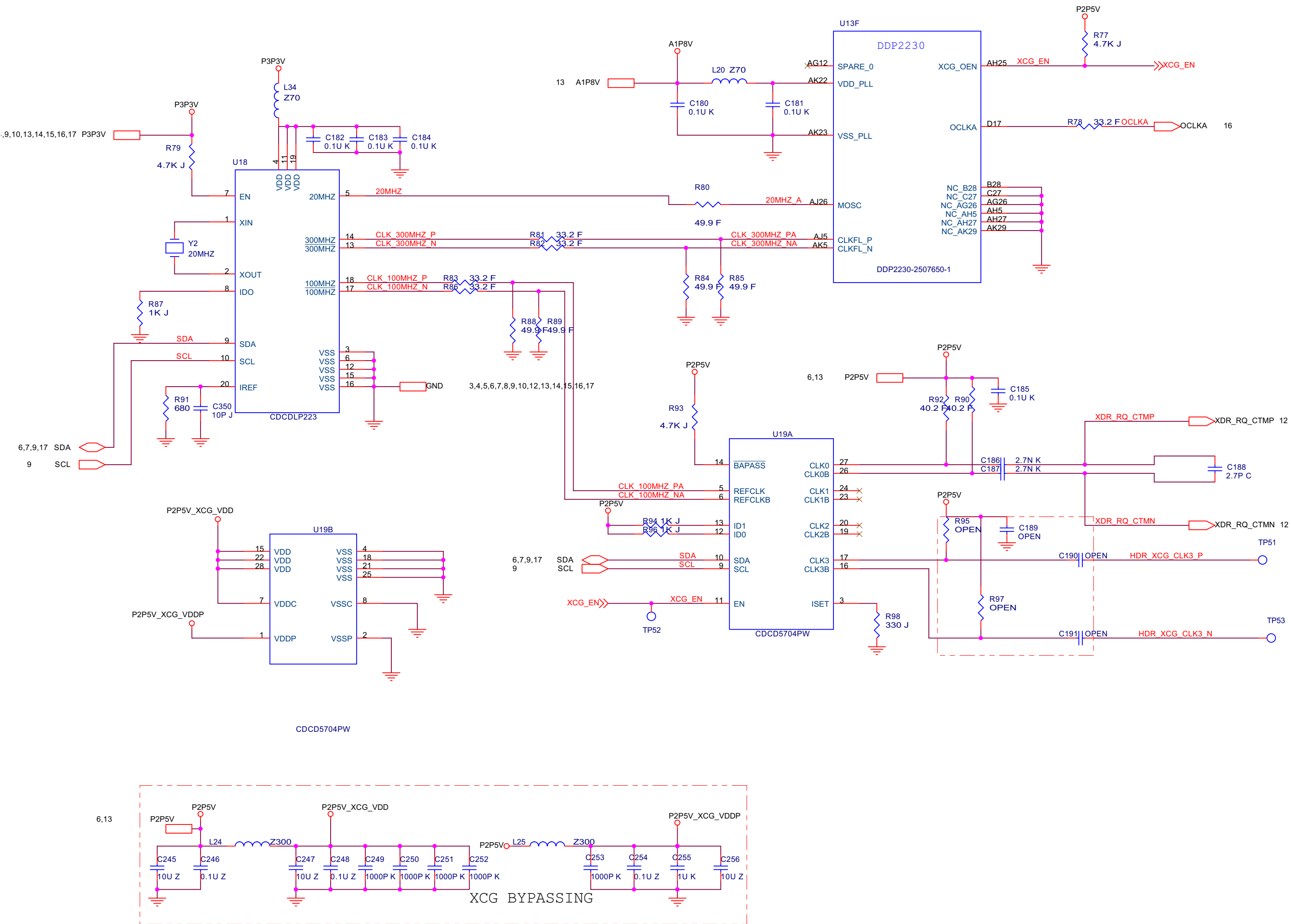

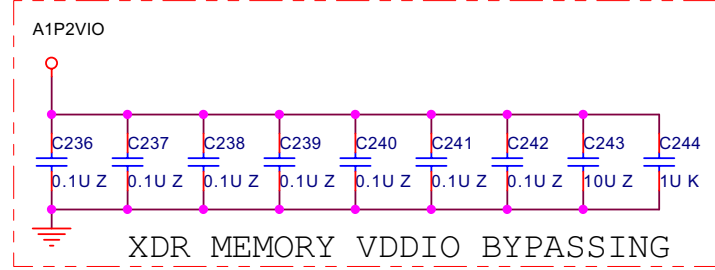
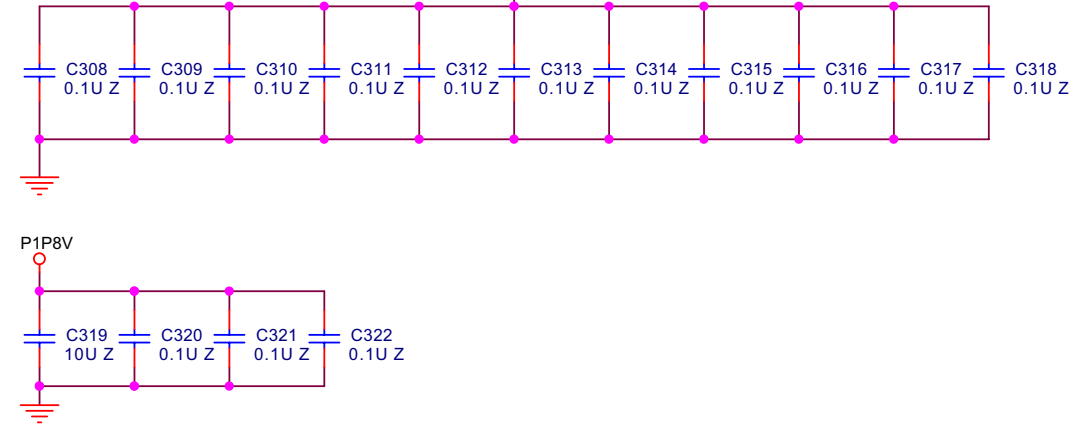
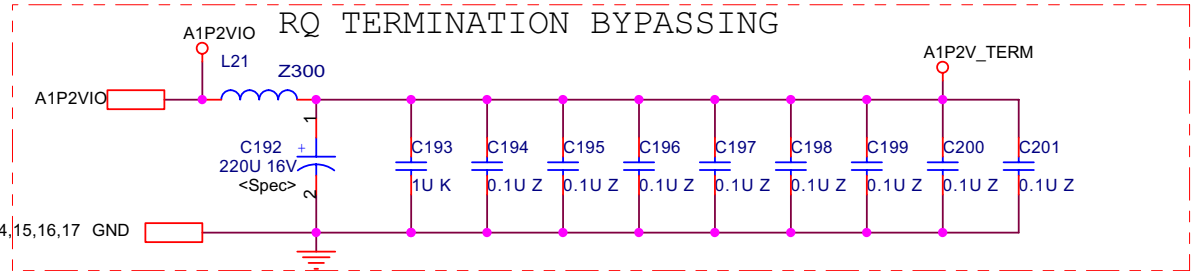
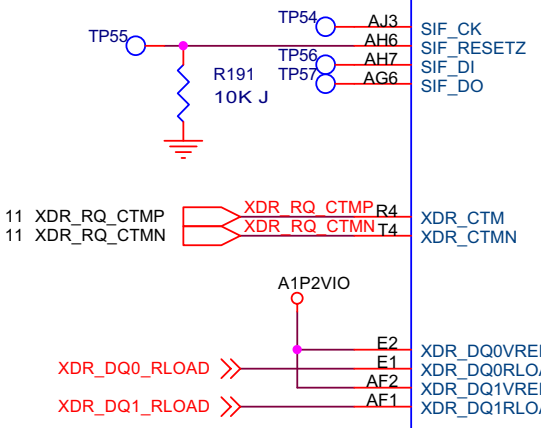
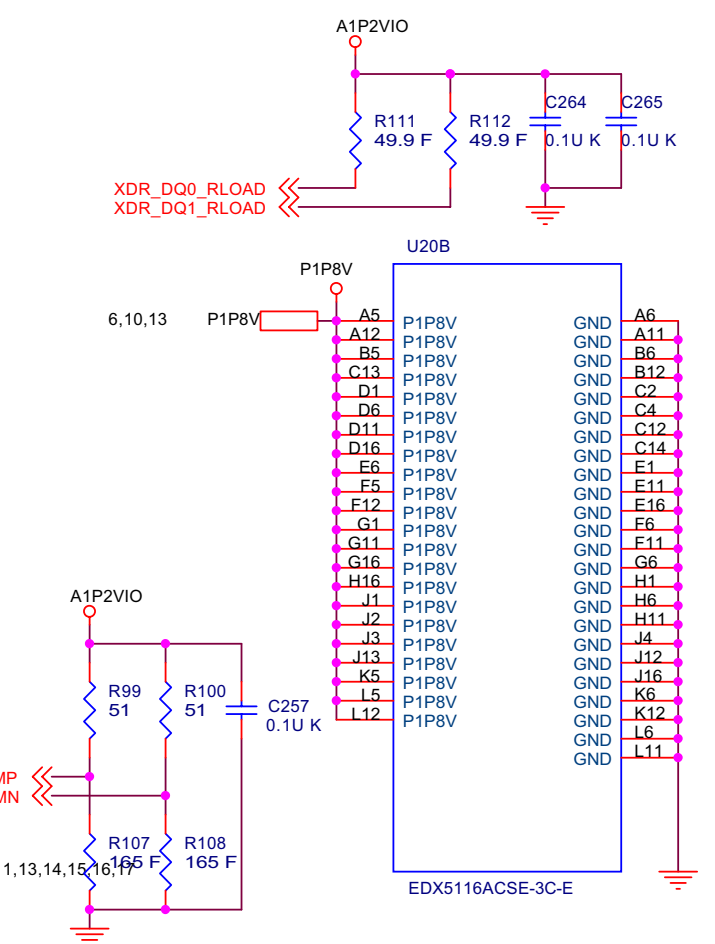
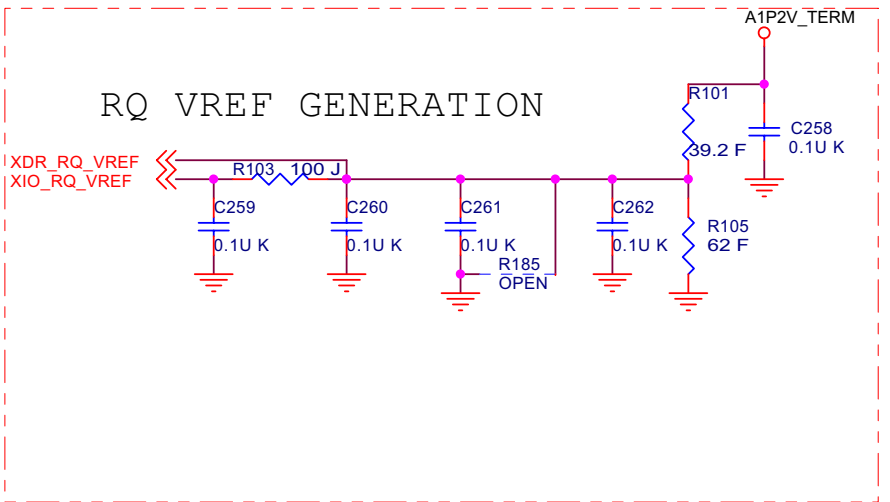
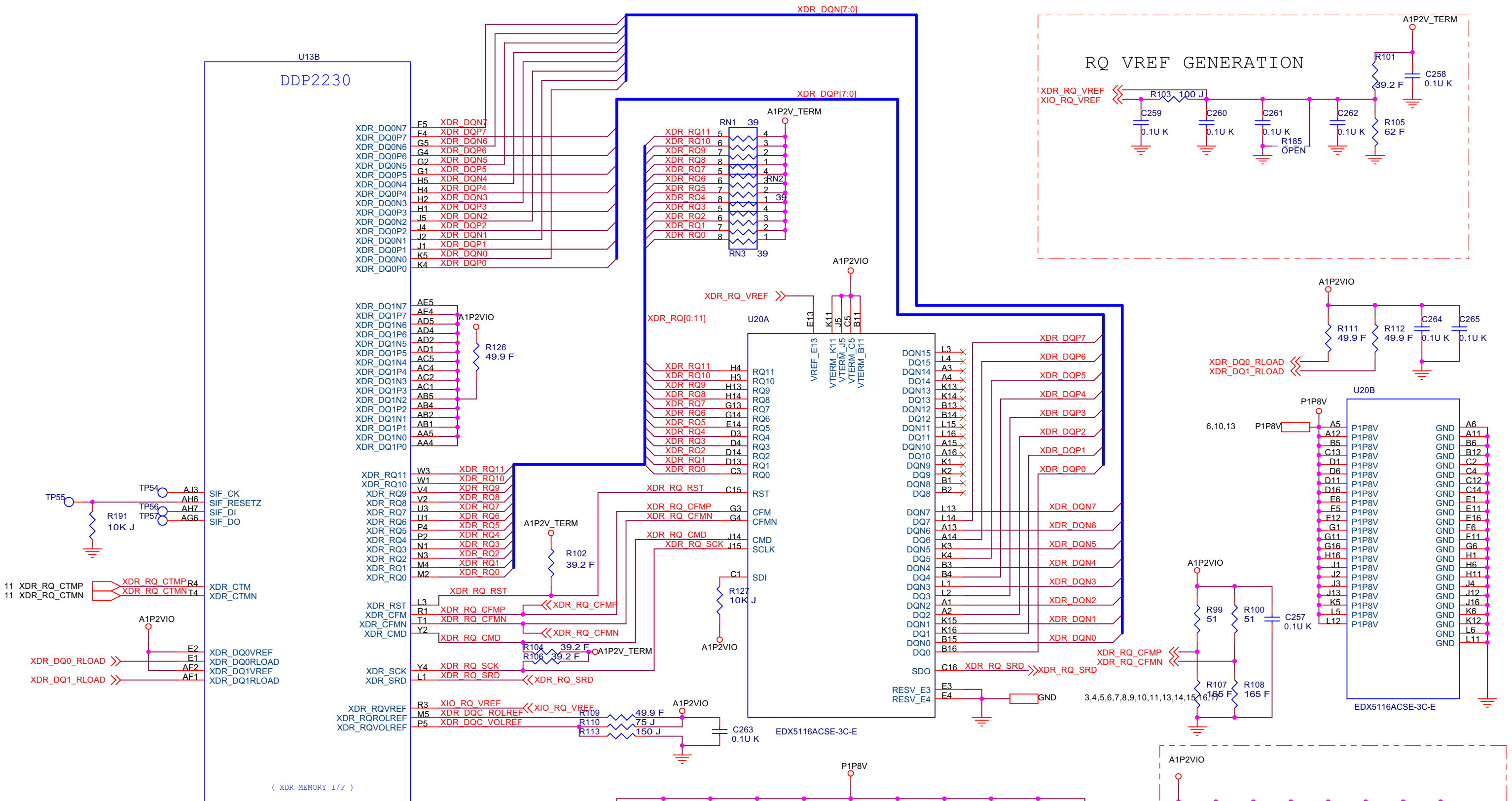



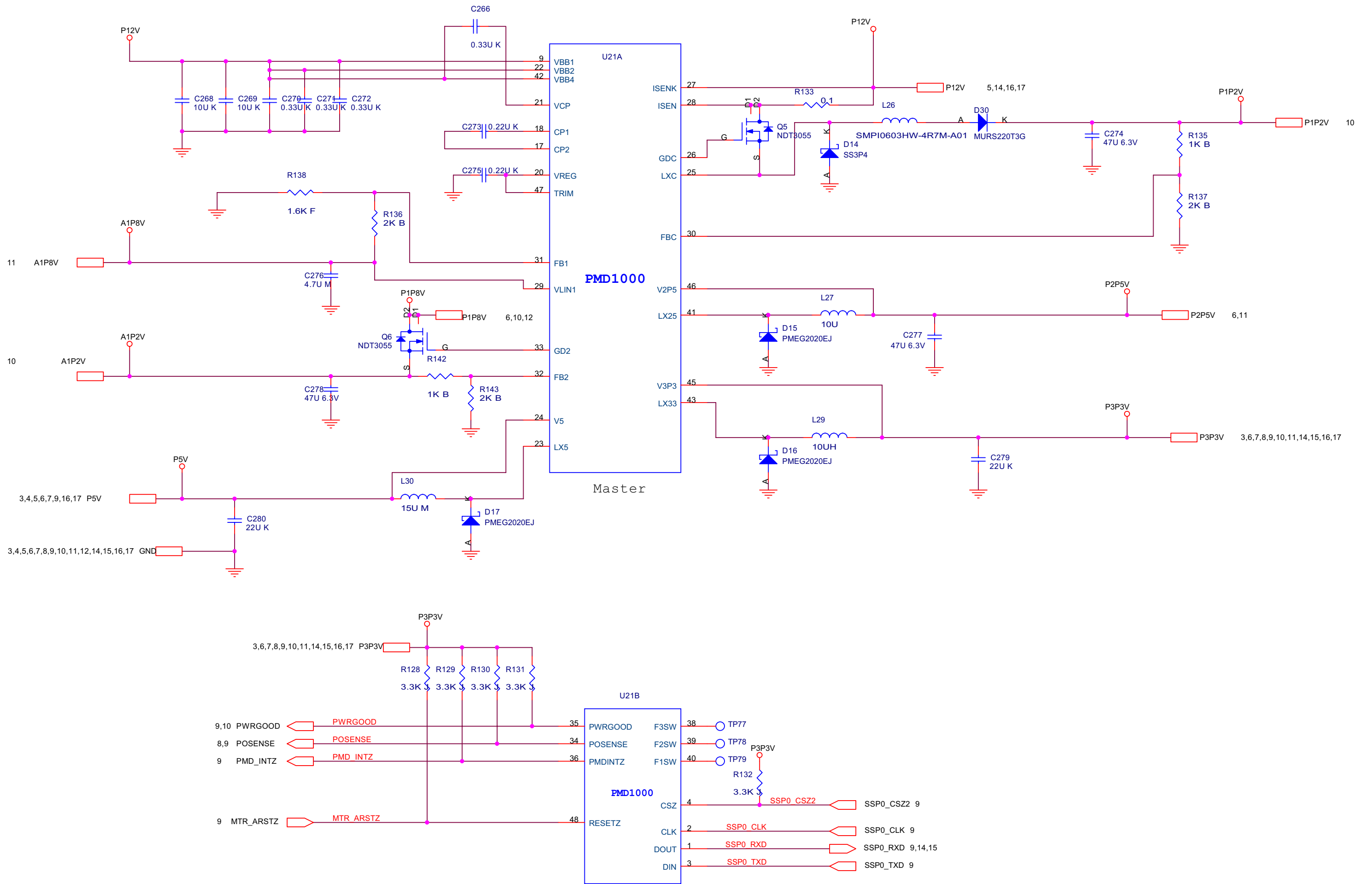

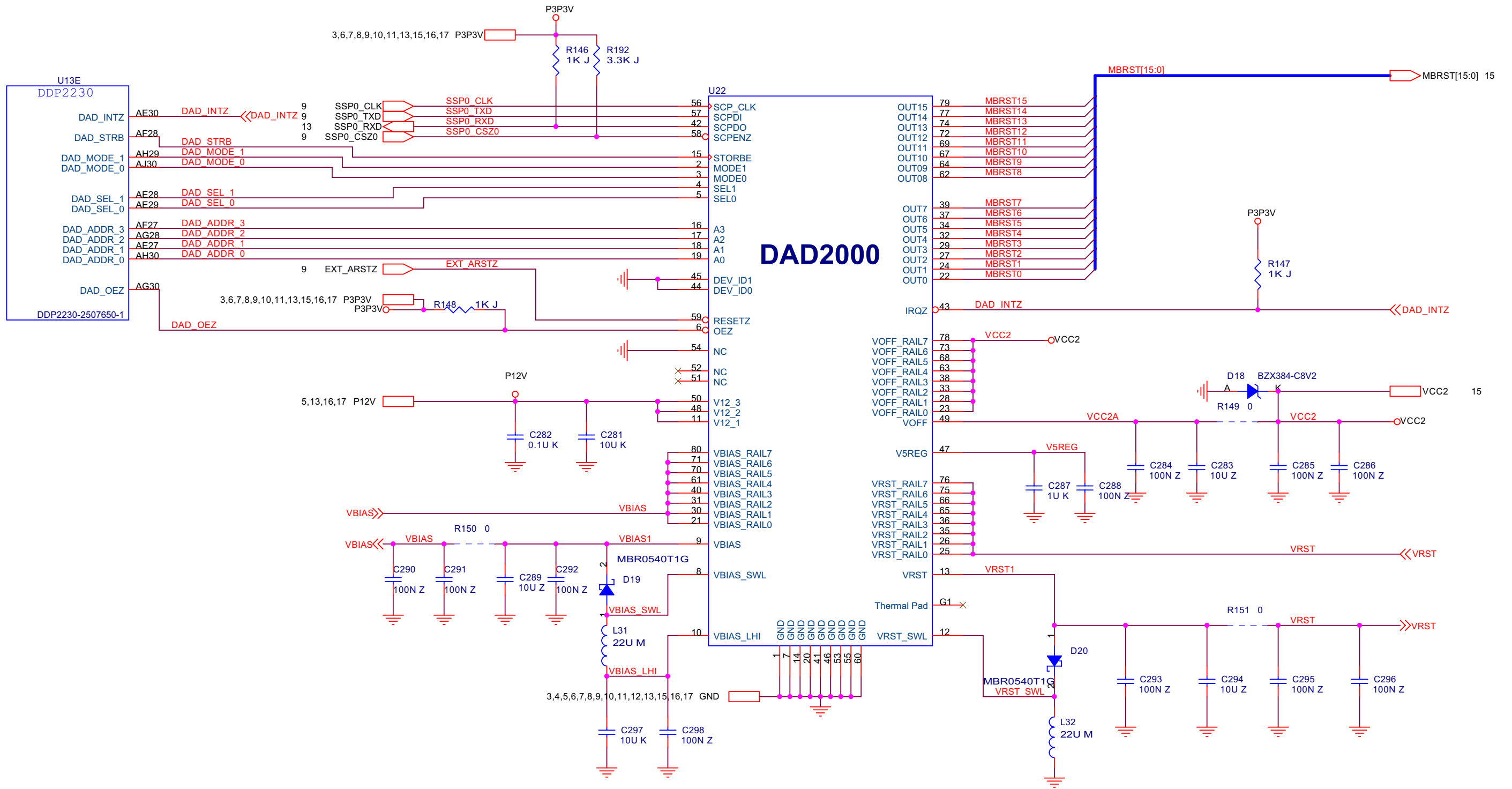

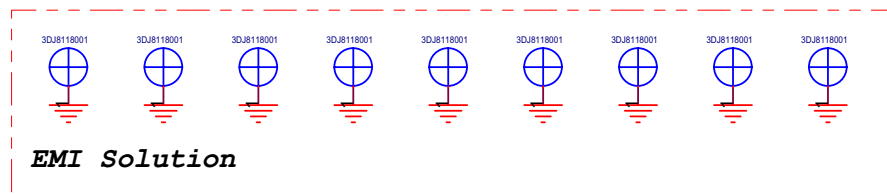
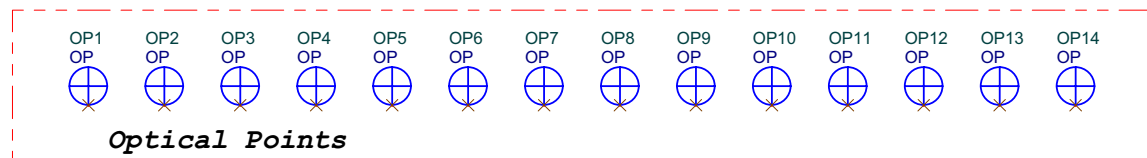
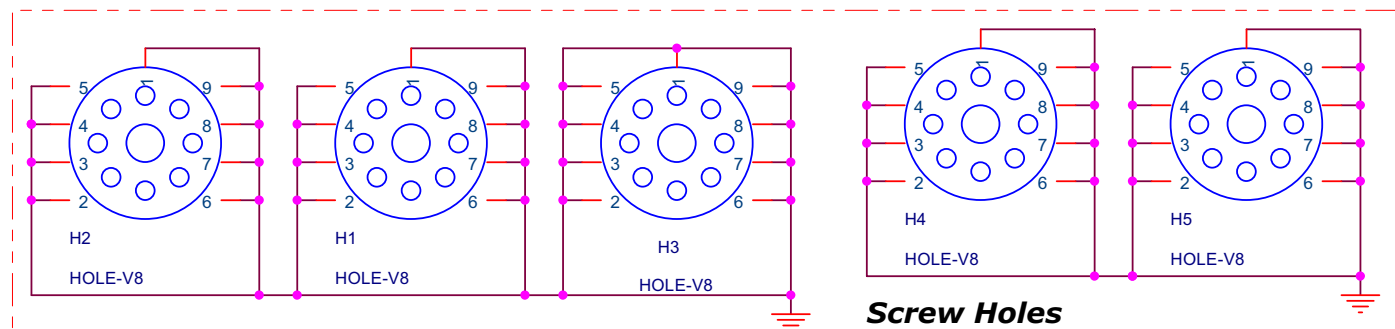
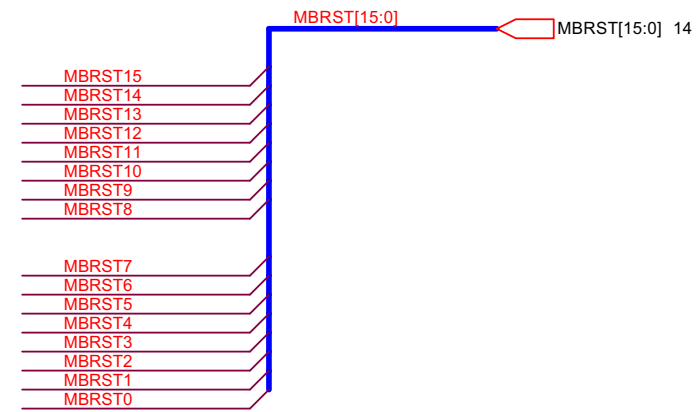
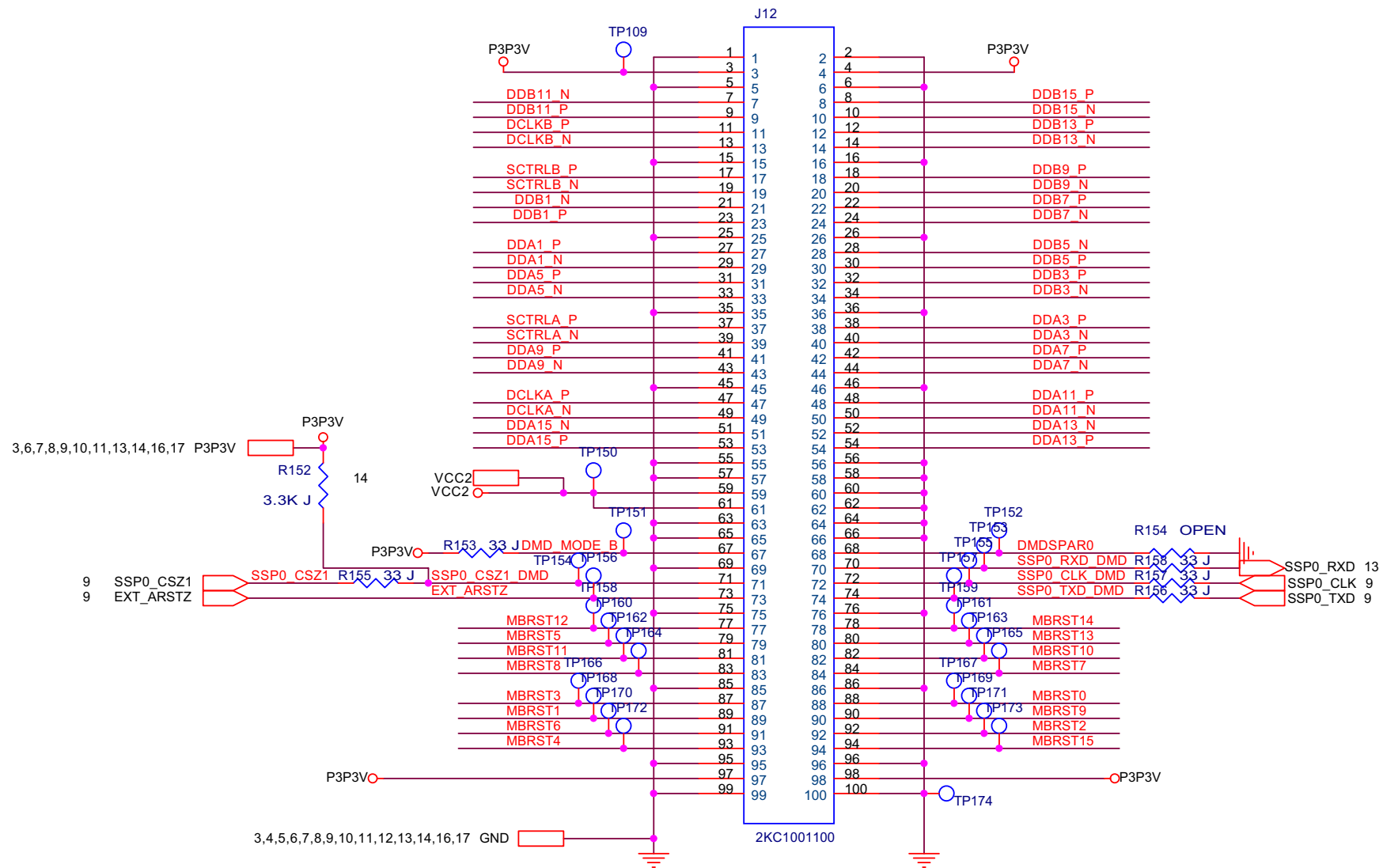
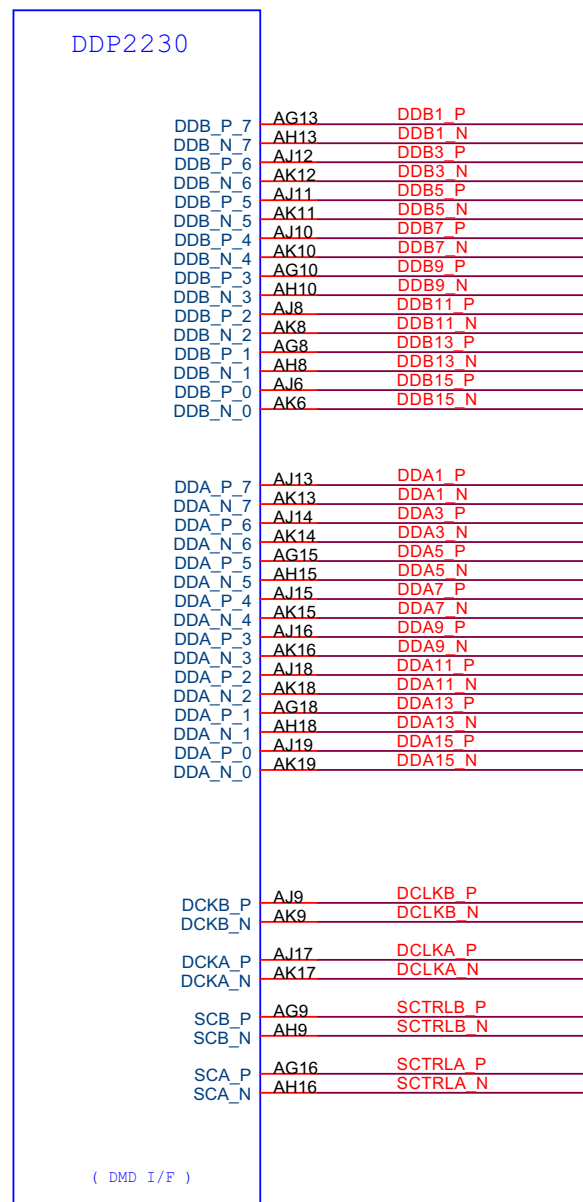

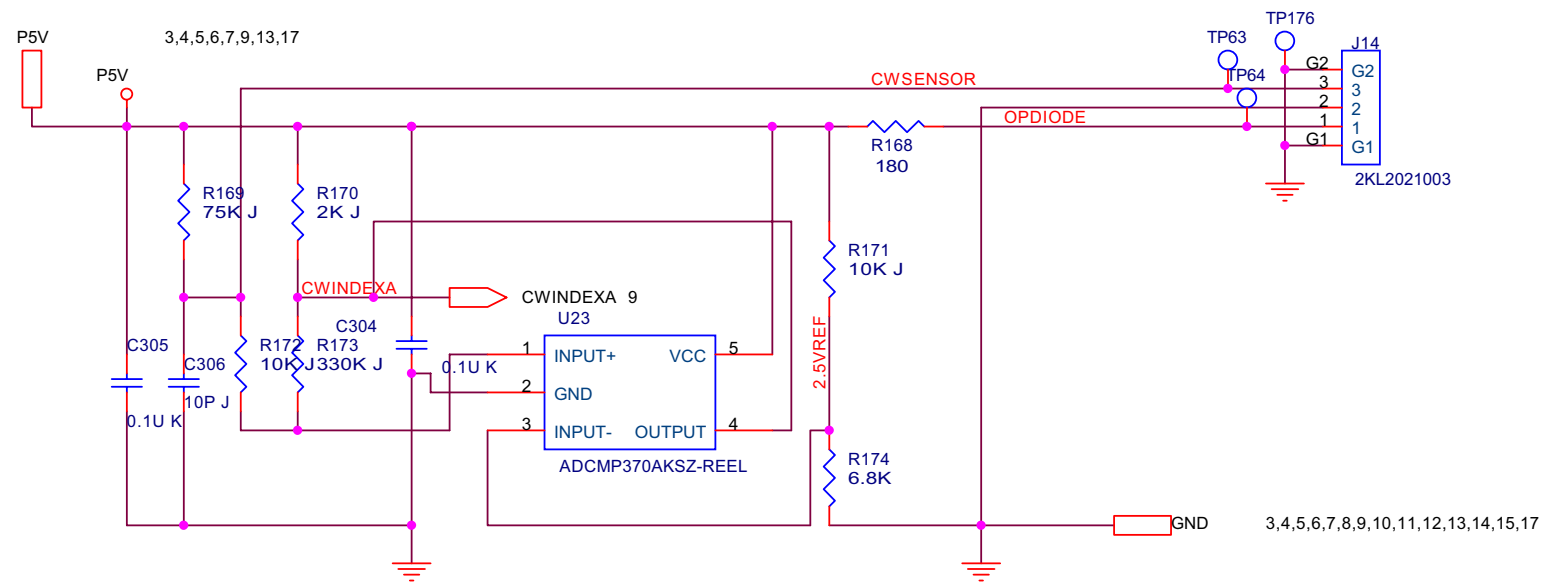
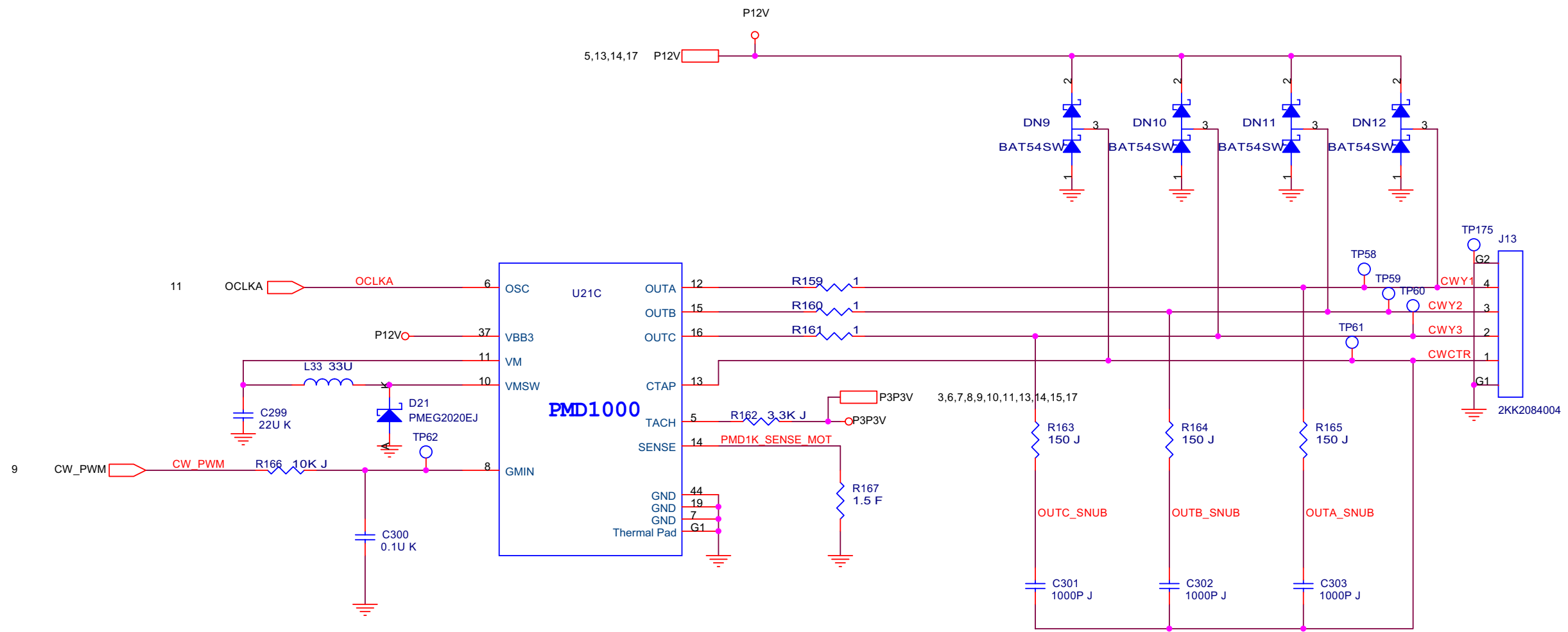

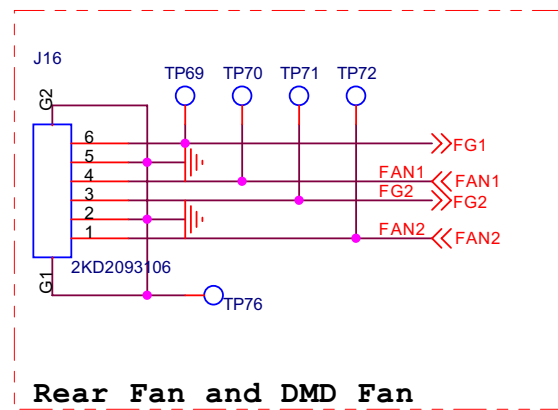
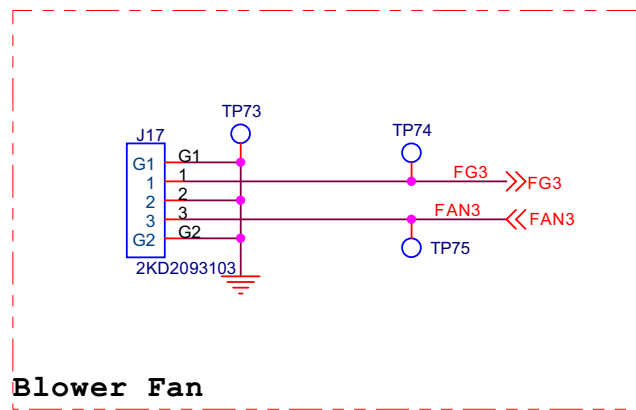
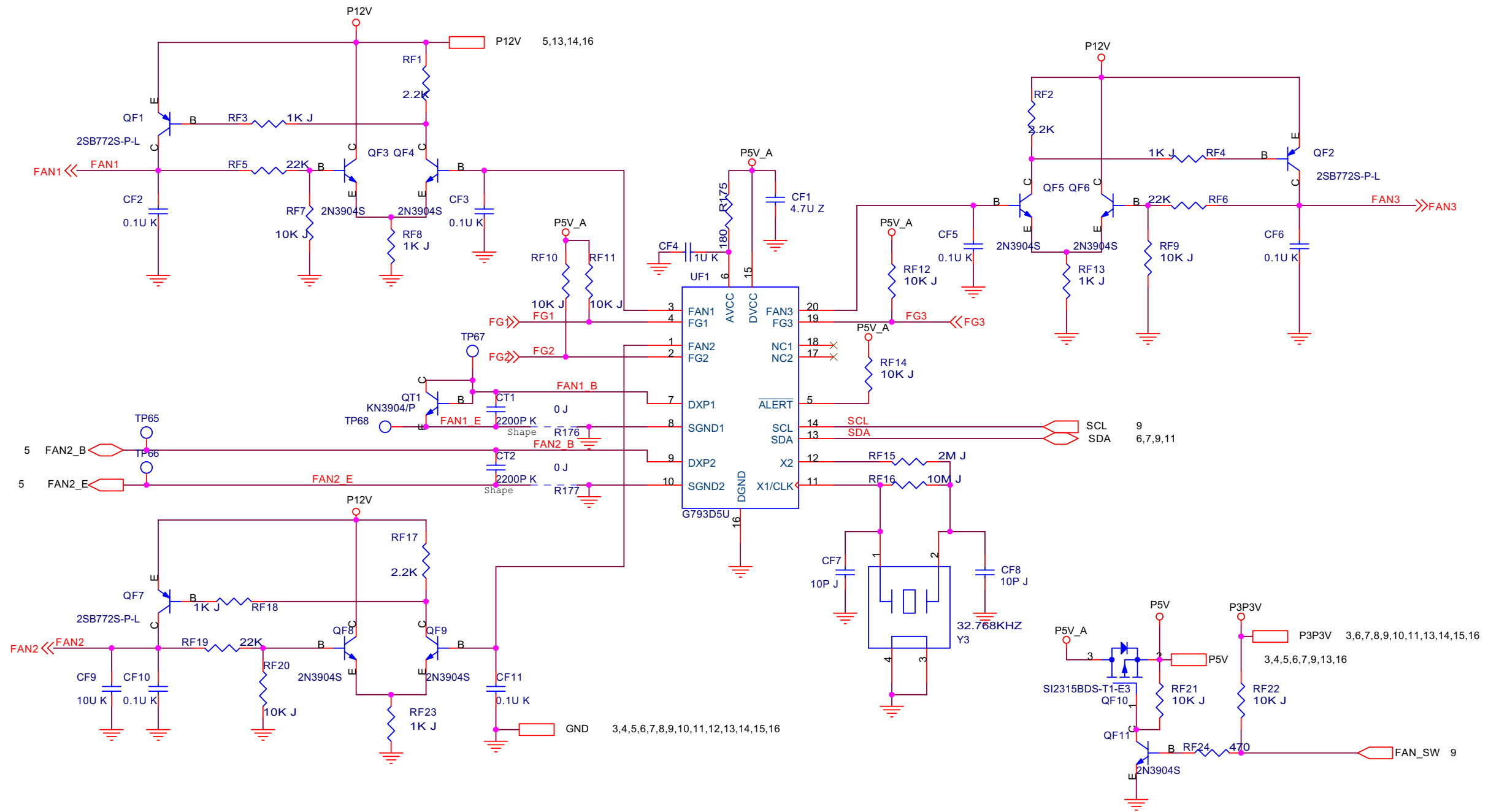

# 9. PCB Layout Diagrams

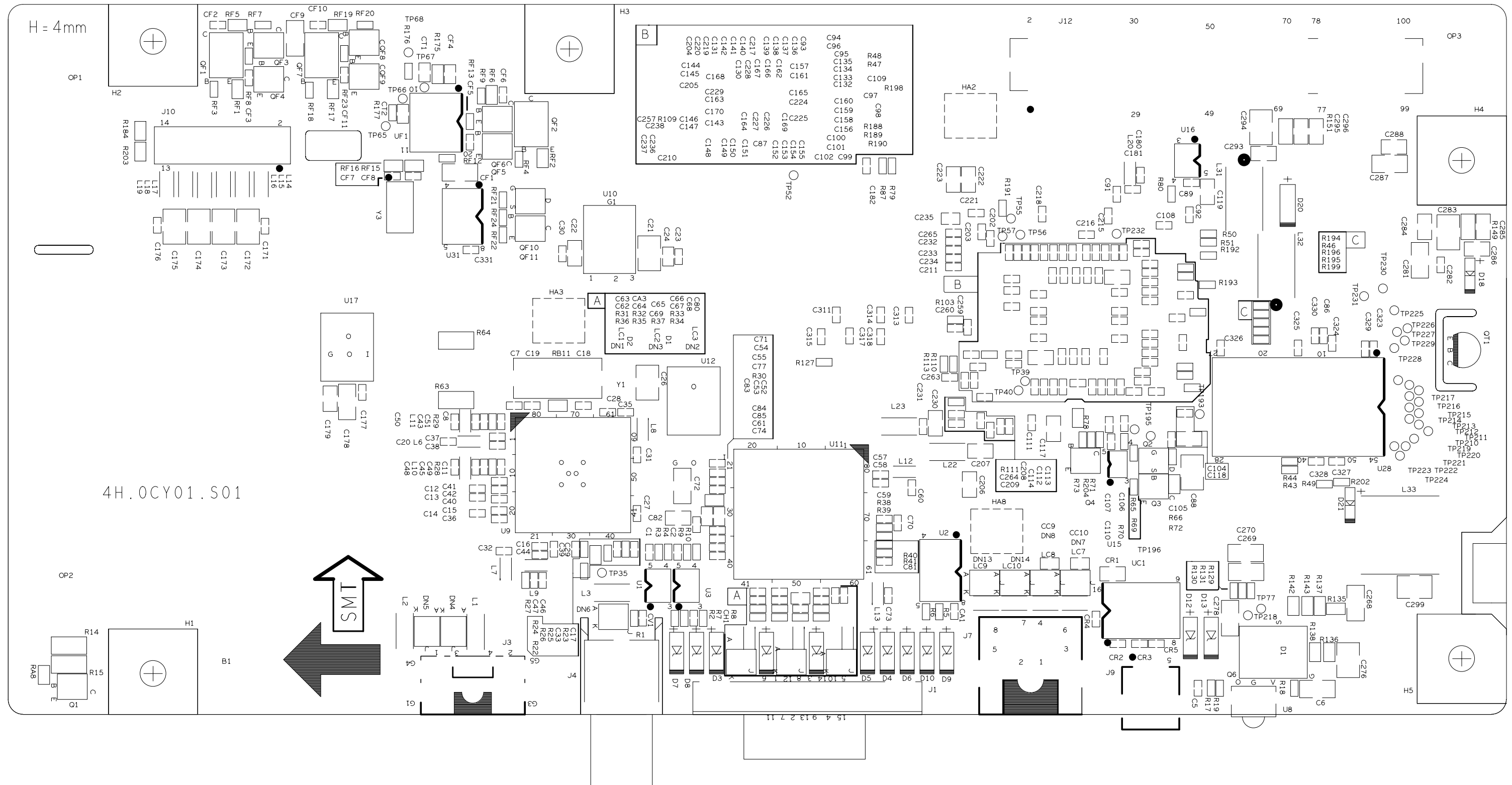

Layer: SILKSCREEN_TOP	Part No.: 4H.0CY01.S01
Filename: M/B	Date: MAY-17-07' Rev.: 0
Model No.: VG31	Sheet 3 of 16
Doc. No.: 9J.0CY77.000-C3-305-001	

L1: TOP  
 L2: INT1  
 L3: GND1  
 L4: INT2  
 L5: VCC  
 L6: GND2  
 L7: INT3  
 L8: BOTTOM  
 PCS: 201.5x95.5mm  
 PNL: 211.5x191+-0.127mm  
 V: CUTx3, ROUTERx8  
 ZPCS/1PNL  
 THICKNESS: 1.6mm  
 MATERIAL: FR4-1MS

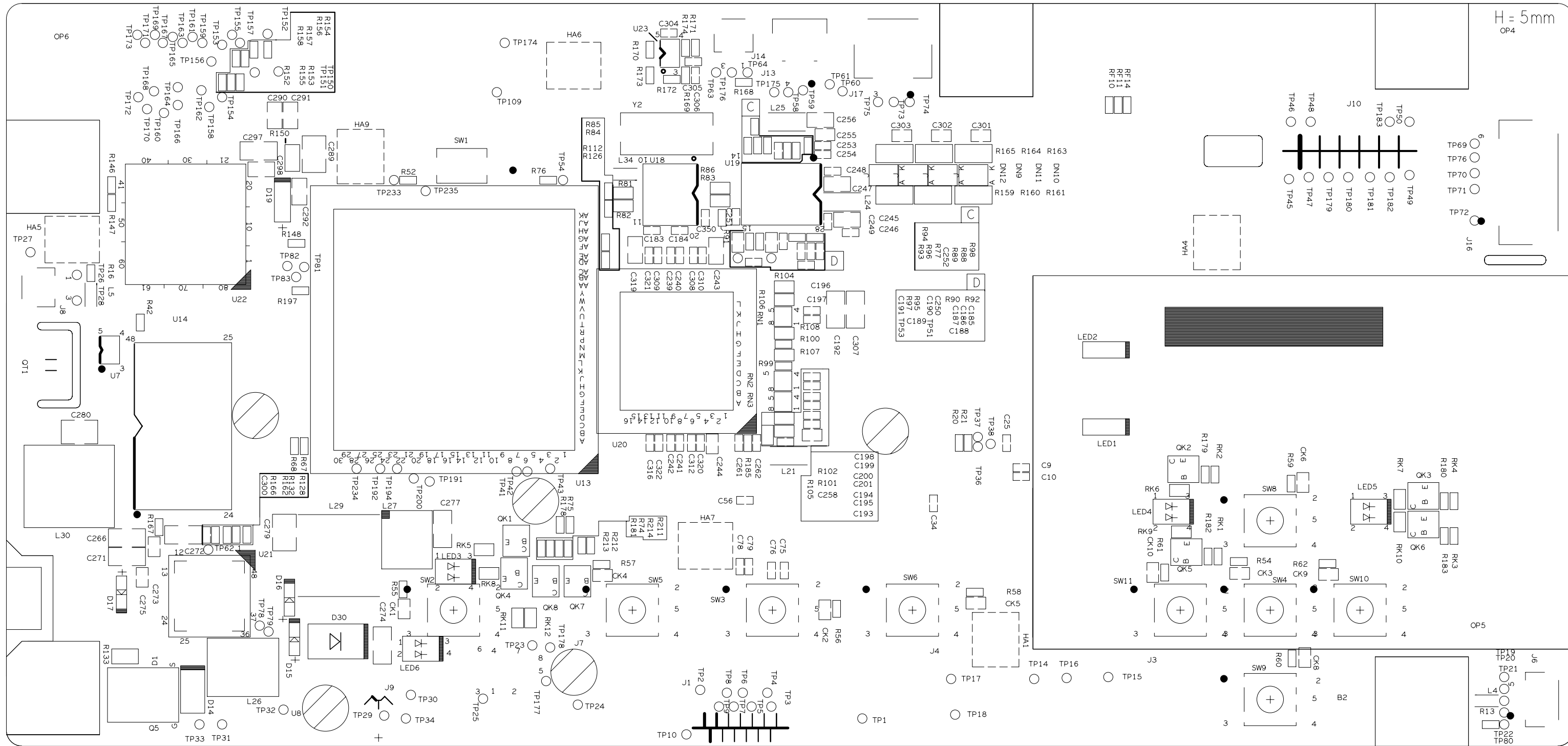

Layer: 2: ILLUMINATION BOTTOM	Part No.: 4H.OCY01.201
File Name: MVB	Date: MAY-17-07, Rev.: 0
Model No.: VG31	Sheet 4 of 18
SPEC: INTS	
V. CUT: 3 ROUTER X8	
PML: 0.125mm	
PC: 501.2x82.2mm	

L8: BOTTOM  
 L7: INT3  
 L6: GND5  
 L5: VCC  
 L4: INTS  
 L3: GND1  
 L2: INT1  
 L1: TOP

# 10. Exploded Diagram and Exploded Parts List

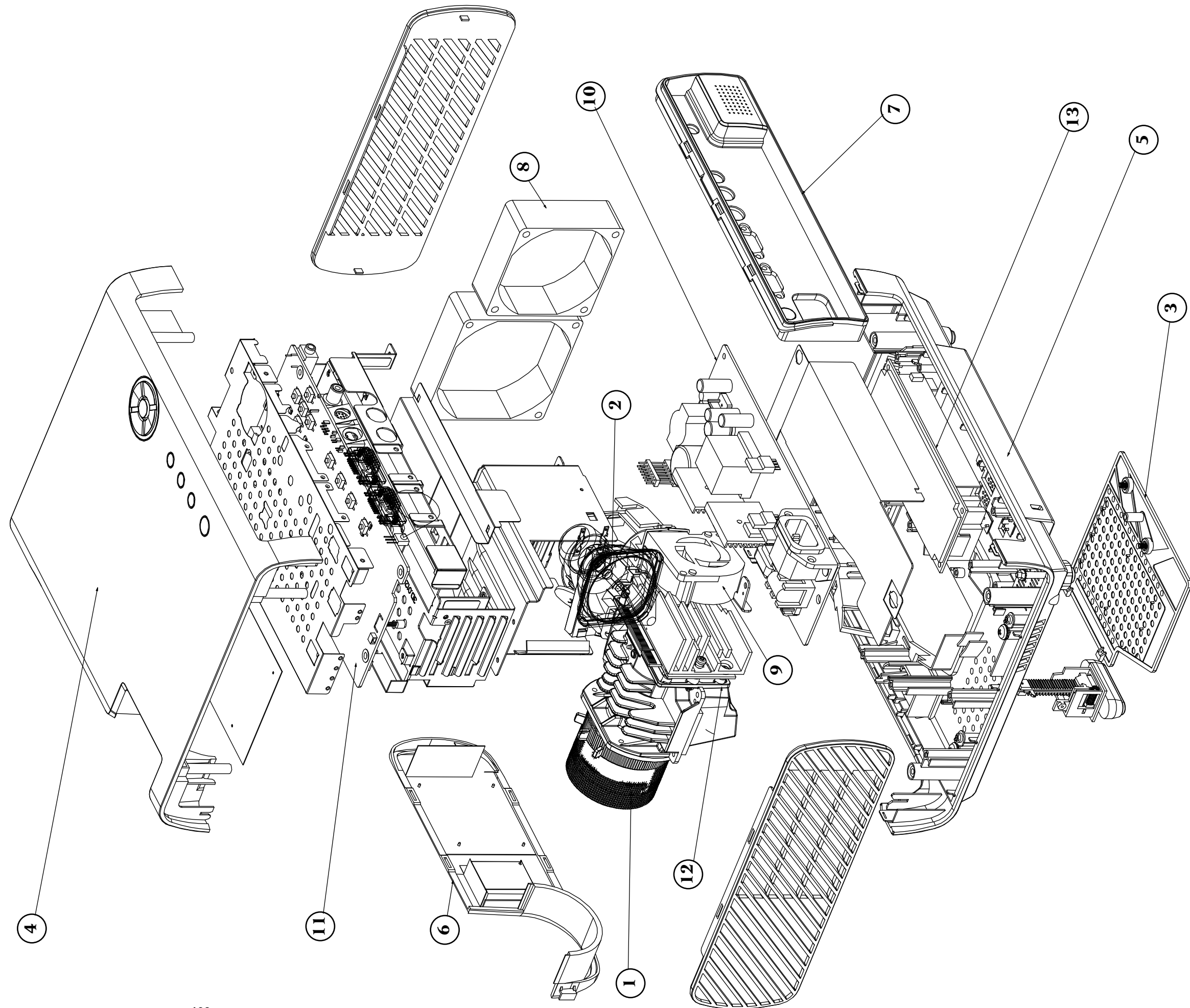

SCALE 0.750



# EXPLODED PARTS LIST (PJ513D-1)

ViewSonic Model Number: VS11959

Rev: 1a

Serial No. Prefix: QTY

Item	ViewSonic P/N	Ref. P/N	Description	Q'ty
1	M-00008166	6E.06001.001	ASSY PL ZOOM MP612 AOCI	1
2	RLC-035	5J.0EB01.001	PACK LAMP RLC-035	1
3	HW-00008365	6K.0EB12.001	ASSY SUB LAMP DOOR WHT PJ513D	1
4	C-00008740	6K.0EB06.001	ASSY UPPER CASE PJ513D	1
5	C-00008742	6K.0EB07.001	ASSY LOWER CASE PJ513D	1
6	C-00008744	6K.0EB08.001	ASSY FRONT COVER PJ513D	1
7	C-00008746	6K.0EB09.001	ASSY REAR COVER PJ513D	1
8	M-00008164	2C.10130.051	FAN*2 70*80*25 30MM AD0712MB	1
9	M-00008165	2C.10139.031	FAN50*50*20 200MMAB5012HBMP511	1
10	B-00008774	5E.08040.011	PCBA POWER BD MI MP511+	1
11	B-00008775	5E.0EB01.001	PCBA MAIN BD PJ513D MI 8L	1
12	B-00008776	5E.06023.001	PCBA CHIP BD MP612 MI	1
13	B-00008777	5D.0CY12.001	BALLAST 180W 2.5KV EUC180DV11	1

**Module 2 –ASSY UPPER CASE**

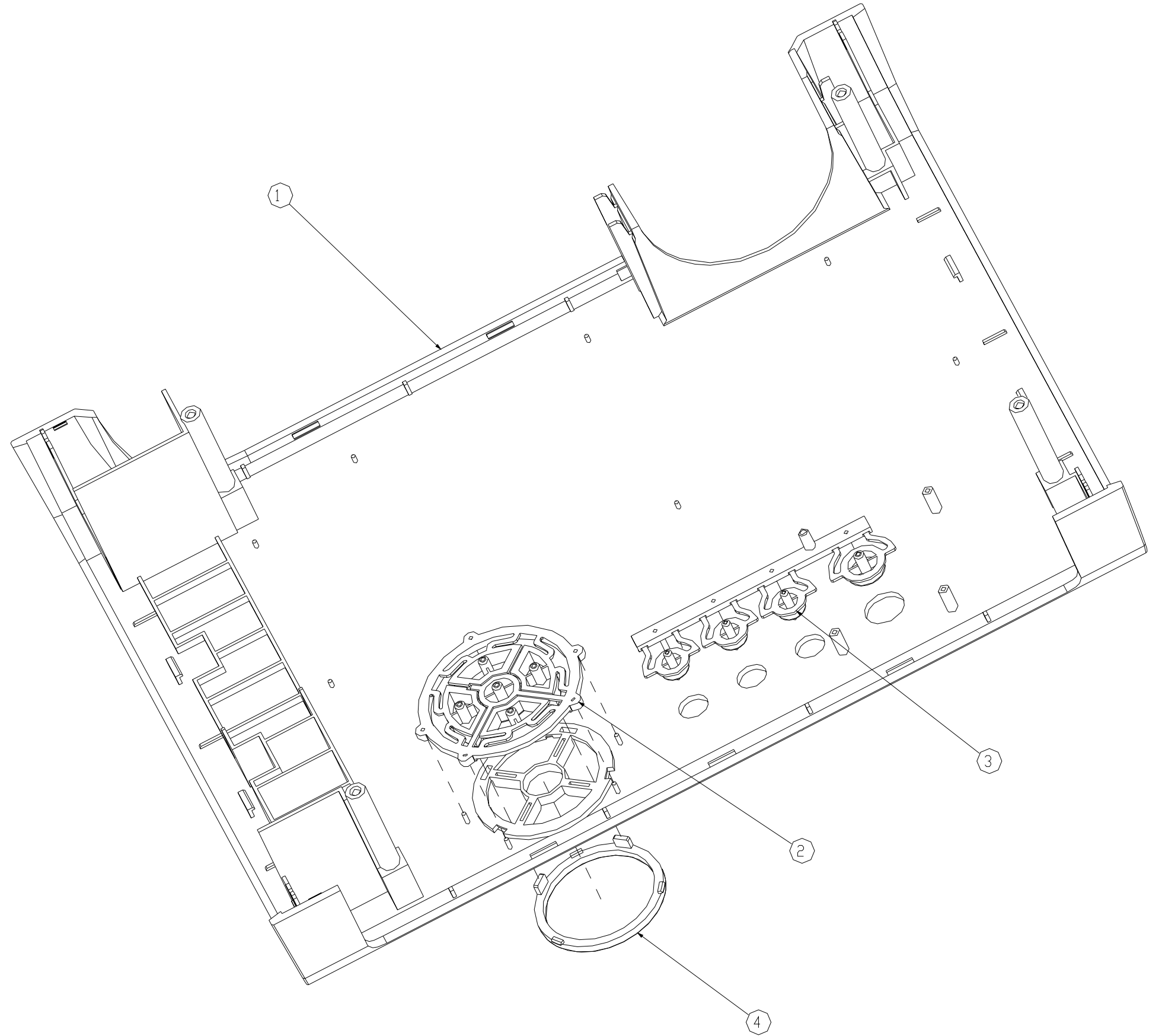

ITEM	PART NO.	DESCRIPTION	Q'TY	REMARK
1	3J.03A01.032	CASE UPPER PC WHITE PJ513D	1	
2	4B.03A01.011	KEY FUNCTION ABS VG31	1	HEAT MELT WITH 3J.03A01.032
3	4B.03A02.002	KEY MODEL ABS VG30	1	HEAT MELT WITH 3J.03A01.032
4	4B.03A03.001	LENS LED PC VG30	1	

**Module 3 –ASSY LOWER CASE**

ITEM	DESCRIPTION	Q'TY	REMARK
1	CASE LOWER PC WHITE PJ513D	1	
2	NUT INSERT M4x15L D6.3 BRASS	3	MOLD IN 3J.OEB01.001
3	NUT INSERT M3x6L D4 BRASS	2	MOLD IN 3J.OEB01.001
4	NUT INSERT M4x4.8L BRASS	1	MOLD IN 3J.OEB01.001
5	MESH LOWER CASE SECC VG31	1	
6	RUBBER PAD REAR FOOT W100	1	
7	FOOT REAR ADJUST W100	1	
8	NUT HEX+WASHER M3x2.3H NI	1	1.ASSEMBLY WITH 4G.JIS05.001 2.AFTER ASSEMBLY WITH 4G.JIS05.001, USES GULE TO FIX THE NUT
9	BRACKET K-LOCK SECC MP610	1	HEAT MELT WITH 3J.OEB01.001
10	MYLAR MESH LOWER CASE PC VG31	4	HEAT MELT WITH 3J.OEB01.001

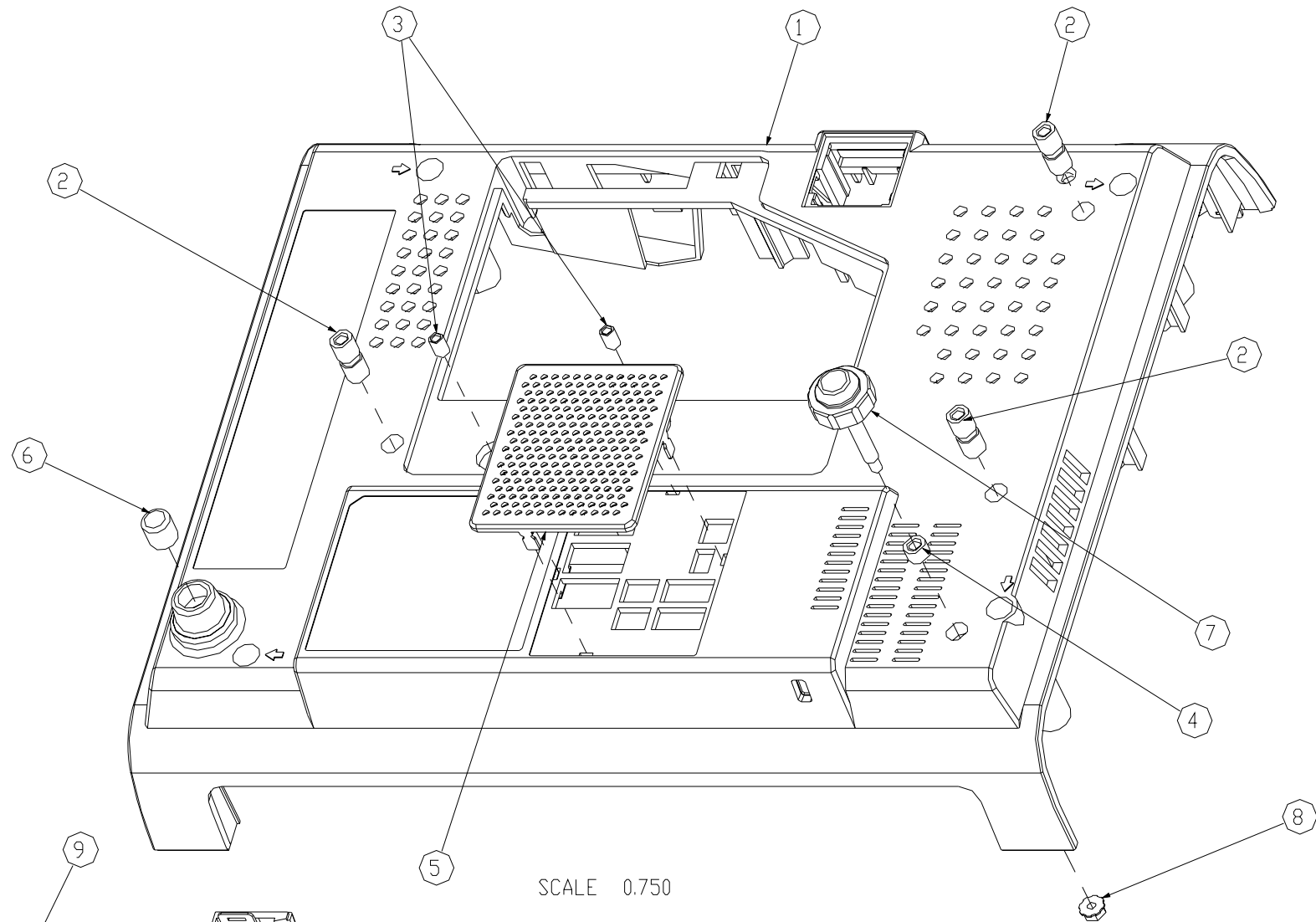

SCALE 0.750

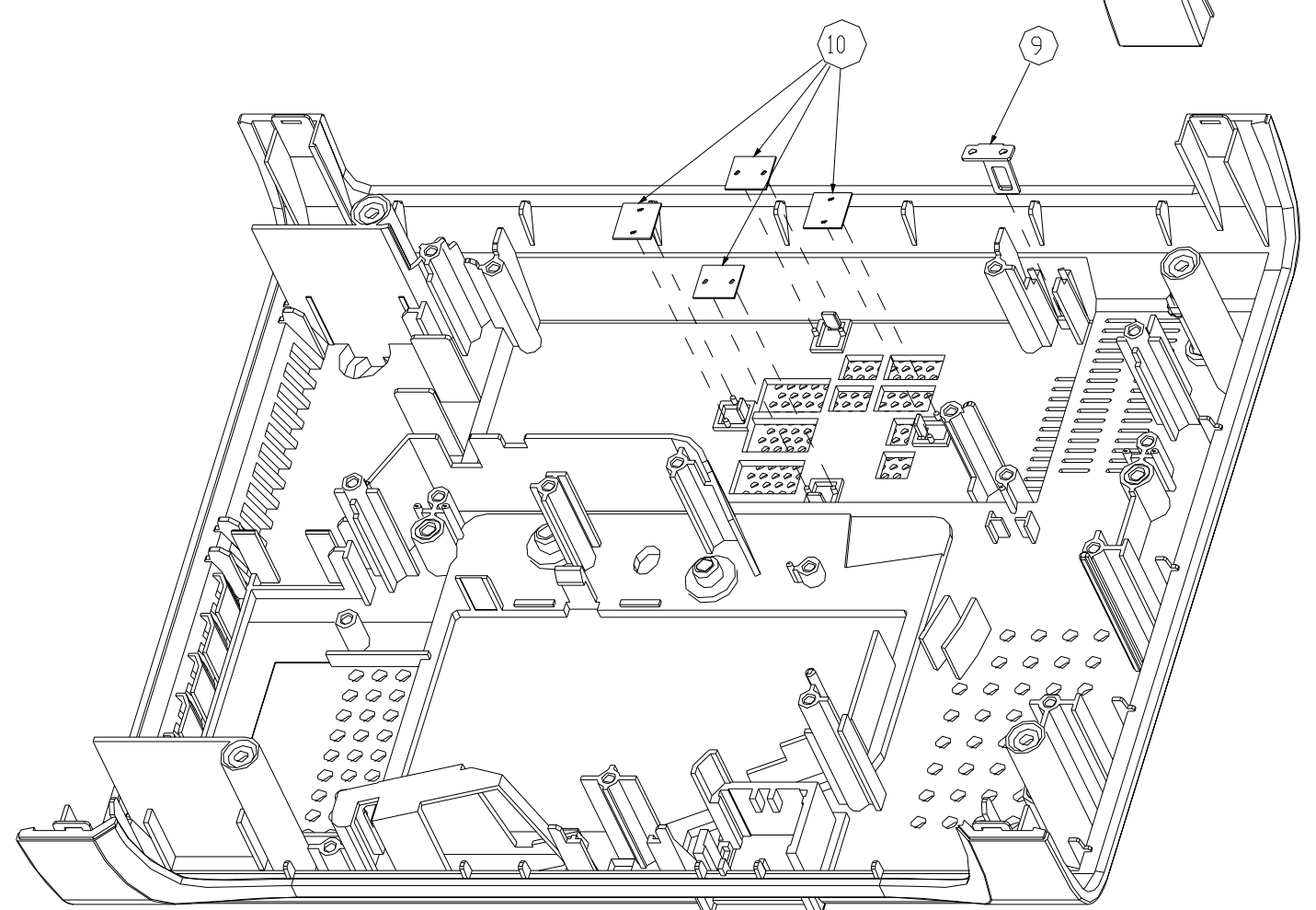

**Module 4 –ASSY FRONT CASE**

ITEM	DESCRIPTION	Q'TY	REMARK
1	COVER FRONT PC+ABS WHT PJ513D	1	
2	LENS IR FRONT PC WHITE VG30	1	
3	MYLAR IR COVER PC VG30	1	HEAT MELT WITH 3J.03A05.031
4	STICKER LOGO VIEWSONIC	1	

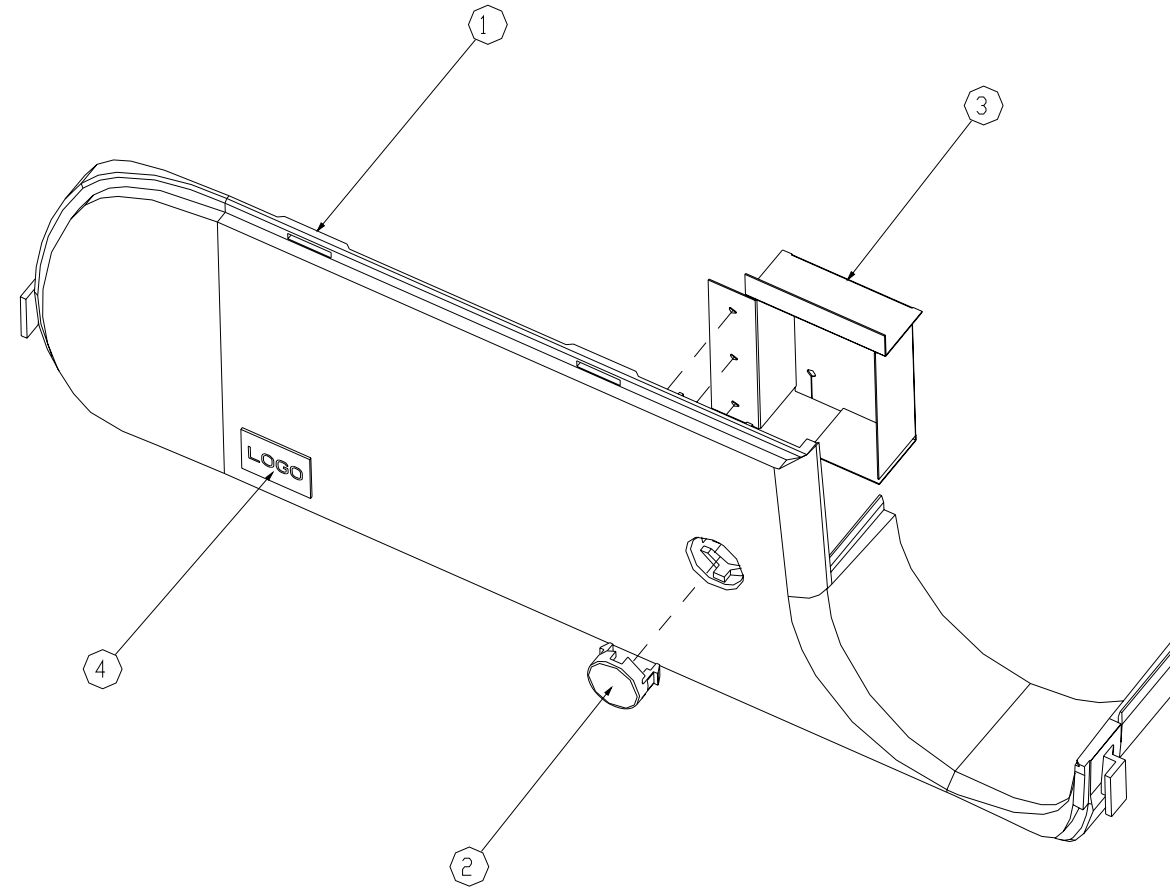

**Module 5 –ASSY REAR CASE**

ITEM	PART NO.	DESCRIPTION	Q'TY	REMARK
1	3J.0CY01.001	COVER REAR PC+ABS PJ513D	1	
2	8G.00031.3R0	NUT INSERT M3x3L D4 BRASS	2	MOLD IN

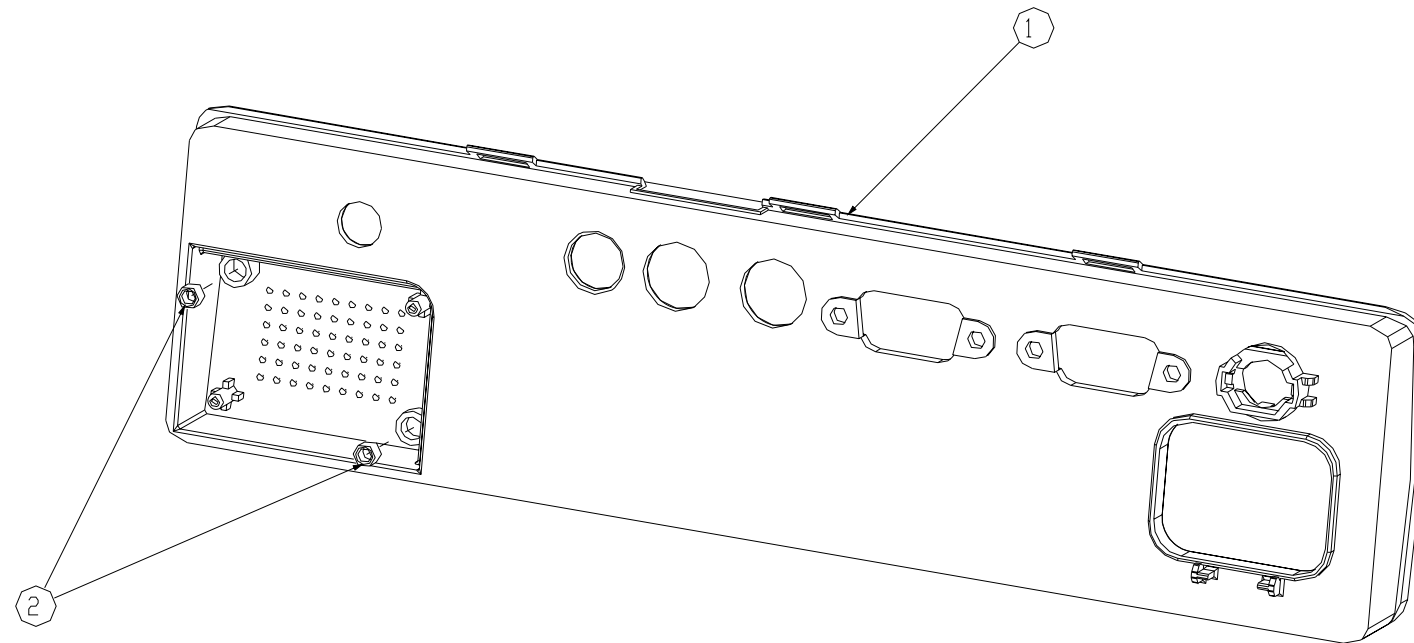

SCALE 1.000

For Worldwide:

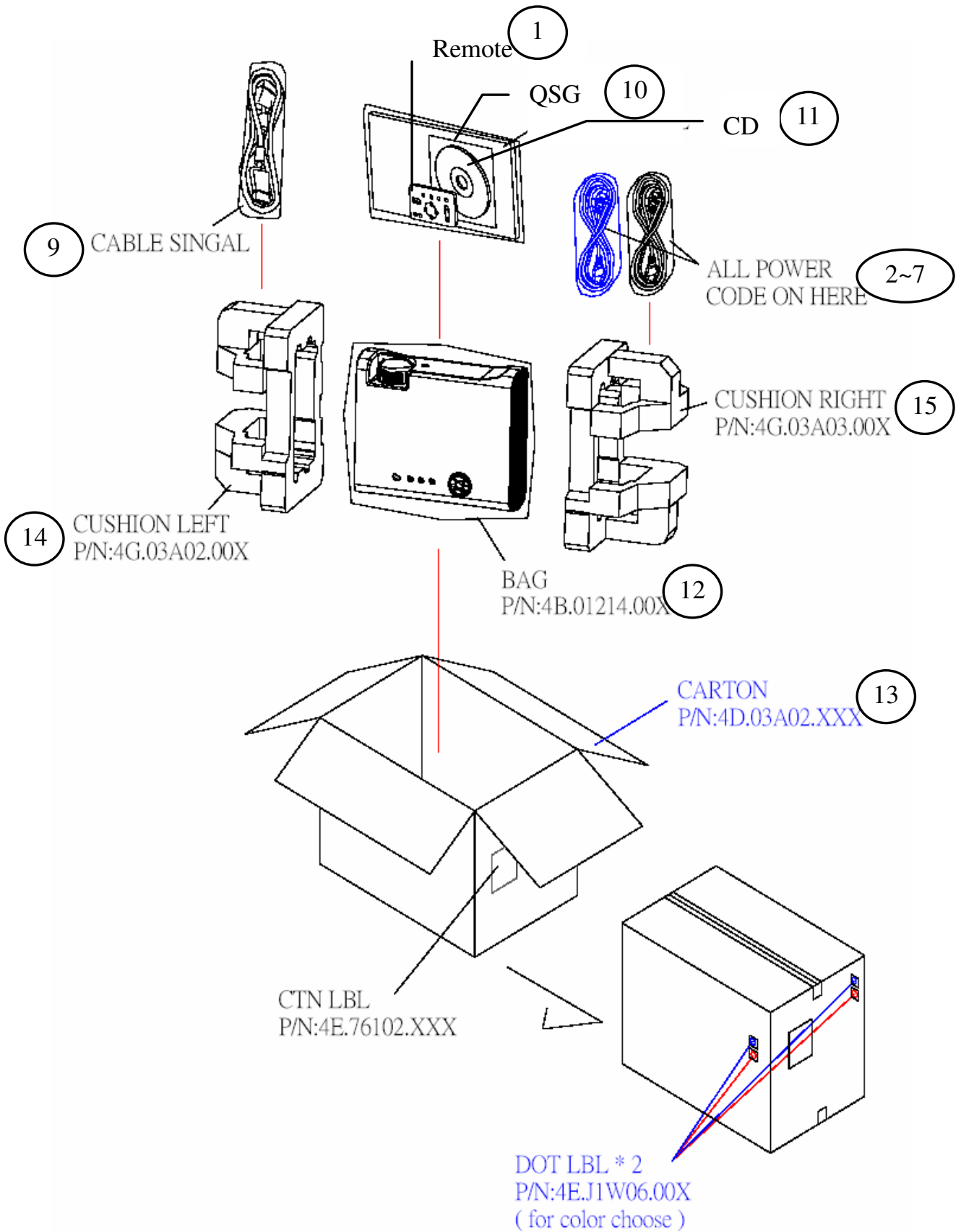

**For China:**

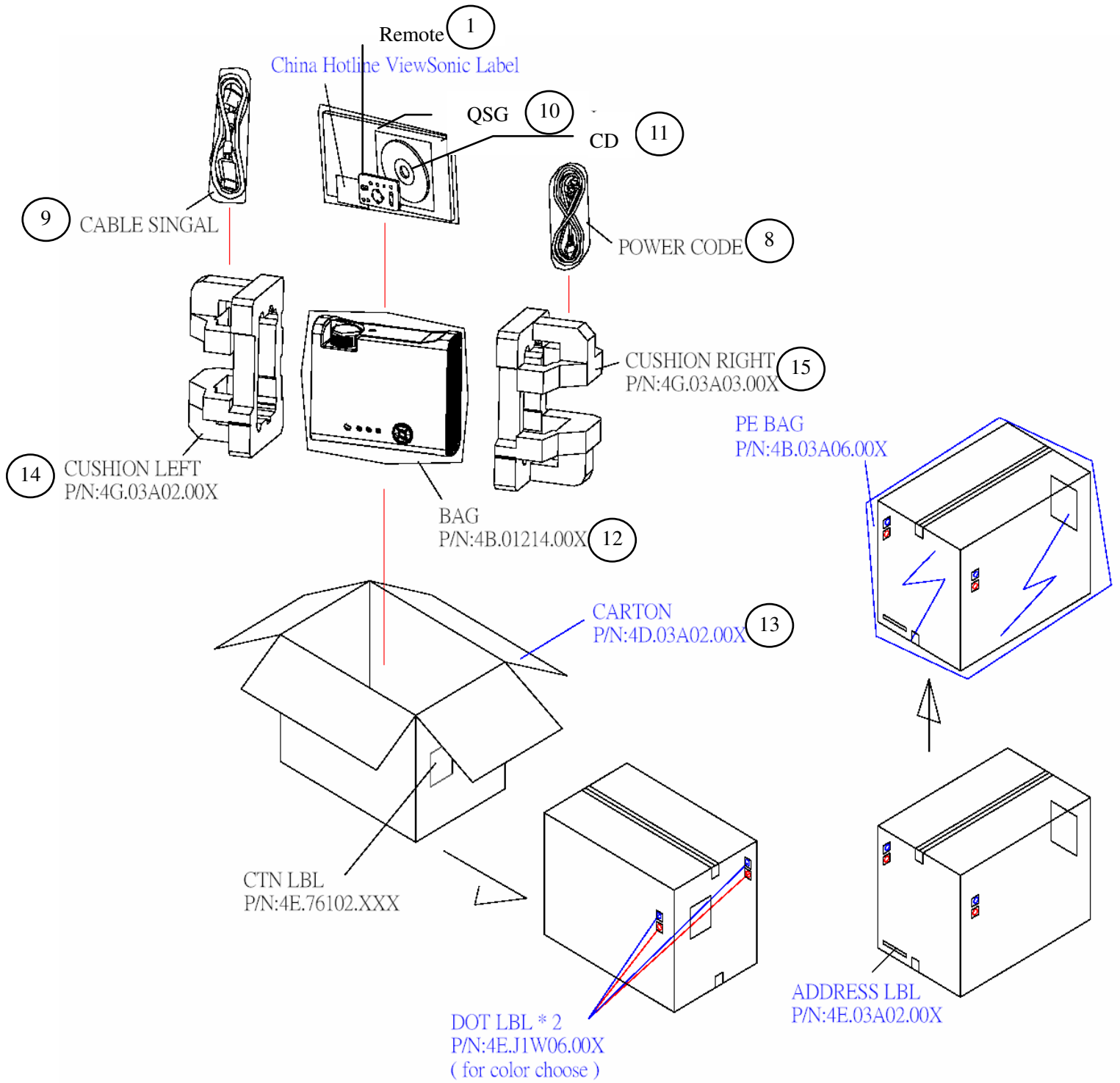

## PACKING PART LIST (PJ513D-1)

**ViewSonic Model Number: VS11959**

**Rev: 1a**

Item	ViewSonic P/N	Ref. P/N	Location	Q'ty
1	A-00008249	5F.26J1K.121	REMOTE RC-7092A-01-0003 PJ513D	1
2	A-00008250	2G.01111.001	CORD SVT125V WO/SH US 1.8M I-S	1
3	A-00008097	2G.82718.281	CORD H05VV-F 10A250V EUR BLK	1
4	A-00008098	2G.01018.000	CORD H05VV-F13A250V 1830MM UK	1
5	A-00008099	2G.01343.001	CORD 3ASL/75DU-IN 250V1.8M AUS	1
6	A-00008193	2G.04321.001	CORD H05VV 250V 1.8M BLK KOR	1
7	A-00008251	2G.01433.001	CORD H05VV 16A 250V 1.5M S-ARF	1
8	A-00008100	2G.04245.001	CORD RVV 250V 1.8M BLK CHINA	1
9	CB-00008120	5K.01207.501	CABLE SIGNAL 15/15P 1.8M+PEBAG	1
10	DC-00008708	4J.0EB01.001	GUIDE QS PJ513D	1
11	DC-00008747	5B.0EB01.002	CD USER MANUAL PJ513D	1
12	P-00008300	4B.01214.001	BAG HDPE+LDPE 415*365*0.4	1
13	P-00008790	4D.03A02.021	CTN AB VIEWSONIC/ PJ513D	1
14	P-00008302	4G.03A02.001	CUSHION LEFT EPE VG30	1
15	P-00008303	4G.03A03.001	CUSHION RIGHT EPE VG30	1

# 11. Recommended Spare Parts List

## RECOMMENDED SPARE PARTS LIST (PJ513D-1)

ViewSonic Model Number: VS11959

Rev.: 1a

Serial No. Prefix: QTY

Item	Description	ECR/ECN	ViewSonic P/N	Ref. P/N	Location	Universal number#
1	<b>Accessories:</b> [Adapter, Remote Control;Power Cord]		Remote Control - 7092A-01-0003	A-00008249	5F.26J1K.121	
2			Replacement Lamp	RLC-035	5J.0EB01.001	
3			Cord/ Cable-125V WO/SH 1.8M US	A-00008250	2G.01111.001	
4			Cord/Cable 250V Black EUR	A-00008097	2G.82718.281	
5			Cord/Cable 1830MM UK	A-00008098	2G.01018.000	
6			Cord/Cable - 250V 1.8M AUS	A-00008099	2G.01343.001	
7			Cord/Cable 250V 1.8M Black CHINA	A-00008100	2G.04245.001	
8			Cord/Cable 250V 1.8M Black KOR	A-00008193	2G.04321.001	
9			Cord/Cable 250V 1.5M S. AFR	A-00008251	2G.01433.001	
10	<b>PC Board Assembly: [All PCBA]</b>		PSU - Supply Board MI MP511+	B-00008774	5E.08040.011	
11			Main Board MI 8L	B-00008775	5E.0EB01.001	
12			Sub Board- CHIP BD MP612 MI	B-00008776	5E.06023.001	
13			Sub Board (Ballast 180W 2.5KV)	B-00008777	5D.0CY12.001	
14	<b>Cabinets: [Front Panel, All Covers, Base Assembly]</b>		Upper Case Assy	C-00008740	6K.0EB06.001	
15			Upper Case Assy, Black	C-00008741	6K.0EB06.011	
16			Lower Case Assy	C-00008742	6K.0EB07.001	
17			Lower Case Assy, Black	C-00008743	6K.0EB07.011	
18			Front Cover	C-00008744	6K.0EB08.001	
19			Front Cover Black	C-00008745	6K.0EB08.011	
20			Back Cover	C-00008746	6K.0EB09.001	
21			Back Cover, Black	C-00008747	6K.0EB09.011	
22			Cover - (Sub Lamp Door) - MP510	C-00008291	6K.01222.001	
23			Cover - (Sub Lamp Door), Black	C-00008748	6K.0EB12.011	
24	<b>Cables: [All Cables]</b>		Signal Cable 15/15P 1.8M, +PE Bag	CB-00008120	5K.01207.501	
25	<b>Documentation: [Quick Start Guide,]</b>		Quick Start Guide	DC-00008708	4J.0EB01.001	
26			CD-Rom	DC-00008709	5B.0EB01.001	
27	<b>Electronic Components: [CRT-EEPROM, Fly Back]</b>		Pack CW Module	E-00008707	CS.5J080.001	
28			Pack LP Module	E-00008708	CS.5J080.011	
29			Integrated Circuit DMD 0.55 SVGA	E-00008709	7A.08060.D00	
30	<b>Miscellaneous: [Switch, Fan, Logo]</b>		Fan *2 70*80*25 30MM	M-00008164	2C.10130.051	
31			Fan 50*50*20 200MM	M-00008165	2C.10139.031	
32			ZOOM Assy, MP612 AOCI	M-00008166	6E.06001.001	
33	<b>Packing Material: [Box, Foam, Bags]</b>		Bag	P-00008300	4B.01214.001	
34			Carton	P-00008790	4D.03A02.021	
35			Left Foam	P-00008302	4G.03A02.001	
36			Right Foam	P-00008303	4G.03A03.001	

Remark 1: Above listed items are examples, supplier can expand the rows to add more necessary items.

Remark 2: All revised RSPLs with newly added items or any change made should be highlighted and correlated with the ECN/ECR approved by ViewSonic Corporation. This is to eliminate repeated cross checks of each item



## \* *Reader's Response* \*

Dear Readers:

Thank you in advance for your feedback on our Service Manual, which allows continuous improvement of our products. We would appreciate your completion of the Assessment Matrix below, for return to ViewSonic Corporation.

### Assessment

**A.** What do you think about the content of this Service Manual?

<i>Unit</i>	<i>Excellent</i>	<i>Good</i>	<i>Fair</i>	<i>Bad</i>
<b>1. Precautions and Safety Notices</b>				
<b>2. Specification</b>				
<b>3. Front Panel Function Control Description</b>				
<b>4. Circuit Description</b>				
<b>5. Adjustment Procedure</b>				
<b>6. Troubleshooting Flow Chart</b>				
<b>7. Block Diagrams</b>				
<b>8. Schematic Diagrams</b>				
<b>9. PCB Layout Diagrams</b>				
<b>10. Exploded Diagram and Exploded Parts List</b>				
<b>11. Recommended Spare Parts List</b>				

**B.** Are you satisfied with this Service Manual?

<i>Item</i>	<i>Excellent</i>	<i>Good</i>	<i>Fair</i>	<i>Bad</i>
<b>1. Service Manual Content</b>				
<b>2. Service Manual Layout</b>				
<b>3. The form and listing</b>				

**C.** Do you have any other opinions or suggestions regarding this service manual?

### Reader's basic data:

<b>Name:</b>		<b>Title:</b>	
<b>Company:</b>			
<b>Add:</b>			
<b>Tel:</b>		<b>Fax:</b>	
<b>E-mail:</b>			

After completing this form, please return it to ViewSonic Quality Assurance in the USA at facsimile 1-909-839-7943. You may also e-mail any suggestions to the Director, Quality Systems & Processes (marc.maupin@viewsonic.com)