

Service Manual

ViewSonic VX2835wm-1

Model No. VS11531

28" wide Color TFT LCD Display

(VX2835wm-1_SM Rev. 1b Jun.2007)

ViewSonic 381 Brea Canyon Road, Walnut, California 91789 USA - (800) 888-8583

Copyright

Copyright © 2007 by ViewSonic Corporation. All rights reserved. No part of this publication may be reproduced, transmitted, transcribed, stored in a retrieval system, or translated into any language or computer language, in any form or by any means, electronic, mechanical, magnetic, optical, chemical, manual or otherwise, without the prior written permission of ViewSonic Corporation.

Disclaimer

ViewSonic makes no representations or warranties, either expressed or implied, with respect to the contents hereof and specifically disclaims any warranty of merchantability or fitness for any particular purpose. Further, ViewSonic reserves the right to revise this publication and to make changes from time to time in the contents hereof without obligation of ViewSonic to notify any person of such revision or changes.

Trademarks

Optiquest is a registered trademark of ViewSonic Corporation.

ViewSonic is a registered trademark of ViewSonic Corporation.

All other trademarks used within this document are the property of their respective owners.

Product disposal at end of product life

The lamp in this product contains mercury. Please dispose of in accordance with local, state or federal laws.

Revision History

Revision	SM Editing Date	ECR Number	Description of Changes	Editor
1a	5/21/2007		Initial Release	Jamie Chang
1b	6/25/2007		Replaced the photo of Step 2 in Section DDCKey	Jamie Chang

TABLE OF CONTENTS

1. Precautions and Safety Notices	1
2. Specification	5
3. Front Panel Function Control Description	35
4. Circuit Description	40
5. Adjusting Procedure	41
6. Trouble Shooting Flow Chart	62
7. Block Diagrams	68
8. Schematic Diagrams	69
9. PCB Layout Diagrams	81
10. Exploded Diagram And Spare Parts List.....	90
11. Recommended Spare Parts List	92

1. Precautions and Safety Notices

1. Appropriate Operation

- (1) Turn off the product before cleaning.
- (2) Use only a dry soft cloth when cleaning the LCD panel surface.
- (3) Use a soft cloth soaked with mild detergent to clean the display housing.
- (4) Disconnect the power plug from AC outlet if the product is not used for a long period of time.
- (5) If smoke, abnormal noise, or strange odor is present, immediately switch the LCD display off.
- (6) Do not touch the LCD panel surface with sharp or hard objects.
- (7) Do not place heavy objects on the LCD display, video cable, or power cord.
- (8) Do not use abrasive cleaners, waxes or solvents for your cleaning.
- (9) Do not operate the product under the following conditions:
 - Extremely hot, cold or humid environment.
 - Areas susceptible to excessive dust and dirt.
 - Near any appliance generating a strong magnetic field.
 - Place in direct sunlight.

2. Caution

No modification of any circuit should be attempted. Service work should only be performed after you are thoroughly familiar with all of the following safety checks and servicing guidelines.

3. Safety Check

Care should be taken while servicing this LCD display. Because of the high voltage used in the inverter circuit, the voltage is exposed in such areas as the associated transformer circuits.

4. Power Supply Requirements

The external AC power operating range shall be from 90 to 264Vac

5. LCD Module Handling Precautions

5.1. Handling Precautions

- (1) Since front polarizer is easily damaged, pay attention not to scratch it.
- (2) Be sure to turn off power supply when inserting or disconnecting from input connector.
- (3) Wipe off water drop immediately. Long contact with water may cause discoloration or spots.
- (4) When the panel surface is soiled, wipe it with absorbent cotton or other soft cloth.
- (5) Since the panel is made of glass, it may break or crack if dropped or bumped on hard surface.
- (6) Since CMOS LSI is used in this module, take care of static electricity and insure human earth when handling.
- (7) Do not open nor modify the Module Assembly.
- (8) Do not press the reflector sheet at the back of the module to any directions.
- (9) In case if a Module has to be put back into the packing container slot after once it was taken out from the container, do not press the center of the CCFL Reflector edge. Instead, press at the far ends of the CFL Reflector edge softly. Otherwise the TFT Module may be damaged.
- (10) At the insertion or removal of the Signal Interface Connector, be sure not to rotate nor tilt

- the Interface Connector of the TFT Module.
- (11) After installation of the TFT Module into an enclosure (LCD monitor housing, for example), do not twist nor bend the TFT Module even momentarily. At designing the enclosure, it should be taken into consideration that no bending/twisting forces are applied to the TFT Module from outside. Otherwise the TFT Module may be damaged.
 - (12) Cold cathode fluorescent lamp in LCD contains a small amount of mercury. Please follow local ordinances or regulations for disposal.
 - (13) Small amount of materials having no flammability grade is used in the LCD module. The LCD module should be supplied by power complied with requirements of Limited Power Source, or be applied exemption.
 - (14) The LCD module is designed so that the CFL in it is supplied by Limited Current Circuit. Do not connect the CFL in Hazardous Voltage Circuit.

5.2 handling and placing procedure

1. Open the carton box, before you remove anything from the carton box, check all the accessory listed in the packing list.

Remember the position of the left and right poly foams to avoid any problem when packing them.



2. When removing the LCD monitor, make sure that you are holding from the back side of the LCD monitor and not the front side of the LCD monitor.



3. Place the LCD monitor on a flat table and remove the plastic bag.



4. When placing the LCD screen on the table, you need to make sure there are no object underneath to avoid any damage on the LCD screen.

It is not advisable to wear any jewelry like rings, bracelet or watch to avoid any scratch on the LCD screen, or casing when doing the service.

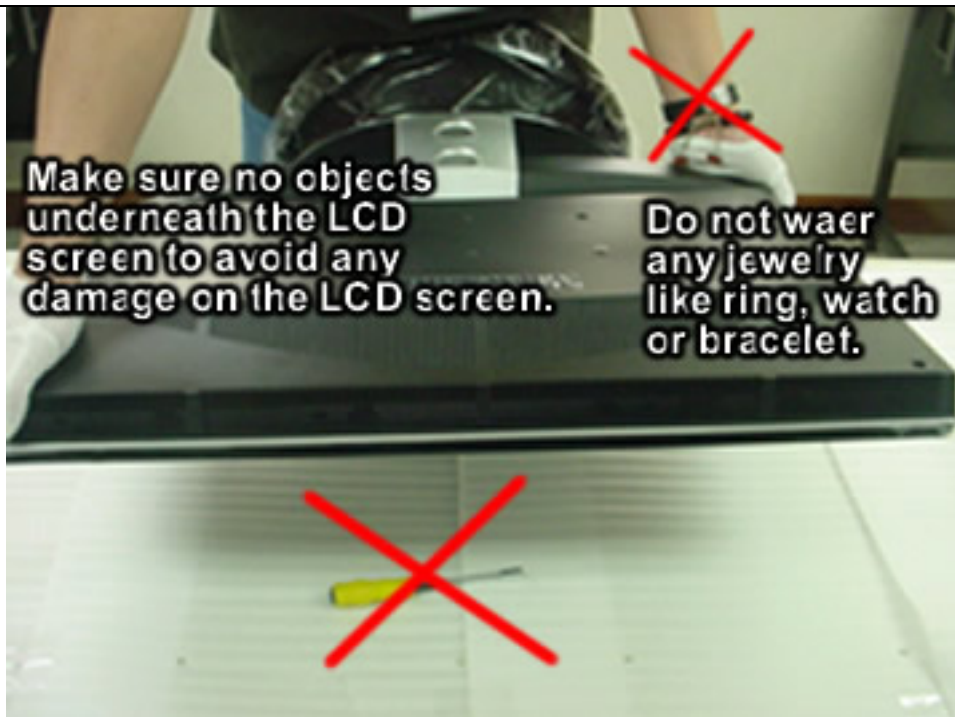

2. Specification

Introduction

FEATURES		VX2835wm
TFTLCD PANEL 1 st	Size	27.54 " wide
	Luminance (Typ)	500 cd/m ²
	Contrast Ratio (Typ)	800:1
	Colors	16.7 M
	Response Time	5 ms(on/off) / 3ms (G to G)
	Viewing Angle (H/V)	160 ° / 160 °
	Recommend resolution	1920x1200@60Hz
Input Signal	Analog	Yes (75ohms, 0.7/1.0 Vp-p)
	Digital	Yes
Sync Compatibility	Separate Sync	Yes
	Composite Sync	Yes(No Guarantee image Quality)
	Sync on Green	Yes(No Guarantee image Quality)
Compatibility	PC	Yes
	Power Mac	Yes
	TV Box	Yes
Power Voltage	AC 100-240V, 50/60Hz	Yes
Power Consumption	On Mode (Max. for Energy star)	< 64.5W
	Off Mode (Max)	≤ 1 W
Audio	3W / THD 10% (Max)	Yes
Ergonomics	Tilt (20 ° - -5 °)	Yes
	Swivel	No
	Pivot	No
	Height Adjust	No
OSD Control	[1] [2] [⏪] [⏩] [▲] [▼]	Yes
Operating Condition	Temperature (°F/°C)	32°F-104°F/+0°C-+40°C
	Humidity (%)	10 % - 90 %
Storage Condition	Temperature (°F/°C)	-4°F-140°F/-20°C-60°C
	Humidity (%)	10 % - 80 %
Regulation	Global: CB, TCO06,WEEE,ROHS VSA:UL, cUL, FCC-B, IRAM, NOM, Energy Star, ICES-003 VSE:,NEMKO/ERGO, CE GOST-R+Hygienic ,SASO , ENERGY, UkrSEPRO VSI: BSMI, PSB, C-TICK, EK , VCCI, VSCN:CCC	

Product definition and specification

Region	VSA	VSAP	VSE	VSCN
	(M)	(A)/(P)/(J)/(S)/(K)	(E)/(U)	(G)
Product Name	VX2835wm			
Model Number	VS11531			
OSD Languages	English, French, German, Italian, Spanish, Finnish, Russian, Japanese, Traditional Chinese, Simplified Chinese			
TFT LCD Panel and Model #	HSD 280MUW1-A			
Scalar	Mstar, Model # :MST 6251DA-205LF			
Input Signal	D-Sub / HDMI / YPbPr / CVBS / S-Video			
Sync Compatibility	Separate / [Composite / SOG(image quality no guarantee)]			
Audio	3W			
Power Consumption	Built-in/ under 64.5W (max , Energy Star Standard@175nits) / 130 W(max @500nits)			
Power Cable	Refer to Appendix G			
Analog Cable (1.8 m, color : black), with PC 2001 and Hot Plug Detect &DDC	YES			
HDMI to DVI-D converter(cablex1.8m)	YES			
ViewSonic CD Wizard	Arabic, English, Finnish, Spanish, German, Italian, Japanese, Swedish, Polish, Korean, Portuguese, Russian, French, Simplified Chinese, Traditional Chinese, Czech, Hungarian, Greek, Dutch, Turkish			
ViewSonic Quick Start Guide				
Screen Protector Mylar	YES			
Extrme Label (?ms)	NO	NO	NO	NO
Service Insert (new version)	YES	NO	NO	NO
Warranty Sticker	NO	NO	NO	YES
Warranty Card	NO	NO	NO	YES
Carton Sticker	NO	NO	NO	YES
PE bag of Carton	NO	NO	NO	YES
Energy Star Sticker(Upper Right corner)	YES	YES	YES	YES
Hi-pot label (Back cover)	YES	YES	YES	YES
QC pass label(Back cover)	NO	NO	NO	YES

4-1 GENERAL specification

Test Resolution & Frequency	1920x1200 @ 60Hz
Test Image Size	Full Size
Contrast and Brightness Controls	Factory Default: Contrast = 70%, Brightness = 100%

4-2 VIDEO INTERFACE

Analog Input Connector	DB-15 (Analog), refer the appendix A			
Digital Input Connector	HDMI, 19pin Tape A			
Video Input 1	RCA jack (Red, Blue, Green) for YPbPr			
Video Input 2	RCA jack (Yellow) for CVBS			
Video Input 3	S-Video jack			
Audio input 1	3.5Mini Jack for PC Audio and (DVI-D adapter applied)			
Audio input 2	RCA jack (White / Red) for YPbPr			
Audio input 3	RCA jack (White / Red) for CVBS and S-Video, they will share the same RCA jack			
Default Input Connector	Defaults to the first detected input			
Video Cable Strain Relief	D-Sub: 12Kg, 5min. HDMI to DVI : 3Kg, 5min. Composite(AV): 3Kg, 5min.			
Video Cable Connector DB-15 Pin out	Compliant DDC / CI			
Video Signals	1. Video RGB (Analog) Separate,[Composite, and Sync on Green (image quality no guarantee)] 2. TMDS (Digital) (Need RCA to SCART for european market)			
Video Impedance	75 Ohms (Analog), 100 Ohms (Digital)			
Maximum PC Video Signal	950 mV with no damage to monitor			
Maximum Mac Video Signal	1250 mV with no damage to monitor			
Sync Signals	TTL			
DDC/CI	Compliant with Revision 1.0			
HDCP	HDCP code inside and compatible			
Sync Compatibility	Separate Sync, [Composite Sync, SOG (image quality no guarantee)]			
Video Compatibility	Shall be compatible with all PC type computers, Macintosh computers, and after market video cards			
Video timing support (CVBS / S-Video)	480i / 480p @ 60Hz 576i / 576p @ 50Hz			
Video timing support (HDMI / YPbPr)	480i / 480p @ 60Hz		576i / 576p @ 50Hz	
	720p @ 50/60Hz		1080i / 1080p @ 50/60Hz	
Resolution Compatibility	640x350	640x400	640x480	720x400

	720x480	800x600	832x624	1024x768			
	1152x864	1152x870	1280x720	1280x768			
	1280x960	1280x1024	1360x768	1400x1050			
	1440x900	1600x1200	1680x1050	1920x1200			
	The image vertical size might not be full screen. But the image vertical position should be at the center.						
Exclusions		Not compatible with interlaced video					
Audio / Video Action		Video input					
		CVBS	S-Video	YPbPr	D-sub	DVI-D via HDMI	HDMI
Audio input	RCA (white + red) with CVBS	●	●	X	X	X	X
	RCA (white + red) with YPbPr	X	X	●	X	X	X
	3.5mm phone jack	X	X	X	●	●	X
	Audio in HDMI	X	X	X	X	X	●

Video OVERSCAN

Component over scan: 5~8%

AV over scan: 5~8%

HDMI over scan: No over scan for PC input, 5~8% for video source.

PC: No over scan

4-3 POWER SUPPLY

Internal Power Supply	Part Number: 71-Y2831200G001
Input Voltage Range	AC90~264 (Worldwide)
Input Frequency Range	47 to 64 Hertz
Short Circuit Protection	Output can be shorted without damage
Over Current Protection	3.3~4.5A typ. at 5 VDC (Protect when short circuit)
Leakage Current	3.5mA (Max) at 264VAC / 50Hz
Efficiency	80 % typical at 115VAC Full Load
Fuse	Internal and not user replaceable
Power Dissipation	< 130 Watts (typ)
Max Input AC Current	1.6A (max)
Inrush Current (Cold Start)	80 A Max./ 240VAC / 50Hz (Cold Start at 25°C, Full Load)
Power Supply Cold Start	Shall start and function properly when under full load, with all combinations of input voltage, input frequency, and operating temperature
Power Supply Transient Immunity	Shall be able to withstand an ANSI/IEEE C62.41-1980 6000V 200 ampere ring wave transient test with no damage

Power Supply Line Surge Immunity	Shall be able to withstand 1.5 times nominal line voltage for one cycle with no damage
Power Supply Missing Cycle Immunity	Shall be able to function properly, without reset or visible screen artifacts, when ½ cycle of AC power is randomly missing at nominal input
Power Supply Acoustics	The power supply shall not produce audible noise that would be detectable by the user. Audible shall define to be in compliance with ISO 7779 (DIN EN27779:1991) Noise measurements of machines acoustics. Power Switch noise shall not be considered
US Type Power Cable Color = Black	Separate 3-prong NEMA 5-15P type plug. Length = 1.8m. Connects to display.
European Type Power Cable Color = Black	Schuko CEE7-7 type plug. Length = 1.8m, Connects to display.
CCC Type Power Cable Color = Black	Separate 3-prong type plug. Length = 1.8m. Connects to display.
PSE Type Power Cable Color = Black	Separate 2-prong NEMA 1-15P type plug. Length = 1.8m. Connects to display.
Power Saving Operation(Method)	VESA DPMS Signaling
Power Consumption	On Mode <60 W (Typ) / under 64W (Max for Energy Star) Max power output :130W(Max. @500nits) Saving Mode < 2 W@230VAC 50Hz Off Mode < 1 W @230VAC 50Hz (DC Power Off; Meet to Energy Star Ver4.0 Tier2)
Recovery Time	On Mode = N/A, Active Off < 3 sec

4-4 ELECTRICAL REQUIREMENT

Horizontal / Vertical Frequency

Horizontal Frequency	24 – 82 kHz
Vertical Refresh Rate	50 – 85* Hz
Maximum Pixel Clock	Analog is 205MHz, Digital is 165 MHz
Sync Polarity	Independent of sync polarity.

Timing Table

Item	Timing	Analog			Digital - TMDS	YPbPr	CVBS	S-Video	Remark
		Separated	Composite	SOG					
1	640 x 350 @ 70 Hz, 32 KHz	✓	✓	✓	✓	X	X	X	For Composite and SOG, the image vertical size image will be not full screen (Still at the center), And the OSD will be 640x350/640x400/720x400 (promary= 640x400).
2	640 x 350 @ 85 Hz, 38 KHz	✓	✓	✓	✓	X	X	X	For Composite and SOG, the image vertical size image will be not full screen (Still at the center), And the OSD will be 640x350/640x400/720x400 (promary= 640x400).
3	640 x 400 @ 60 Hz, 32 KHz	✓	✓	✓	✓	X	X	X	For SOG sync, switch 640x400@60Hz and 640x480@60Hz by [1]+[2] short cut key (primary = 640x480@60Hz)
4	640 x 400 @ 70 Hz, 32 KHz	✓	✓	✓	✓	X	X	X	For Composite and SOG, the image vertical size image will be not full screen (Still at the center), And the OSD will be 640x350/640x400/720x400 (promary= 640x400).
5	640 x 400 @ 85 Hz, 38 KHz	✓	✓	✓	✓	X	X	X	For Composite and SOG, the image vertical size image will be not full screen (Still at the center), And the OSD will be 640x350/640x400/720x400 (promary= 640x400).

6	640 x 480 @ 50 Hz, 25 KHz	✓	✓	✓	✓	X	X	X	
7	640 x 480 @ 60 Hz, 32 KHz	✓	✓	✓	✓	X	X	X	For SOG sync, switch 640x400@60Hz and 640x480@60Hz by [1]+[2] short cut key (primary = 640x480@60Hz)
8	640 x 480 @ 67 Hz, 35 KHz	✓	✓	✓	✓	X	X	X	Mac Timing
9	640 x 480 @ 70 Hz, 35 KHz	✓	✓	✓	✓	X	X	X	
10	640 x 480 @ 72 Hz 38 KHz	✓	✓	✓	✓	X	X	X	
11	640 x 480 @ 75 Hz, 38 KHz	✓	✓	✓	✓	X	X	X	
12	640 x 480 @ 85 Hz, 43 KHz	✓	✓	✓	✓	X	X	X	
13	720 x 400 @ 70 Hz, 32 KHz	✓	✓	✓	✓	X	X	X	For Composite and SOG, the image vertical size image will be not full screen (Still at the center), And the OSD will be 640x350/640x400/720x400 (promary= 640x400).
14	720 x 400 @ 85 Hz, 38 KHz	✓	✓	✓	✓	X	X	X	For Composite and SOG, the image vertical size image will be not full screen (Still at the center), And the OSD will be 640x350/640x400/720x400 (promary= 640x400).
15	720 x 480 @ 60 Hz, 32 KHz	✓	✓	✓	✓	X	X	X	For Analog sync, the information OSD shows 640x480
16	800 x 600 @ 60 Hz, 38 KHz	✓	✓	✓	✓	X	X	X	
17	800 x 600 @ 70 Hz, 43 KHz	✓	✓	✓	✓	X	X	X	
18	800 x 600 @ 72 Hz, 48 KHz	✓	✓	✓	✓	X	X	X	
19	800 x 600 @ 75 Hz, 47 KHz	✓	✓	✓	✓	X	X	X	
20	800 x 600 @ 85 Hz, 54 KHz	✓	✓	✓	✓	X	X	X	
21	832 x 624 @ 75 Hz, 50 KHz	✓	✓	✓	✓	X	X	X	
22	1024 x 768 @ 50 Hz, 40 KHz	✓	✓	✓	✓	X	X	X	For Separated and Composite sync, Switch 1024x768@50Hz and 1280x768@50Hz by [1]+[2] short cut key (primery = 1024x768@50Hz)
23	1024 x 768 @ 60 Hz, 48 KHz	✓	✓	✓	✓	X	X	X	
24	1024 x 768 @ 70 Hz, 57 KHz	✓	✓	✓	✓	X	X	X	
25	1024 x 768 @ 72 Hz, 58 KHz	✓	✓	✓	✓	X	X	X	
26	1024 x 768 @ 75 Hz, 60 KHz	✓	✓	✓	✓	X	X	X	
27	1024 x 768 @ 75 Hz, 60 KHz	✓	✓	✓	✓	X	X	X	

28	1024 x 768 @ 85 Hz, 69 KHz	✓	✓	✓	✓	X	X	X	
29	1152 x 864 @ 75 Hz, 68 KHz	✓	✓	✓	✓	X	X	X	
30	1152 x 870 @ 75 Hz, 69 KHz	✓	✓	✓	✓	X	X	X	
31	1280 x 720 @ 50 Hz, 38 KHz	✓	X	X	✓	X	X	X	
32	1280 x 720 @ 60 Hz, 38 KHz	✓	X	X	✓	X	X	X	
33	1280 x 768 @ 50 Hz, 40 KHz	✓	✓	✓	✓	X	X	X	For Separated and Composite sync, Switch 1024x768@50Hz and 1280x768@50Hz by [1]+[2] short cut key (primary = 1024x768@50Hz)
34	1280 x 768 @ 60 Hz, 47 KHz	✓	✓	✓	✓	X	X	X	
35	1280 x 768 @ 60 Hz, 48 KHz	✓	✓	✓	✓	X	X	X	
36	1280 x 768 @ 75 Hz, 60 KHz	✓	✓	✓	✓	X	X	X	
37	1280 x 768 @ 85 Hz, 69 KHz	✓	✓	✓	✓	X	X	X	
38	1280 x 960 @ 50 Hz, 49 KHz	✓	✓	✓	✓	X	X	X	
39	1280 x 960 @ 60 Hz, 60 KHz	✓	✓	✓	✓	X	X	X	
40	1280 x 960 @ 75 Hz, 75 KHz	✓	✓	✓	✓	X	X	X	
41	1280 x 960 @ 85 Hz, 86 KHz	✓	✓	✓	✓	X	X	X	
42	1280 x 1024 @ 50 Hz, 53 KHz	✓	✓	✓	✓	X	X	X	
43	1280 x 1024 @ 60 Hz, 64 KHz	✓	✓	✓	✓	X	X	X	
44	1280 x 1024 @ 70 Hz, 75 KHz	✓	✓	✓	✓	X	X	X	
45	1280 x 1024 @ 75 Hz, 80 KHz	✓	✓	✓	✓	X	X	X	
46	1280 x 1024 @ 85 Hz, 91 KHz	✓	✓	✓	✓	X	X	X	
47	1360 x 768 @ 60 Hz, 48 KHz	✓	✓	✓	✓	X	X	X	
48	1400 x 1050 @ 50 Hz, 54 KHz	✓	✓	✓	✓	X	X	X	
49	1400 x 1050 @ 60 Hz, 65 KHz	✓	✓	X	✓	X	X	X	For analog sync, Switch 1400x1050@60Hz and 1680x1050@60Hz by [1]+[2] short cut key (primary = 1400x1050@60Hz)
50	1400 x 1050 @ 60 Hz, 65 KHz	✓	✓	X	✓	X	X	X	For Separated and Composite sync, Switch 1400x1050@60Hz and 1680x1050@60Hz by [1]+[2] short cut key (primary =

										1400x1050@60Hz)
51	1400 x 1050 @ 75 Hz, 82 KHz	✓	✓	✓	✓	X	X	X		
52	1440 x 900 @ 60 Hz, 56 KHz	✓	✓	✓	✓	X	X	X		
53	1440 x 900 @ 60 Hz, 60 KHz	✓	✓	✓	✓	X	X	X		
54	1440 x 900 @ 75 Hz, 75 KHz	✓	✓	✓	✓	X	X	X		
55	1440 x 900 @ 85 Hz, 85 KHz	✓	✓	✓	✓	X	X	X		
56	1600 x 1200 @ 50 Hz, 62 KHz	✓	✓	✓	✓	X	X	X		
57	1600 x 1200 @ 60 Hz, 75 KHz	✓	✓	✓	✓	X	X	X		
58	1680 x 1050 @ 60 Hz, 65 KHz	✓	✓	X	✓	X	X	X		For analog sync, Switch 1400x1050@60Hz and 1680x1050@60Hz by [1]+[2] short cut key (primary = 1400x1050@60Hz)
59	1680 x 1050 @ 60 Hz, 65 KHz	✓	✓	X	✓	X	X	X		For Separated and Composite sync, Switch 1400x1050@60Hz and 1680x1050@60Hz by [1]+[2] short cut key (primary = 1400x1050@60Hz)
60	1920 x 1200 @ 60 Hz, 74 KHz	✓	✓	✓	✓	X	X	X		Reduce Blanking
61	480p @ 50 Hz	X	X	X	✓	✓	X	X		Unable Test
62	480p @ 60 Hz	X	X	X	✓	✓	X	X		
63	480i @ 50 Hz	X	X	X	✓	✓	✓	✓		Unable Test
64	480i @ 60 Hz	X	X	X	✓	✓	✓	✓		
65	576i @ 50 Hz	X	X	X	✓	✓	X	X		
66	576i @ 60 Hz	X	X	X	✓	✓	X	X		Unable Test
67	576p @ 50 Hz	X	X	X	✓	✓	X	X		
68	576p @ 60 Hz	X	X	X	✓	✓	X	X		Unable Test
69	720p @ 50 Hz	X	X	X	✓	✓	X	X		
70	720p @ 60 Hz	X	X	X	✓	✓	X	X		
71	1080i @ 50 Hz	X	X	X	✓	✓	X	X		
72	1080i @ 60 Hz	X	X	X	✓	✓	X	X		
73	1080p @ 50 Hz	X	X	X	✓	✓	X	X		
74	1080p @ 60 Hz	X	X	X	✓	✓	X	X		

4-5 FRONT PANEL CONTROLS AND INDICATORS

Front Panel Hardware Controls

Power Switch (Front Head)	Power Control, soft Power Switch.
Power LED (Front Head)	Blue – ON Orange – Active Off Dark = Soft Power Switch OFF
Front Panel Controls (Head) [1] [2] [⏻] [▼] [▲]	[1] BUTTON 1 [2] Button 2 [⏻] Power [▼] DOWN ARROW BUTTON [▲] UP ARROW BUTTON Note: Power Button, Button 1 and Button 2 must be one-shot logic operation. (i.e. there should be no cycling)
Reaction Time	OSD must fully appear within 0.5s after pressing Button 1

Short Cuts Function from the button(s)

[1]	Main Menu
[2]	Input toggle (D-sub / HDMI / YPbPr / S-Video / CVBS)
[▼]	To immediately audio menu.
[▼] + [▲]	Contrast & Brightness page (Recall both of audio to default under Audio page)
[1] + [2]	Toggle 720x400 and 640x400 mode when input 720x400 or 640x400 mode
[1] + [▼] + [▲] (Keep pressing 3 sec)	White Balance. (Not shown on user's guide)
[1] + [▼]	Power Lock
[1] + [▲]	OSD Lock
[▲]	Essential mode switch Standard ->Text -> Cinema -> Game -> Portrait -> Scenery -> Vivid
[2] + [▲]	Skin tone switch Nature -> Reddish -> yellowish
[2] + [▼]	DDC/CI ON/Off (ON:DDC/CI ; Off:DDC/2B)
[▼] + [▲] + [⏻]	Factory Mode
Remark : All the short cuts function are only available while OSD off	

Main Menu Controls

<p>Auto Image Adjust^{*1}</p> <p>Contrast/Brightness^{*2*4}</p> <p>Input Select</p> <p>D-Sub,</p> <p>AV (CVBS)</p> <p>S-Video^{*5},</p> <p>YPbPr^{*5}</p> <p>HDMI</p> <p>Audio Adjust</p> <p>Volume^{*4},</p> <p>Mute^{*4}</p> <p>Bass,</p> <p>Treble,</p> <p>Balance,</p> <p>Color Adjust</p> <p>SRGB,</p> <p>9300K,</p> <p>7500K,</p> <p>6500K(default),</p> <p>5400,</p> <p>User Color [R, G, B]</p> <p>Information</p> <p>H Frequency,</p> <p>V Frequency,</p> <p>Resolution,</p> <p>Pixel Clock,</p> <p>Video Format</p> <p>Serial Number,</p> <p>Model Number,</p> <p>www.ViewSonic.com</p>	<p>Manual Image Adjust</p> <p>Horizontal Size^{*1},</p> <p>H/V. Position^{*1},</p> <p>Fine Tune^{*1},</p> <p>Sharpness^{*3},</p> <p>Tint,</p> <p>Color</p> <p>Opticolor [Standard, Text , Cinema, Game, Portrait, Scenery, Vivid]</p> <p>Opticolor Skin Tone[Nature, reddish ,yellowish],</p> <p>Aspect ratio [1:1 / 4:3 / 16:9 / full screen] ,</p> <p>PIP [position 1,2,3,4 / Size 1, 2 / Source1,2],</p> <p>PBP [Source1,2]</p> <p>Setup Menu</p> <p>Language [English, French, German, Italian, Spanish, Finnish, Russian, Japanese, Simplified Chinese, Traditional Chinese]</p> <p>Resolution Notice,</p> <p>OSD Position,</p> <p>OSD Timeout,</p> <p>OSD Background</p> <p>Sleep [30,45,60,120,off]</p> <p>Memory Recall</p>
---	--

*1 These functions are not available in Digital Mode

*2 These functions are not available under SRGB Mode, Opticolor On, and Opticolor Skin Tone On

*3 These functions are not available under Native Resolution Mode

*4 **These functions setting can be recalled to default value under certain page by pressing [▼]+[▲]**

*5 The audio functions should be transfer to RCA type from mini phone jack type when work under YPbPr mode.

*6 The audio functions should be transfer to HDMI type from mini phone jack type (or RCA type) when work under HDMI mode with audio input

[Remark] Please refer to the detail in the Appendix C

Function descriptions

OSD Lock short cuts function for the buttons

The OSD lock will be activated by pressing the front panel control buttons "(1), & (▲)" for 10 seconds.

If the user then tries to access the OSD by pressing any of the buttons "1", "▼", "▲", "2" a message will appear on the screen for 3 seconds showing "OSD Locked".

The OSD lock will be deactivated by pressing the front panel control buttons "(1), & (▲)" again for 10 seconds.

Note1: When the OSD is locked will lock all functions, including "Volume" and "Mute"

Note2: Status bar indicating OSD Lock or Unlock is in progress and when complete it will indicate "OSD Locked"

Note3: OSD Lock should not lock Power Button and Power Lock function

Power Lock short cuts function for the buttons

The power button lock will be activated by pressing the front panel control buttons "(1), & (▼)" for 10 seconds.

Locking the power button means that the user won't be able to turn off the LCD while the power button is locked. If the user presses the power button while it is locked, a message will appear on the screen for 3 seconds showing "Power Button Locked". It also means that with the power button locked, the LCD would automatically turn back "On" when power is restored after a power failure. If the power button is not in the locked mode, then power should return to it's previous state when power is restored after a power failure.

The power button lock will be deactivated by pressing the front panel control buttons "(1), & (▼)" again for 10 seconds.

Note 1: Status bar indicating Power Button lock or unlock is in progress and when complete it will indicate "Power Button Locked"

Note 2: Power should only be lockable in the "On State"

Memory Recall Actions

Memory Recall action on the analog and digital mode as below

1. Set the factory defaults as shown in Section 4-8
2. Clean all the mode setting buffer
3. Execute Auto Image Adjust

Note: Memory Recall should have no effect for Language, Power Lock, User Color Settings or Input Priority

Resolution Notice Actions

1. Resolution Notice OSD should show on screen after changing to non-native mode for 30 sec
2. The OSD should disappear after 10 sec or by pressing button [1] or [2]

Resolution Notice function should be disabled when press button [2] under Resolution Notice OSD

0-Touch™ Function Actions

1. Execute Auto Image Adjust when new mode detected, and save the settings to buffer for further use
2. It should be reset by Memory Recall function
(Should not reset by power off, power unplug and others)

OSD Auto Save

The OSD shall save new settings when it is turned off by the user or when it times out. There shall not be a separate save

Input Priority

This function is defined the auto detect priority when the display has several inputs. Please refer to the detail flow chart as the appendix D

4-6 AUDIO INTERFACE (SPEAKER SPECIFICATION)

Line input signal	1.0 Vrms @1kHz
Maximum Amp power output (Watt)	3 W (RL=8Ω)
Amp –THD	< 10 % THD @1kHz
Speaker Power rating(Ω/Watt)	8Ω/ 3 W
Signal to Noise Ratio	72 dB
Frequency response	300 – 20kHz
SPL.	85 ± 3 dB (at 0.5m)
FO	300 Hz
Line input connection	3.5 mm stereo jacks HDMI RCA 1 (with YPbPr) RCA 2 (with CVBS / S-Video)
Vibration	There should be no audible vibration resonance at volume=100% & any Freq.
Screen image	There should be no affect on the screen image stability under any conditions
Connector PC99 requirement Audio in	Lime Green pantone # 577C
Cable type / length	3.5mm stereo cable / 1.8m length
Audio DPMS	Speakers stay off when the rest of the monitor is in power saving Note: There is no guarantee <1 W at power consumption in Active Off mode, when the Audio Cable is connected

4-7 TFT LCD PANEL

Panel Source Identify

The panel code "T" for HannStar panel should be shown on the position

1. Lower right side of ID label. (See Figure 2)
2. Lower right side of UPC label . (See Figure 3)
3. The F/W version sticker or silkscreen Main board.

Panel Characteristics:

1st Source Panel

Model number	HSD280MUW1-A	
Type	TN type with RSDS interface	
Active Size	27.5" wide; 593.28 (H) x 370.8 (V)	
Pixel Arrangement	RGB Vertical Stripe	
Pixel Pitch	0.309 (H) x 0.309 (H) mm	
Glass Treatment	Anti Glare (Hard coating 3H)	
# of Backlights	14 CCFL w/ Inverter / direct type	
Backlight Life	50000Hours (Min) at 6mA	
Luminance (5-point) – Condition: CT = User Color, Contrast = Max, Brightness = Max	500 cd/m ² (Typ after 30 minute warm up) 400 cd/m ² (Min after 30 minute warm up)	
Brightness Uniformity	≥75% Entire Area (min)	
Contrast Ratio	800:1 (typ), 600:1(min)	
Color Depth	16.7 million colors	
Viewing Angle (Horizontal) TN type	@ CR>10 Typical: 160 Minimum: 150	
Viewing Angle (Vertical) TN type	@ CR>10 Typical: 160 Minimum: 150	
Response Time 10%-90% @ Ta=25°C	Typical = 5ms (on/off) / 3ms (G to G) Maxmum = 10 ms (on/off) / 7ms (G to G)	
Panel Defects	Please see Panel Quality Specifications.	

EDID DATA

VX2835wm-a

Time: 14:26:31

Date: Wed Jan 17, 2007

VIEWSONIC CORPORATION
EDID Version # 1, Revision # 3
DDCTest For: ViewSonic VX2835wm

EDID Block 0, Bytes 0-127

128 BYTES OF EDID CODE:

	0	1	2	3	4	5	6	7	8	9
0	00	FF	FF	FF	FF	FF	FF	00	5A	63
10	1F	0F	01	01	01	01	01	11	01	03
20	6E	3B	25	78	2E	9E	71	A6	54	4C
30	9F	24	10	51	57	BF	EF	80	D1	00
40	B3	00	A9	40	95	00	90	40	81	80
50	81	40	71	4F	28	3C	80	A0	70	B0
60	23	40	30	20	36	00	51	73	21	00
70	00	1A	00	00	00	FF	00	51	46	47
80	30	37	30	31	30	30	30	30	31	0A
90	00	00	00	FD	00	32	4C	1E	52	11
100	00	0A	20	20	20	20	20	20	00	00
110	00	FC	00	56	58	32	38	33	35	77
120	6D	0A	20	20	20	20	00	5F		

- (08-09) ID Manufacturer Name _____ = VSC
- (11-10) Product ID Code _____ = 0F1F
- (12-15) Last 5 Digits of Serial Number _____ = Not Used
- (16) Week of Manufacture _____ = 01
- (17) Year of Manufacture _____ = 2007
- (10-17) Complete Serial Number _____ = See Descriptor Block
- (18) EDID Version Number _____ = 1
- (19) EDID Revision Number _____ = 3
- (20) VIDEO INPUT DEFINITION:
 - Analog Signal
 - 0.700, 0.000 (0.700 Vp-p)
 - Separate Syncs, Composite Sync, Sync on Green

- (21) Maximum Horizontal Image Size _____ = 590 mm
- (22) Maximum Vertical Image Size _____ = 370 mm
- (23) Display Gamma _____ = 2.20
- (24) Power Management and Supported Feature(s):
 Active Off/Very Low Power, Standard Default Color Space,
 Preferred Timing Mode
 Display Type = R/G/B Color
- (25-34) CHROMA INFO:
 Red X - 0.650 Green X - 0.300 Blue X - 0.142 White X - 0.316
 Red Y - 0.329 Green Y - 0.623 Blue Y - 0.065 White Y - 0.341
- (35) ESTABLISHED TIMING I:
 720 X 400 @ 70Hz (IBM,VGA)
 640 X 480 @ 60Hz (IBM,VGA)
 640 X 480 @ 67Hz (Apple,Mac II)
 640 X 480 @ 72Hz (VESA)
 640 X 480 @ 75Hz (VESA)
 800 X 600 @ 56Hz (VESA)
 800 X 600 @ 60Hz (VESA)
- (36) ESTABLISHED TIMING II:
 800 X 600 @ 72Hz (VESA)
 800 X 600 @ 75Hz (VESA)
 832 X 624 @ 75Hz (Apple,Mac II)
 1024 X 768 @ 60Hz (VESA)
 1024 X 768 @ 70Hz (VESA)
 1024 X 768 @ 75Hz (VESA)
 1280 X 1024 @ 75Hz (VESA)
- (37) Manufacturer's Reserved Timing:
 1152 X 870 @ 75Hz (Apple,Mac II)
- (38-53) Standard Timing Identification:
 1920 X 1200 @60Hz
 1680 X 1050 @60Hz
 1600 X 1200 @60Hz
 1440 X 900 @60Hz
 1400 X 1050 @60Hz
 1280 X 1024 @60Hz
 1280 X 960 @60Hz
 1152 X 864 @75Hz

(54-71) Detailed Timing / Descriptor Block 1:

1920x1200 Pixel Clock: 154.00 MHz

Horizontal Image Size: 593 mm

Vertical Image Size: 371 mm

Refreshed Mode: Non-Interlaced Normal Display - No Stereo

Horizontal:

Active Time: 1920 pixels	Blanking Time: 160 pixels
Sync Offset: 48 pixels	Sync Pulse Width: 32 pixels
Border: 0 pixels	Frequency: 74.04 KHz

Vertical:

Active Time: 1200 lines	Blanking Time: 35 lines
Sync Offset: 3 lines	Sync Pulse Width: 6 lines
Border: 0 lines	Frequency: 59.95 Hz

Digital Separate, Horizontal Polarity (+) Vertical Polarity (-)

(72-89) Detailed Timing / Descriptor Block 2:

Monitor Serial Number:
QFG070100001

(90-107) Detailed Timing / Descriptor Block 3:

Monitor Range Limits:
Min Vertical Freq - 50 Hz
Max Vertical Freq - 76 Hz
Min Horiz. Freq - 30 KHz
Max Horiz. Freq - 82 KHz
Pixel Clock - 170 MHz
Secondary GTF - Not Supported

(108-125) Detailed Timing / Descriptor Block 4:

Monitor Name:
VX2835wm

(126) No Extension EDID Block(s)

(127) CheckSum OK

Time: 16:22:30

Date: Wed Jan 17, 2007

VIEWSONIC CORPORATION
EDID Version # 1, Revision # 3
DDCTest For: ViewSonic VX2835wm

EDID Block 0, Bytes 0-127

128 BYTES OF EDID CODE:

	0	1	2	3	4	5	6	7	8	9
0	00	FF	FF	FF	FF	FF	FF	00	5A	63
10	1F	0F	01	01	01	01	01	11	01	03
20	80	3B	25	78	2E	9E	71	A6	54	4C
30	9F	24	10	51	57	BF	EF	80	D1	00
40	B3	00	A9	40	95	00	90	40	81	80
50	81	40	71	4F	28	3C	80	A0	70	B0
60	23	40	30	20	36	00	51	73	21	00
70	00	1A	00	00	00	FF	00	51	46	47
80	30	37	30	31	30	30	30	30	31	0A
90	00	00	00	FD	00	32	4C	1E	52	11
100	00	0A	20	20	20	20	20	20	00	00
110	00	FC	00	56	58	32	38	33	35	77
120	6D	0A	20	20	20	20	01	4C		

-
- (08-09) ID Manufacturer Name _____ = VSC
 - (11-10) Product ID Code _____ = 0F1F
 - (12-15) Last 5 Digits of Serial Number _____ = Not Used
 - (16) Week of Manufacture _____ = 01
 - (17) Year of Manufacture _____ = 2007
 - (10-17) Complete Serial Number _____ = See Descriptor Block
 - (18) EDID Version Number _____ = 1
 - (19) EDID Revision Number _____ = 3
 - (20) VIDEO INPUT DEFINITION:
Digital Signal
Non - VESA DFP 1.x Compatible
 - (21) Maximum Horizontal Image Size _____ = 590 mm
 - (22) Maximum Vertical Image Size _____ = 370 mm

(23) Display Gamma _____ = 2.20

(24) Power Management and Supported Feature(s):
Active Off/Very Low Power, Standard Default Color Space,
Preferred Timing Mode
Display Type = R/G/B Color

(25-34) CHROMA INFO:
Red X - 0.650 Green X - 0.300 Blue X - 0.142 White X - 0.316
Red Y - 0.329 Green Y - 0.623 Blue Y - 0.065 White Y - 0.341

(35) ESTABLISHED TIMING I:
720 X 400 @ 70Hz (IBM,VGA)
640 X 480 @ 60Hz (IBM,VGA)
640 X 480 @ 67Hz (Apple,Mac II)
640 X 480 @ 72Hz (VESA)
640 X 480 @ 75Hz (VESA)
800 X 600 @ 56Hz (VESA)
800 X 600 @ 60Hz (VESA)

(36) ESTABLISHED TIMING II:
800 X 600 @ 72Hz (VESA)
800 X 600 @ 75Hz (VESA)
832 X 624 @ 75Hz (Apple,Mac II)
1024 X 768 @ 60Hz (VESA)
1024 X 768 @ 70Hz (VESA)
1024 X 768 @ 75Hz (VESA)
1280 X 1024 @ 75Hz (VESA)

(37) Manufacturer's Reserved Timing:
1152 X 870 @ 75Hz (Apple,Mac II)

(38-53) Standard Timing Identification:
1920 X 1200 @60Hz
1680 X 1050 @60Hz
1600 X 1200 @60Hz
1440 X 900 @60Hz
1400 X 1050 @60Hz
1280 X 1024 @60Hz
1280 X 960 @60Hz
1152 X 864 @75Hz

(54-71) Detailed Timing / Descriptor Block 1:
1920x1200 Pixel Clock: 154.00 MHz

Horizontal Image Size: 593 mm Vertical Image Size: 371 mm
Refreshed Mode: Non-Interlaced Normal Display - No Stereo

Horizontal:

Active Time: 1920 pixels

Blanking Time: 160 pixels

Sync Offset: 48 pixels

Sync Pulse Width: 32 pixels

Border: 0 pixels

Frequency: 74.04 KHz

Vertical:

Active Time: 1200 lines

Blanking Time: 35 lines

Sync Offset: 3 lines

Sync Pulse Width: 6 lines

Border: 0 lines

Frequency: 59.95 Hz

Digital Separate, Horizontal Polarity (+) Vertical Polarity (-)

(72-89) Detailed Timing / Descriptor Block 2:

Monitor Serial Number:

QFG070100001

(90-107) Detailed Timing / Descriptor Block 3:

Monitor Range Limits:

Min Vertical Freq - 50 Hz

Max Vertical Freq - 76 Hz

Min Horiz. Freq - 30 KHz

Max Horiz. Freq - 82 KHz

Pixel Clock - 170 MHz

Secondary GTF - Not Supported

(108-125) Detailed Timing / Descriptor Block 4:

Monitor Name:

VX2835wm

(126) Extension EDID Block(s): 1

(127) CheckSum OK

VIEWSONIC CORPORATION
EDID CEA-861B Timing Extension Version 3

EDID Block 1, Bytes 128-255

Block Type: CEA EDID Timing Extension

	0	1	2	3	4	5	6	7	8	9	
0		02	03	19	F1	46	90	04	05	07	03
10		0E	23	09	07	07	83	01	00	00	65
20		03	0C	00	10	00	02	3A	80	18	71
30		38	2D	40	58	2C	45	00	51	73	21
40		00	00	1F	01	1D	80	18	71	1C	16
50		20	58	2C	25	00	51	73	21	00	00
60		9E	8C	0A	D0	8A	20	E0	2D	10	10
70		3E	96	00	51	73	21	00	00	18	01
80		1D	00	72	51	D0	1E	20	6E	28	55
90		00	51	73	21	00	00	1E	00	00	00
100		00	00	00	00	00	00	00	00	00	00
110		00	00	00	00	00	00	00	00	00	00
120		00	00	00	00	00	00	00	33		

(2)Detailed Timing Start at - 25

(3)DTV Supports Underscan, DTV Supports Basic Audio

, DTV Supports YCbCr 4:4:4, DTV Supports YCbCr 4:2:2

, Native Format: 1

(4)Video Data Block/Short Video Descriptors, Number of Data Byte to Follow: 6

(5) 1920x1080p 59.94/60Hz 16:9 New Native

(6) 1280x720p 59.94/60Hz 16:9 861

(7) 1920x1080i 59.94/60Hz 16:9 861

(8) 720(1440)x480i 59.94/60Hz 16:9 New

(9) 720x480p 59.94/60Hz 16:9 861

(10) 640x480p 59.94/60Hz 4:3 861

(11)Audio Data Block, Number of Data Byte to Follow: 3, Uncompressed

(12) Audio Channels: 2, Linear PCM (IEC60958)

(13) Sampling Frequency: 32KHz, 44.1KHz, 48KHz,

(14) Sampling bit rate: 16 bit, 20 bit, 24 bit,

(15)Speaker Data Block, Number of Data Byte to Follow: 3

- (16-18) FL/FR,
- (19) Vendor Specific Data Block, Number of Data Byte to Follow: 5
- (20-22) Vendor IEEE Registration ID: 000C03 Hexadecimal
- (23-24) Vendor Specific Data: 1000 Hexadecimal

(25-42) Detailed Timing / Descriptor Block 1:
 1920x1080p Pixel Clock: 148.50 MHz

Horizontal Image Size: 593 mm	Vertical Image Size: 371 mm
Refreshed Mode: Non-Interlaced	Normal Display - No Stereo

Horizontal:

Active Time: 1920 pixels	Blanking Time: 280 pixels
Sync Offset: 88 pixels	Sync Pulse Width: 44 pixels
Border: 0 pixels	Frequency: 67.50 KHz

Vertical:

Active Time: 1080 lines	Blanking Time: 45 lines
Sync Offset: 4 lines	Sync Pulse Width: 5 lines
Border: 0 lines	Frequency: 60.00 Hz

Digital Separate, Horizontal Polarity (+) Vertical Polarity (+)

(43-60) Detailed Timing / Descriptor Block 2:
 1920x1080i Pixel Clock: 74.25 MHz

Horizontal Image Size: 593 mm	Vertical Image Size: 371 mm
Refreshed Mode: Interlaced	Normal Display - No Stereo

Horizontal:

Active Time: 1920 pixels	Blanking Time: 280 pixels
Sync Offset: 88 pixels	Sync Pulse Width: 44 pixels
Border: 0 pixels	Frequency: 33.75 KHz

Vertical:

Active Time: 540 lines	Blanking Time: 22 lines
Sync Offset: 2 lines	Sync Pulse Width: 5 lines
Border: 0 lines	Frequency: 60.05 Hz

Digital Separate, Horizontal Polarity (+) Vertical Polarity (+)

(61-78) Detailed Timing / Descriptor Block 3:
 720x480p Pixel Clock: 27.00 MHz

Horizontal Image Size: 593 mm	Vertical Image Size: 371 mm
Refreshed Mode: Non-Interlaced	Normal Display - No Stereo

Horizontal:

Active Time: 720 pixels

Blanking Time: 138 pixels

Sync Offset: 16 pixels

Sync Pulse Width: 62 pixels

Border: 0 pixels

Frequency: 31.47 KHz

Vertical:

Active Time: 480 lines

Blanking Time: 45 lines

Sync Offset: 9 lines

Sync Pulse Width: 6 lines

Border: 0 lines

Frequency: 59.94 Hz

Digital Separate, Horizontal Polarity (-) Vertical Polarity (-)

(79-96) Detailed Timing / Descriptor Block 4:

1280x720p Pixel Clock: 74.25 MHz

Horizontal Image Size: 593 mm

Vertical Image Size: 371 mm

Refreshed Mode: Non-Interlaced

Normal Display - No Stereo

Horizontal:

Active Time: 1280 pixels

Blanking Time: 370 pixels

Sync Offset: 110 pixels

Sync Pulse Width: 40 pixels

Border: 0 pixels

Frequency: 45.00 KHz

Vertical:

Active Time: 720 lines

Blanking Time: 30 lines

Sync Offset: 5 lines

Sync Pulse Width: 5 lines

Border: 0 lines

Frequency: 60.00 Hz

Digital Separate, Horizontal Polarity (+) Vertical Polarity (+)

(97-114) Detailed Timing / Descriptor Block 5:

No Data:

(115-126) No Data:

(127) CheckSum OK

Time: 17:19:17

Date: Wed Jan 17, 2007

VIEWSONIC CORPORATION
EDID Version # 1, Revision # 3
DDCTest For: ViewSonic VX2835wm

EDID Block 0, Bytes 0-127

128 BYTES OF EDID CODE:

	0	1	2	3	4	5	6	7	8	9
0	00	FF	FF	FF	FF	FF	FF	00	5A	63
10	1F	0F	01	01	01	01	01	11	01	03
20	80	3B	25	78	2E	9E	71	A6	54	4C
30	9F	24	10	51	57	BF	EF	80	D1	00
40	B3	00	A9	40	95	00	90	40	81	80
50	81	40	71	4F	28	3C	80	A0	70	B0
60	23	40	30	20	36	00	51	73	21	00
70	00	1A	00	00	00	FF	00	51	46	47
80	30	37	30	31	30	30	30	30	31	0A
90	00	00	00	FD	00	32	4C	1E	52	11
100	00	0A	20	20	20	20	20	20	00	00
110	00	FC	00	56	58	32	38	33	35	77
120	6D	0A	20	20	20	20	01	4C		

- (08-09) ID Manufacturer Name _____ = VSC
- (11-10) Product ID Code _____ = 0F1F
- (12-15) Last 5 Digits of Serial Number _____ = Not Used
- (16) Week of Manufacture _____ = 01
- (17) Year of Manufacture _____ = 2007
- (10-17) Complete Serial Number _____ = See Descriptor Block
- (18) EDID Version Number _____ = 1
- (19) EDID Revision Number _____ = 3
- (20) VIDEO INPUT DEFINITION:
Digital Signal
Non - VESA DFP 1.x Compatible
- (21) Maximum Horizontal Image Size _____ = 590 mm
- (22) Maximum Vertical Image Size _____ = 370 mm
- (23) Display Gamma _____ = 2.20
- (24) Power Management and Supported Feature(s):

Active Off/Very Low Power, Standard Default Color Space,

Preferred Timing Mode

Display Type = R/G/B Color

(25-34) CHROMA INFO:

Red X - 0.650 Green X - 0.300 Blue X - 0.142 White X - 0.316

Red Y - 0.329 Green Y - 0.623 Blue Y - 0.065 White Y - 0.341

(35) ESTABLISHED TIMING I:

720 X 400 @ 70Hz (IBM,VGA)

640 X 480 @ 60Hz (IBM,VGA)

640 X 480 @ 67Hz (Apple,Mac II)

640 X 480 @ 72Hz (VESA)

640 X 480 @ 75Hz (VESA)

800 X 600 @ 56Hz (VESA)

800 X 600 @ 60Hz (VESA)

(36) ESTABLISHED TIMING II:

800 X 600 @ 72Hz (VESA)

800 X 600 @ 75Hz (VESA)

832 X 624 @ 75Hz (Apple,Mac II)

1024 X 768 @ 60Hz (VESA)

1024 X 768 @ 70Hz (VESA)

1024 X 768 @ 75Hz (VESA)

1280 X 1024 @ 75Hz (VESA)

(37) Manufacturer's Reserved Timing:

1152 X 870 @ 75Hz (Apple,Mac II)

(38-53) Standard Timing Identification:

1920 X 1200 @60Hz

1680 X 1050 @60Hz

1600 X 1200 @60Hz

1440 X 900 @60Hz

1400 X 1050 @60Hz

1280 X 1024 @60Hz

1280 X 960 @60Hz

1152 X 864 @75Hz

(54-71) Detailed Timing / Descriptor Block 1:

1920x1200 Pixel Clock: 154.00 MHz

Horizontal Image Size: 593 mm

Vertical Image Size: 371 mm

Refreshed Mode: Non-Interlaced

Normal Display - No Stereo

Horizontal:

Active Time: 1920 pixels

Blanking Time: 160 pixels

Sync Offset: 48 pixels

Sync Pulse Width: 32 pixels

Border: 0 pixels

Frequency: 74.04 KHz

Vertical:

Active Time: 1200 lines

Blanking Time: 35 lines

Sync Offset: 3 lines

Sync Pulse Width: 6 lines

Border: 0 lines

Frequency: 59.95 Hz

Digital Separate, Horizontal Polarity (+) Vertical Polarity (-)

(72-89) Detailed Timing / Descriptor Block 2:

Monitor Serial Number:

QFG070100001

(90-107) Detailed Timing / Descriptor Block 3:

Monitor Range Limits:

Min Vertical Freq - 50 Hz

Max Vertical Freq - 76 Hz

Min Horiz. Freq - 30 KHz

Max Horiz. Freq - 82 KHz

Pixel Clock - 170 MHz

Secondary GTF - Not Supported

(108-125) Detailed Timing / Descriptor Block 4:

Monitor Name:

VX2835wm

(126) Extension EDID Block(s): 1

(127) CheckSum OK

VIEWSONIC CORPORATION
EDID CEA-861B Timing Extension Version 3

EDID Block 1, Bytes 128-255

Block Type: CEA EDID Timing Extension

	0	1	2	3	4	5	6	7	8	9	
0		02	03	1A	F1	47	9F	14	13	12	1E
10		16	01	23	09	07	07	83	01	00	00
20		65	0C	03	00	10	00	02	3A	80	D0
30		72	38	2D	40	10	2C	45	80	51	73
40		21	00	00	1F	01	1D	80	D0	72	1C
50		16	20	10	2C	25	80	51	73	21	00
60		00	9E	01	1D	00	BC	52	D0	1E	20
70		B8	28	55	40	51	73	21	00	00	1E
80		8C	0A	D0	90	20	40	31	20	0C	40
90		55	00	51	73	21	00	00	18	00	00
100		00	00	00	00	00	00	00	00	00	00
110		00	00	00	00	00	00	00	00	00	00
120		00	00	00	00	00	00	00	25		

(2)Detailed Timing Start at - 26

(3)DTV Supports Underscan, DTV Supports Basic Audio

, DTV Supports YCbCr 4:4:4, DTV Supports YCbCr 4:2:2

, Native Format: 1

(4)Video Data Block/Short Video Descriptors, Number of Data Byte to Follow: 7

(5) 1920x1080p 50Hz 16:9 New Native

(6) 1920x1080i 50Hz 16:9 861A

(7) 1280x720p 50Hz 16:9 861A

(8) 720x576p 50Hz 16:9 861A

(9) 1440x576p 50Hz 16:9 New

(10) 720(1440)x576i 50Hz 16:9 861A Optional

(11) 640x480p 59.94/60Hz 4:3 861

(12)Audio Data Block, Number of Data Byte to Follow: 3, Uncompressed

(13) Audio Channels: 2, Linear PCM (IEC60958)

(14) Sampling Frequency: 32KHz, 44.1KHz, 48KHz,

(15) Sampling bit rate: 16 bit, 20 bit, 24 bit,

- (16)Speaker Data Block, Number of Data Byte to Follow: 3
- (17-19) FL/FR,
- (20)Vendor Specific Data Block, Number of Data Byte to Follow: 5
- (21-23) Vendor IEEE Registration ID: 00030C Hexadecimal
- (24-25) Vendor Specific Data: 1000 Hexadecimal

(26-43) Detailed Timing / Descriptor Block 1:
 1920x1080p Pixel Clock: 148.50 MHz

Horizontal Image Size: 593 mm	Vertical Image Size: 371 mm
Refreshed Mode: Non-Interlaced	Normal Display - No Stereo

Horizontal:

Active Time: 1920 pixels	Blanking Time: 720 pixels
Sync Offset: 528 pixels	Sync Pulse Width: 44 pixels
Border: 0 pixels	Frequency: 56.25 KHz

Vertical:

Active Time: 1080 lines	Blanking Time: 45 lines
Sync Offset: 4 lines	Sync Pulse Width: 5 lines
Border: 0 lines	Frequency: 50.00 Hz

Digital Separate, Horizontal Polarity (+) Vertical Polarity (+)

(44-61) Detailed Timing / Descriptor Block 2:
 1920x1080i Pixel Clock: 74.25 MHz

Horizontal Image Size: 593 mm	Vertical Image Size: 371 mm
Refreshed Mode: Interlaced	Normal Display - No Stereo

Horizontal:

Active Time: 1920 pixels	Blanking Time: 720 pixels
Sync Offset: 528 pixels	Sync Pulse Width: 44 pixels
Border: 0 pixels	Frequency: 28.13 KHz

Vertical:

Active Time: 540 lines	Blanking Time: 22 lines
Sync Offset: 2 lines	Sync Pulse Width: 5 lines
Border: 0 lines	Frequency: 50.04 Hz

Digital Separate, Horizontal Polarity (+) Vertical Polarity (+)

(62-79) Detailed Timing / Descriptor Block 3:
 1280x720p Pixel Clock: 74.25 MHz

Horizontal Image Size: 593 mm	Vertical Image Size: 371 mm
Refreshed Mode: Non-Interlaced	Normal Display - No Stereo

Horizontal:

Active Time: 1280 pixels

Blanking Time: 700 pixels

Sync Offset: 440 pixels

Sync Pulse Width: 40 pixels

Border: 0 pixels

Frequency: 37.50 KHz

Vertical:

Active Time: 720 lines

Blanking Time: 30 lines

Sync Offset: 5 lines

Sync Pulse Width: 5 lines

Border: 0 lines

Frequency: 50.00 Hz

Digital Separate, Horizontal Polarity (+) Vertical Polarity (+)

(80-97) Detailed Timing / Descriptor Block 4:

720x576p Pixel Clock: 27.00 MHz

Horizontal Image Size: 593 mm

Vertical Image Size: 371 mm

Refreshed Mode: Non-Interlaced

Normal Display - No Stereo

Horizontal:

Active Time: 720 pixels

Blanking Time: 144 pixels

Sync Offset: 12 pixels

Sync Pulse Width: 64 pixels

Border: 0 pixels

Frequency: 31.25 KHz

Vertical:

Active Time: 576 lines

Blanking Time: 49 lines

Sync Offset: 5 lines

Sync Pulse Width: 5 lines

Border: 0 lines

Frequency: 50.00 Hz

Digital Separate, Horizontal Polarity (-) Vertical Polarity (-)

(98-115) Detailed Timing / Descriptor Block 5:

No Data:

(116-126) No Data:

(127) CheckSum OK

3. Front Panel Function Control Description

OSD Menu Controls

Select the menu items shown below by using the up [▲] and down [▼] buttons.

NOTE: All OSD menus and adjustment screens disappear automatically after about 15 seconds. This is adjustable through the OSD timeout setting in the setup menu.

- **Main Menu:**

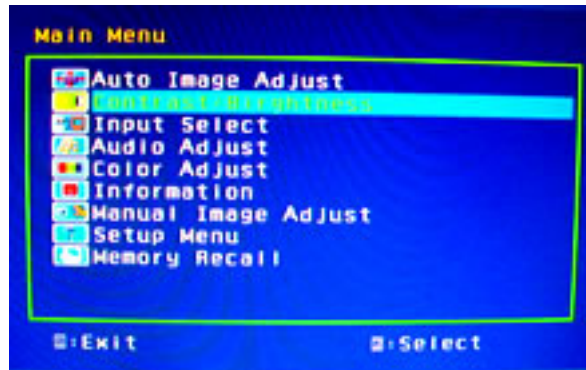

- **Auto Image Adjust:** Automatically adjust sizes and centers the screen image.

REMARK: There may need manual adjustment of “ phase ” for optimized performance for various VGA tolerance.

- **Contrast /Brightness:** To adjust the Contrast and Brightness of the LCD monitor.

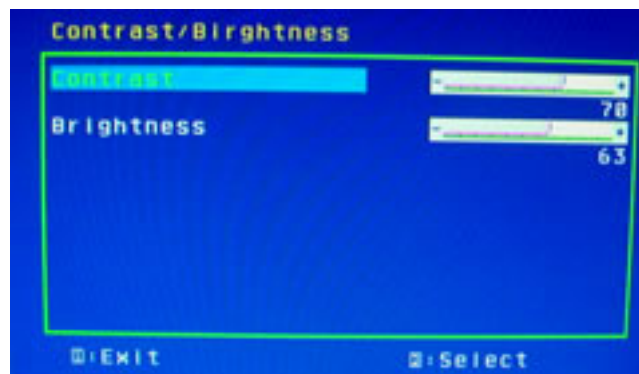

- **Input Select :** toggles between inputs if you have more than one computer connected to the VX2835wm. Please press the power on/off key to restart monitor when changing the HDMI input device.

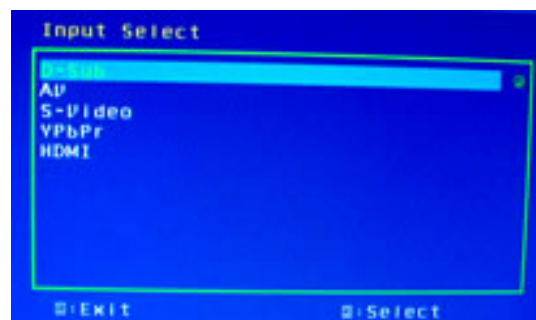

- **Audio Adjust : Volume** increases the volume, decreases the volume, and mutes the audio. Adjust **Base** and **Treble** level. **Balance** – adjust left and right speaker.

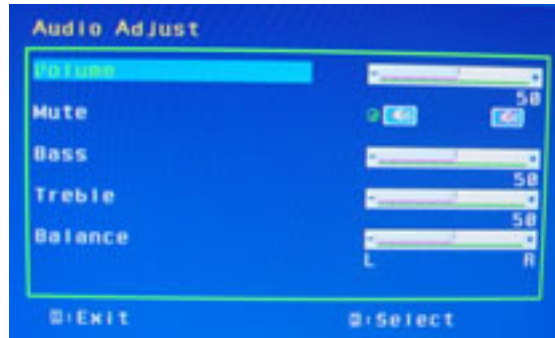

- **Color Adjust:** Provides several selection on color adjustment, including preset color temperatures and a User Color mode which allows independent adjustment of red (R), green (G), and blue (B). The factory setting for this product is 6500K.

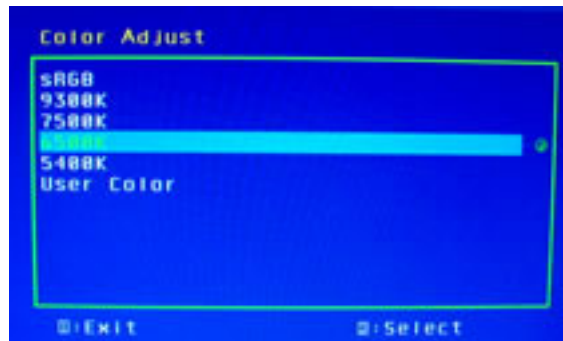

- **Information:** displays the timing mode (video signal input) coming from the graphics card in the computer, the LCD model number, the serial number, and the ViewSonic® website URL.



● **Manual Adjust :**

Horizontal Size: To adjust the horizontal pixel clock of the video.

H./V. Position: To adjust the horizontal and vertical position of the video.

Fine Tune: To adjust the delay time of data and clock.

Sharpness: To select the picture sharpness of display.

Tint : sharpens the focus by aligning text and/or graphics with pixel boundaries.

Color : Adjusts the saturation level of image. (It's inactive in D-SUB mode only)

Aspect Ratio : Selects the image size for 1:1, 4:3, 16:9 & full screen

OptiColor Mode : provides an optimum display environment depending on the contents displayed. It contains 7 user-selectable presets. These 7 presets are easily accessible from the short cut keys

OptiColor Skin Tone : includes 3 presets (Natural / Red Tone / Yellow Tone) which user can select according to user's preference.

PIP : Auto detection when the display has several inputs.

(1)When the display power on, the auto detect priority shall be as following:

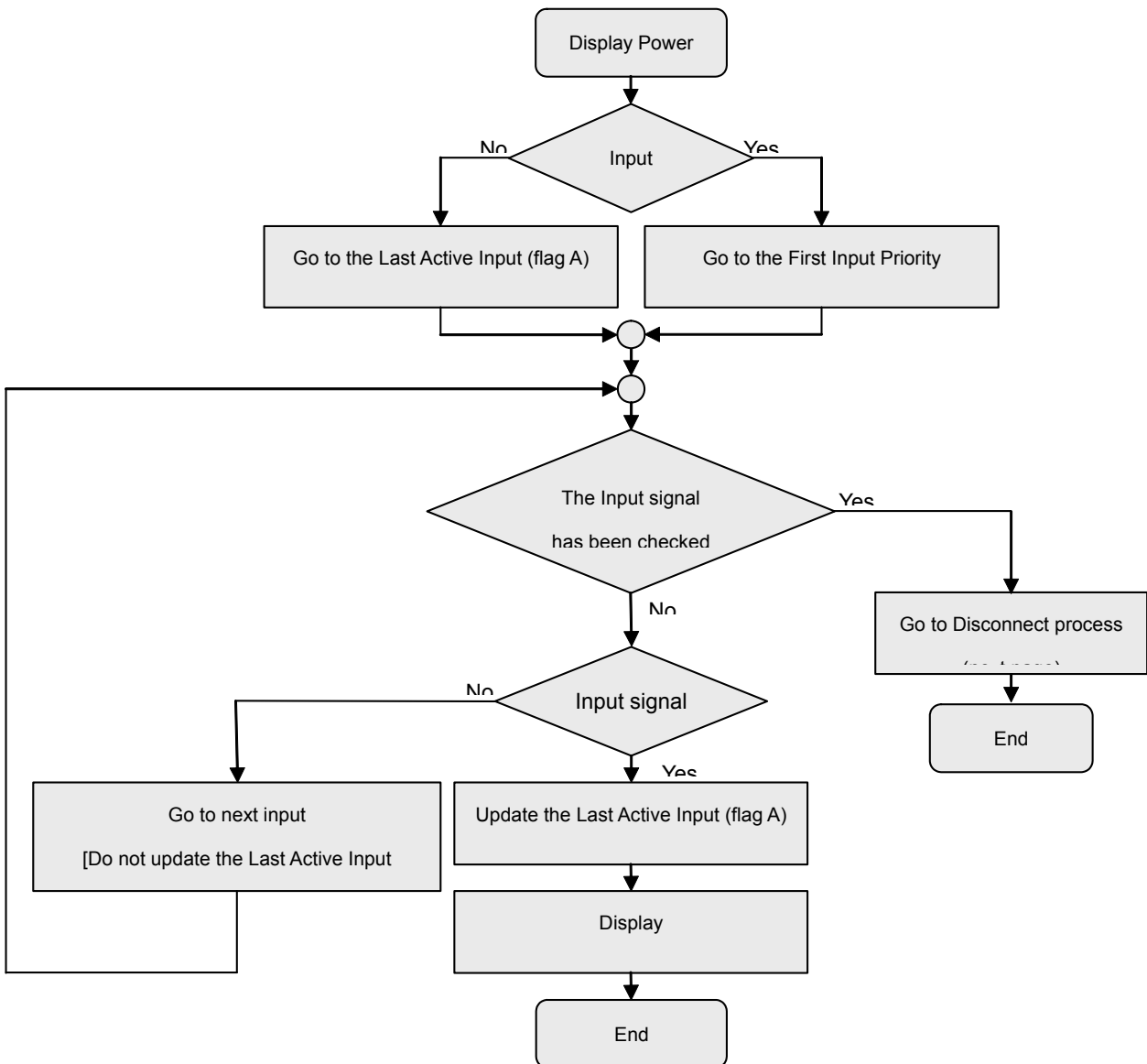

II) When the active input is disconnected, the auto detect priority shall be as follows :

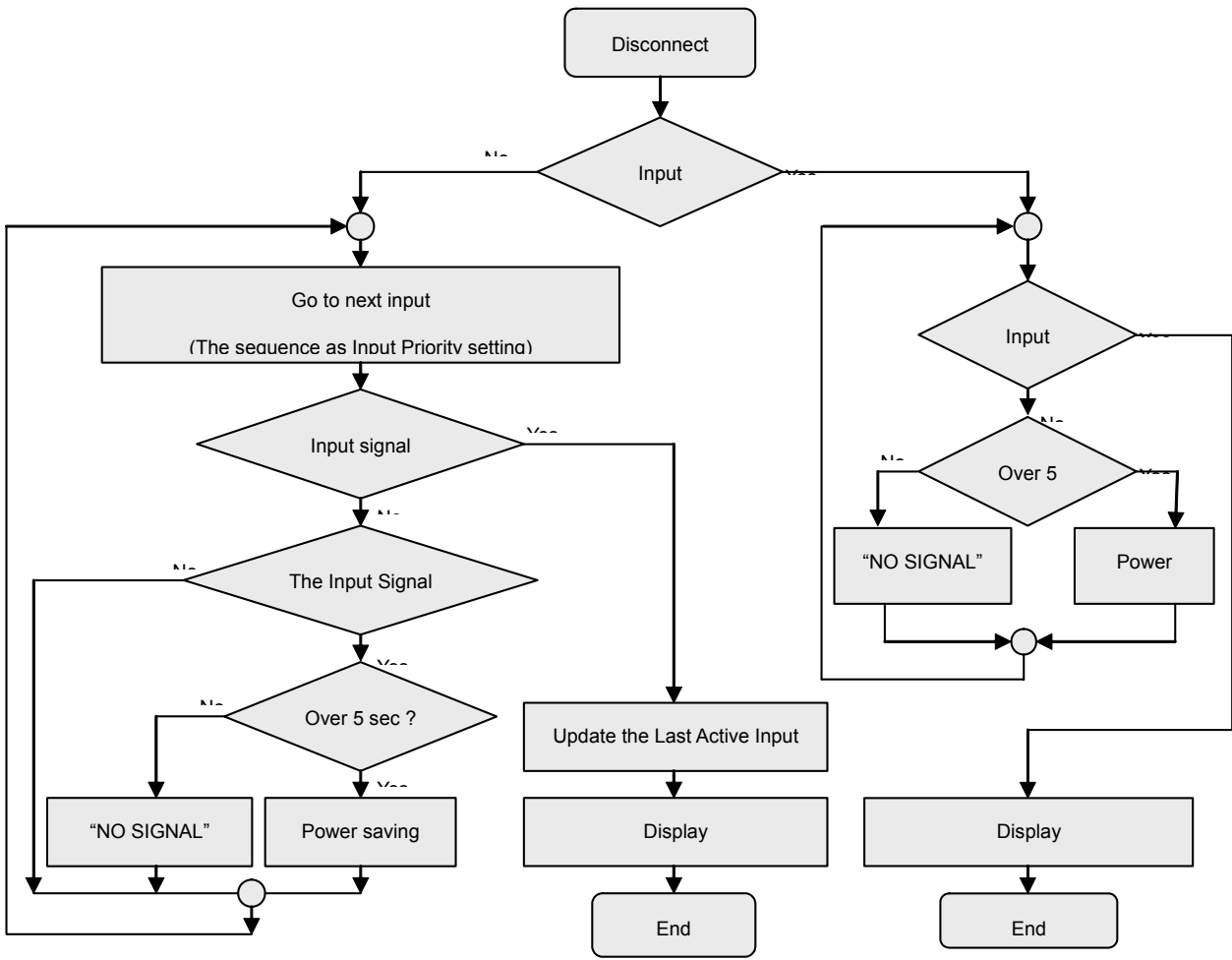

● Setup Menu::



Language Select: allows the user to choose the language used in the menus and control screens.

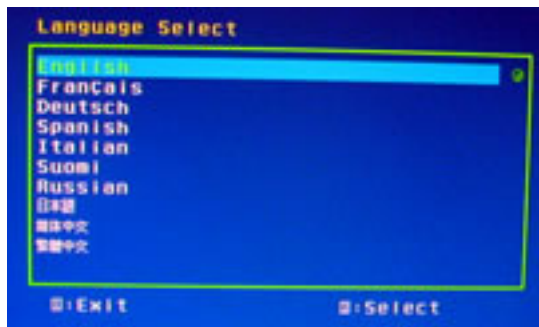

OSD Position: allows the user to move the OSD menus and control screen.

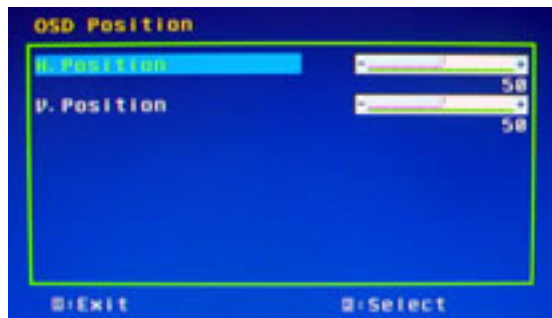

OSD Timeout: To set the displaying time of OSD menu in the screen.

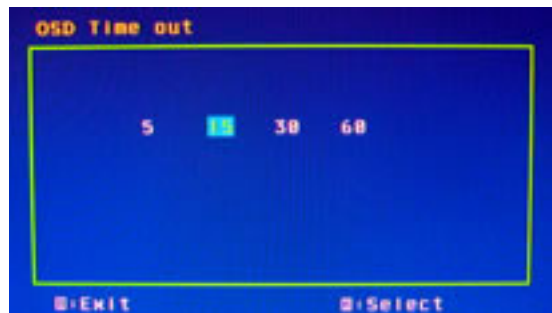

- **Memory Recall:**

Restore default settings of Clock, H./V. Position, Phase, Contrast, Brightness, Color temperature, OSD position, OSD timeout and Sharpness, Volume.

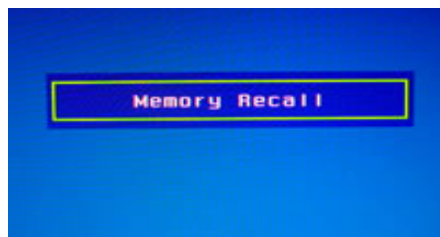

4. Circuit Description

Internal Power Supply	Part Number: 71-Y2831200G001
Input Voltage Range	AC90~264 (Worldwide)
Input Frequency Range	47 to 64 Hertz
Short Circuit Protection	Output can be shorted without damage
Over Current Protection	3.3~4.5A typ. at 5 VDC (Protect when short circuit)
Leakage Current	3.5mA (Max) at 264VAC / 50Hz
Efficiency	80 % typical at 115VAC Full Load
Fuse	Internal and not user replaceable
Power Dissipation	< 130 Watts (typ)
Max Input AC Current	1.6A (max)
Inrush Current (Cold Start)	80 A Max./ 240VAC / 50Hz (Cold Start at 25°C,Full Load)
Power Supply Cold Start	Shall start and function properly when under full load, with all combinations of input voltage, input frequency, and operating temperature
Power Supply Transient Immunity	Shall be able to withstand an ANSI/IEEE C62.41-1980 6000V 200 ampere ring wave transient test with no damage
Power Supply Line Surge Immunity	Shall be able to withstand 1.5 times nominal line voltage for one cycle with no damage
Power Supply Missing Cycle Immunity	Shall be able to function properly, without reset or visible screen artifacts, when ½ cycle of AC power is randomly missing at nominal input
Power Supply Acoustics	The power supply shall not produce audible noise that would be detectable by the user. Audible shall define to be in compliance with ISO 7779 (DIN EN27779:1991) Noise measurements of machines acoustics. Power Switch noise shall not be considered
US Type Power Cable Color = Black	Separate 3-prong NEMA 5-15P type plug. Length = 1.8m. Connects to display.
European Type Power Cable Color = Black	Schuko CEE7-7 type plug. Length = 1.8m, Connects to display.
CCC Type Power Cable Color = Black	Separate 3-prong type plug. Length = 1.8m. Connects to display.
PSE Type Power Cable Color = Black	Separate 2-prong NEMA 1-15P type plug. Length = 1.8m. Connects to display.
Power Saving Operation(Method)	VESA DPMS Signaling
Power Consumption	On Mode <60 W (Typ) / under 64W (Max for Energy Star) Max power output :130W(Max. @500nits) Saving Mode < 2 W@230VAC 50Hz Off Mode < 1 W @230VAC 50Hz (DC Power Off; Meet to Energy Star Ver4.0 Tier2)
Recovery Time	On Mode = N/A, Active Off < 3 sec

5. Adjustment Procedure

5.1. Function Test

5.1.1 Product

- 28" LCD Monitor

5.1.2 Test Equipment

- Color Video Signal & Pattern (or PC with SXGA resolution and a sound card)

5.1.3 Test Condition

Before function test and alignment, each LCD Monitor should be run-in and warmed up for at least 30 minutes with the following conditions:

- (a) In room temperature,
- (b) With full-white screen, RGB, and Black
- (c) With cycled display modes,
 - 640*480 (H=43.27kHz, V=85Hz)
 - 800*600 (H=53.7kHz, V=85Hz)
 - 1024*768 (H=68.67kHz, V=85Hz)
 - 1280*1024 (H=79.97kHz, V=75Hz)

5.2 Test Display Modes & Pattern

5.2.1. Compatible Modes

Analog
1. 640 x 350 @ 70Hz, 31.5kHz
2. 640 x 480 @ 60Hz, 31.5kHz
3. 640 x 480 @ 67Hz, 35.0kHz
4. 640 x 480 @ 75Hz, 37.5kHz
5. 640 x 480 @ 72Hz, 37.9kHz
6. 640 x 480 @ 85Hz, 43.27kHz
7. 720 x 400 @ 70Hz, 31.5kHz
8. 800 x 600 @ 56Hz, 35.1kHz
9. 800 x 600 @ 60Hz, 37.9kHz
10. 800 x 600 @ 75Hz, 46.9kHz
11. 800 x 600 @ 72Hz, 48.1kHz
12. 800 x 600 @ 85Hz, 53.7kHz
13. 832 x 624 @ 75Hz, 49.7kHz
14. 1024 x 768 @ 60Hz, 48.4kHz
15. 1024 x 768 @ 70Hz, 56.5kHz
16. 1024 x 768 @ 72Hz, 58.1kHz
17. 1024 x 768 @ 75Hz, 60.0kHz
18. 1024 x 768 @ 85Hz, 68.67kHz
19. 1280 x 1024 @ 60Hz, 63.4kHz
20. 1280 x 1024 @ 75Hz, 79.97kHz

5.2.2 Function Test Display Pattern

Item	Test Content	Pattern	Specification	Remark
1	Frequency & Tracking	Fine Line Moire	Eliminate visual wavy noise.	Figure 1
2	Contrast/Brightness	16 Gray Scale	16 gray levels should be distinguishable.	Figure 2
3	Boundary	Horizontal & Vertical Thickness	Horizontal and Vertical position of video should be adjustable to be within the screen frame.	Figure 3
4	RGB Color Performance	RGB Color Intensities	Contrast of each R, G, B, color should be normal.	Figure 4, 5, 6
5	Screen Uniformity & Flicker	Full White	Should be compliant with the spec.	Figure 7
6	Dead Pixel/Line	White Screen & Dark Screen	The numbers of dead pixels should be compliant with the spec.	Figure 7, 8
7	White Balance	White & Black Pattern	The screen must have the pure white and black pattern, no other color.	Figure 9

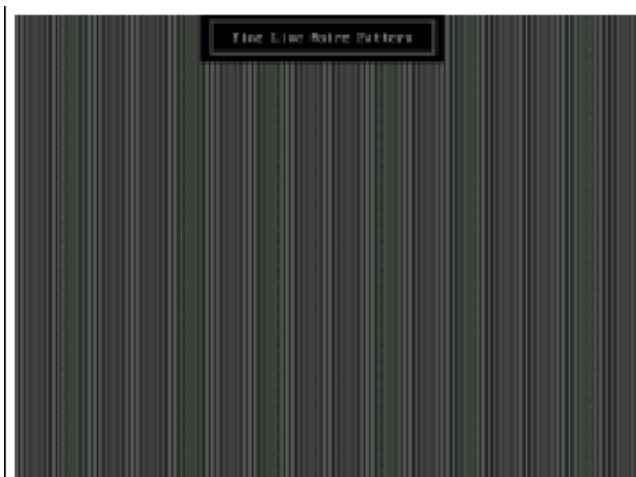

Fine Line Moire Pattern (Figure 1)



Gray Scale Pattern (Figure 2)



Horizontal & Vertical Thickness Pattern (Figure 3)

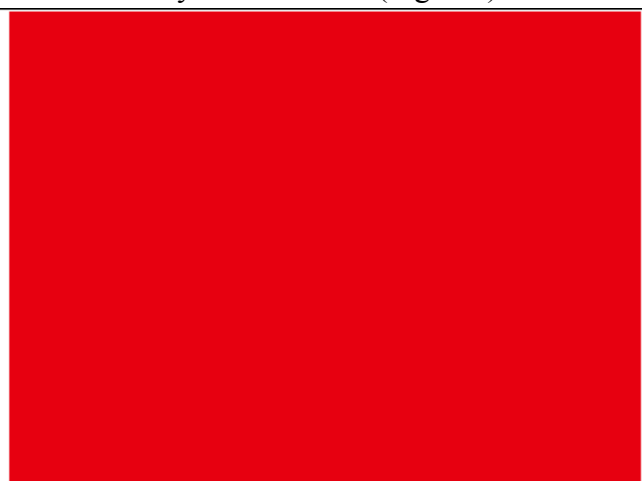

R. Color Pattern (Figure 4)



G. Color Pattern (Figure 5)



B. Color Pattern (Figure 6)



Full White Patter (Figure 7)



Dark Screen Pattern (Figure 8)

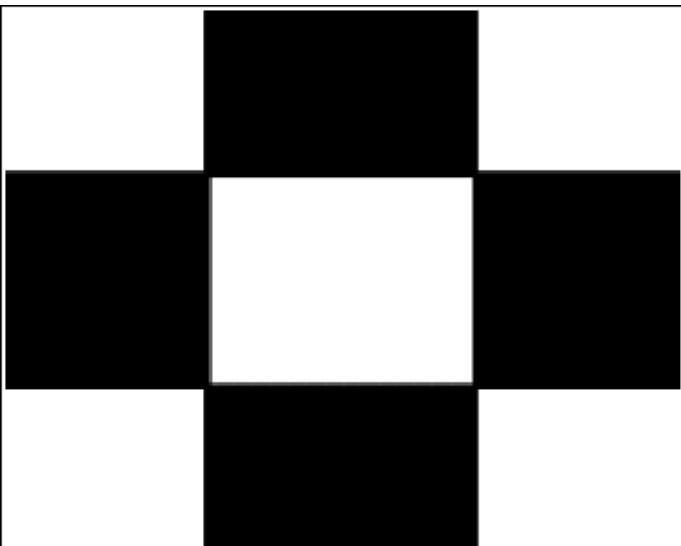

Black-White Pattern (Figure 9)

5.3 Function Test and Alignment Procedure

5.3.1 All Modes Reset

You should do “All Mode Reset” first. This action will allow you to erase all end-user’s settings and restore the factory defaults.

5.3.2 Auto Image Adjust

Please select and enter “*Auto Image Adjust*” function on Main Menu to see if it is workable. The “*Auto Image Adjust*” function is aimed to offer a better screen quality by built-in ASIC. For optimum screen quality, the user has to adjust each function manually.

5.3.3 Firmware

Test Pattern: Burn In Mode (Refer to Chapter III-3. Hot Keys for Function Controls)

- Make sure the F/W is the latest version.

5.3.4 DDC

Test Pattern: EDID program

- Make sure it can pass test program.

5.3.5 Fine Tune and Sharpness

Test Signal: 1280*1024@60Hz

Test Pattern: Line Moire Pattern

- Check and see if the image has noise and focus performs well. Eliminate visual line bar.

- If not, readjust by the following steps:

(a) Select and enter “**Fine Tune**” function on “**Manual Image Adjust**” to adjust the image to eliminate visual wavy noise.

(b) Then, select and enter “**Sharpness**” function to adjust the clarity and focus of the screen image.

5.3.6 Boundary

Test Signal: 1280*1024@60Hz

Test Pattern: Horizontal & Vertical Line Thickness Pattern

- Check and see if the image boundary is within the screen frame.

- If not, readjust by the following steps:

(a) Select and enter “**Manual Image Adjust**” function on OSD Main Menu.

(b) Then, select and enter “**Horizontal Size**” or “**Horizontal/Vertical Position**” function to adjust the video boundary to be full scanned and within screen frame.

5.3.7 White Balance

Test Signal: 1280*1024@60Hz

Test Pattern: White and Black Pattern

5.3.8 R, G, B, Colors Contrast

Test Signal: 1280*1024@60Hz

Test Pattern: R, G, B, Color Intensities Pattern and 16 Gray Scale Pattern

- Check and see if each color is normal and distinguishable.
- If not, please return the unit to repair area.

5.3.9 Screen Uniformity and Flicker

Test Signal: 1280*1024@60Hz

Test Pattern: Full White Pattern

- Check and see if it is in normal condition.

5.3.10 Dead Pixel and Line

Test Signal: 1280*1024@60Hz

Test Pattern: Dark and White Screen Pattern

- Check and see if there are dead pixels on LCD panel with shadow gauge and filter film.
- The total numbers and distance of dead pixels should be compliant with the spec.

5.3.11 Mura

Test Pattern: White, RGB, Black, & Grey

Test Tool: 8% ND Filter

- Check if the Mura can pass 8% ND Filter.

5.3.12 Audio

Test Signal: Voice signal (optional, depend on model)

Test Pattern: liberty

- Make sure there is audio output.
- Make sure that audio function (volume \leq 80%) is working without noise and resonance.
- Make sure that the sound of right and left speakers are in balance.

5.3.13 Check for Secondary Display Modes

Test Signal:

Analog: 640*350@70Hz; 640*480@60HZ

720*400@70Hz; 800*600@60HZ/70HZ/75HZ

832*624@75Hz, 1024*768@60HZ/70HZ/75HZ

1280*1024@60/75Hz

- Normally when the primary mode 1280*1024@60Hz is well adjusted and compliant with the specification, the secondary display modes will be great possible to be compliant with the spec. But we still have to check with the general test pattern to make sure every secondary is compliant with the specification.

5.3. 14 All Modes Reset

After final QC step, we have to erase all saved changes again and restore the factory defaults. You should do “All Mode Reset” again.

5.3.15 Power Off Monitor

Turn off the monitor by pressing “Power” button.

5.4 Firmware Upgrade Procedure

5.4.1 Equipment needed :



Use 15 pin D-Sub and USB cable



ISP tool

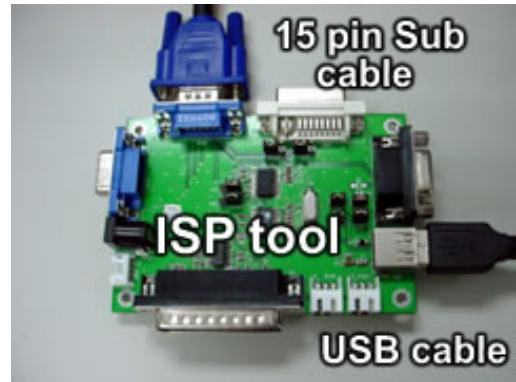

ISP connection

5.4.2 Hardware setup connection :

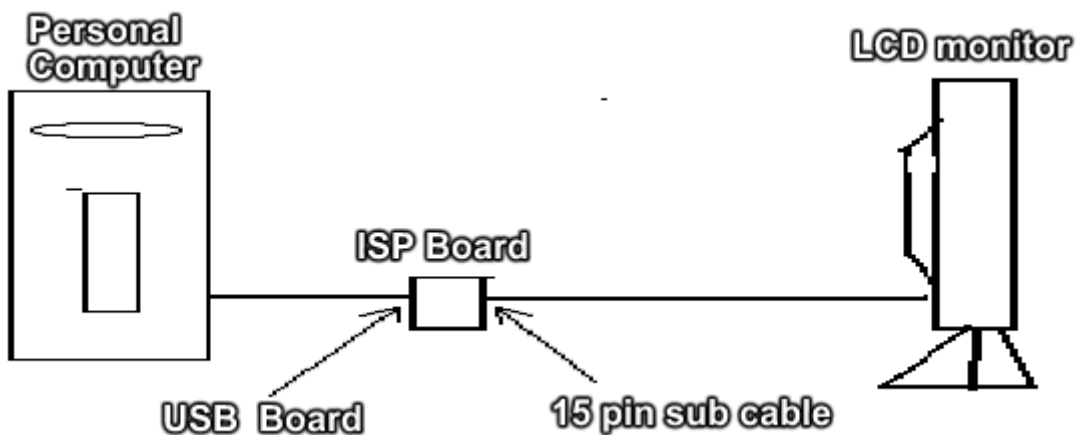

5.4.3 How to check current Firmware version

- 4.1.1 Press Up and Down arrow button at the same time for 3 seconds and then release.
- 4.1.2 Press Power button and wait for the blue screen to display.
- 4.1.3 Press 1 immediately and the firmware version screen will display on the screen.

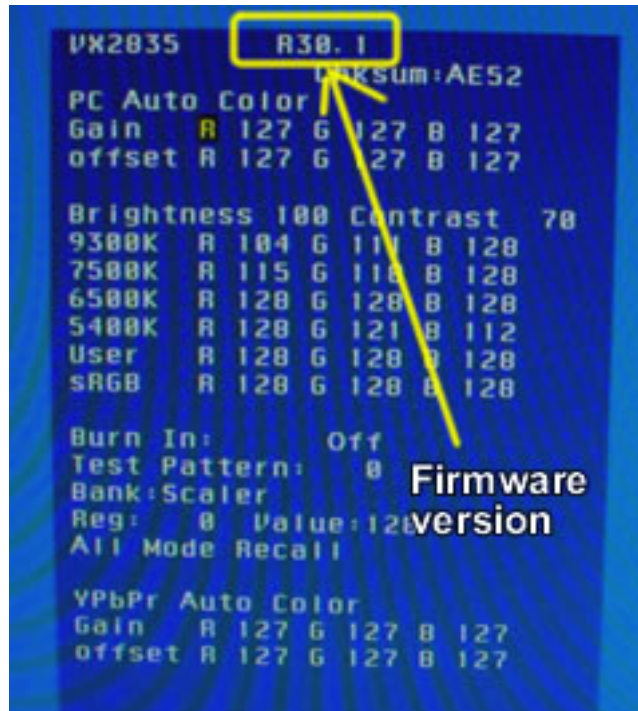

5.4.4 Procedure to update firmware version

Setup procedure to update Bin and Hex Firmware

1. Make sure the USB cable and 15 pin Sub cable are properly connected to the PC computer and LCD monitor.

Execute the software program



2. Click "Yes" to continue

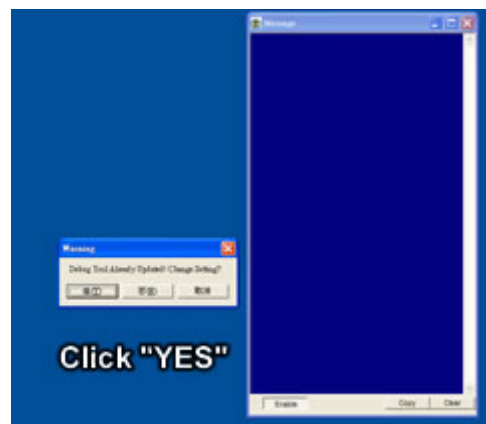

- Click the connection icon and the LED should turn to GREEN color (means connected)

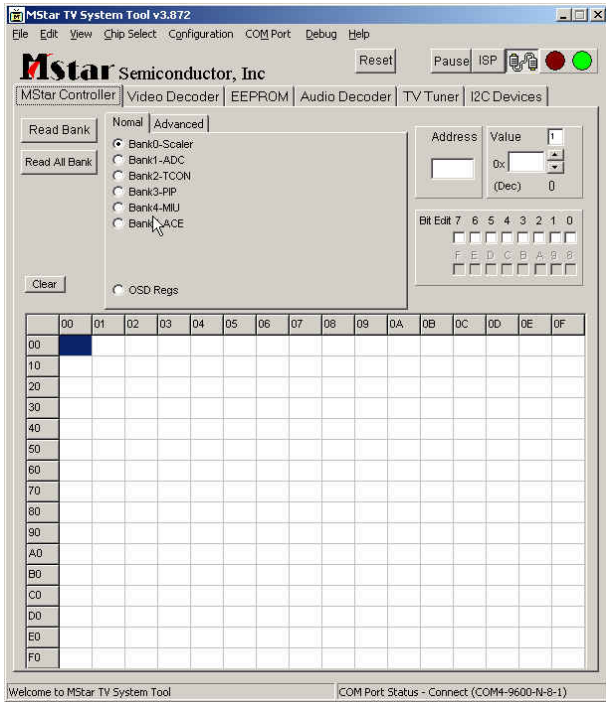

- Mstar Chip set - Select 5151A series
- Debug Interace - Select COMPORT
- COM Port - you need to check the assigned COM Port under Control Panel
→ Device Manager → Com Port
- Com Port Protocol – select TV

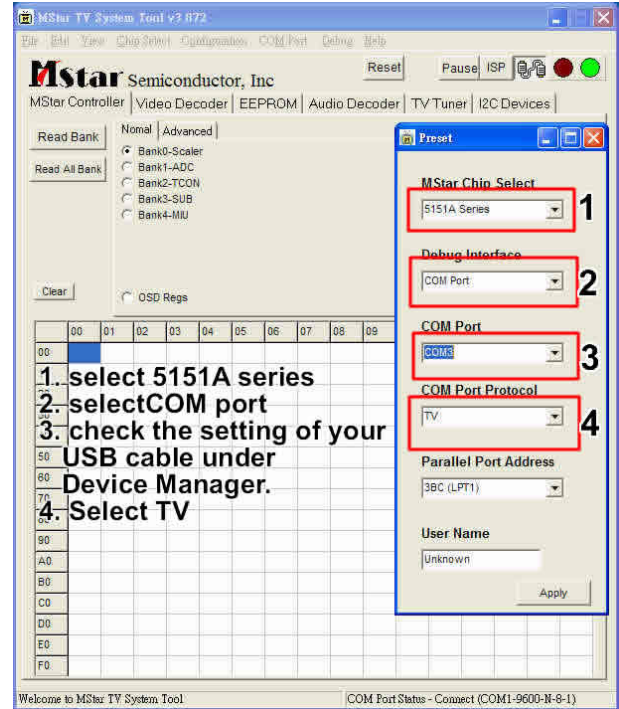

- select 5151A series
- select COM port
- check the setting of your USB cable under Device Manager.
- Select TV

Start to do firmware BIN update

- On the top menu, click VIEW → Direct SPIU Flash Management

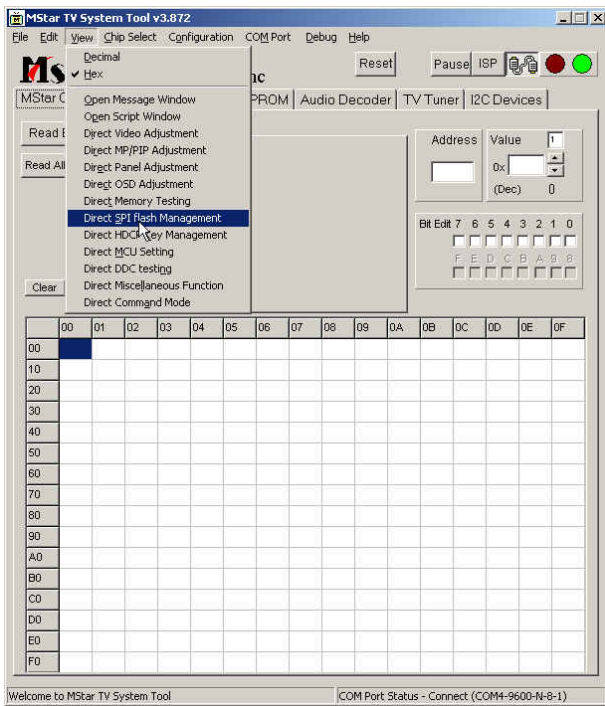

- Click "Load"

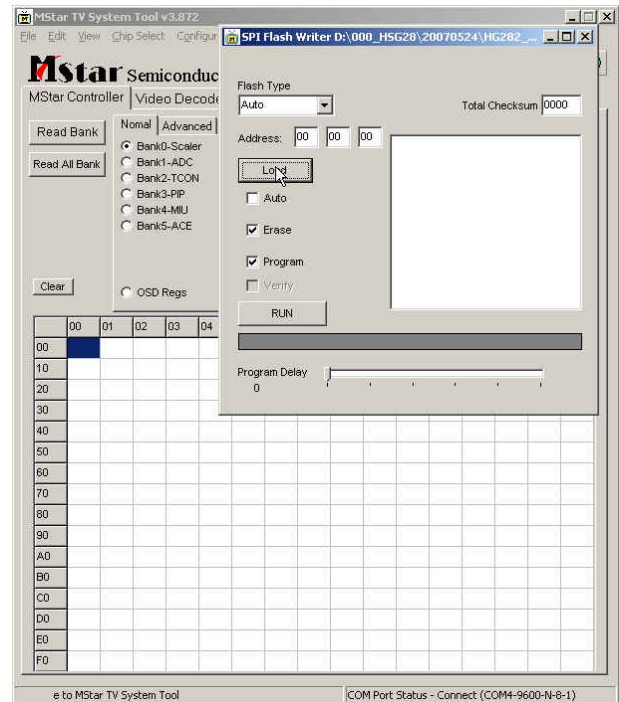

7. Locate and load the bios file

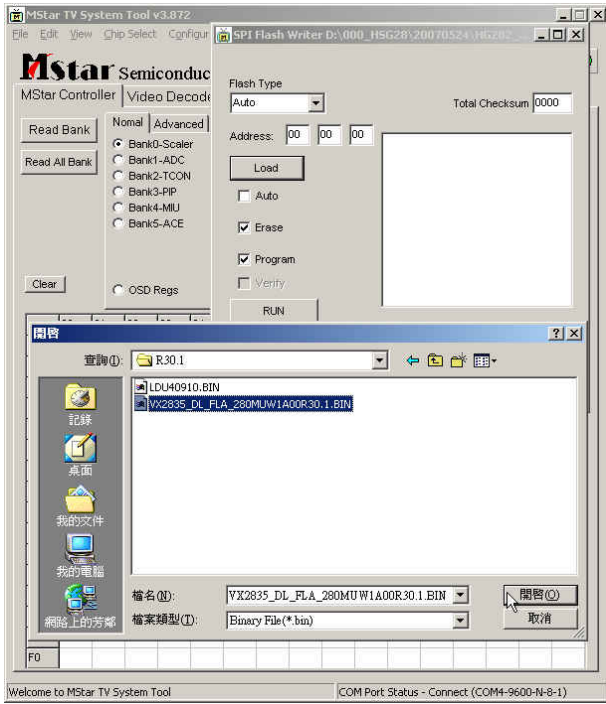

8. Set the Program Delay to "3"

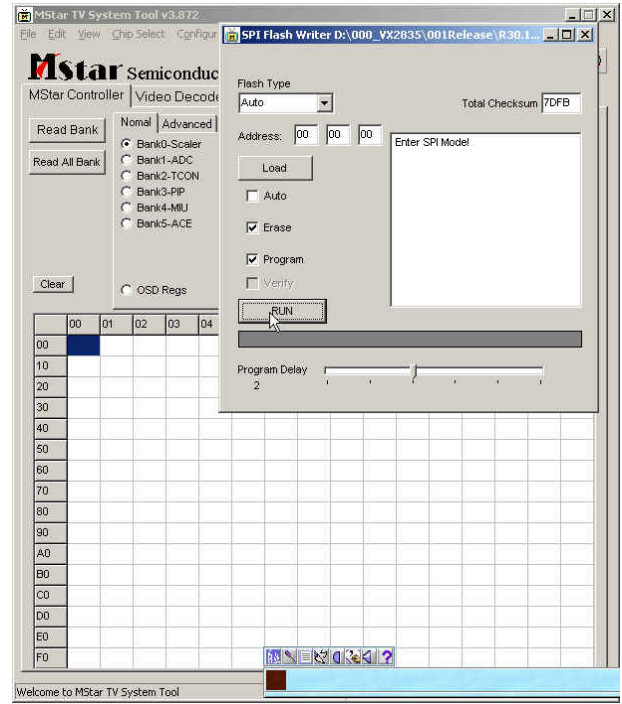

9. Click "RUN"

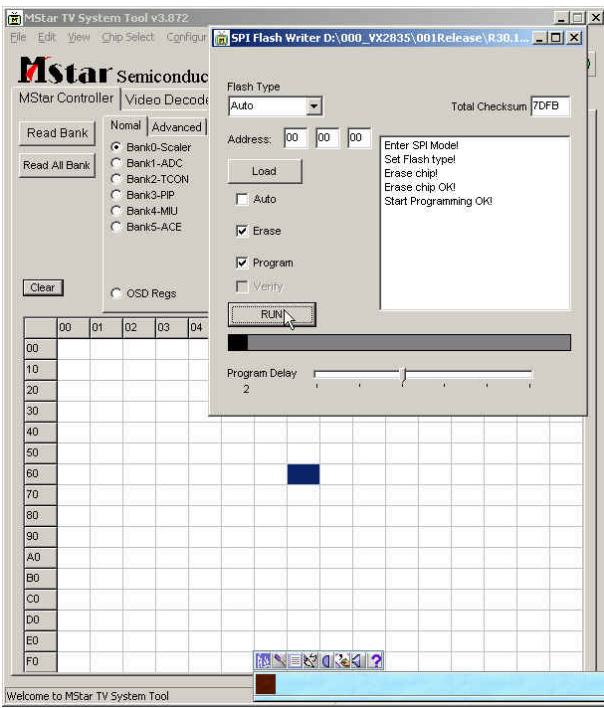

10. Exit after seeing "OK". Disconnect all cables and turn off all AC power.

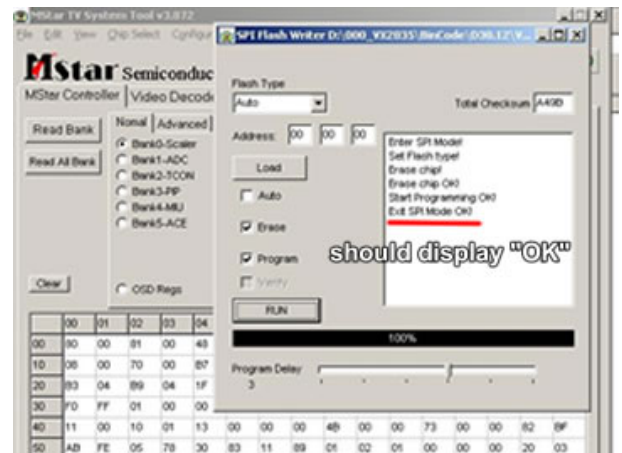

Start to do firmware HEX update (you need to follow set up procedure 1 to 4 before proceeding to this step)

1. Click ISP, on the top menu, select configuration
 → ISP Setting → File Path of external ISP tool

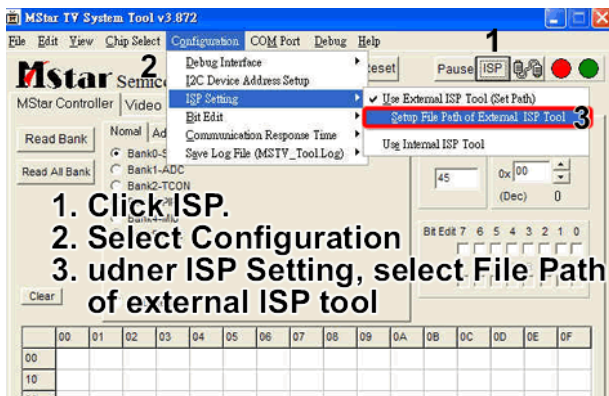

2. Locate the file for 8051ISP writer

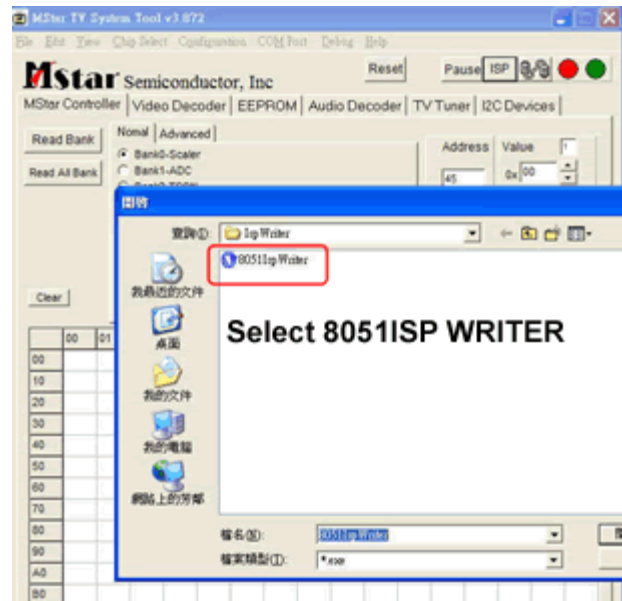

3. Select the correct chip (W79E632) and select the hex file.

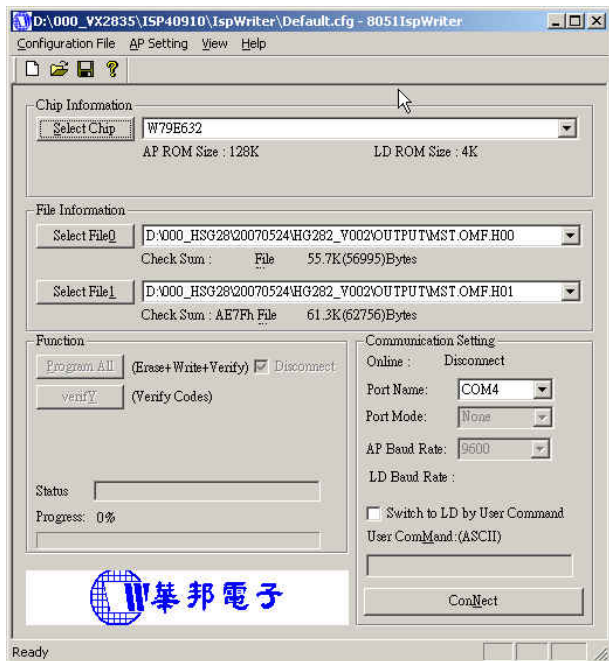

4. Select HEX format

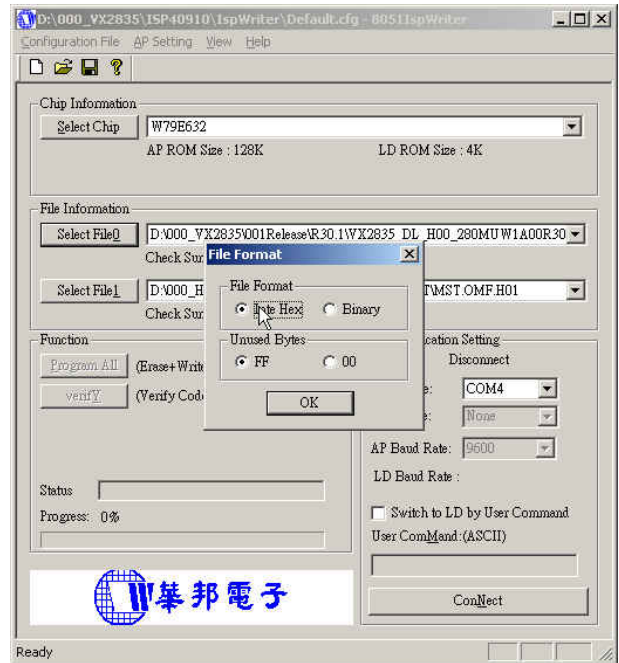

5. Select the second HEX file

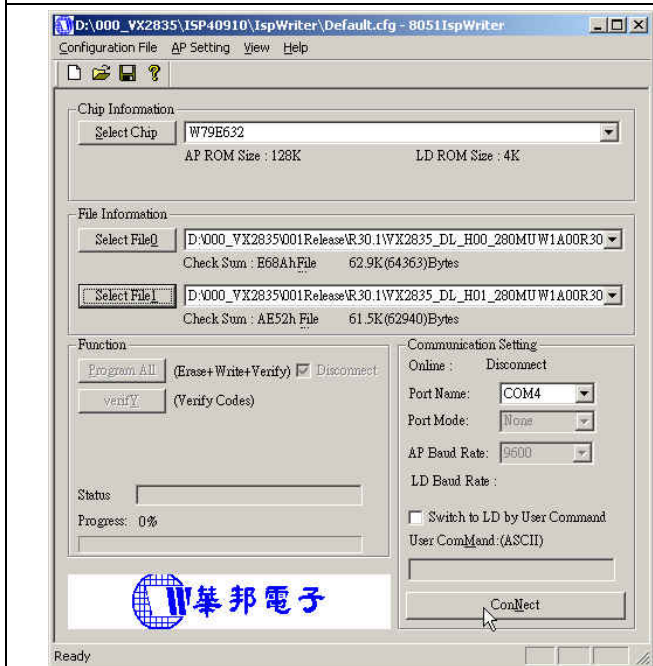

6. Select HEX format

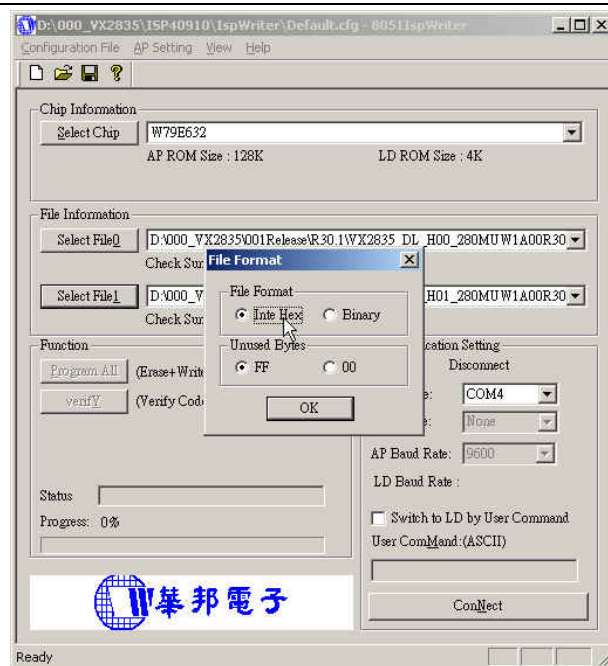

7. Check the com port setting (Control Panel → System → Device Manager → COMP PORT. Click “Connect Next Chip”
Click Program All

8. Program OK - Done

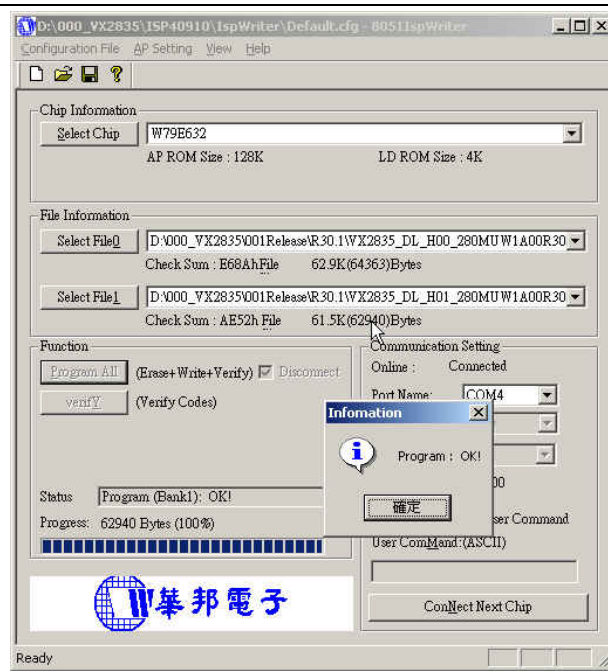
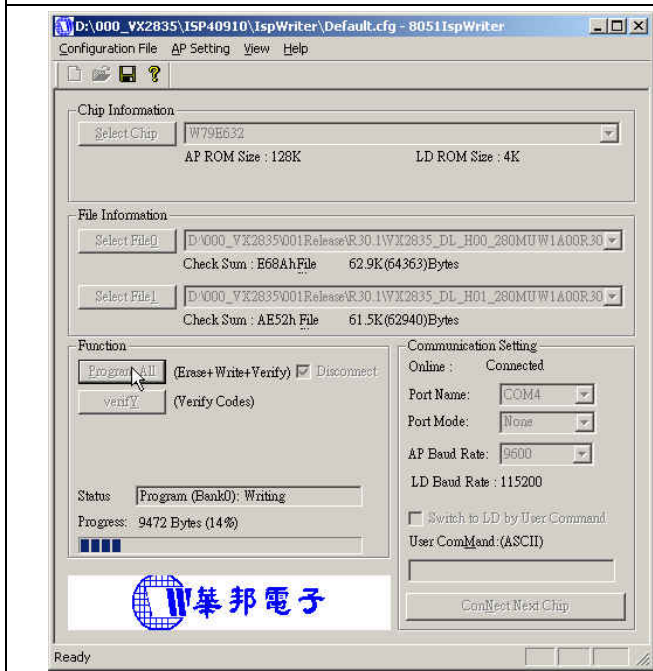

5.5.6 DDC Key In Procedure

Note:

1. Every time after replacing the main board, you have to do the DDC key in.
2. If you find the DDC does not conform to the monitor, you have to do the DDC key in.

Equipment Needed

- VX2835 LCD Monitor
- DDC Card
- PC
- RS232 cable
- HDMI Cable



DDC Card (D8330)



RS-232 Cable



VGA Cable

Step 1 : Select VX2835 on Working Model column to show EDID data on left

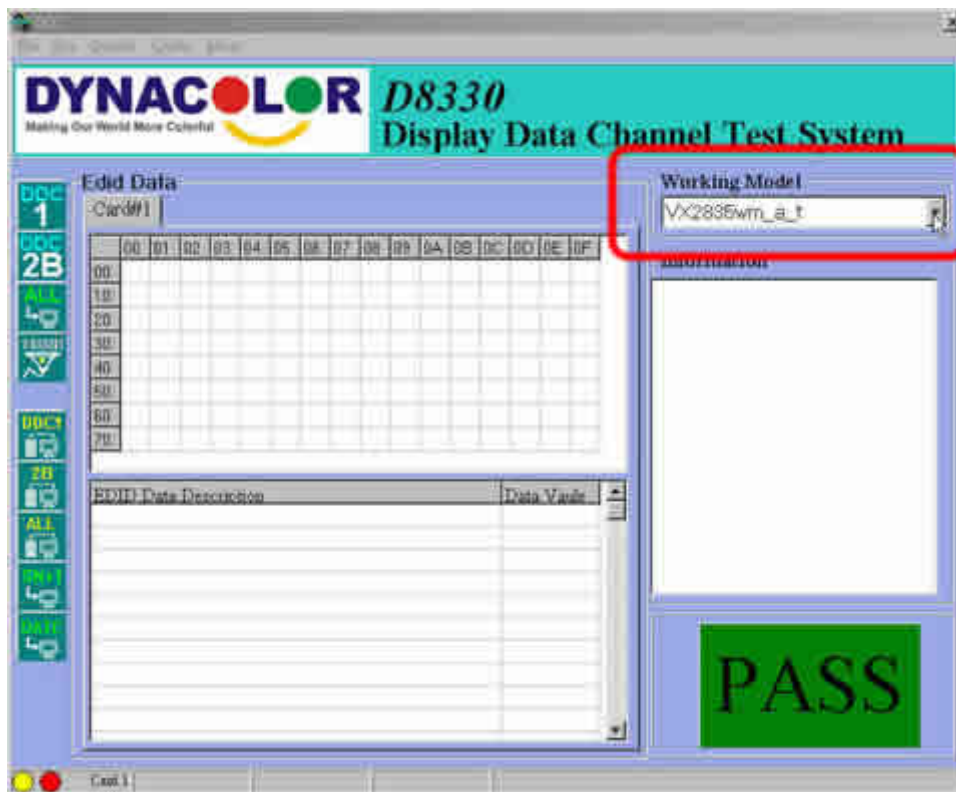

Step 2 : Modify the column of Week of Manufacture and Year of Manufacture and ID serial Number then press “2B” button for changing serial number data.

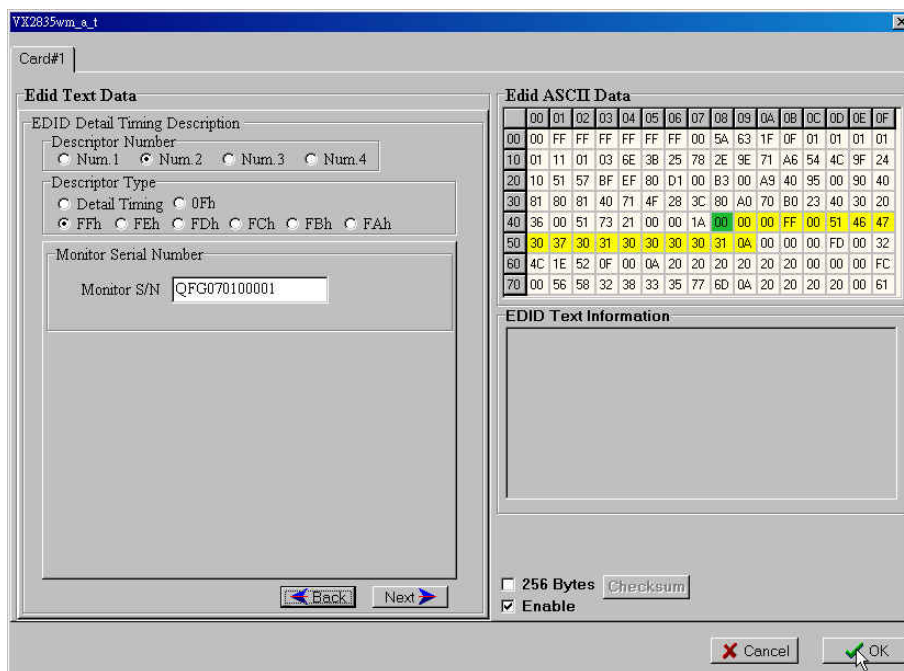

Step 3 : You will see the result as follows.



5.6 Disassembly Procedure

1. Put the LCD monitor on a flat table, make sure the table surface with cover with foam to protect the LCD panel from scratch.

Make sure also that there is no object underneath the LCD monitor before putting the LCD down



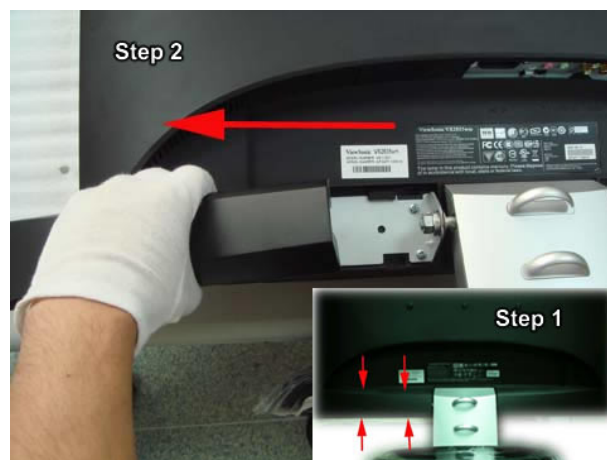

2. Follow step 1, press both sides of the hinge cover, then proceed to step 2, pull out the left cover to remove.

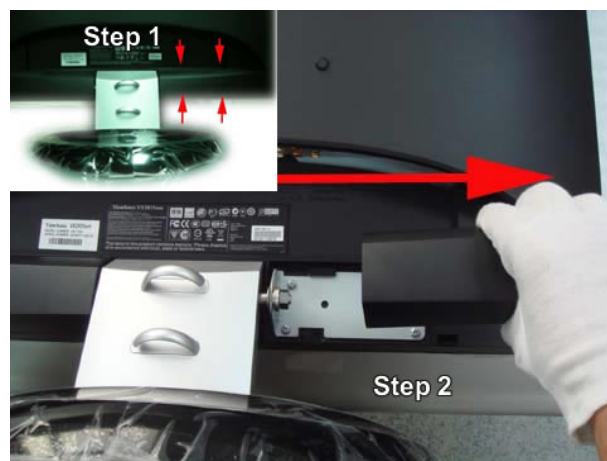

3. Follow step 1, press both sides of the hinge cover, then proceed to step 2, pull out the right cover to remove.

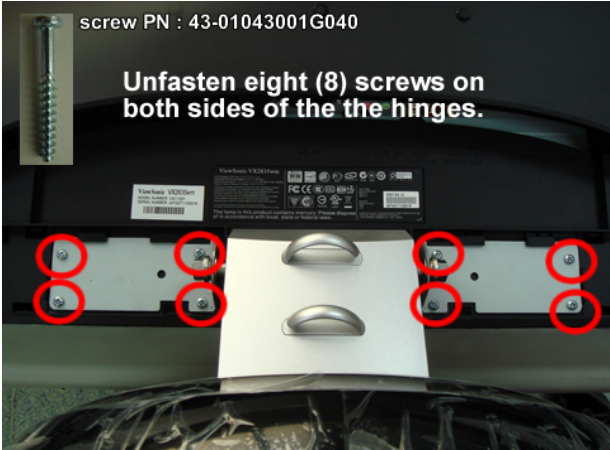

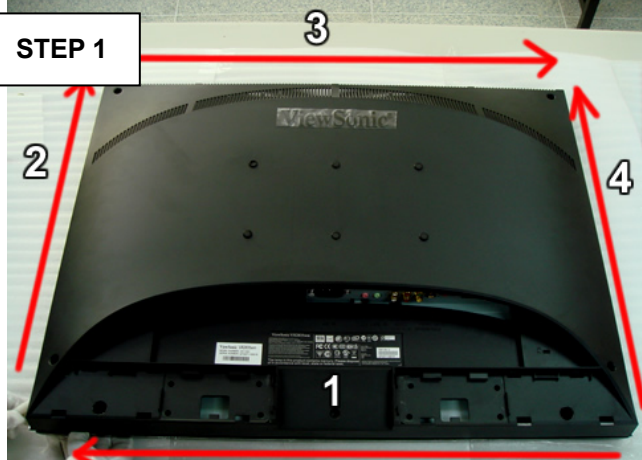
<p>4. Unfasten eight (8) screws on both sides of the ARM hinge.</p>	
<p>5. Gently remove the base stand assembly to separate from the LCD monitor.</p>	
<p>6. Unfasten seven (7) pcs screws on the back cover of the LCD monitor.</p>	
<p>7. To remove the back cover, start from the lower left corner. Use a plastic tool (flat) and insert on the opening on the lower left corner. Follow the number.</p>	

STEP 2

Insert the plastic tool on the small opening.

Gently move the plastic tool along the sides to release the snap locks on four sides of the back cover

STEP 3

Gently remove the back cover to separate from the front bezel

8. Unfasten six (6) screws on the hinge bracket.

Unfasten six screws on the hinge bracket

HINGE BRACKET SCREW
PN : 43-10040602G000

9. You can now remove the left speaker.
Disconnect the speaker cable from the connector.

Remove the black insulation tape and disconnect the speaker cable.

10. You can now remove the right speaker.
Disconnect the speaker cable from the connector.

Remove the black insulation tape and disconnect the speaker cable.

11. Remove the black insulation tape along the left, right and upper sides of the LCD panel.

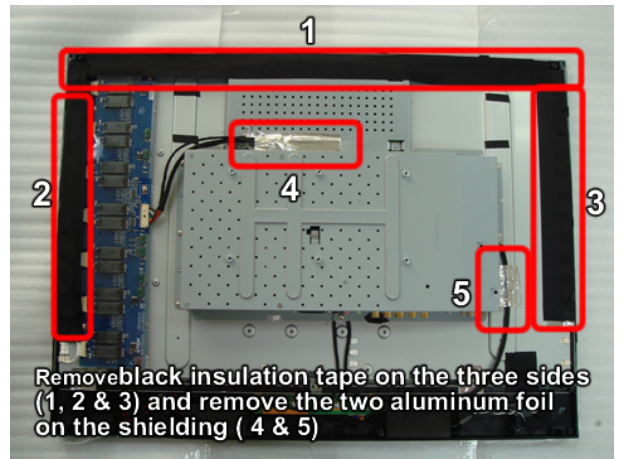

12. Disconnect the keyboard cable.

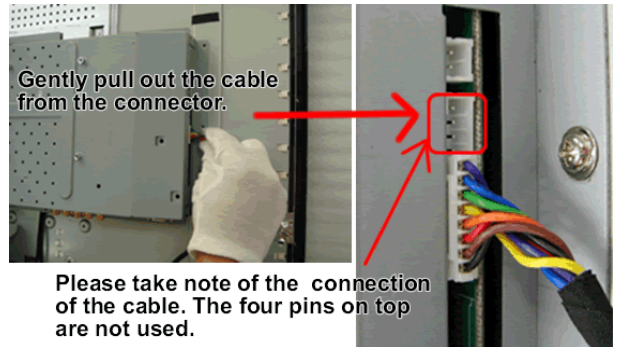

13. Unfasten four (4) screws on the key board.

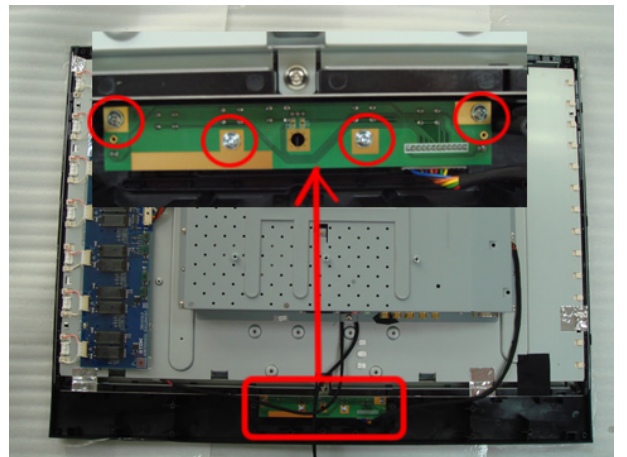

14. Unfasten seven (7) pcs screws on the shielding.

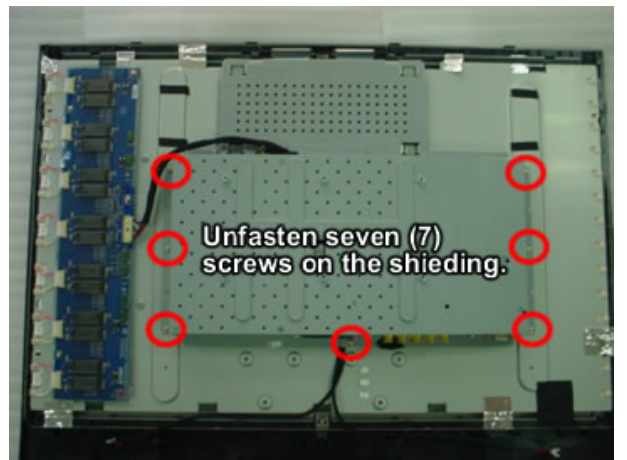

15. Step 1 - Disconnect the cable from the connector.

Step 2 - Gently lift up the shielding **half way**, and disconnect the cable underneath. To disconnect the cable, hold and press the end cable and gently pull out from the connector to disconnect.

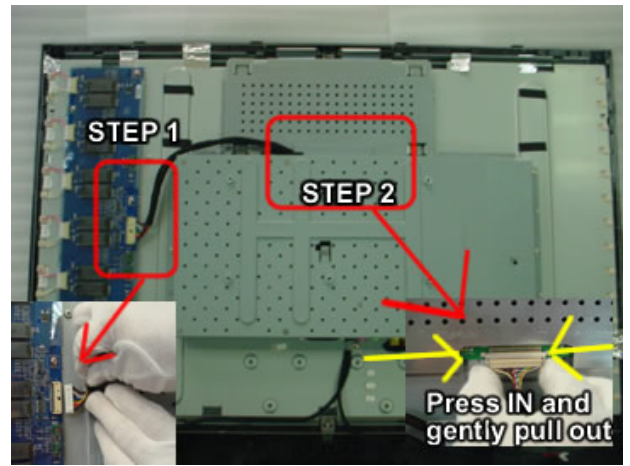

16. Unfasten two (2) screws on the upper and bottom sides of the LCD module.

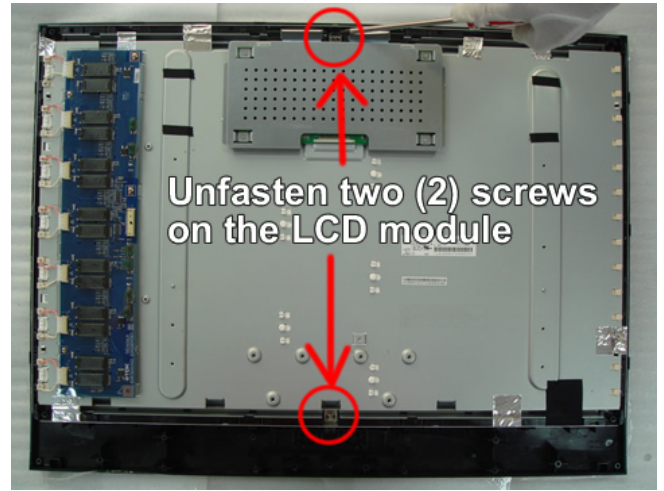

17. Release all the snap locks along the four sides of the LCD screen.

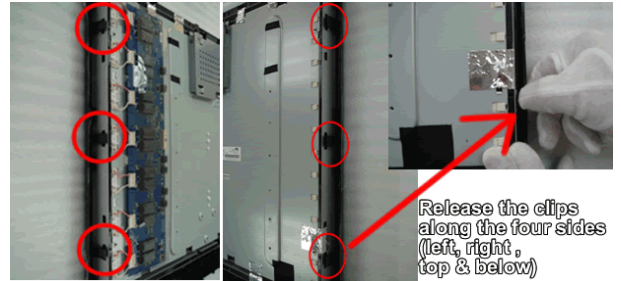

18. When removing the LCD module, you need to pull out both side at the same time to avoid any obstruction.

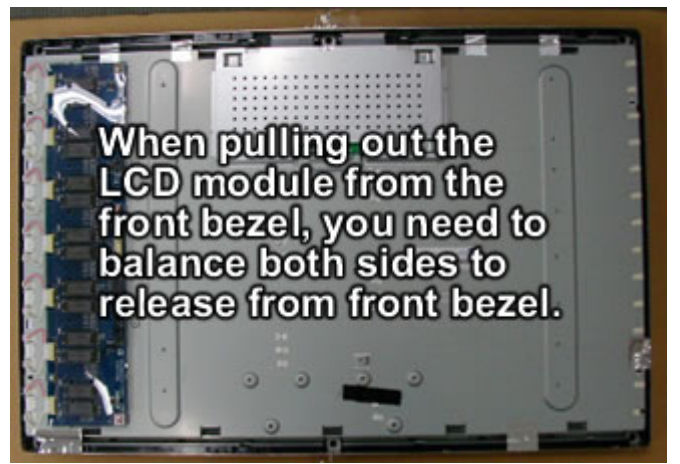

19. Separate the front bezel of the LCD monitor.



20. Unfasten all screws under the shielding.



21. Unfasten all screws on the MB and Power Board and grounding.

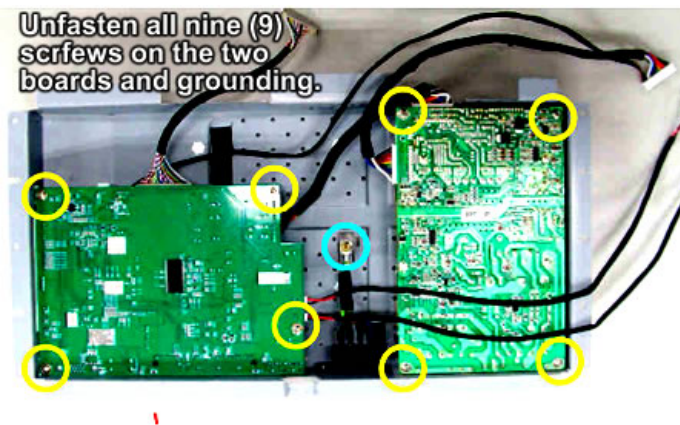

22. You may now separate MB and Power Board

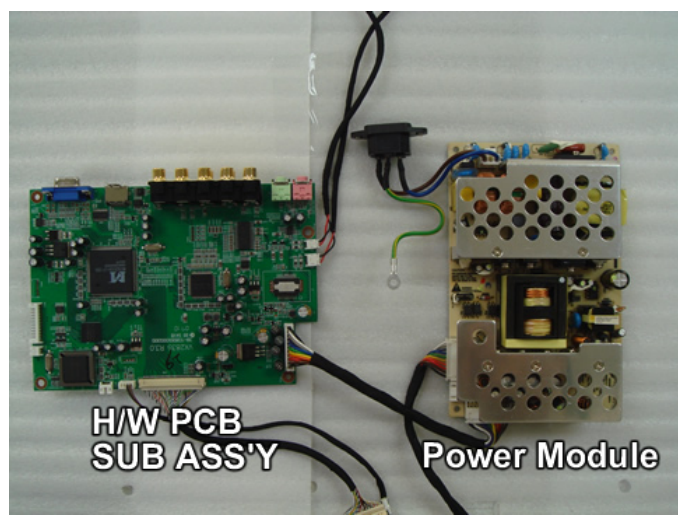

23. The disassembly procedure is done.

NOTE : There might be some additional aluminum foils for EMI solution that are not shown in this procedure.

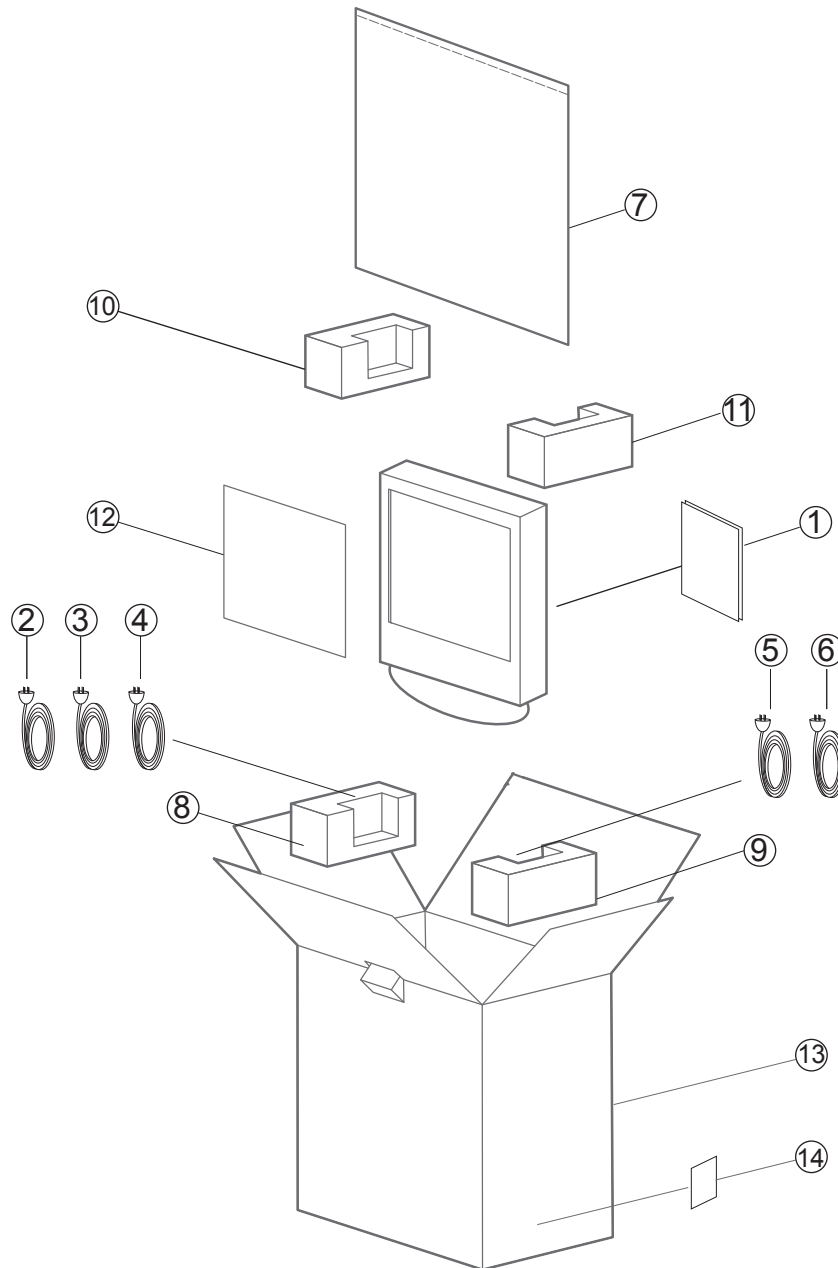

PACKING PART LIST (VX2835wm-1)

ViewSonic Model Number: VS11531

Rev: 1a

Item	ViewSonic P/N	Ref. P/N	Location	Q'ty
1	DC-00008431	72-28350100G310	VX2835wm USA Packing assy,made in Taiwan	1
	N/A	72-28350100G210	VX2835 China packing assy,made in Taiwan	
	DC-00008429	72-28350100G110	VX2835 TWN packing assy,made in Taiwan	
2	CB-00008003	33-00070500G000	CABLE STEREO PHONE SIZE33261B	1
3	N/A	33-Y2830601G200	Cable HDMI To DVI 1.8M(GLET)	1
4	N/A	33-Y2830501G010	Cable SIGNAL CVBS/R/L 1800mm(GLET)	1
5	N/A	33-00000004G000	PWR CORD EUR 250V/10A 1800MM 3C BLK	1
6	CB-00008001	33-00090501G000	CABLE SIGNAL D/15P-15P(M)1800MM	1
7	P-00008486	61-03000017G000	PE Bag,800*1000mm*0.05t	1
8	P-00008485	61-01000065G000	VX2835 END CAP-L-bottom EPS	1
9	P-00008484	61-01000064G000	VX2835 END CAP-R-bottom EPS	1
10	P-00008483	61-01000059G000	VX2835 END CAP-L-top EPS	1
11	P-00008482	61-01000058G000	VX2835 END CAP-R-top EPS	1
12	DC-00008432	42-01120015G000	mylar 394*617*0.1mm for VIEWSONIC 2835	1
13	P-00008481	60-01000117G610	VX2835wm Carton,Taiwan	1
14	N/A	62-06000003G000	BARCODE LABEL 76.2*76.2MM	1

6. Troubleshooting Flow Chart

NO POWER

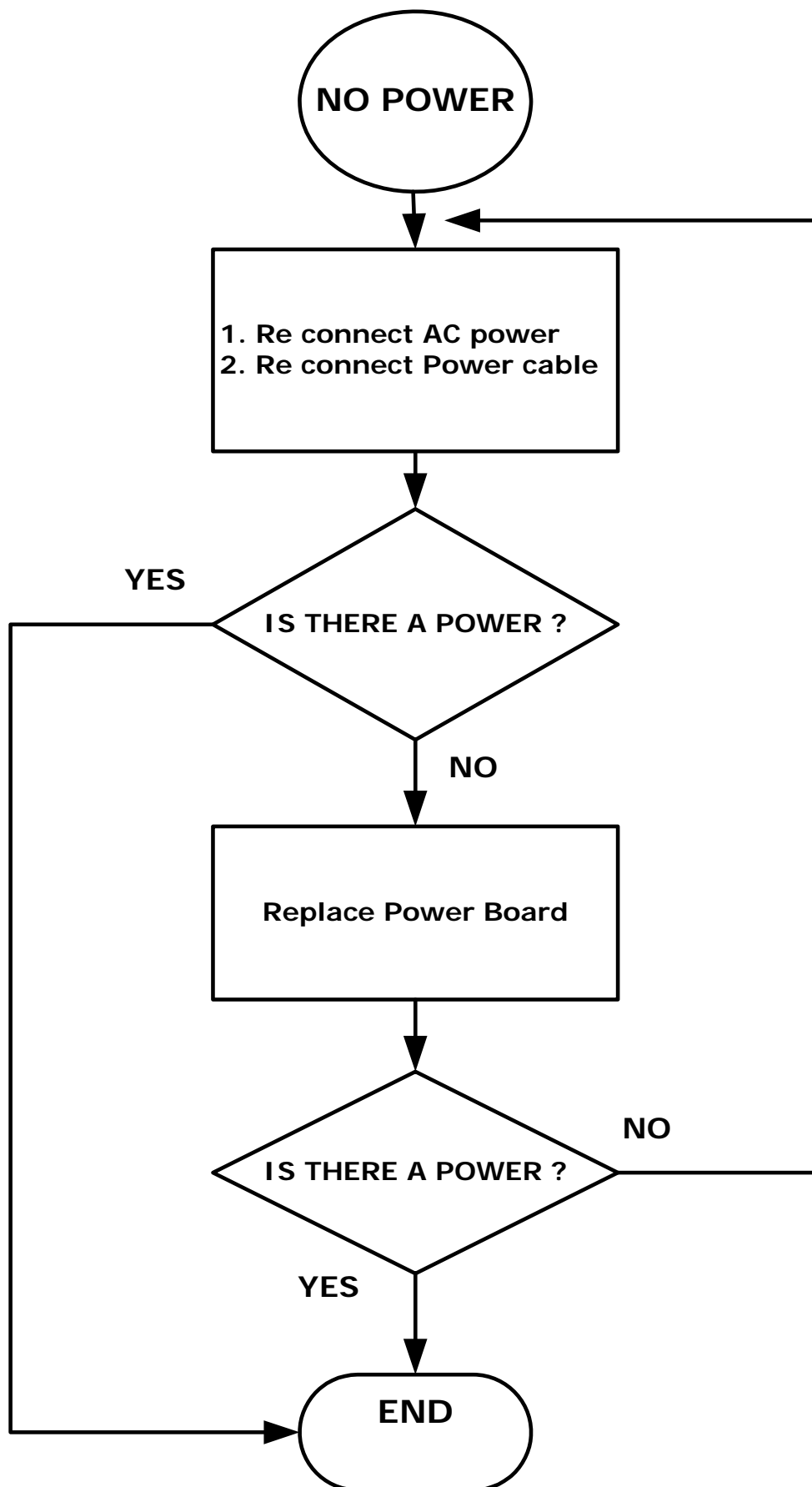

NO DISPLAY

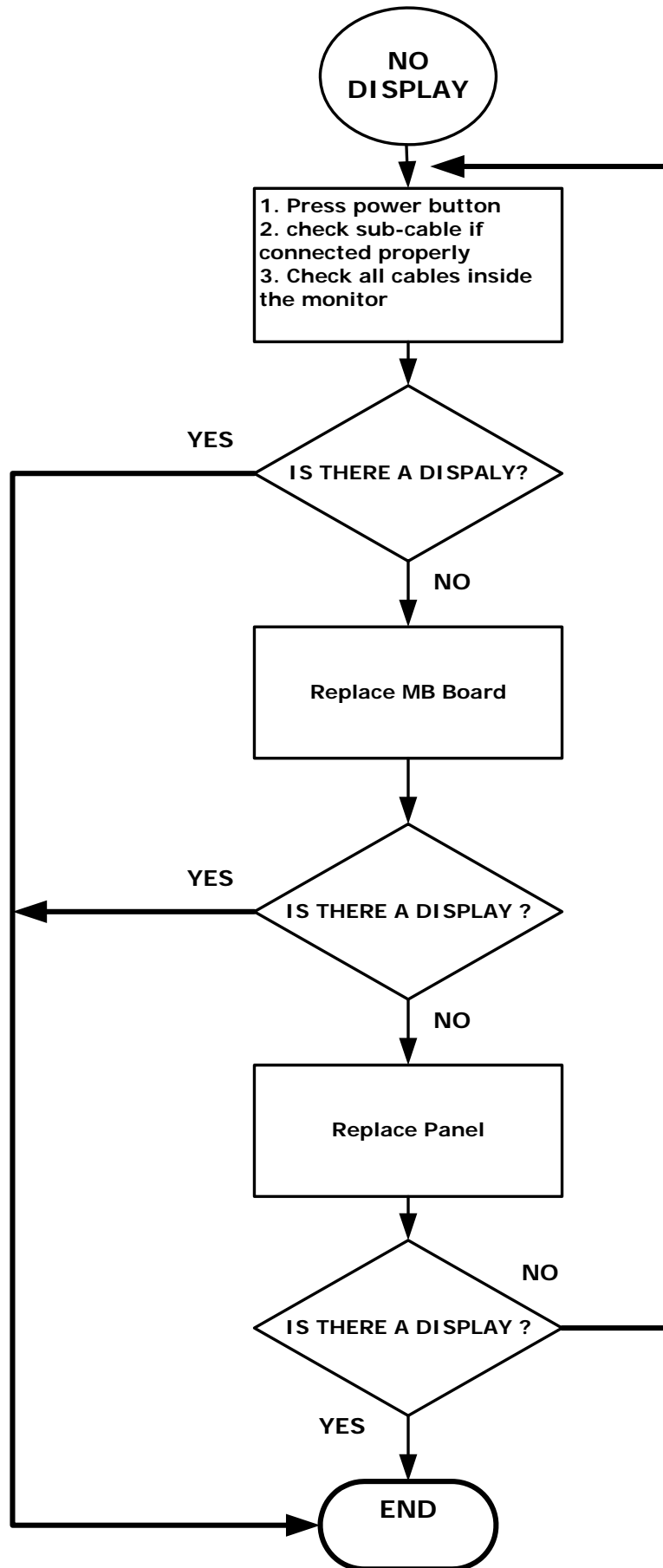

DISPLAY HAVE VERTICAL LINES

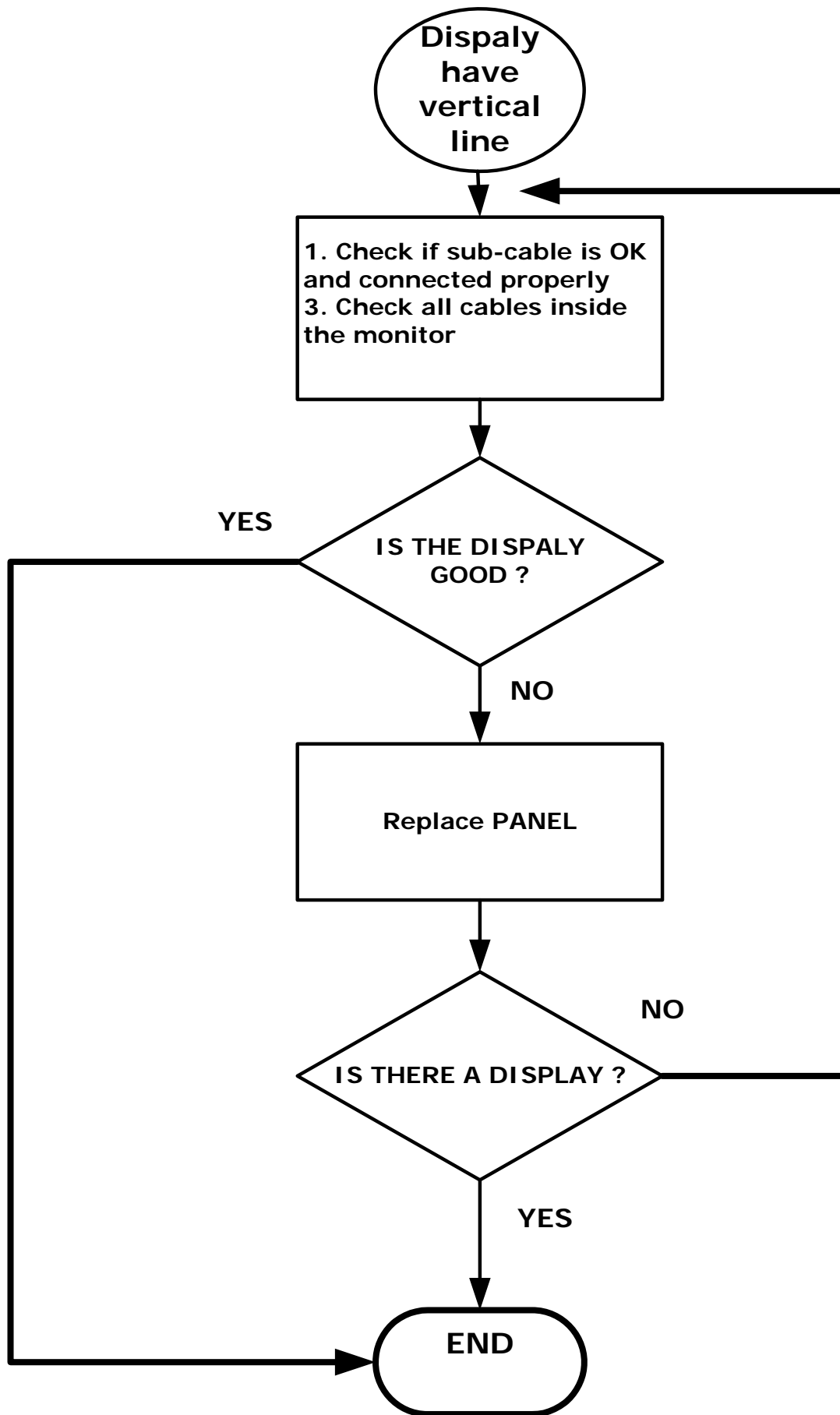

DISPLAY BACKLIGHT IS OFF

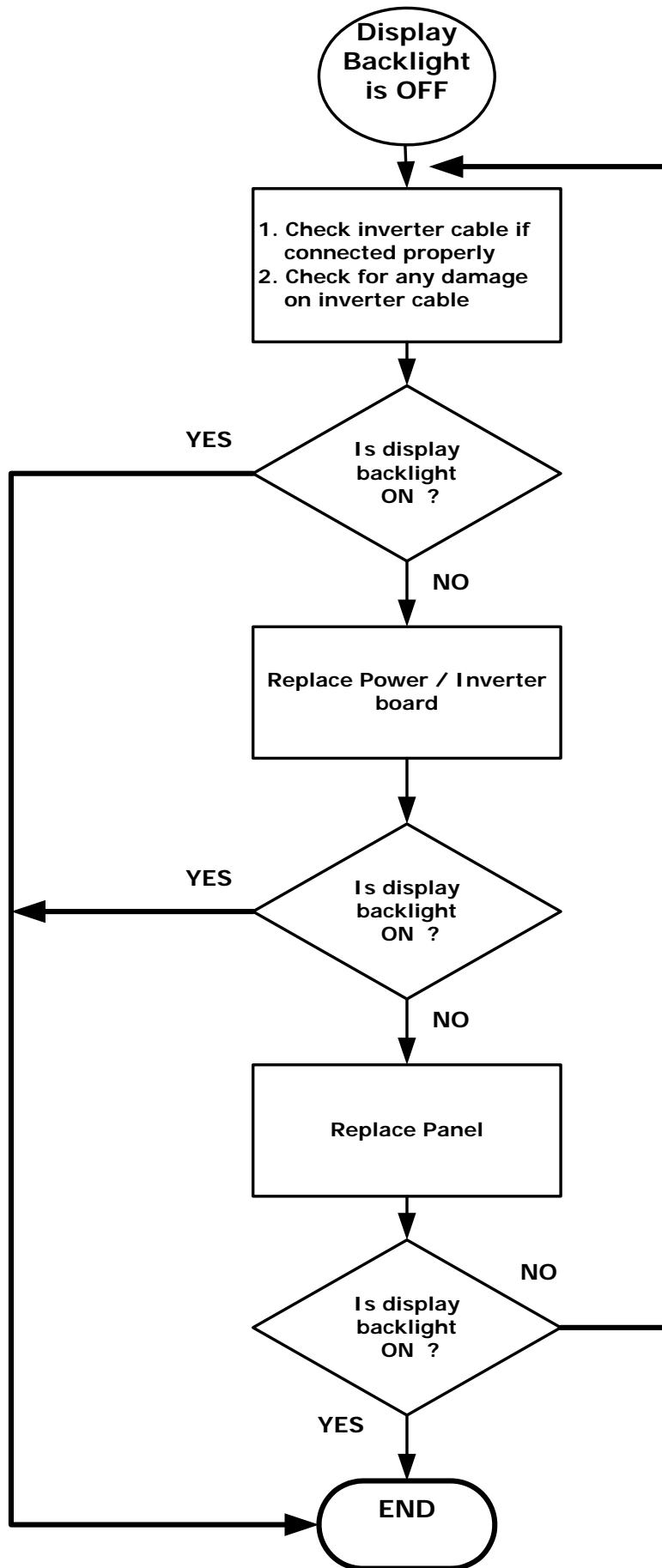

DISPLAY HAVE BLOCK BAR

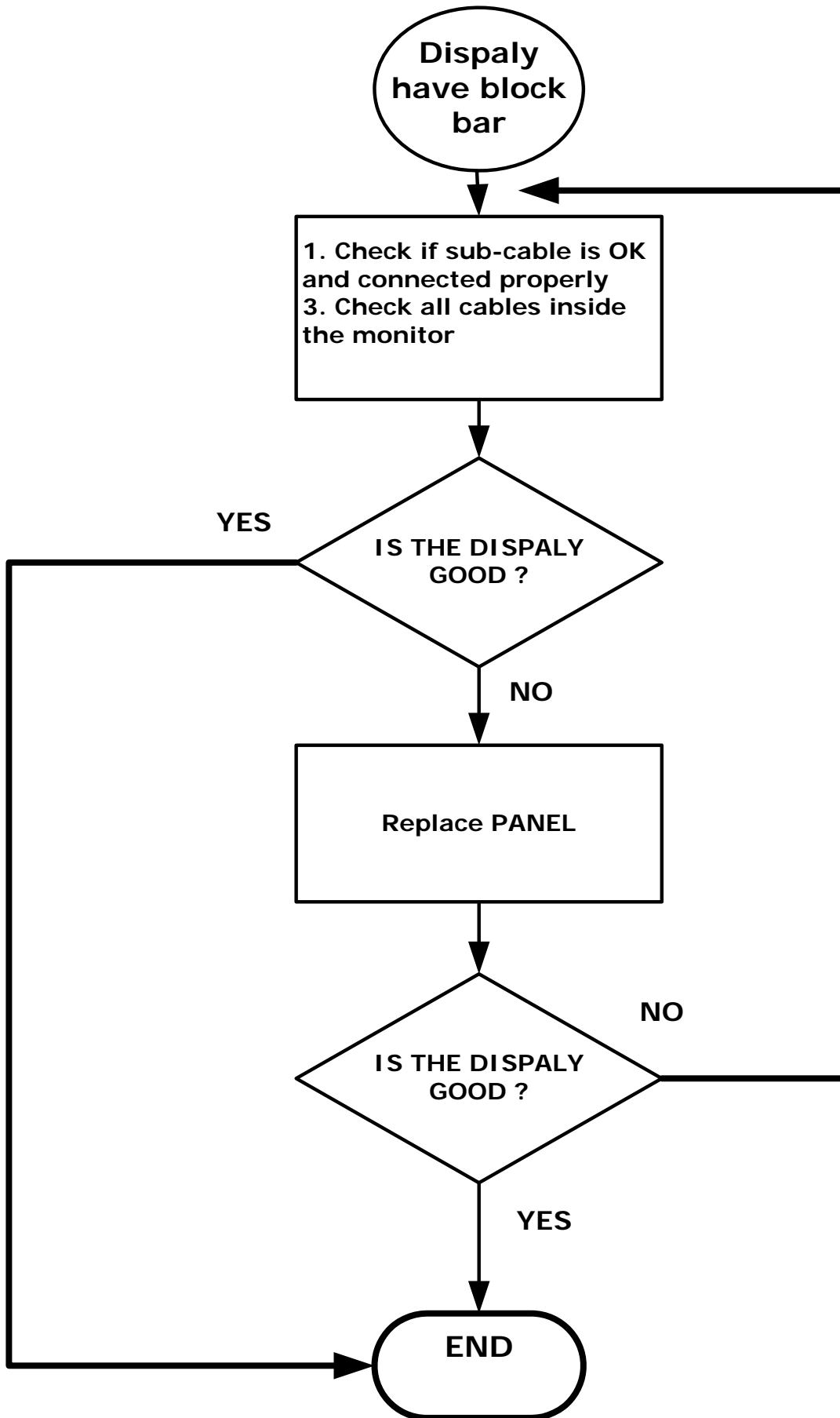

NO AUDIO

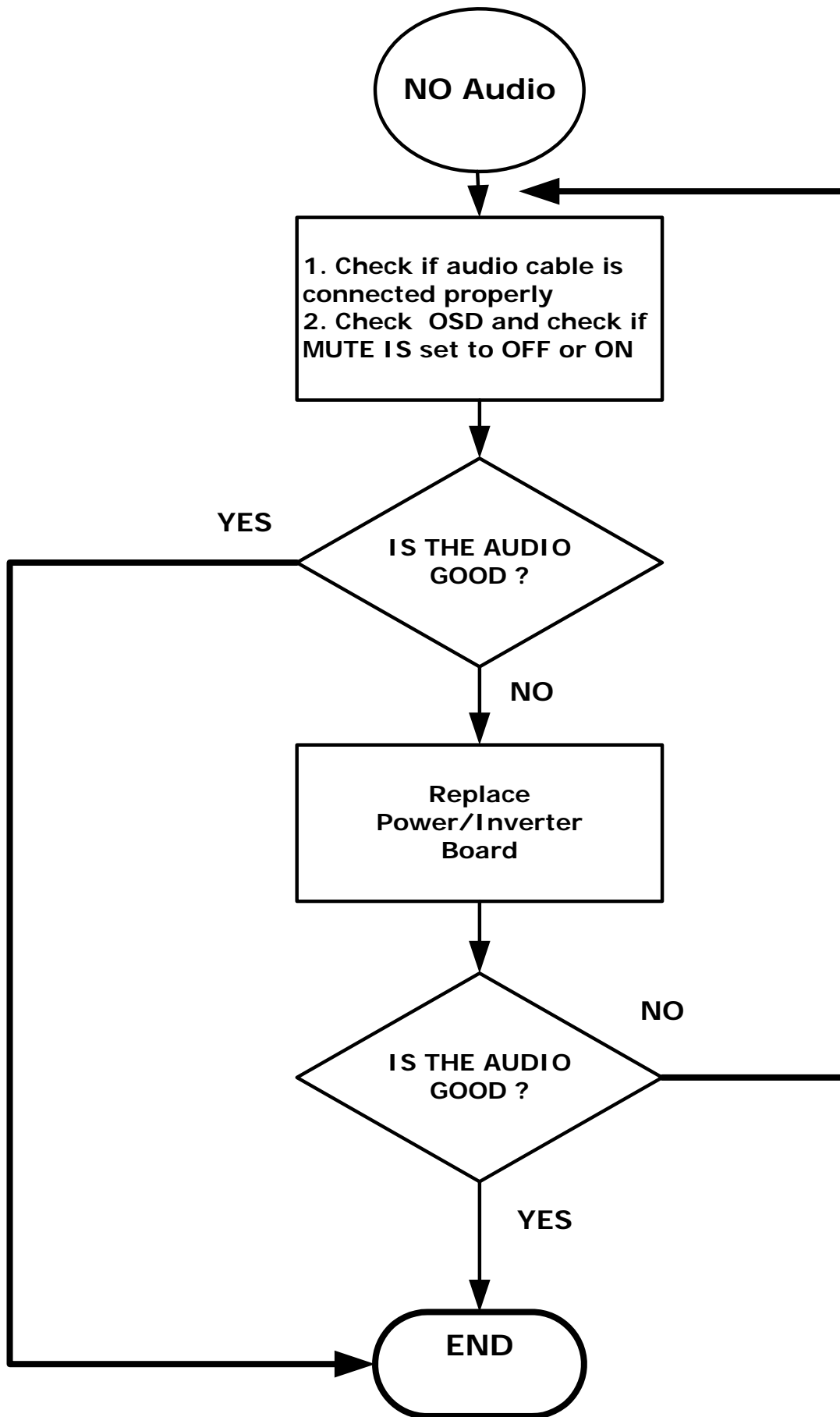

7. Block Diagram

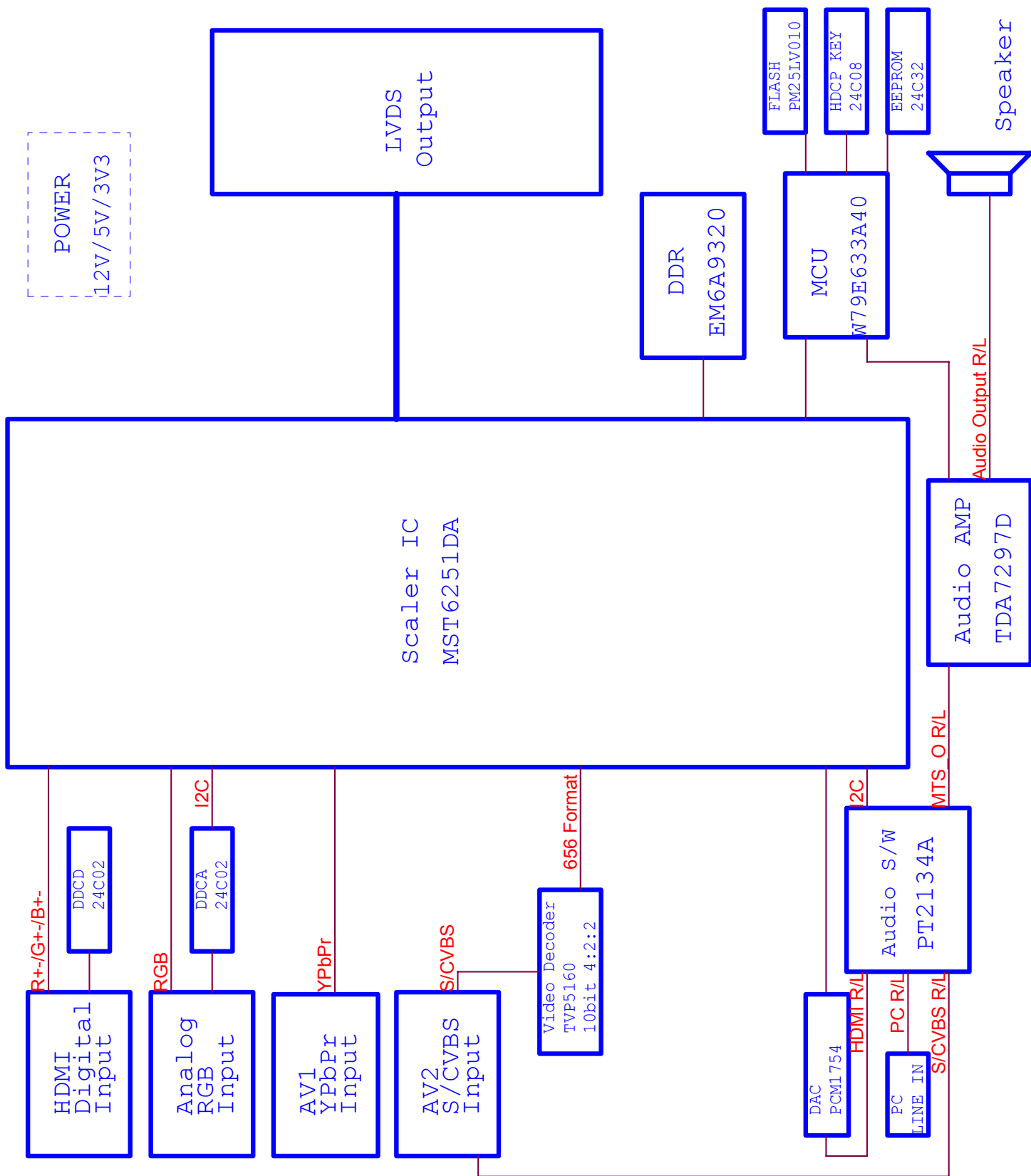

F03 MST6251DA SCHEMATIC

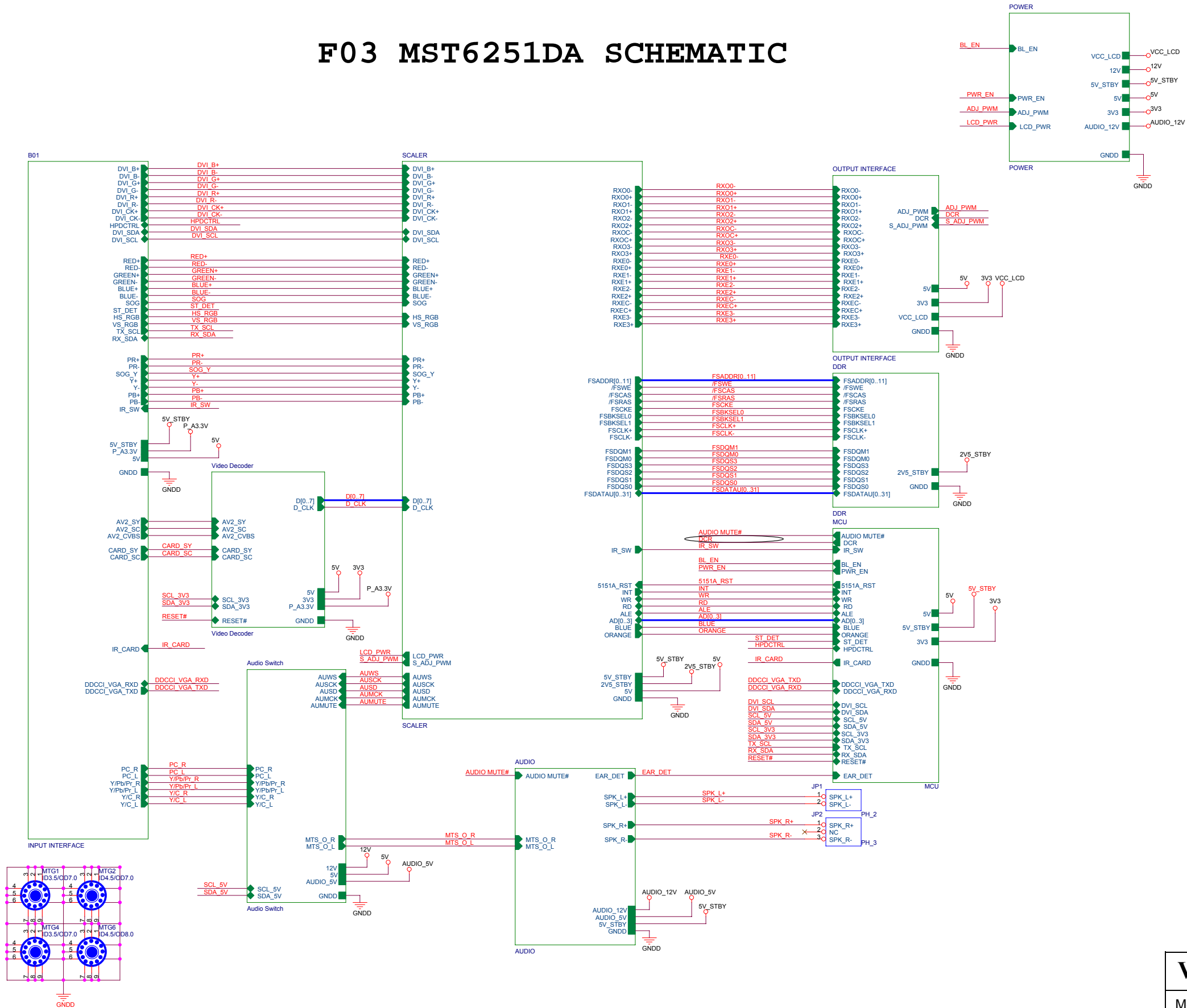

ViewSonic Corporation	
Model	
Title	SCALER
Date	Rev:

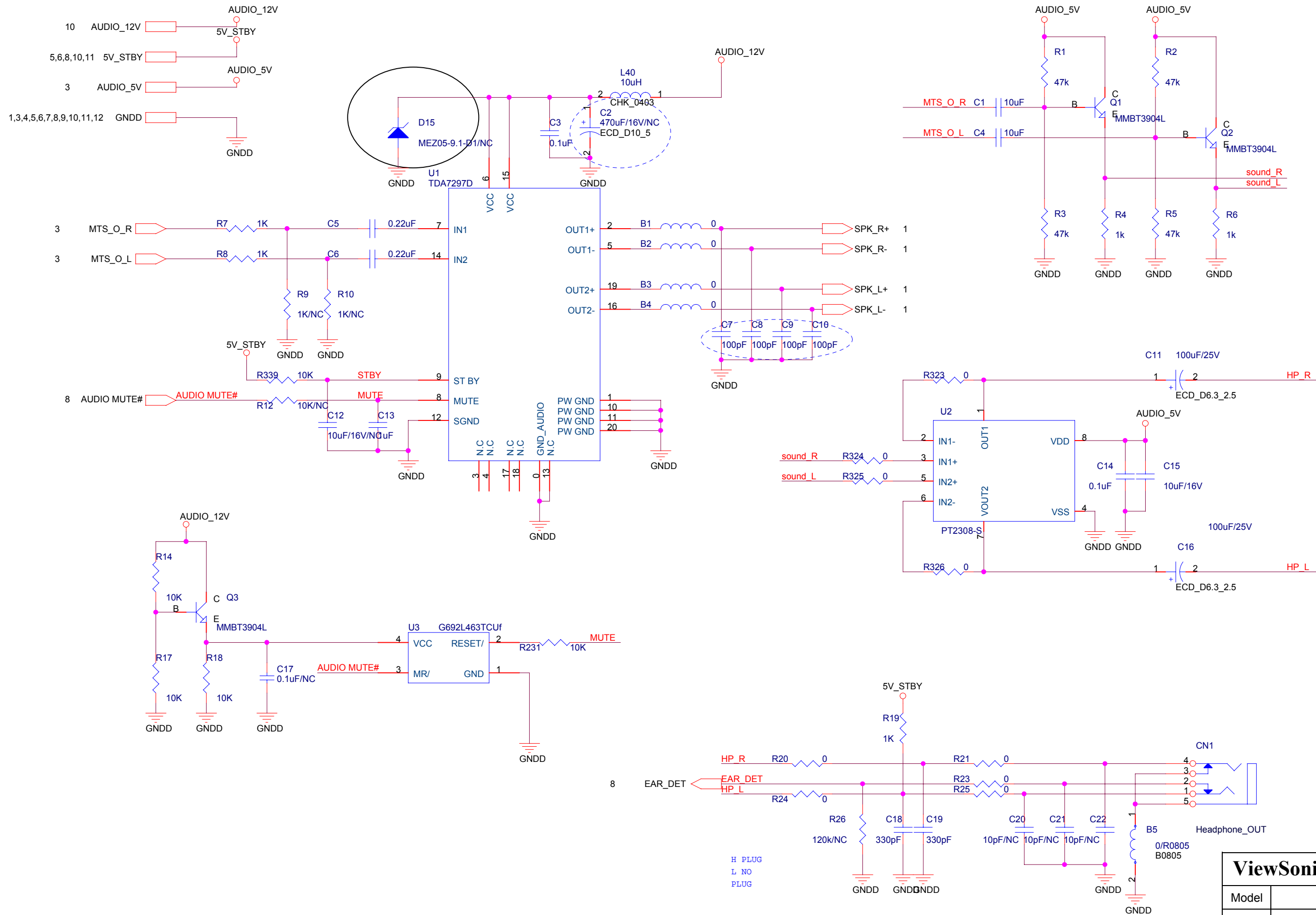

ViewSonic Corporation	
Model	
Title	SCALER
Date	
	Rev:

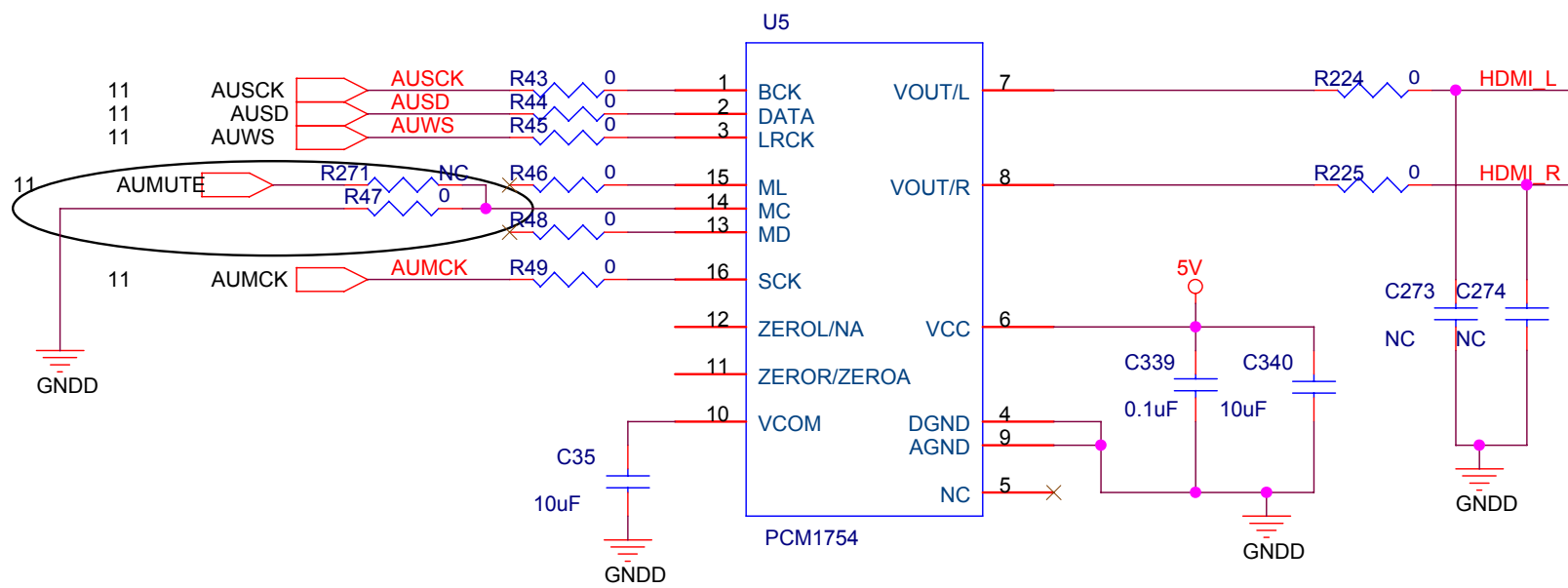
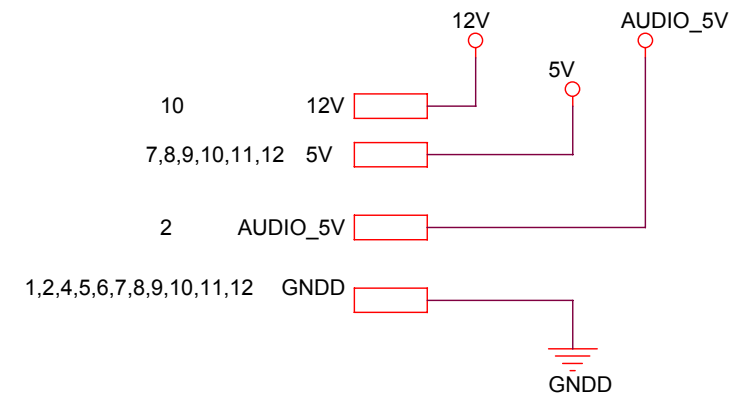
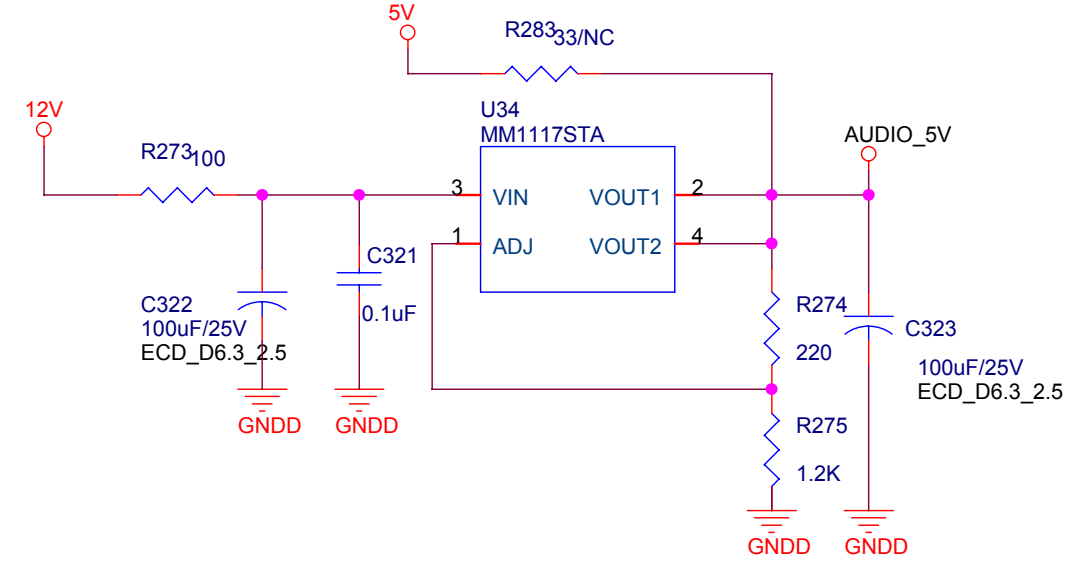
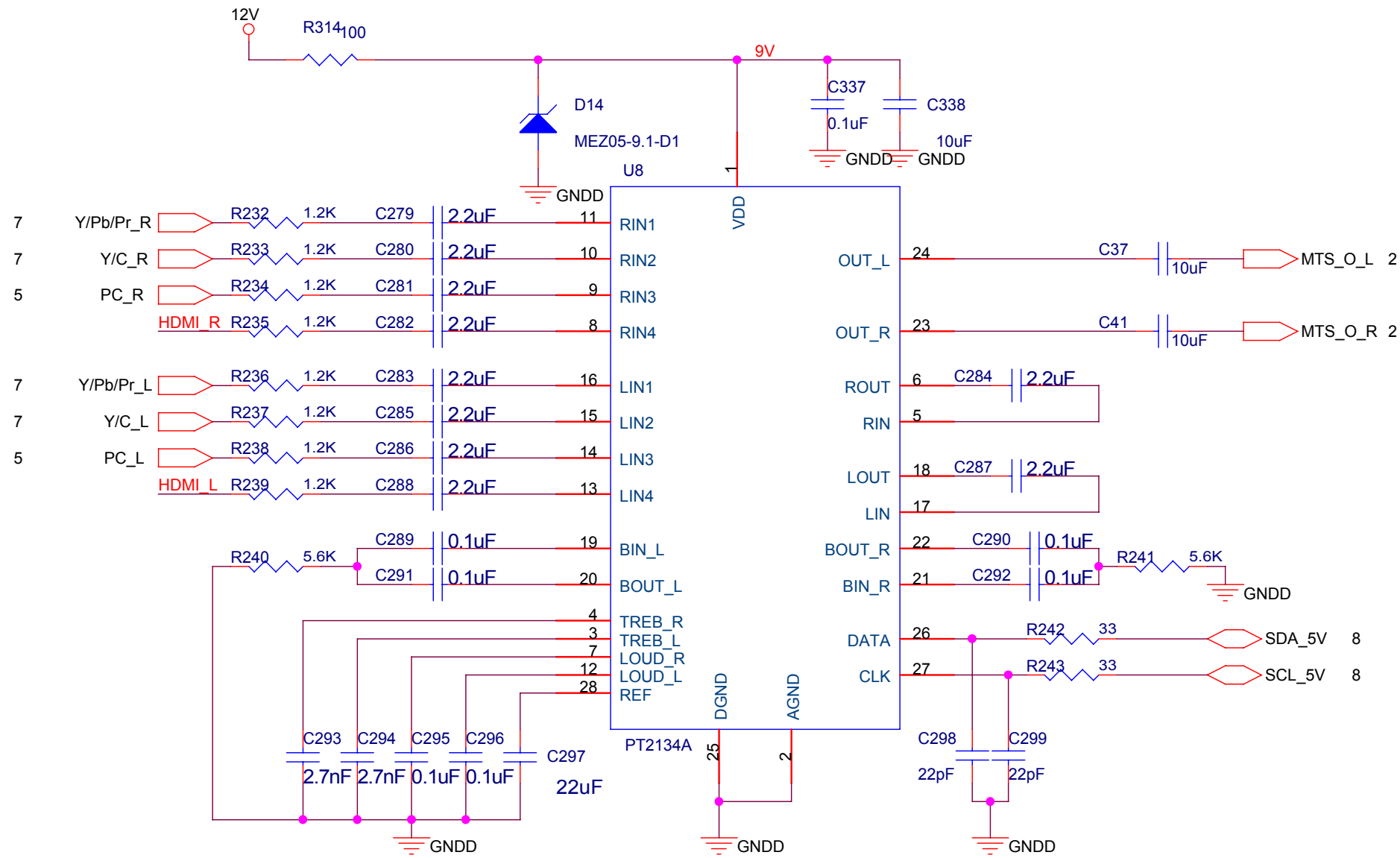

ViewSonic Corporation	
Model	
Title	SCALER
Date	Rev:

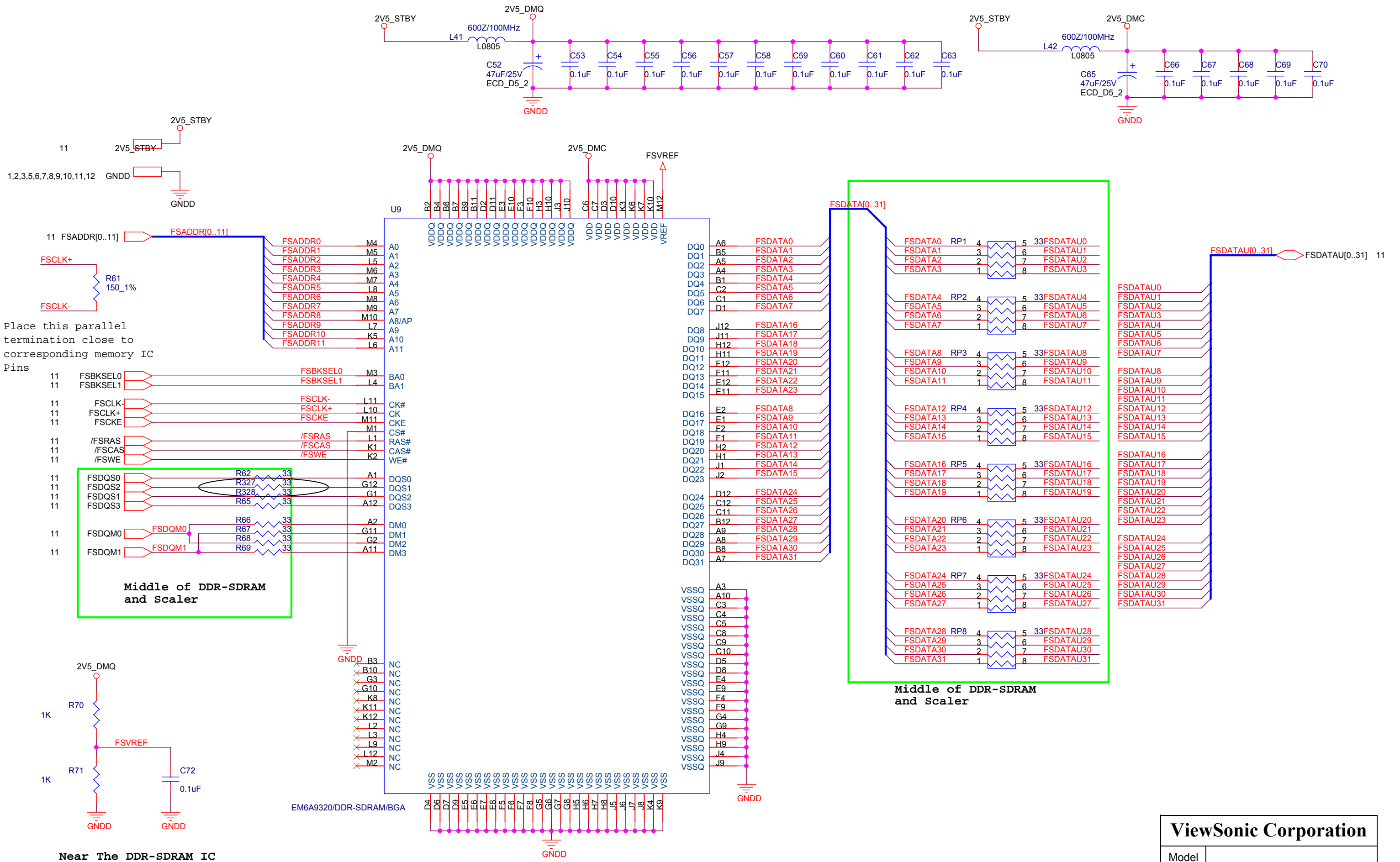

Place this parallel termination close to corresponding memory IC

Pins

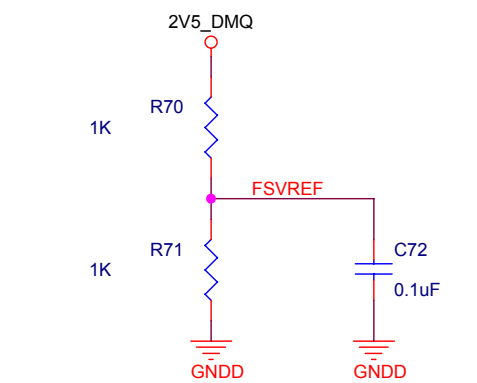
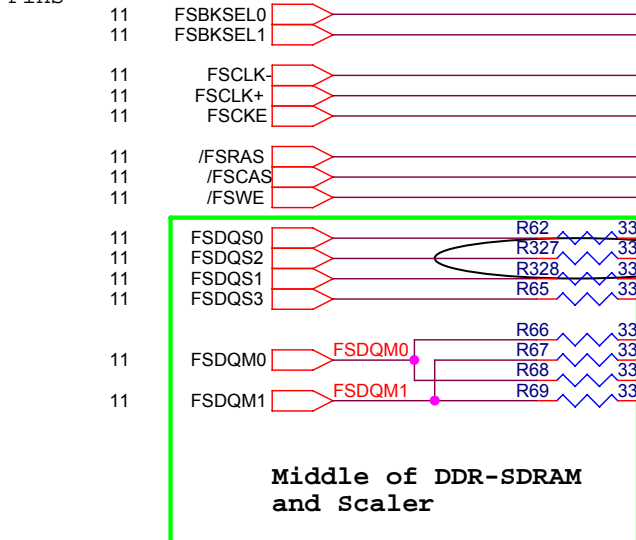

Near The DDR-SDRAM IC

ViewSonic Corporation	
Model	
Title	SCALER
Date	Rev:

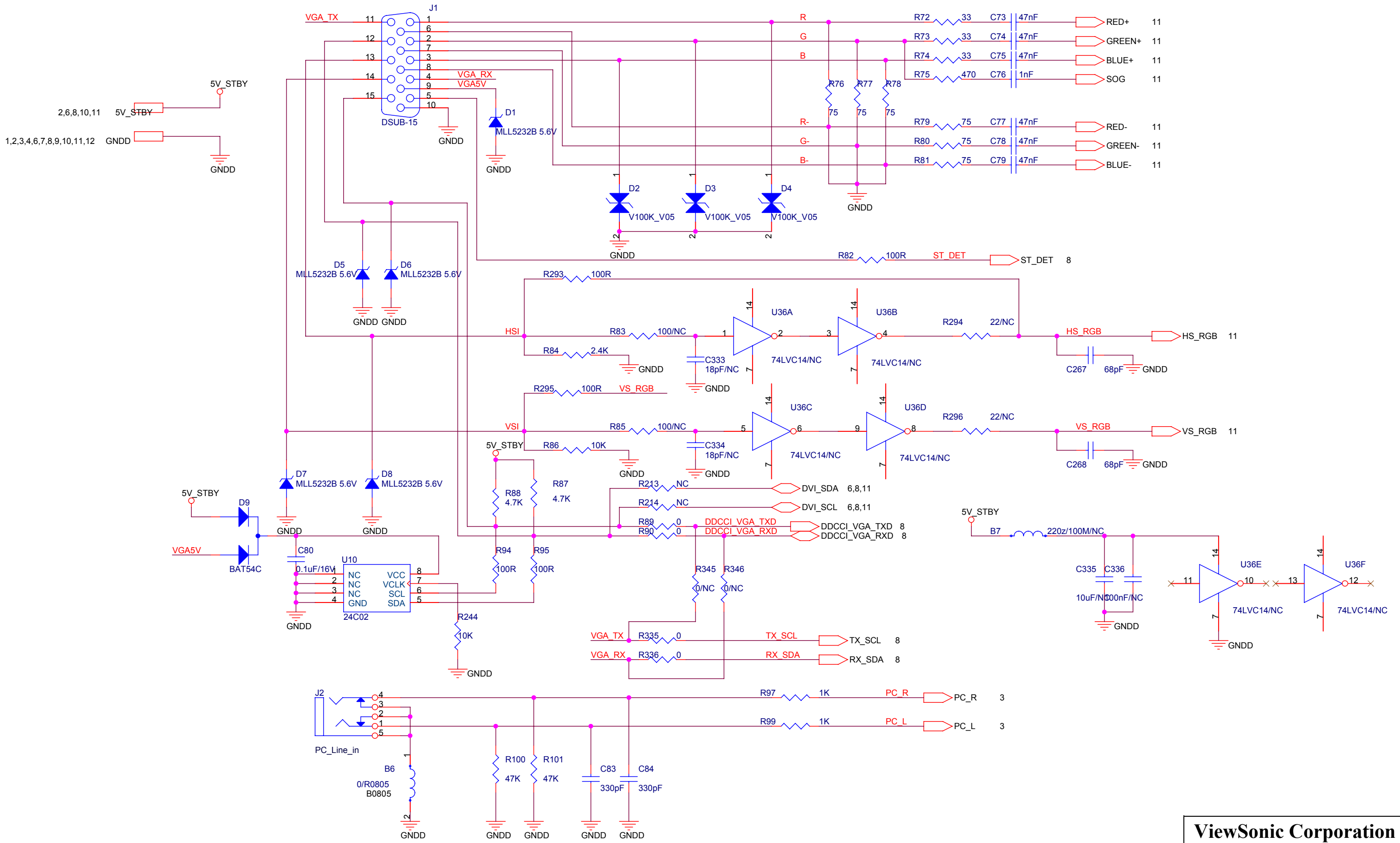

ViewSonic Corporation	
Model	
Title	SCALER
Date	Rev:

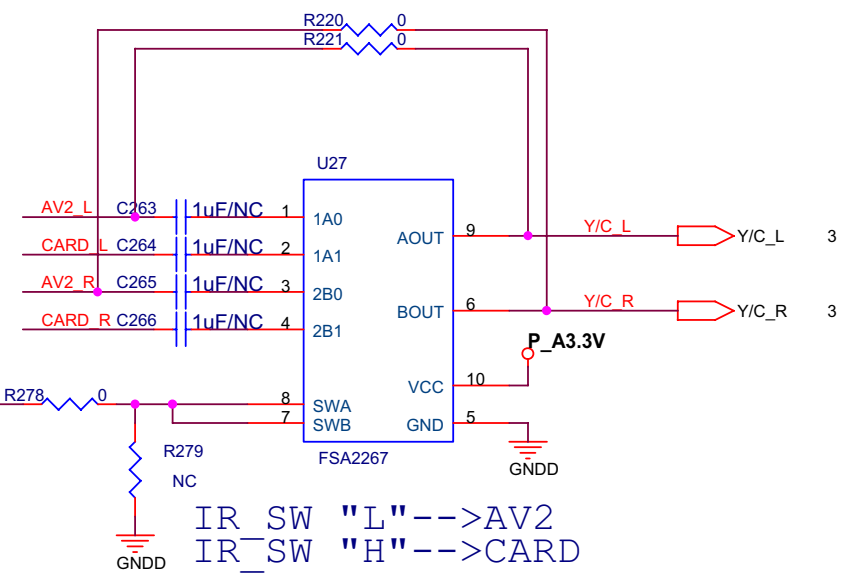
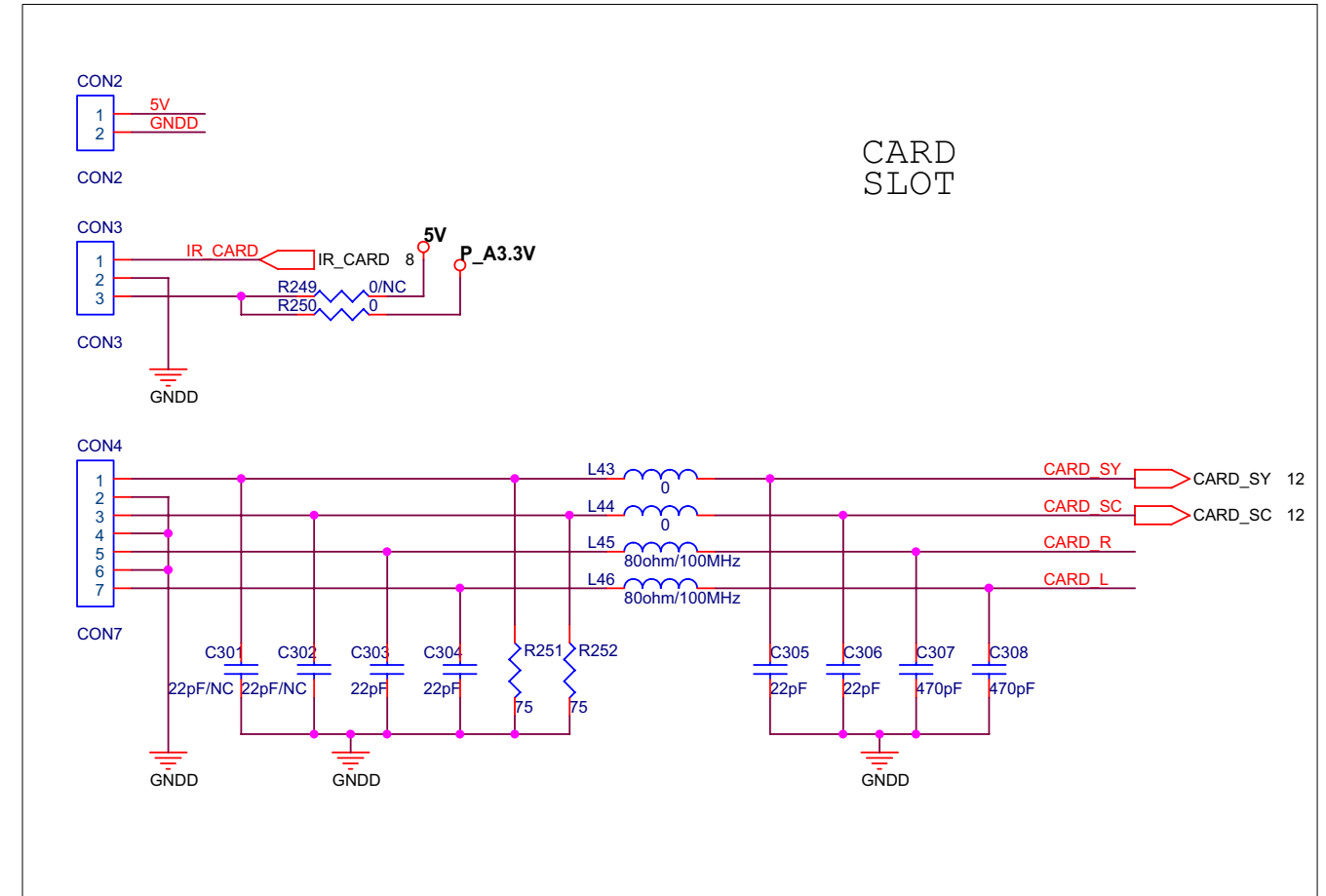
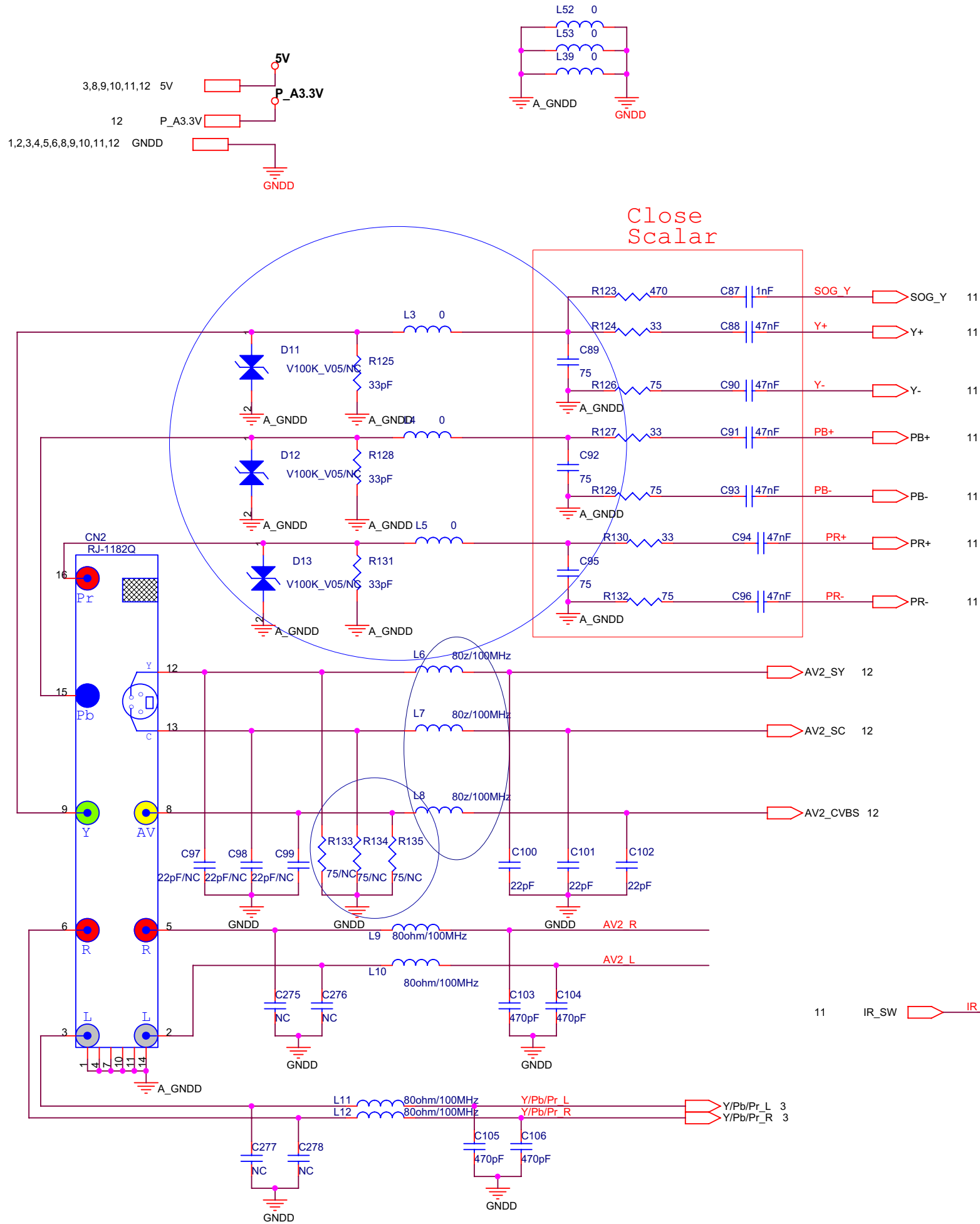

ViewSonic Corporation	
Model	
Title	SCALER
Date	Rev:

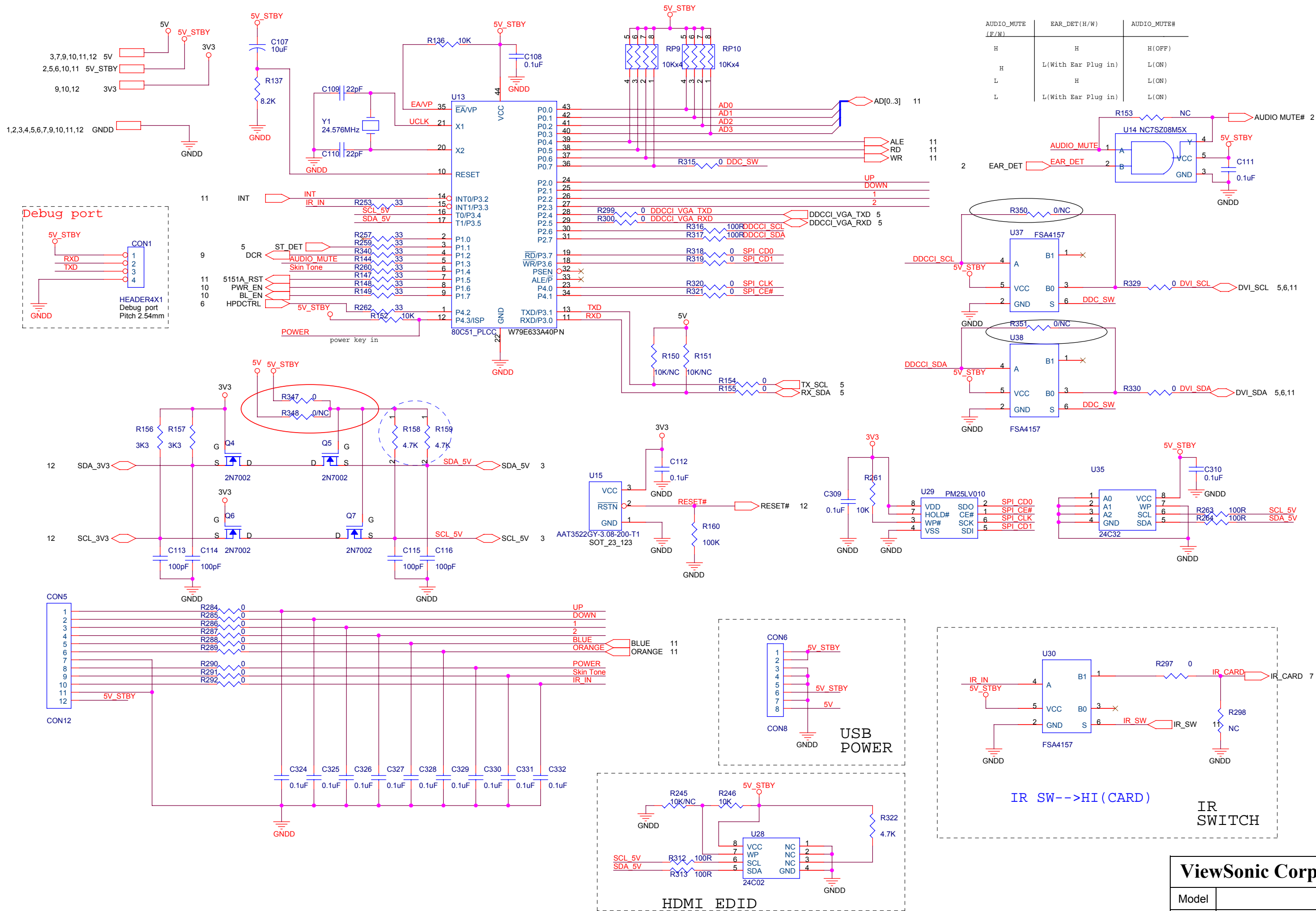

AUDIO_MUTE (F/W)	EAR_DET(H/W)	AUDIO_MUTE#
H	H	H(OFF)
H	L(With Ear Plug in)	L(ON)
L	H	L(ON)
L	L(With Ear Plug in)	L(ON)

ViewSonic Corporation		
Model		
Title	SCALER	
Date		Rev:

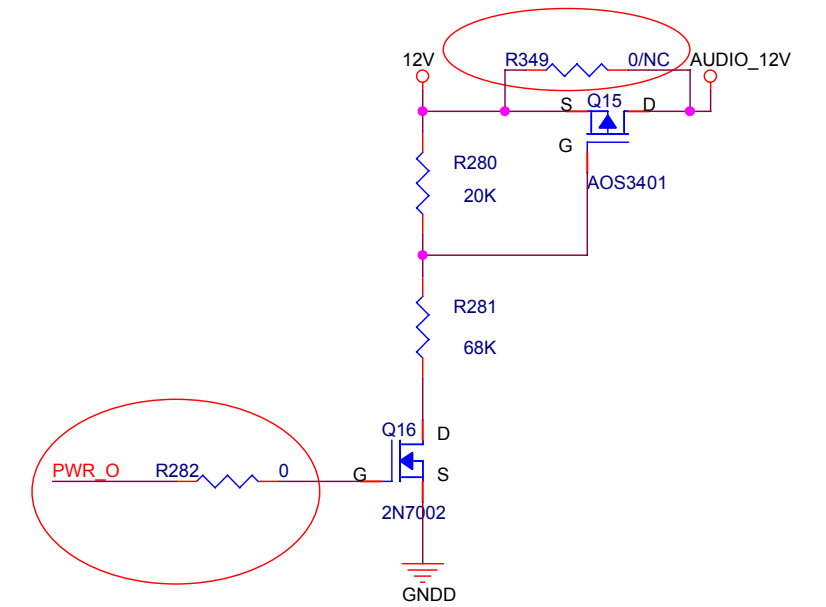
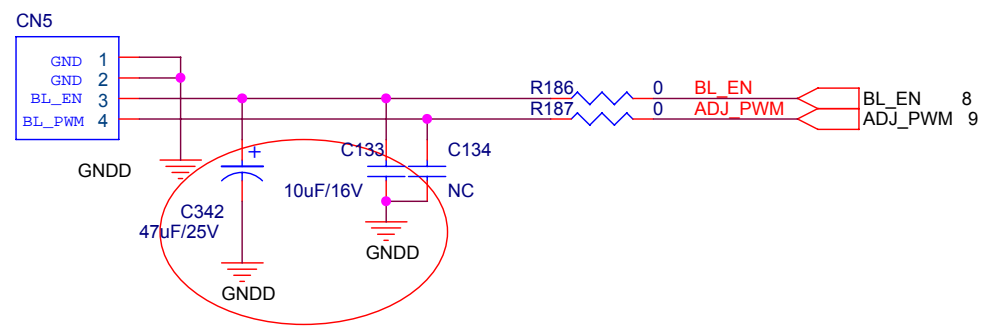
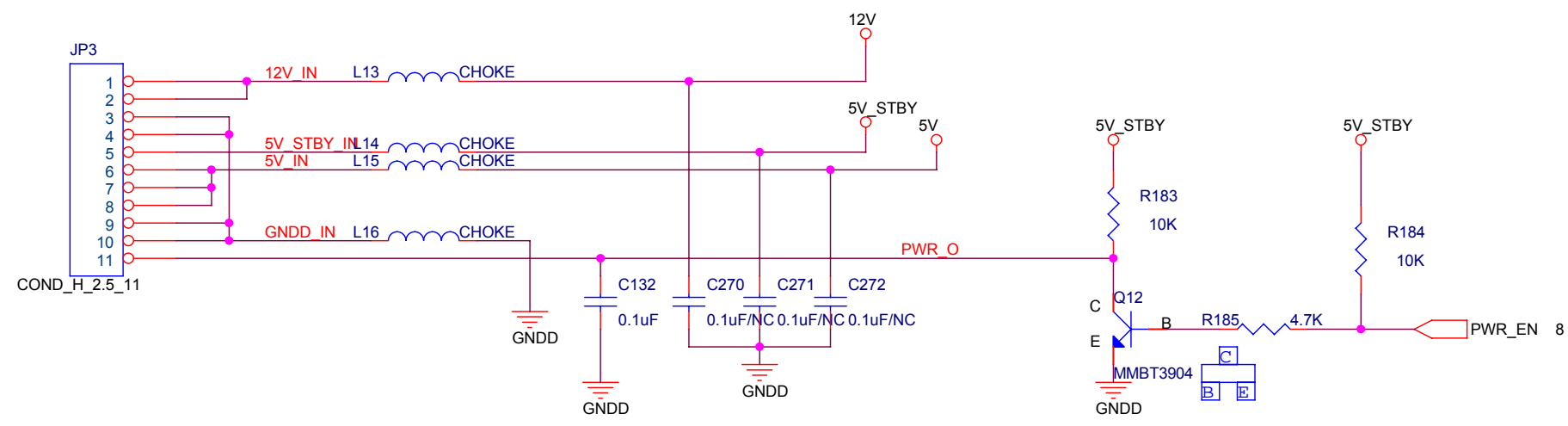
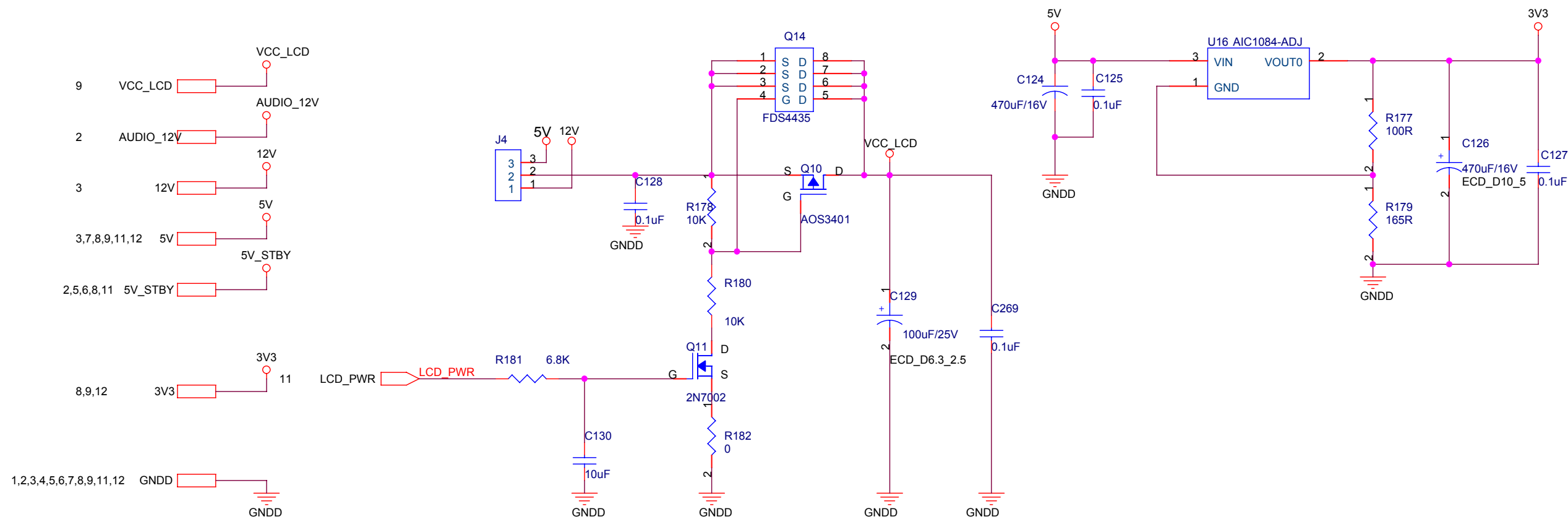

ViewSonic Corporation	
Model	
Title	SCALER
Date	Rev:

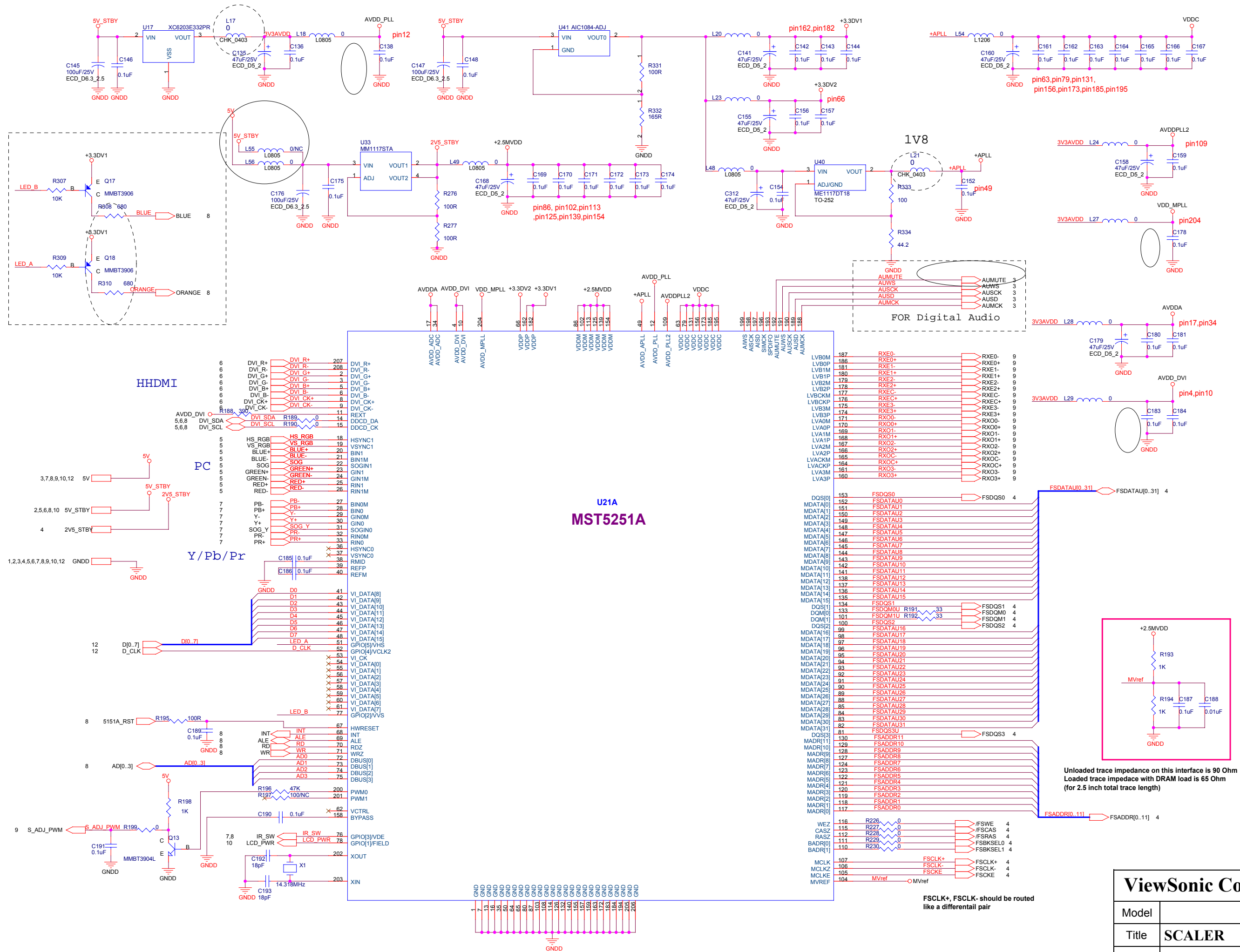

Unloaded trace impedance on this interface is 90 Ohm
Loaded trace impedance with DRAM load is 65 Ohm
(for 2.5 inch total trace length)

FCLK+, FCLK- should be routed like a differential pair

ViewSonic Corporation	
Model	SCALER
Title	SCALER
Date	Rev:

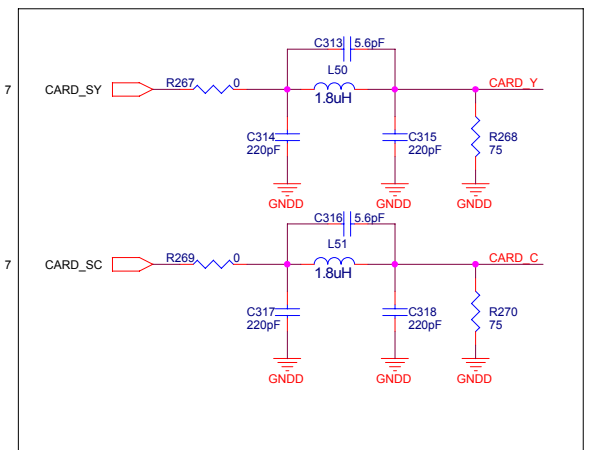
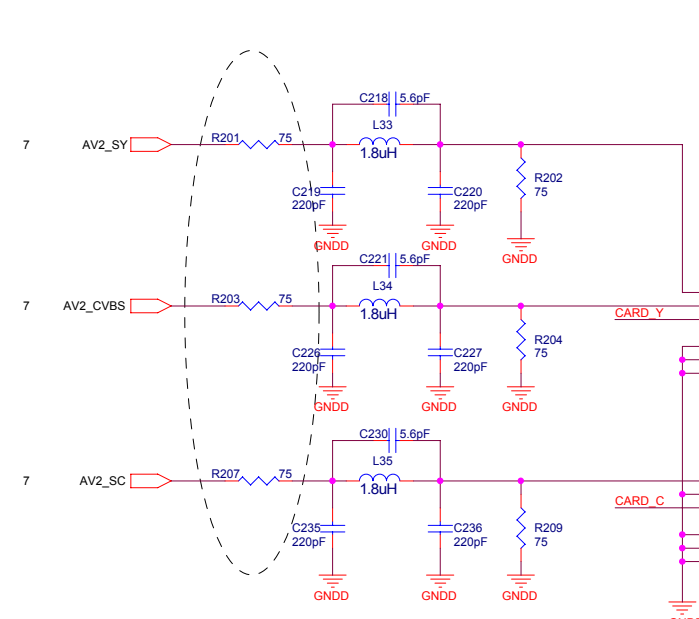
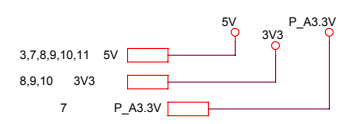
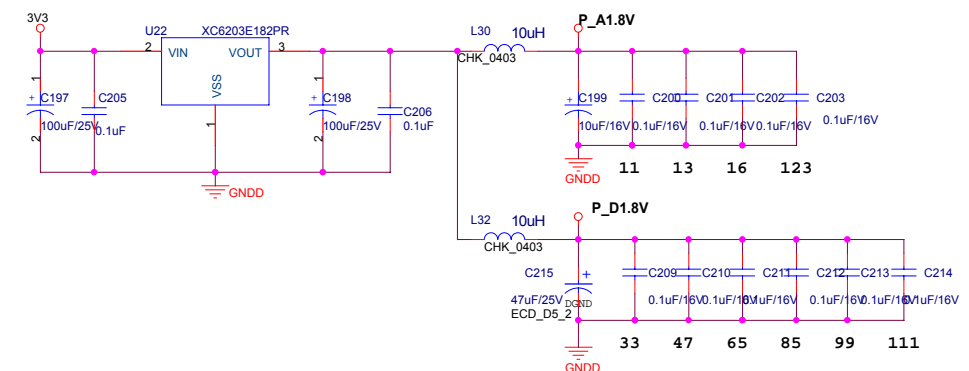
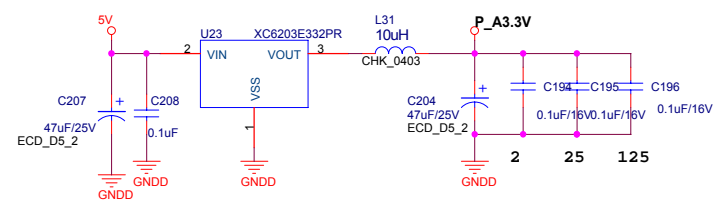

1. Analog Channel Video Model Selection following up the Datasheet Page 44 .
 2. Must considered your Video Input Connector in layout Side, To avoid Trace Cross in PCB.

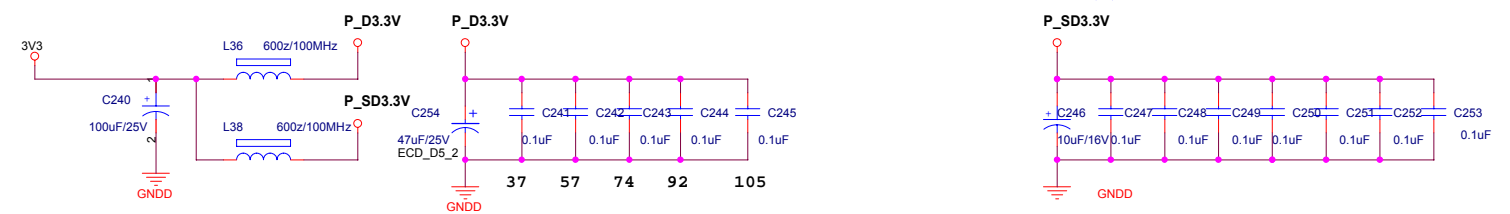
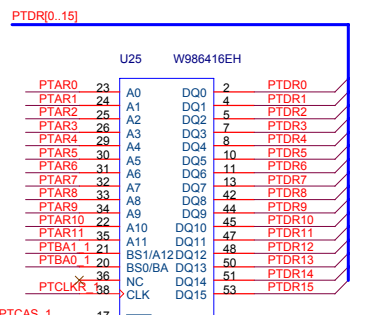
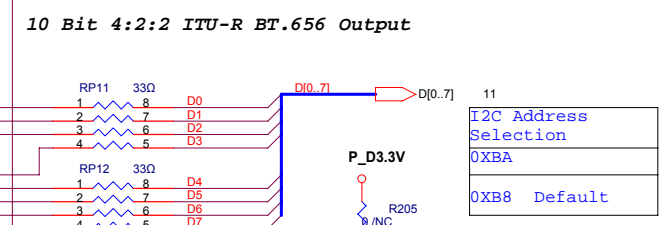
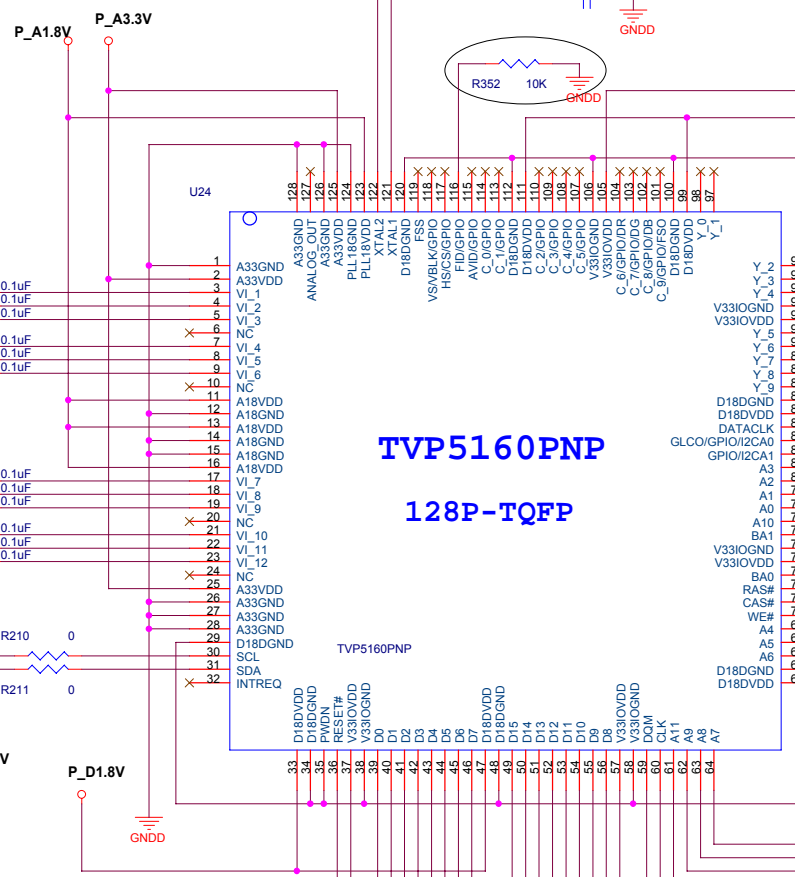

ViewSonic Corporation	
Model	
Title	SCALER
Date	Rev:

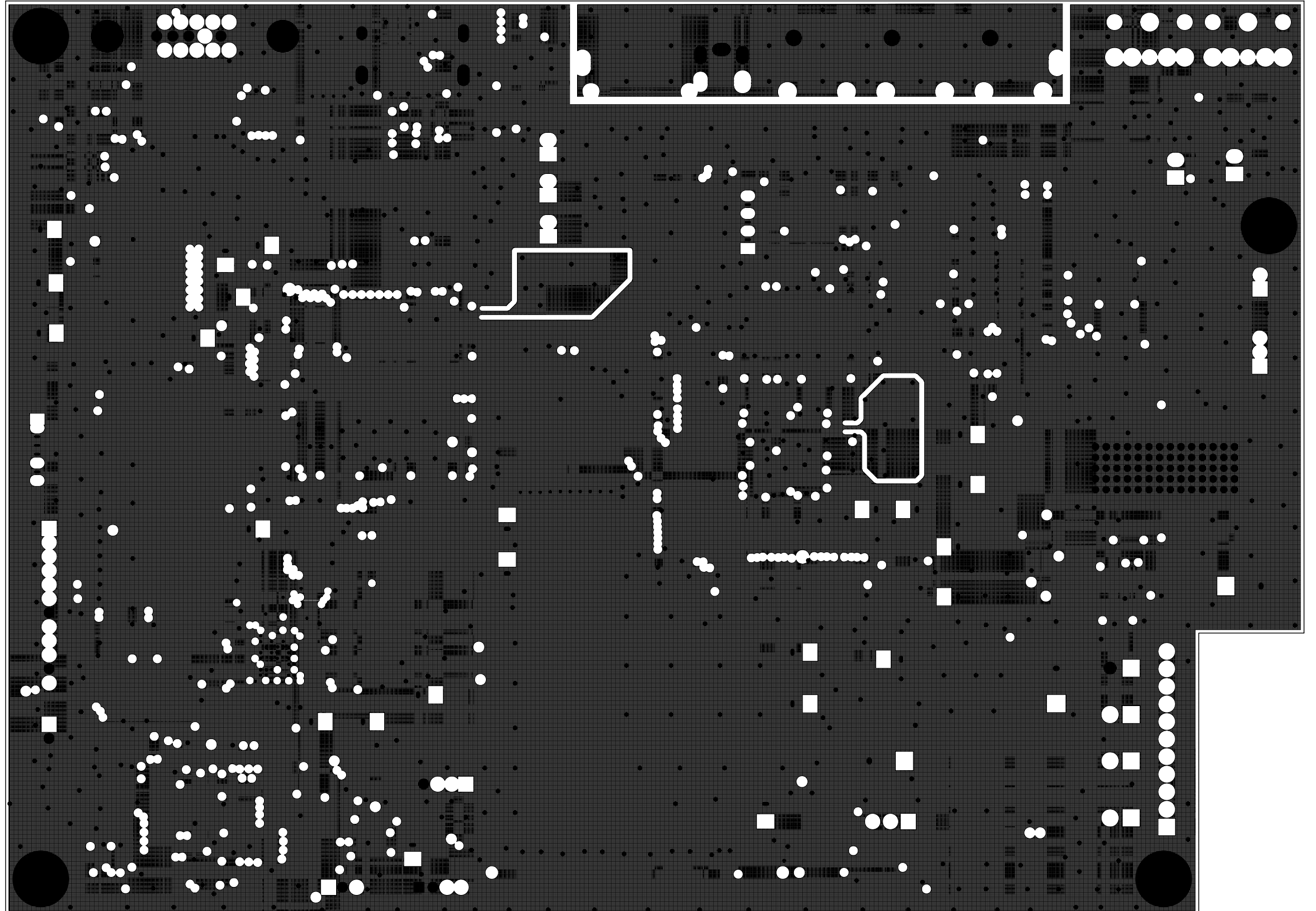

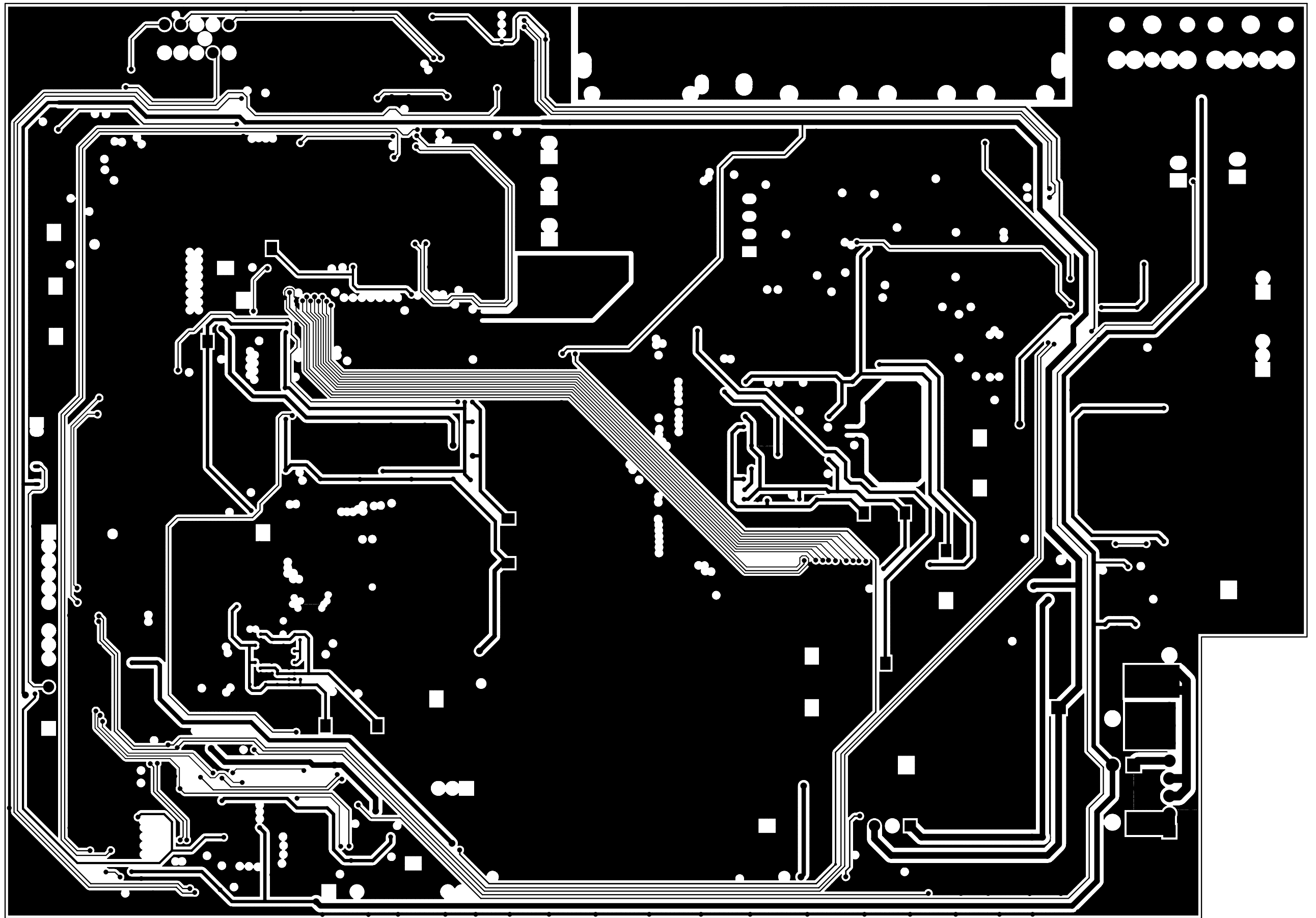

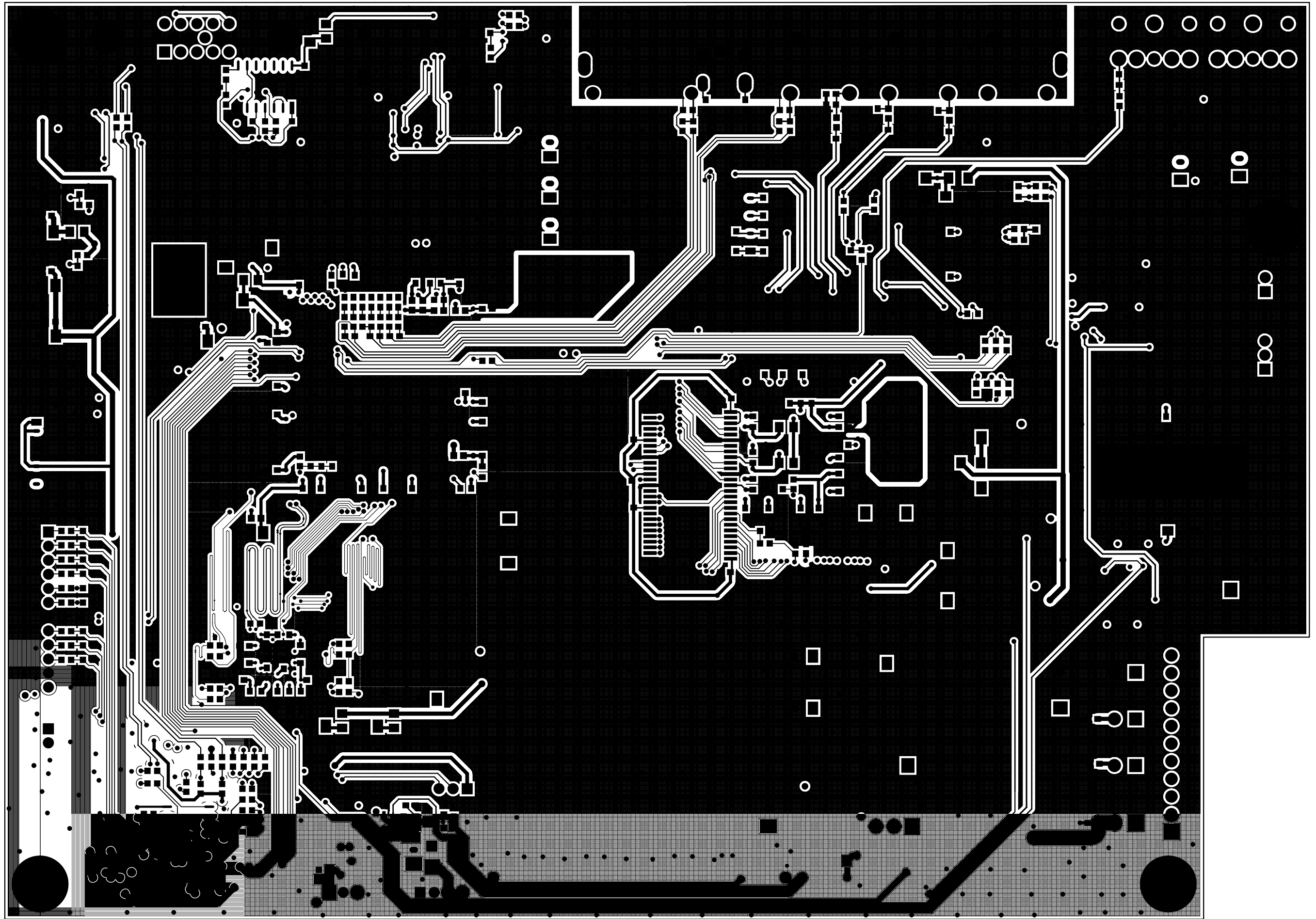

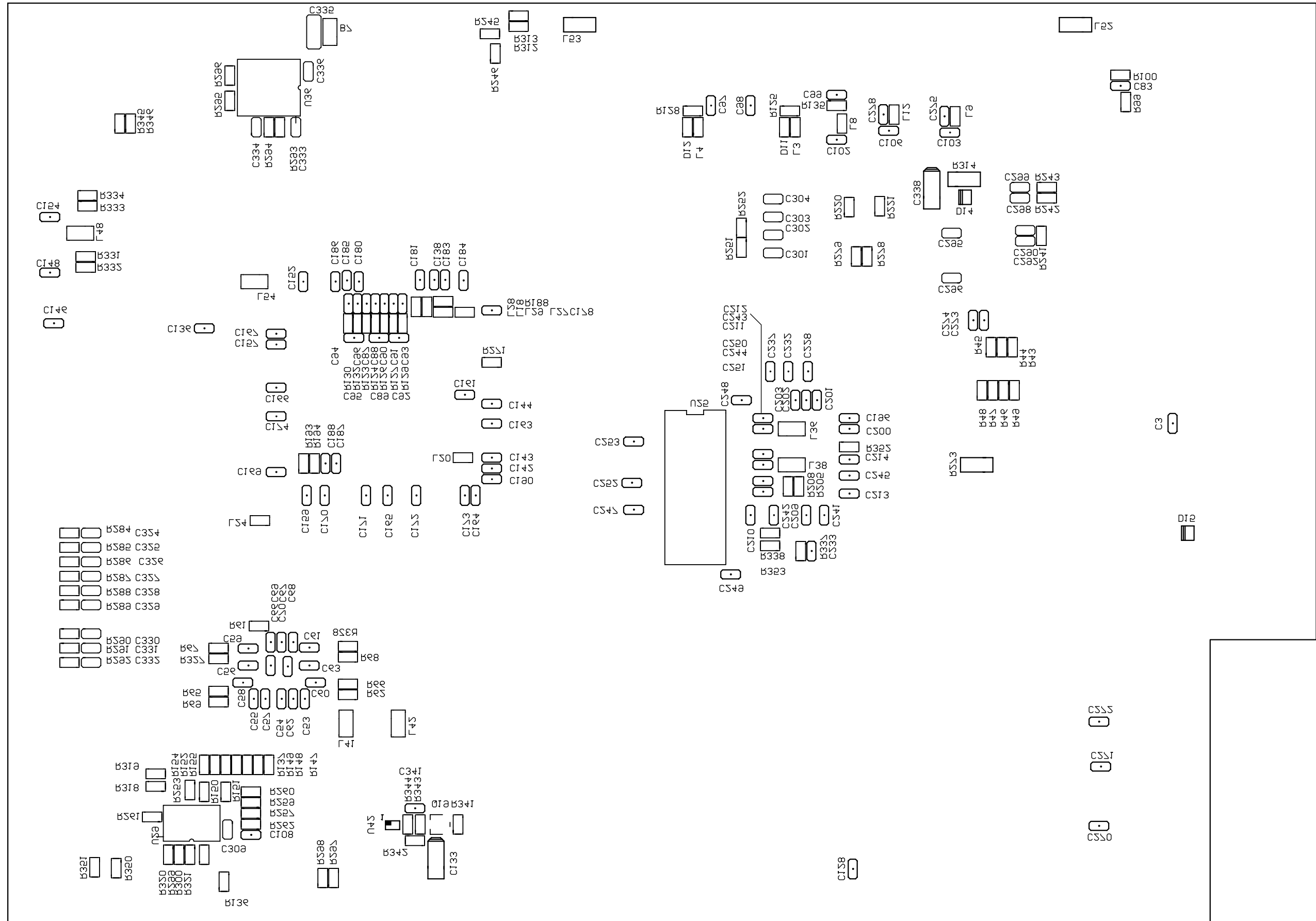

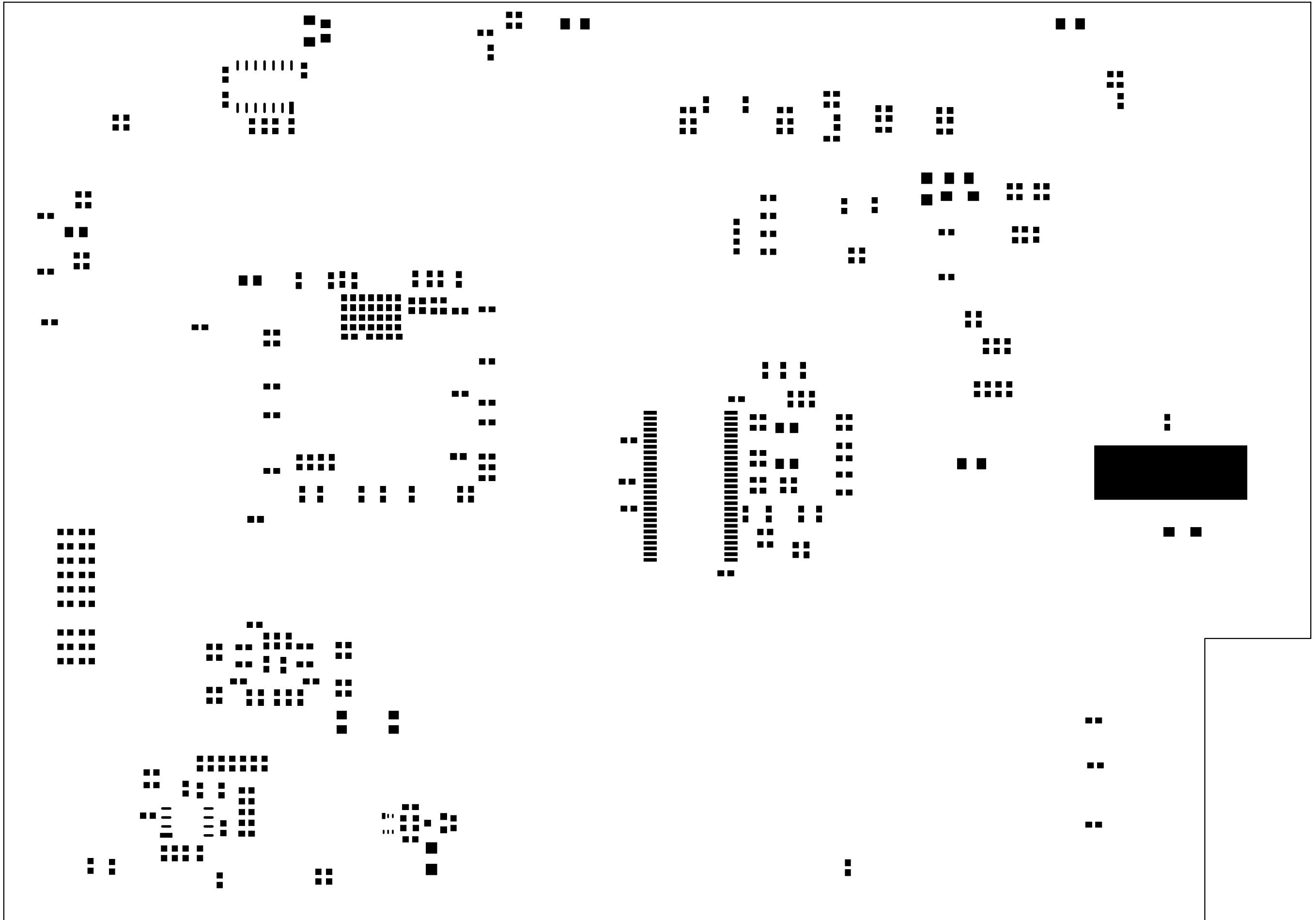

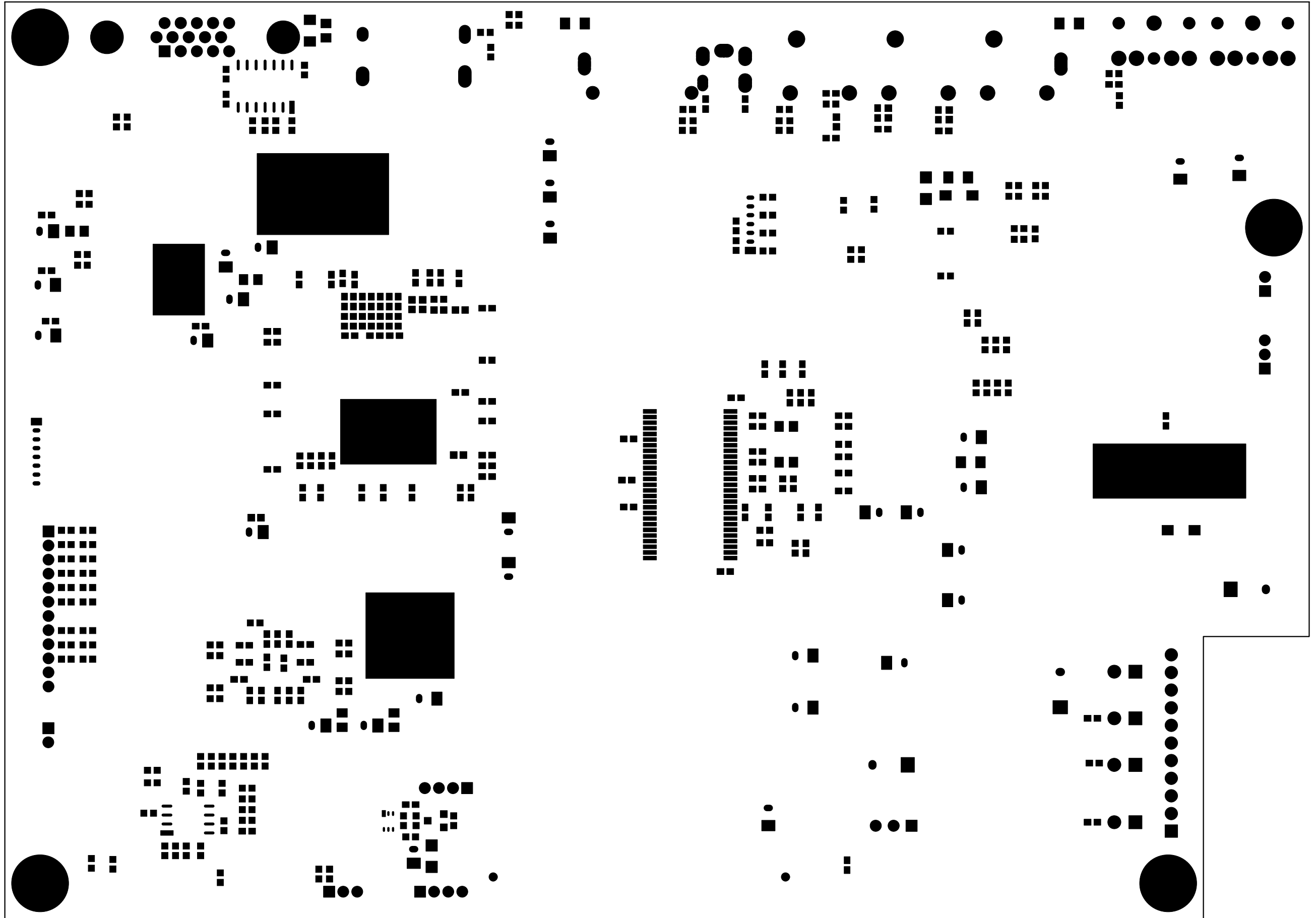

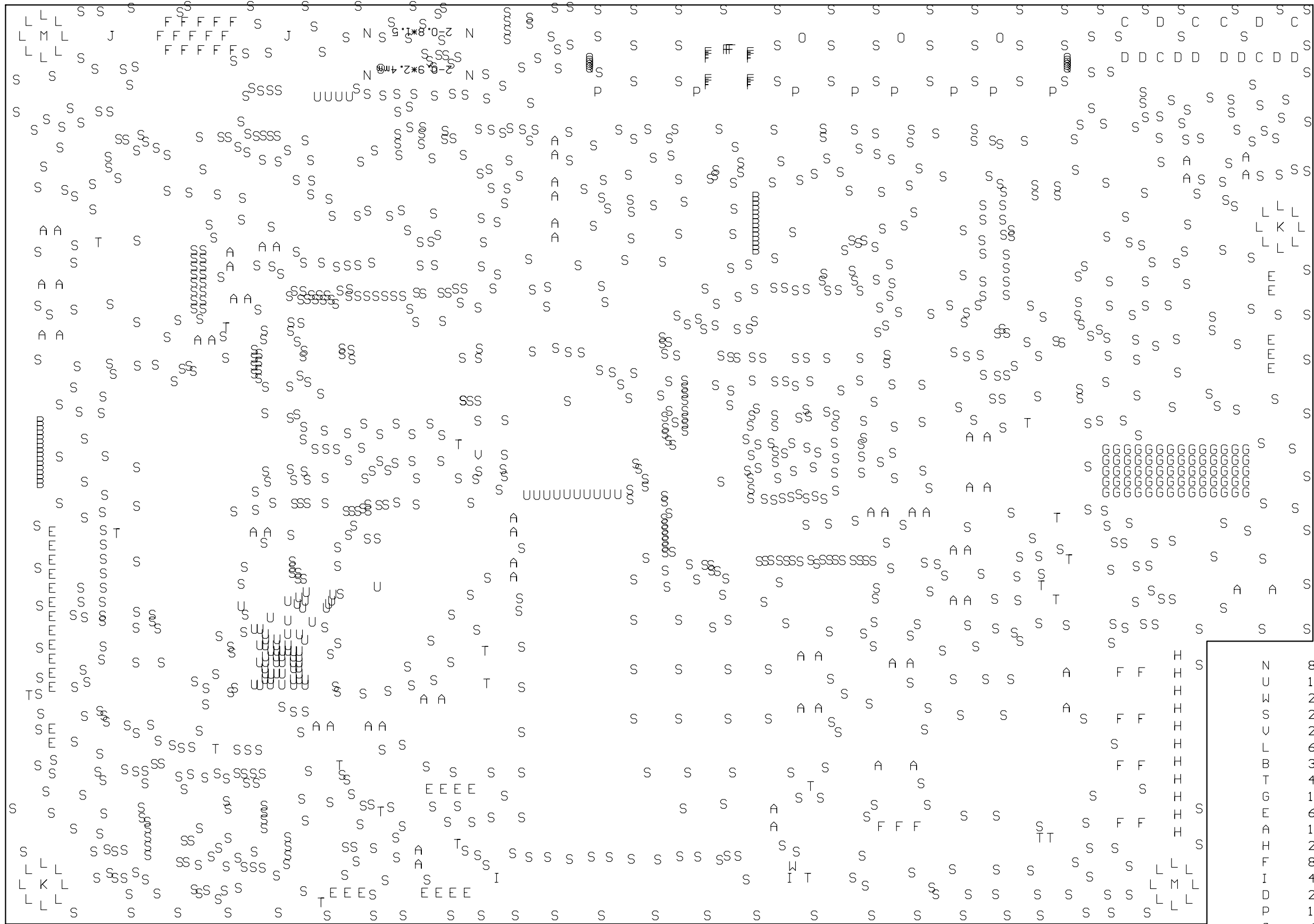

N	8	1mil	0.0254mm	PTH
U	154	10mil	0.254mm	PTH
W	2	12mil	0.3048mm	PTH
S	2464	14mil	0.3556mm	PTH
V	2	18mil	0.4572mm	PTH
L	64	19.685mil	0.5mm	PTH
B	30	23.622mil	0.6mm	PTH
T	42	24mil	0.6096mm	PTH
G	140	30mil	0.762mm	PTH
E	60	33.465mil	0.85001mm	PTH
A	128	35.433mil	0.9mm	PTH
H	22	37.402mil	0.95001mm	PTH
F	84	40mil	1.016mm	PTH
I	4	44mil	1.1176mm	NPTH
D	20	47.244mil	1.2mm	PTH
P	16	52mil	1.3208mm	PTH
O	6	60mil	1.524mm	PTH
C	12	62.992mil	1.6mm	NPTH
Q	20	67mil	1.7018mm	NPTH
R	6	118.11mil	2.99999mm	PTH
J	4	126mil	3.2004mm	PTH
M	4	137.795mil	3.49999mm	PTH
K	4	177.165mil	4.49999mm	PTH
	3296	Total		



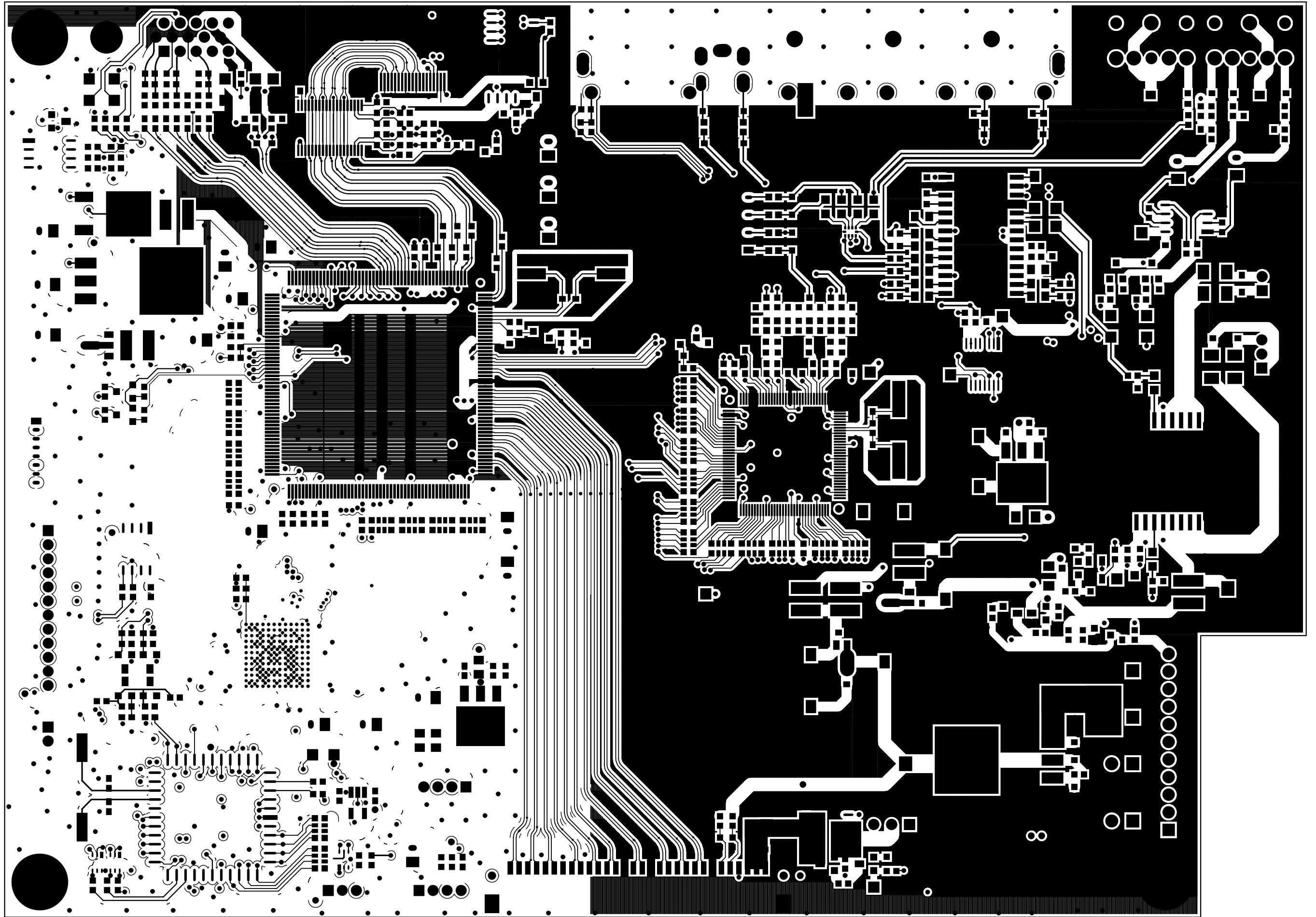

10. Exploded Diagram and Exploded Parts List

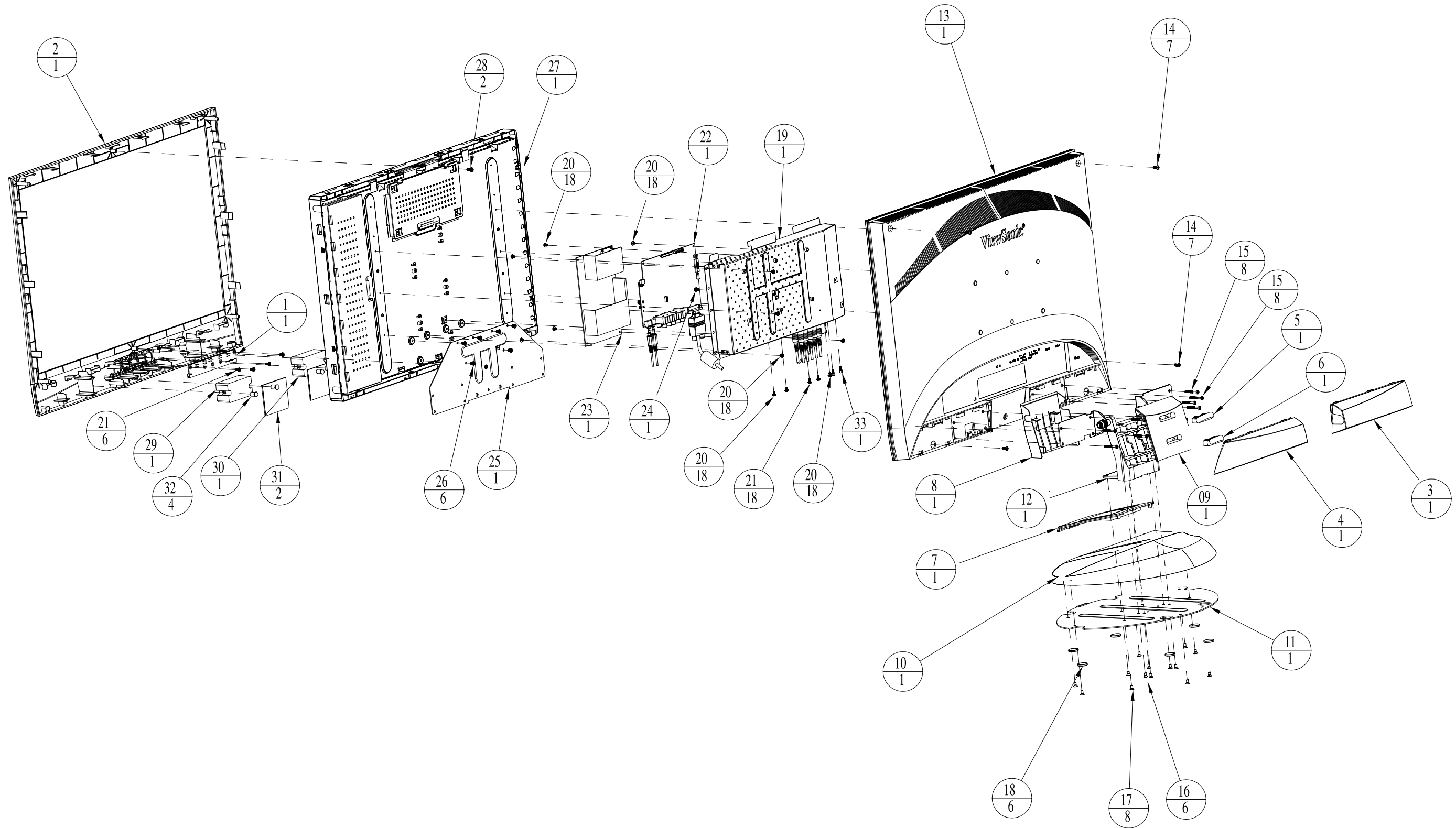

EXPLODED PARTS LIST (VX2835wm-1)

ViewSonic Model Number: VS11531

Rev: 1a

Serial No. Prefix: QFG

Item	ViewSonic P/N	Ref. P/N	Description	Q'ty
1	B-00008444	70-V9350200G040	VX1935 KEY BOARD ASS'Y (LF)(Premier)	1
2	C-00008464	45-X2830100G000	VX2835 BEZEL SUB ASSY	1
	N/A	40-04020019G000	VX2835 LED LENS	1
	M-00008126	42-04170013G000	VX2835 Viewsonic logo for viewsonic,AL	1
	M-00008125	42-04170012G000	VX2835 bird logo for viewsonic,AL	1
	N/A	40-03010051G000	VX2835-BUTTON,ABS,BLACK	1
	N/A	40-03010050G000	VX2835-BUTTON1,ABS,BLACK	1
	N/A	40-01010097G000	VX2835-BEZEL,ABS-HB,BLACK	1
3	C-00008469	40-07010011G000	VX2835 HINGE COVER R,ABS HB,BLACK	1
4	C-00008468	40-07010010G000	VX2835 HINGE COVER L,ABS HB,BLACK	1
5	N/A	40-09010005G000	VX2835 cable clipper up,ABS-HB,pan 877c	1
6	N/A	40-09010006G000	VX2835 cable clipper down,ABS-HB,pan 877	1
7	C-00008470	40-11010002G000	VX2835 BASE COVER,ABS-HB,pan 877c	1
8	M-00008124	40-05010032G000	VX2835 ARM FRONT	1
9	C-00008467	40-05010033G000	VX2835 ARM COVER,ABS-HB,pan 877c	1
10	C-00008466	40-06010031G000	VX2835 BASE,ABS-HB,BLACK	1
11	N/A	41-03010073G000	VX2835 BASE BKT,SECC,t=2.0mm	1
12	N/A	41-07010027G000	VX2835 HINGE,SECC+AL	1
13	C-00008465	40-02010042G000	VX2835-BACK COVER,ABS-HB,BLACK	1
14	N/A	43-01041203-010	SCREW M4*12 W*6.8 T/2.5MM PAN BK TAP	7
15	N/A	43-01043001G040	SCREW,M4*30,PAN,PT,ZN	8
16	N/A	43-04040804G000	SCREW M4*8 FLAT BZ ME	6
17	N/A	43-04040804G010	SCREW M4*8 FLAT BZ TAP	8
18	PL-00008001	42-02110002G000	HU171 Rubber Foot Black	6
19	N/A	41-04010030G000	VX2835 shielding,secc,t=0.8mm	1
20	N/A	43-12030502G000	SCREW M3*5 ROUND WASHER NI ME	18
21	N/A	43-12030801G010	SCREW M3x8 Round washer Zn Tap	6
22	N/A	70-Y2832500G000	VX2835 H/W PCB SUB ASSY	1
23	B-00008445	71-Y2831200G001	POWER MODULE 217W (PHIHONG)	1
24	N/A	43-01040605G400	SCREW M4*6,PAN,STAR Washer,CZ ,ME	1
25	N/A	41-03010072G000	VX2835 HINGE BKT,SECC,t=1.6mm	1
26	N/A	43-10040602G000	SCREW,M4x6L,CH,NI,ME	6
27	E-00008481	280MUW1-A00	LIQUID CRYSTAL DEVICE HSD280MUW1-A	1
28	N/A	43-12041002G010	SCREW M4*10 ROUND WASHER NI TAP	2
29	E-00008483	30-20033001G000	VX2835 SPEAKER 3.0W/8L LEFT	1
30	E-00008482	30-20033000G000	VX2835 SPEAKER 3.0W/8R Right	1
31	N/A	42-02110036G000	VX2835 SPEAKER RUBBER SPONGER	2
32	N/A	42-02110028G000	VX2835_SPEAKER_RUBBER	4
33	N/A	43-90000082G000	SCREW 4#-40*5*6.8 NI	2

11. Recommended Spare Parts List

RECOMMENDED SPARE PARTS LIST (VX2835wm-1)

ViewSonic Model Number: VS11531

Serial No. Prefix: QFG

Rev: 1a

Item	Description	ECR/ECN	ViewSonic P/N	Ref. P/N	Location	Universal number#
1	Accessories:					
2	[Adapter, Remote Control]		A-00008004	33-		
3			A-00008038	33-		
4			A-00008039	33-		
5			A-00008040	33-		
6	PC Board		B-00008444	70-V9350200G040		
7	Assembly: [All]		B-00008445	71-Y2831200G001		
8	Cabinets:		C-00008464	45-X2830100G000		
9	[Flyback, Back Cover, Base]		C-00008465	40-02010042G000		
10			C-00008466	40-06010031G000		
11			C-00008467	40-05010033G000		
12			C-00008468	40-07010010G000		
13			C-00008469	40-07010011G000		
14			C-00008470	40-11010002G000		
15	Cables: [All Cables]		CB-00008001	33-00090501G000		
16	Documentation:		DC-00008001	62-07000009G000		
17	[Quick Start Guide, CD Rom]		DC-00008002	62-07000010G000		
18			DC-00008003	62-07000011G000		
19			DC-00008429	72-28350100G110		
20			DC-00008430	72-28350100G210		
21			DC-00008431	72-28350100G310		
22			DC-00008432	42-01120015G000		
23	Electronic Components:		E-00008481	280MUW1-A00		
24	ICRT-EEPROM.		E-00008482	30-20033000G000		
25			E-00008483	30-20033001G000		
26	Miscellaneous:		M-00008124	40-05010032G000		
27			M-00008125	42-04170012G000		
28			M-00008126	42-04170013G000		
29	Packing Material:		P-00008481	60-01000117G610		
30	[Box, Foam]		P-00008482	61-01000058G000		
31			P-00008483	61-01000059G000		
32			P-00008484	61-01000064G000		
33			P-00008485	61-01000065G000		
34			P-00008486	61-03000017G000		
35			P-00008487	61-03000018G000		

Remark 1: Above listed items are examples, supplier can expand the rows to add more necessary items.

Remark 2: All revised RSPLs with newly added items or any change made should be highlighted and correlated with the ECN/ECR approved by ViewSonic Corporation. This is to eliminate repeated cross checks of each item between this version and prior versions.

BOM LIST (VX2835wm-1)

ViewSonic Model Number: VS11531

Rev: 1a

Serial No. Prefix: QFG

Item	ViewSonic P/N	Ref. P/N	Description	Location	Universal number#	Q'ty
1	N/A	04-1Y283A00G000	EDID VX2835 280MUW1A00 EDID A R10.0			1
2	N/A	04-1Y283A00G100	EDID VX2835 280MUW1A00 EDID DA R10.0			1
3	N/A	06-Y2830000G000	Bin Code VX2835 DL-FLA-280MUW1A00R30.0			1
4	N/A	06-Y2831200G000	Bin Code VX2835 DL H00-280MUW1A00R30.0			1
5	N/A	06-Y2831200G010	Bin Code VX2835 DL H01-280MUW1A00R30.0			1
6	N/A	20-9MB04139G040	LED BLUE/Orange3P DIP (ENGYA)			1
7	E-00008481	280MUW1-A00	LIQUID CRYSTAL DEVICE HSD280MUW1-A			1
8	E-00008482	30-20033000G000	VX2835 SPEAKER 3.0W/8R Right			1
9	E-00008483	30-20033001G000	VX2835 SPEAKER 3.0W/8L LEFT			1
10	N/A	31-10400100G000	SW TACT 160GF DIP TSAC-2L			5
11	N/A	32-31002083G000	CONN W TO B 2P P*2.0 C1U2X-XX0VX(TACT)			2
12	N/A	32-31012085G000	CONN W TO B 12P P*2.0 C1U2X-XX0VX(TACT)			1
13	N/A	33-00080000G000	PWR CORD AMERICAN(UL/CSA) 125V/10A 1800m			1
14	A-00008039	33-E3980000G000	PWR CORD US 125V/10A 1.8M 3C BLK Linetek			1
15	N/A	33-00000004G000	PWR CORD EUR 250V/10A 1800MM 3C BLK			1
16	A-00008040	33-E3980003G000	PWR CORD EU 250V/10A 1.8M 3C BLK Linetek			1
17	A-00008003	33-00080002G000	PWR CORD CHINA 250V/10A 1800MM LF			1
18	A-00008038	33-E3980005G000	PWR CORD CN 250V/10A 1.8M 3C BLK Linetek			1
19	N/A	33-E3910011G000	PWR CORD TAIWAN (BSMI) 125V/7A1800mm blk			1
20	A-00008004	33-E3980011G000	PWR CORD TW 125V/7A 1.8M 3C BLK Linetek			1
21	CB-00008001	33-00090501G000	CABLE SIGNAL D/15P-15P(M)1800MM			1
22	CB-00008097	33-R3910501G000	CABLE SIGNAL D/15P-15P(M)1800MM-JHEN VEI			1
23	CB-00008003	33-00070500G000	CABLE STEREO PHONE SZE33261B			1
24	CB-00008109	33-R3910506G000	CABLE STEREO PHONE(JHEN VEI)			1
25	N/A	33-Y2830201G000	AC INLET WIRE HRN 3PTO3P100MM(SZE71030B)			1
26	N/A	33-Y2830201G400	WIRE HRN 11P/2.5mm 24AWG 170mm			1
27	N/A	33-Y2830201G401	Wire HRN HRS DF14 to 30p/1.2532AWG 170mm			1
28	N/A	33-Y2830201G500	WIRE HRN 12P/2.0mm 28AWG 360mm			1
29	N/A	33-Y2830201G600	WIRE HRN 10P/2.5mm 24AWG 300mm			1
30	N/A	33-Y2830201G700	WIRE HRN 3P-3P Speaker-R 370MM(大朋)			1
31	N/A	33-Y2830201G701	WIRE HRN 2P-2P Speaker-L 370MM(大朋)			1
32	N/A	33-Y2830501G010	Cable SIGNAL CVBS/R/L 1800mm(GLET)			1
33	N/A	33-Y2830601G200	Cable HDMI To DVI 1.8M(GLET)			1
34	N/A	34-01230020G000	Gasket W10*L10*H18			1
35	N/A	34-04170003G000	V261 Conductive Al Foil L50*W42			1
36	N/A	34-04170009G000	Al foil,W*L*H=30*50*0.1mmr			2
37	N/A	34-04170025G000	AL FOIL W50*L150*t0.1mm			1
38	N/A	34-04170026G000	AL foil W50*L370*t0.1			1
39	N/A	39-VX193500G000	VX1935 Key Board PCB Ver : 2.0			1
40	N/A	40-01010097G000	VX2835-BEZEL,ABS-HB,BLACK			1
41	C-00008465	40-02010042G000	VX2835-BACK COVER,ABS-HB,BLACK			1
42	N/A	40-03010050G000	VX2835-BUTTON1,ABS,BLACK			1
43	N/A	40-03010051G000	VX2835-BUTTON,ABS,BLACK			1
44	N/A	40-04020019G000	VX2835 LED LENS			1
45	M-00008124	40-05010032G000	VX2835 ARM FRONT,ABS-HB,pan 877c			1
46	C-00008467	40-05010033G000	VX2835 ARM COVER,ABS-HB,pan 877c			1
47	C-00008466	40-06010031G000	VX2835 BASE,ABS-HB,BLACK			1
48	C-00008468	40-07010010G000	VX2835 HINGE COVER L,ABS HB,BLACK			1
49	C-00008469	40-07010011G000	VX2835 HINGE COVER R,ABS HB,BLACK			1
50	N/A	40-09010005G000	VX2835 cable clipper up,ABS-HB,pan 877c			1
51	N/A	40-09010006G000	VX2835 cable clipper down,ABS-HB,pan 877			1
52	C-00008470	40-11010002G000	VX2835 BASE COVER,ABS-HB,pan 877c			1
53	N/A	41-03010072G000	VX2835 HINGE BKT,SECC,t=1.6mm			1
54	N/A	41-03010073G000	VX2835 BASE BKT,SECC,t=2.0mm			1
55	N/A	41-04010030G000	VX2835 shielding,secc,t=0.8mm			1
56	N/A	41-07010027G000	VX2835 HINGE,SECC+AL			1
57	DC-00008432	42-01120015G000	mylar 394*617*0.1mm for VIEWSONIC 2835			1
58	PL-00008001	42-02110002G000	HU171 Rubber Foot Black			6
59	C-00008005	42-02110008G000	Back cover of ESD rubber-2 Black φ7*1.5			6
60	N/A	42-02110028G000	VX2835 SPEAKER RUBBER			4
61	N/A	42-02110036G000	VX2835 SPEAKER RUBBER SPONGER			2
62	M-00008125	42-04170012G000	VX2835 bird logo for viewsonic,AL			1
63	M-00008126	42-04170013G000	VX2835 Viewsonic logo for viewsonic,AL			1
64	N/A	42-10230001G000	Elec. tape cloth black W:15mm,TL:30mr			0.008
65	N/A	42-10230002G000	Elec.Tape cloth black W:40mm,TL=30mr			0.045
66	N/A	43-01040605G400	SCREW M4*6,PAN,STAR Washer,CZ ,ME			1
67	N/A	43-01041203-010	SCREW M4*12 W*6.8 T/2.5MM PAN BK TAP			7

Item	ViewSonic P/N	Ref. P/N	Description	Location	Universal number#	Q'ty
68	N/A	43-01043001G040	SCREW,M4*30,PAN,PT,ZN			8
69	N/A	43-04040804G000	SCREW M4*8 FLAT BZ ME			6
70	N/A	43-04040804G010	SCREW M4*8 FLAT BZ TAP			8
71	N/A	43-10040602G000	SCREW,M4x6L,CH,NI,ME			6
72	N/A	43-12030502G000	SCREW M3*5 ROUND WASHER NI ME			18
73	N/A	43-12030801G010	SCREW M3x8 Round washer Zn Tap			6
74	N/A	43-12041002G010	SCREW M4*10 ROUND WASHER NI TAP			2
75	N/A	43-90000082G000	SCREW 4#-40*5*6.8 NI			2
76	C-00008464	45-X2830100G000	VX2835 BEZEL SUB ASSY			1
77	P-00008481	60-01000117G610	VX2835wm Carton,Taiwan			1
78	P-00008482	61-01000058G000	VX2835 END CAP-R-top EPS			1
79	P-00008483	61-01000059G000	VX2835 END CAP-L-top EPS			1
80	P-00008484	61-01000064G000	VX2835 END CAP-R-bottom EPS			1
81	P-00008485	61-01000065G000	VX2835 END CAP-L-bottom EPS			1
82	P-00008486	61-03000017G000	PE Bag,800*1000mm*0.05t			1
83	P-00008487	61-03000018G000	VX2835 PE bag,1170mm*1095mm*0.08t			1
84	N/A	62-02000044G000	VSC vista insert flyer(Art paper)			1
85	N/A	62-03000018G000	ViewSonic Warranty China			1
86	N/A	62-05000075G010	VX2835wm ID Label,Taiwan			1
87	N/A	62-06000003G000	BARCODE LABEL 76.2*76.2MM			1
88	N/A	62-06000004G000	BARCODE LABEL 50*25MM			1
89	N/A	62-06000005G000	BARCODE LABEL 25*12MM			1
90	N/A	62-06000006G000	Barcode label 35*4mm			1
91	DC-00008001	62-07000009G000	Energy Star Label			1
92	DC-00008002	62-07000010G000	QC-Pass Label			1
93	DC-00008003	62-07000011G000	Hi-Pot Pass Label			1
94	N/A	62-07000014G000	Customer label			1
95	N/A	62-07000015G000	ViewSonic Customer label 180*100mm			1
96	N/A	62-07000027G000	VSC manufacture sticker			1
97	B-00008444	70-V9350200G040	VX1935 KEY BOARD ASS'Y (LF)(Premier)			1
98	B-00008074	70-VX193500G000	VX1935 KEY BOARD ASS'Y (Lead Free)			1
99	N/A	70-Y2832500G000	VX2835 H/W PCB SUB ASSY			1
100	B-00008445	71-Y2831200G001	POWER MODULE 217W (PHIHONG)			1
101	DC-00008429	72-28350100G110	VX2835 TWN packing assy,made in Taiwan			1
102	N/A	72-28350100G210	VX2835 China packing assy,made in Taiwan			1
103	DC-00008431	72-28350100G310	VX2835wm USA Packing assy,made in Taiwan			1

* *Reader's Response* *

Dear Readers:

Thank you in advance for your feedback on our Service Manual, which allows continuous improvement of our products. We would appreciate your completion of the Assessment Matrix below, for return to ViewSonic Corporation.

Assessment

A. What do you think about the content of this Service Manual?

<i>Unit</i>	<i>Excellent</i>	<i>Good</i>	<i>Fair</i>	<i>Bad</i>
1. Precautions and Safety Notices				
2. Specification				
3. Front Panel Function Control Description				
4. Circuit Description				
5. Adjustment Procedure				
6. Troubleshooting Flow Chart				
7. Block Diagrams				
8. Schematic Diagrams				
9. PCB Layout Diagrams				
10. Exploded Diagram and Exploded Parts List				
11. Recommended Spare Parts List				

B. Are you satisfied with this Service Manual?

<i>Item</i>	<i>Excellent</i>	<i>Good</i>	<i>Fair</i>	<i>Bad</i>
1. Service Manual Content				
2. Service Manual Layout				
3. The form and listing				

C. Do you have any other opinions or suggestions regarding this service manual?

Reader's basic data:

Name:		Title:	
Company:			
Add:			
Tel:		Fax:	
E-mail:			

After completing this form, please return it to ViewSonic Quality Assurance in the USA at facsimile 1-909-839-7943. You may also e-mail any suggestions to the Director, Quality Systems & Processes (marc.maupin@viewsonic.com)