

Service Manual

ViewSonic VX924

Model No. VS10162

19" Color TFT LCD Display

(VX912_SM. 1a May 2005)

ViewSonic® 381 Brea Canyon Road, Walnut, California 91789 USA - (800) 888-8583

Copyright

Copyright © 2005 by ViewSonic Corporation. All rights reserved. No part of this publication may be reproduced, transmitted, transcribed, stored in a retrieval system, or translated into any language or computer language, in any form or by any means, electronic, mechanical, magnetic, optical, chemical, manual or otherwise, without the prior written permission of ViewSonic Corporation.

Disclaimer

ViewSonic makes no representations or warranties, either expressed or implied, with respect to the contents hereof and specifically disclaims any warranty of merchantability or fitness for any particular purpose. Further, ViewSonic reserves the right to revise this publication and to make changes from time to time in the contents hereof without obligation of ViewSonic to notify any person of such revision or changes.

Trademarks

Optiquest is a registered trademark of ViewSonic Corporation.
ViewSonic is a registered trademark of ViewSonic Corporation.
All other trademarks used within this document are the property of their respective owners.

Revision History

Revision	SM Editing Date	ECR Number	Description of Changes	Editor
1a	05/09/05		Initial Release	A. Lu

TABLE OF CONTENTS

1. Precautions and Safety Notices	1
2. Specification	5
3. Front Panel Function Control Description	11
4. Circuit Description	17
5. Adjustment Procedure	27
6. Troubleshooting Flow Chart	49
7. Recommended Spare Parts List	55
8. Exploded Diagram and Spare Parts List	58
9. Block Diagram	68
10. Schematic Diagrams	70
11. PCB Layout Diagrams	78

1. Precautions and Safety Notices

1. Appropriate Operation

- (1) Turn off the product before cleaning.
- (2) Use only a dry soft cloth when cleaning the LCD panel surface.
- (3) Use a soft cloth soaked with mild detergent to clean the display housing.
- (4) Use only a high quality, safety approved AC/DC power cord.
- (5) Disconnect the power plug from the AC outlet if the product will not be used for a long period of time.
- (6) If smoke, abnormal noise, or strange odor is present, immediately switch the LCD display off.
- (7) Do not touch the LCD panel surface with sharp or hard objects.
- (8) Do not place heavy objects on the LCD display, video cable, or power cord.
- (9) Do not use abrasive cleaners, waxes or solvents for your cleaning.
- (10) Do not operate the product under the following conditions:
 - Extremely hot, cold or humid environment.
 - Areas containing excessive dust and dirt.
 - Near any appliance generating a strong magnetic field.
 - In direct sunlight.

2. Caution

No modification of any circuit should be attempted. Service work should only be performed after you are thoroughly familiar with all of the following safety checks and servicing guidelines.

3. Safety Check







Care should be taken while servicing this LCD display. Because of the high voltage used in the inverter circuit, the voltage is exposed in such areas as the associated transformer circuits.

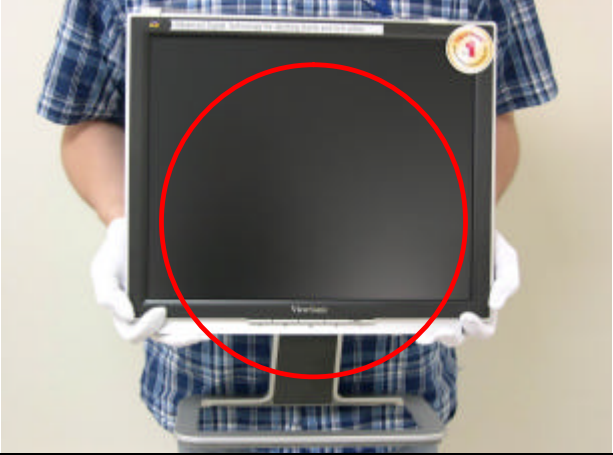

4. LCD Module Handling Precautions

4.1 Handling Precautions

- (1) Since front polarizer is easily damaged, pay attention not to scratch it.
- (2) Be sure to turn off power supply when connecting or disconnecting input connector.
- (3) Wipe off water drops immediately. Long contact with water may cause discoloration or spots.
- (4) When the panel surface is soiled, wipe it with absorbent cotton or other soft cloth.
- (5) Since the panel is made of glass, it may break or crack if dropped or bumped on hard surface.
- (6) Since CMOS LSI is used in this module, take care of static electricity and ensure human earth when handling.
- (7) Do not open or modify the Module Assembly.
- (8) Do not press the reflector sheet at the back of the module in any direction.
- (9) In the event that a Module must be put back into the packing container slot after it was taken out of the container, do not press the center of the CCFL Reflector edge. Instead, press at the far ends of the CFL Reflector edge softly. Otherwise the TFT Module may be damaged.
- (10) At the insertion or removal of the Signal Interface Connector, be sure not to rotate or tilt the Interface Connector of the TFT Module.

- (11) After installation of the TFT Module into an enclosure (LCD monitor housing, for example), do not twist or bend the TFT Module even momentarily. When designing the enclosure, it should be taken into consideration that no bending/twisting forces may be applied to the TFT Module from outside. Otherwise the TFT Module may be damaged.
- (12) The cold cathode fluorescent lamp in the LCD contains a small amount of mercury. Please follow local ordinances or regulations for disposal.
- (13) The LCD module contains a small amount of materials having no flammability grade. The LCD module should be supplied with power that complies with the requirements of Limited Power Source (IEC60950 or UL1950), or an exemption should be applied for.
- (14) The LCD module is designed so that the CCFL in it is supplied by a Limited Current Circuit (IEC60950 or UL1950). Do not connect the CCFL to a Hazardous Voltage Circuit.

Correct methods :	Incorrect Methods :
<p>Only touch the metal frame of the panel or the front cover of the monitor. Do not touch the surface of the polarizer .</p>	<p>If the surface of the panel is pressed by fingers, this may cause "MURA."</p>
	
	
<p>Take out the monitor by grasping the cushion.</p>	<p>If the monitor is removed by grasping the LCD panel, that may cause "MURA."</p>
	

Correct Methods :	Incorrect Methods :
Place the monitor on a clean & soft foam pad .	If the monitor is placed on foreign objects, that could scratch the surface of the panel.
	

2. Specification

• GENERAL specification

Test Resolution & Frequency	1280x1024 @ 60Hz
Test Image Size	Full Size
Contrast and Brightness Controls	Factory Default: Contrast = 70%, Brightness = 100%

• VIDEO INTERFACE

Analog Input Connector	DB-15 (Analog), refer the appendix A
Digital Input Connector	DVI-I (Digital), refer the appendix B
Default Input Connector	Defaults to the first detected input
Video Cable Strain Relief	Equal to twice the weight of the monitor for five minutes
Video Cable Connector DB-15 Pin out	Compliant DDC 1/2B
Video Signals	1. Video RGB (Analog) Separate, Composite, and Sync on Green 2. TMDS (Digital)
Video Impedance	75 Ohms (Analog), 100 Ohms (Digital)
Maximum PC Video Signal	950 mV with no damage to monitor
Maximum Mac Video Signal	1250 mV with no damage to monitor
Sync Signals	LVDS
DDC 1/2B	Compliant with Revision 1.3
Sync Compatibility	Separate Sync, Composite Sync, SOG
Video Compatibility	Shall be compatible with all PC type computers, Macintosh computers, and after market video cards
Resolution Compatibility	640 x 350*, 640 x 480, 720 x 400* (640 x 400*), 800 x 600, 832 x 624, 1024 x 768, 1152 x 864, 1152 x 870, 1280 x 720, 1280 x 960, 1280 x 1024 * The image vertical size might not be full screen. But the image vertical position should be at the center.
Exclusions	Not compatible with interlaced video

● **POWER SUPPLY**

Internal Power Supply	Part Number: FSP035-1PI01
Input Voltage Range	90 TO 264 VAC
Input Frequency Range	47.5 TO 63 HERTZ
Short Circuit Protection	Output can be shorted without damage
Over Current Protection	3.5 A typical at 12.0 VDC (Protect when short circuit)
Leakage Current	0.75mA (Max) at 264VAC / 50Hz
EFFICIENCY	77 % typical at 115VAC Full Load
Fuse	Internal and not user replaceable
Power Dissipation	35 Watts (typ)
Max Input AC Current	1.2 Arms @ 90VAC, 0.7 Arms @265VAC
INRUSH CURRENT (COLD START)	60 A @ 115VAC
Power Supply Cold Start	Shall start and function properly when under full load, with all combinations of input voltage, input frequency, and operating temperature
Power Supply Transient Immunity	Shall be able to withstand an ANSI/IEEE C62.41-1980 2000V 200 ampere ring wave transient test with no damage
Power Supply Line Surge Immunity	Shall be able to withstand 1.5 times nominal line voltage for one cycle with no damage
Power Supply Missing Cycle Immunity	Shall be able to function properly, without reset or visible screen artifacts, when ½ cycle of AC power is randomly missing at nominal input
Power Supply Acoustics	The power supply shall not produce audible noise that would be detectable by the user. Audible shall defined to be in compliance with ISO 7779 (DIN EN27779:1991) Noise measurements of machines acoustics. Power Switch noise shall not be considered
US Type Power Cable	Separate 3-prong NEMA 5-15P type plug. Length = 1.8m. Connects to display. Color = Black
European Type Power Cable	Schuko CEE7-7 type plug. Length = 1.8m, Connects to display. Color = Black

CCC Type Power Cable	Separate 3-prong type plug. Length = 1.8m. Connects to display. Color = Black
PSE Type Power Cable	Separate 2-prong NEMA 1-15P type plug. Length = 1.8m. Connects to display. Color = Black
Power Saving Operation(Method)	VESA DPMS Signaling ON Mode < 40 W (Max) / 35 W (Typ)
Power Consumption	On Mode < 40 W (Max) / 35 W (Typ) Saving Mode < 2 W, Off Mode < 1 W
Recovery Time	On Mode = N/A, Active Off < 3 sec

● **ELECTRICAL REQUIREMENT**

Horizontal / Vertical Frequency

Horizontal Frequency	30 – 82 KHZ
Vertical Refresh Rate	50 – 75 HZ
Maximum Pixel Clock	135 MHz
Sync Polarity	Independent of sync polarity.

● **Timing Table**

Item	Timing	Analog	Digital
1	640 x 350 @ 70Hz, 31.5kHz	Yes	Yes
2	640 x 400 @ 60Hz, 31.5kHz	Yes	Yes
3	640 x 400 @ 70Hz, 31.5kHz	Yes	Yes
4	640 x 480 @ 50Hz, 24.7kHz	Yes	No
5	640 x 480 @ 60Hz, 31.5kHz	Yes	Yes
6	640 x 480 @ 67Hz, 35.0kHz	Yes	Yes
7	640 x 480 @ 72Hz, 37.9kHz	Yes	Yes
8	640 x 480 @ 75Hz, 37.5kHz	Yes	Yes
9	640 x 480 @ 85Hz, 43.27kHz	No	No
10	720 x 400 @ 70Hz, 31.5kHz	Yes	Yes
11	800 x 600 @ 56Hz, 35.1kHz	Yes	Yes
12	800 x 600 @ 60Hz, 37.9kHz	Yes	Yes
13	800 x 600 @ 75Hz, 46.9kHz	Yes	Yes
14	800 x 600 @ 72Hz, 48.1kHz	Yes	Yes
15	800 x 600 @ 85Hz, 53.7kHz	No	No
16	832 x 624 @ 75Hz, 49.7kHz	Yes	Yes

17	1024 x 768 @ 60Hz, 48.4kHz	Yes	Yes
18	1024 x 768 @ 70Hz, 56.5kHz	Yes	Yes
19	1024 x 768 @ 72Hz, 58.1kHz	Yes	Yes
20	1024 x 768 @ 75Hz, 60.0kHz	Yes	Yes
21	1024 x 768 @ 85Hz, 68.67kHz	No	No
22	1152 x 864 @ 75Hz, 67.5kHz	Yes	Yes
23	1152 x 870 @ 75Hz, 68.7kHz	Yes	Yes
24	1280 x 1024 @ 60Hz, 63.4kHz	Yes	Yes
25	1280 x 1024 @ 75Hz, 79.97kHz	Yes	Yes
26	1280x 720 @ 60Hz, 45kHz (HDTV)	Yes	Yes

- **Primary Presets**

1280x1024 @ 60Hz

- **User Presets**

Number of User Presets (recognized timings) Available: 10 presets total in FIFO configuration

- **Changing Modes**

- Maximum Mode Change Blank Time for image stability : 3 seconds (Max), excluding “Auto Adjust” time
- Under DOS mode (640 x 350, 720 x 400 & 640 x 400), it should recall factory setting when execute “Auto Adjust”
- The monitor needs to do “Auto Adjust” the first time when a new mode is detected
(See section “0-Touch™ Function Actions”)

● **TFT LCD PANEL**

1st Source Panel

Model number	AUO M190EN04 V5
Type	TN type with LVDS interface
Active Size	376.32 (H) x 301.06 (V)
Pixel Arrangement	RGB Vertical Stripe
Pixel Pitch	0.294 mm
GLASS TREATMENT	Anti Glare (Hard coating 3H)
# OF BACKLIGHTS	4 CCFL edge-light (2 top / 2 bottom)
BACKLIGHT LIFE	50,000 Hours (Min)
Luminance (5-point) – Condition: CT = 6500K, Contrast = Max, Brightness = Max	275 cd/m2 (Typ after 30 minute warm up) 215 cd/m2 (Min after 30 minute warm up)
Brightness Uniformity	≥ 70% Entire Area (min)
Contrast Ratio	550:1 (typ), 350:1 (min)
Color Depth	16.2 million colors (6 bits + 2 bits FRC)
Viewing Angle (Horizontal)	@ CR>10 Typical: 140° Minimum: 130°
Viewing Angle (Vertical)	@ CR>10 Typical: 135° Minimum: 125°
Response Time 10%-90% @ Ta=25°C	Total = 4.8ms (black – white) (Tr=3.4ms, Tf=1.4ms) Total = 4.0ms (gray – gray)
Panel Defects	Please see Panel Quality Specifications.

● **MECHANICAL**

Dimension (Desktop)

Width	431 mm (17 inch)
Height	468 mm (18.4 inch)
Depth	201 mm (7.9 inch)
Monitor Weight	6.7 Kg (14.8 lbs)

● **Dimension (Head Only / Wall Mount)**

Width	431 mm (17 inch)
Height	370 mm (14.6 inch)
Depth	66 mm (2.6 inch)
Monitor Weight	5.3 Kg (11.7 lbs)

● **Ergonomics**

Tilt Up	From 0° up to $\geq 20^\circ$
Tilt Down	From 0° down to $-3^\circ \sim -5^\circ$

● **ENVIRONMENTAL**

- Operating Temperature : 0°C to +40°C
- Storage Temperature : -20°C to +60°C
- Operating Relative Humidity : 20% to 90% RH Non-Condensing
- Storage Relative Humidity : 5% to 90% RH Non-Condensing
- Operating Altitude : 0 to +3,000 meters
- Storage Altitude : 0 to +12,000 meters

3. Front Panel Function Control Description

Adjusting the Screen Image

Use the buttons on the front control panel to display and adjust the OSD controls which display on the screen. The OSD controls are explained at the top of the next page and are defined in “Main Menu Controls” on page 13.

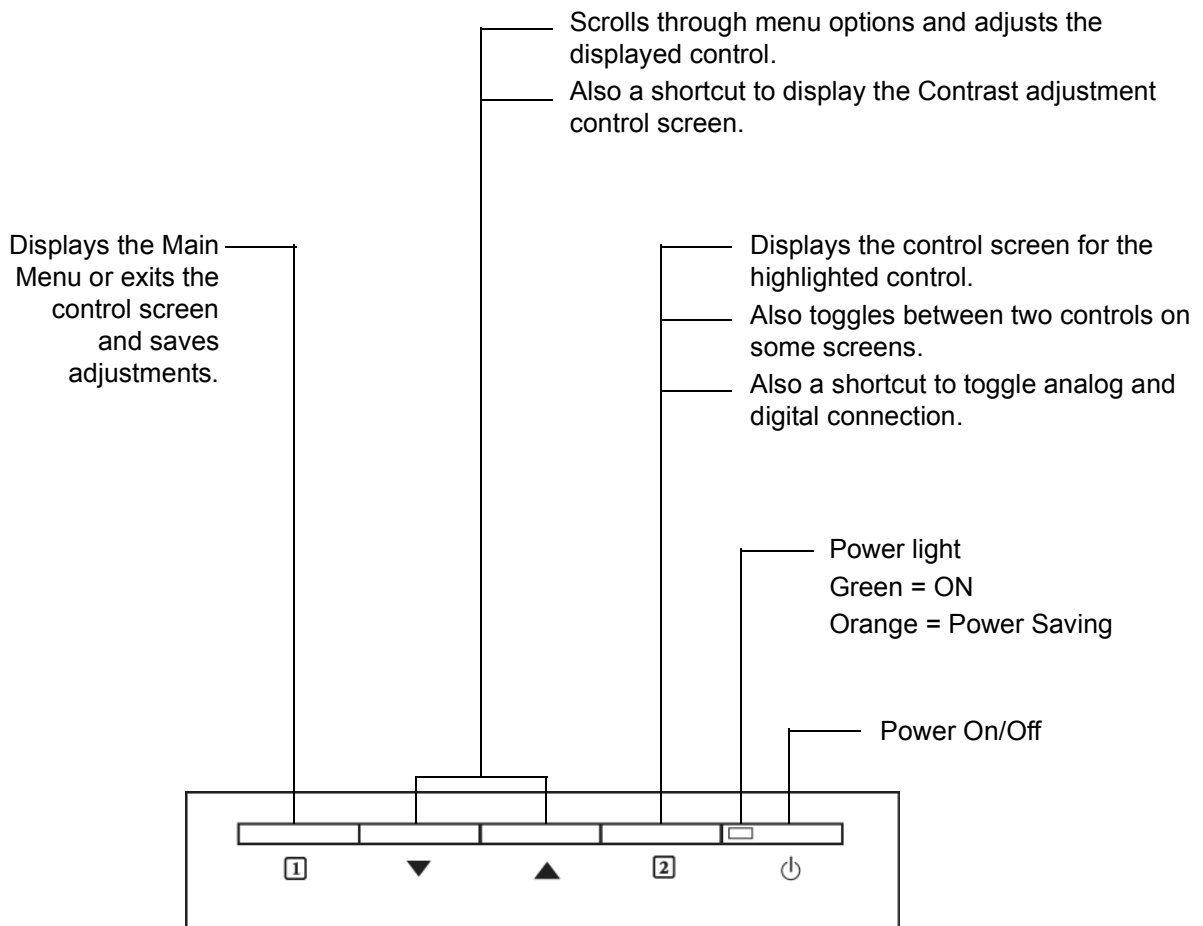
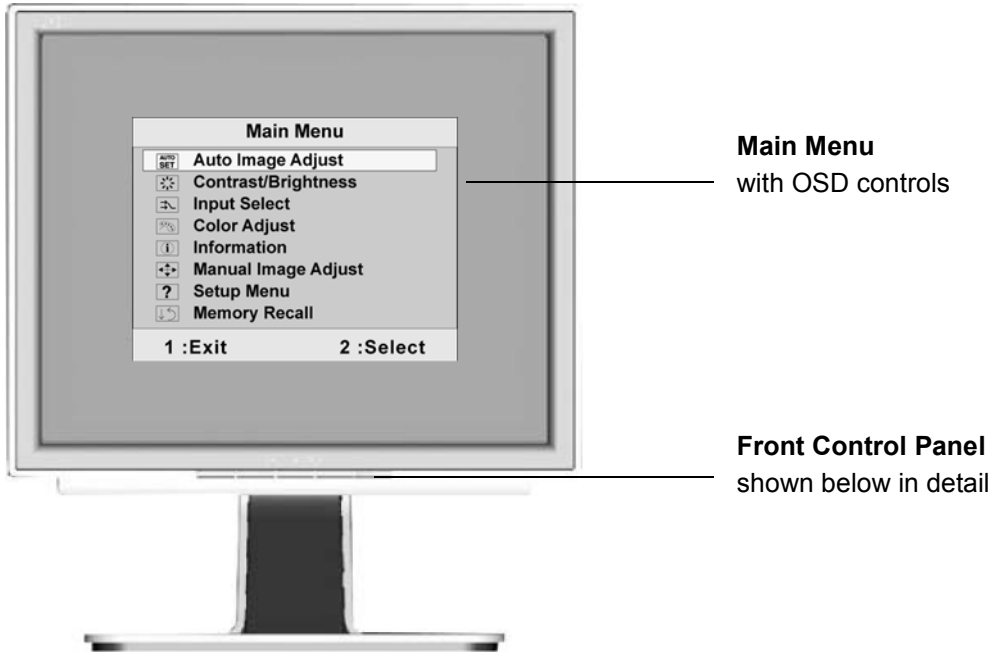

Do the following to adjust the display setting:

1. To display the Main Menu, press button [1].

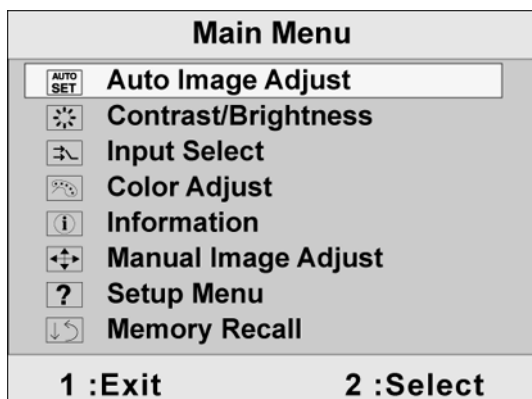

NOTE: All OSD menus and adjustment screens disappear automatically after about 30 seconds. This is adjustable through the OSD timeout setting in the setup menu.

2. To select a setting to be adjusted, press ▲ or ▼ to scroll up or down the Main Menu.
3. After the desired control is selected, press button [2]. A control screen like the one shown below appears.

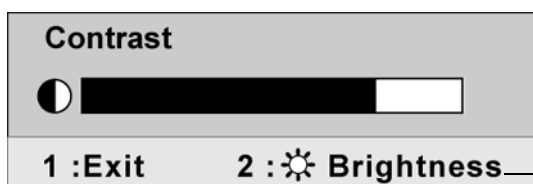

The line at the bottom of the screen tells you what you can do next: Exit or select the Brightness control.

4. To adjust the setting, press the up ▲ or down ▼ buttons.
5. To save the adjustments and exit the menu, press button [1] *twice*.

The following tips may help you optimize your display:

- Adjust your computer's graphics card so that it outputs a 1280 x 1024 @ 60Hz video signal to the LCD display. (Look for instructions on “changing the refresh rate” in your graphic card's user guide.)
- If necessary, make small adjustments using H. POSITION and V. POSITION until the screen image is completely visible. (The black border around the edge of the screen should barely touch the illuminated “active area” of the LCD display.)

Main Menu Controls

Adjust the menu items shown below by using the up▲and down▼buttons.

Control Explanation



Auto Image Adjust automatically sizes, centers, and fine tunes the video signal to eliminate waviness and distortion.

NOTE:

1. Auto Image Adjust works with most common video cards. If this function does not work on your LCD display, then lower the video refresh rate to 60 Hz and set the resolution to its pre-set value.
2. The Auto Image Adjust and most Manual Image Adjust functions are not available for DVI input.



Contrast adjusts the difference between the image background (black level) and the foreground (white level).



Brightness adjusts background black level of the screen image.



Input Select allows you to toggle between an analog and a digital signal.



Color Adjust provides several color adjustment modes: preset color temperatures and User Color which allows you to adjust red (R), green (G), and blue (B) separately. The factory setting for this product is 6500K (6500 Kelvin).

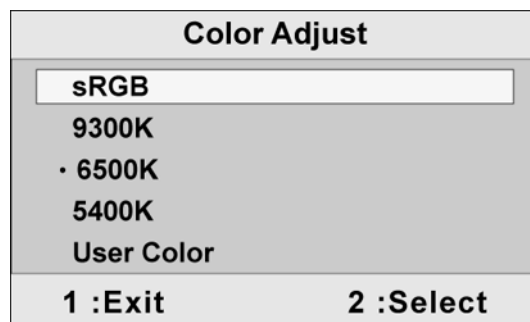

sRGB-sRGB is quickly becoming the industry standard for color management, with support being included in many of the latest applications. Enabling this setting allows the LCD display to more accurately display colors the way they were originally intended. Enabling the sRGB setting will cause the Contrast and Brightness adjustments to be disabled.

9300K-Adds blue to the screen image for cooler white (used in most office settings with fluorescent lighting).

Control Explanation

6500K-Adds red to the screen image for warmer white and richer red.

5400K-Adds green to the screen image for a darker color.

User Color Individual adjustments for red (R), green (G), and blue (B).

1. To select color (R, G or B) press button [2].

2. To adjust selected color, press▲or▼.

Important: If you select RECALL from the Main Menu when the product is set to a Preset Timing Mode, colors return to the 6500K factory preset.



Information displays the timing mode (video signal input) coming from the graphics card in your computer, the LCD model number, the serial number, and the ViewSonic® website URL. See your graphics card's user guide for instructions on changing the resolution and refresh rate (vertical frequency).

NOTE: VESA 1280 x 1024 @ 60Hz (recommended) means that the resolution is 1280 x 1024 and the refresh rate is 60 Hertz.

Information		
H. Frequency:	31.47	kHz
V. Frequency:	31.47	Hz
Pixel Clock:	24.80	MHz
Resolution:	640x480	
Model No:		
Serial No:		
www.ViewSonic.com		
1 :Exit	2 :Select	



Manual Image Adjust displays the Manual Image Adjust menu.

Manual Image Adjust	
	H. / V. Position
	H. Size
	Fine Tune
	Sharpness
1 :Exit	2 :Select

Control Explanation

The **Manual Image Adjust** controls are explained below:

H./V. Position (Horizontal/Vertical Position) moves the screen image left or right and up or down.

H. Size (Horizontal Size) adjusts the width of the screen image.

Fine Tune sharpens the focus by aligning the text and/or graphic characters.

Sharpness adjusts the clarity and focus of the screen image.



Setup menu displays the menu shown below:

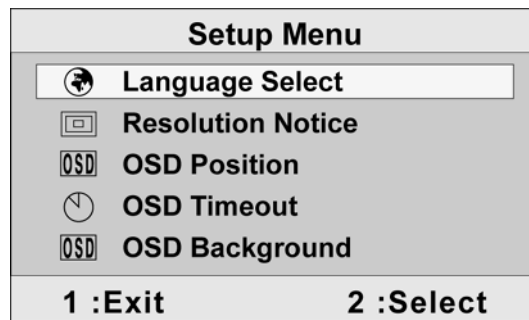

The **Setup Menu** controls are explained below:

Language allows you to choose the language used in the menus and control screens.

Resolution Notice displays the Resolution Notice menu shown below.

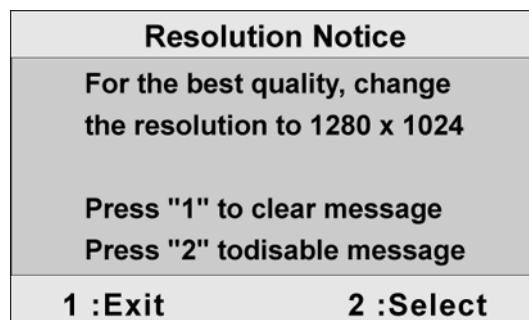

Resolution Notice advises the optimal resolution to use.

OSD Position allows you to move the on-screen display menus and control screens.

Control	Explanation
---------	-------------

OSD Timeout sets the length of time the on-screen display screen is displayed. For example, with a “15 second” setting, if a control is not pushed within 15 seconds, the display screen disappears.

OSD Background allows you to turn the On-Screen Display background On or Off.



Memory Recall returns the adjustments back to factory settings if the display is operating in a factory Preset Timing Mode listed in the Specifications of this manual.

Exception: This control does not affect changes made with the User Color control, Language or Power Lock setting.

4. Circuit Description

1. Outline

- 1.1 Buttons on the front panel: Power On/Off button, button 2 (ENTER / INPUT SELECT), up arrow button, down arrow button, button 1 (MENU).
- 1.2 The D-sub 15-pin connector, DVI-I connector and AC-IN jack are located on the back side of the cabinet.
- 1.3 The OSD menu includes the following functions:
 - Auto Image Adjust (only active under analog input)
 - Contrast/Brightness
 - Audio Adjust
 - Color Adjust
 - Information
 - Manual Image Adjust
 - Setup Menu
 - Memory Recall
- 1.4 Contrast and Brightness can be directly controlled with the UP / DOWN buttons.

2. Connectors

2.1 AC Socket: CEE22 type connector

2.2 Video signal connector for analog input: 15P Mini D-Sub

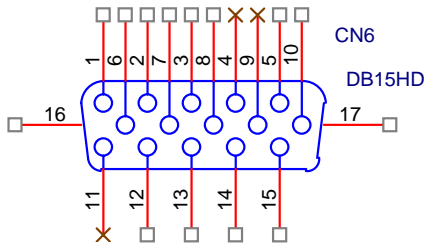

PIN	MNEMONIC	SIGNAL
1	RV	Red Video
2	GV	Green Video
3	BV	Blue Video
4	NC	None
5	GND	Ground(DDC return)
6	RG	Red GND
7	GG	Green GND
8	BG	Blue GND
9	+5V	+5V (for DDC)
10	SG	Sync GND
11	NC	None
12	SDA	DDC Data
13	HS	Horizontal Sync
14	VS	Vertical Sync
15	SCL	DDC Clock

2.3 Video signal connector for digital input: 24pin DVI-D connector

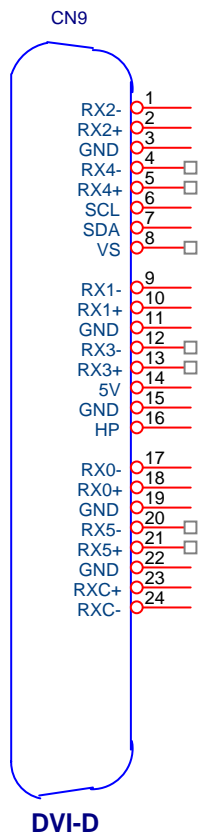

Pin No.	Signal Name	Description
1	RX2-	TMDS negative differential input, channel 2
2	RX2+	TMDS positive differential input, channel 2
3	GND	Logic Ground
4	RX4-	Reserved. No connection
5	RX4+	Reserved. No connection
6	SCL	DDC2B Clock
7	SDA	DDC2B Data
8	VS	Reserved. No connection
9	RX1-	TMDS negative differential input, channel 1
10	RX1+	TMDS positive differential input, channel 1
11	GND	Logic Ground
12	RX3-	Reserved. No connection
13	RX3+	Reserved. No connection
14	+5V	Power
15	GND	Logic Ground
16	HP	SENSE Pin, Pull High
17	RX0-	TMDS negative differential input, channel 0
18	RX0+	TMDS positive differential input, channel 0
19	GND	Logic Ground
20	RX5-	Reserved. No connection
21	RX5+	Reserved. No connection
22	GND	Logic Ground
23	RXC+	TMDS positive differential input, reference clock
24	RXC-	TMDS negative differential input, reference clock

3. Electrical Specifications

3.1 Standard conditions

Display Area	404.2 x 330.0 mm
Video Signal	0.7Vpp
Contrast	Max.
Brightness	Max.
Ambient	20 +/- 5 °C
Input	AC
Warming up	> 30 min
Display	1280 x 1024

3.2 Power

3.2.1 Power supply

Input voltage	100~240Vac
Power frequency	50~60Hz
Input current	<1.5A RMS @90V AC
Inrush current	<0.8A RMS @180V AC 50A(Max) at 120Vac(cold start)
Power consumption	35W(typical);40Watts(Max)

3.2.2 Power Management

State	Power	Indicator
On	35Watts	Green
Standby	< 1Watts	Amber
Off	<1Watts	Off

3.3 Acceptable timing

This LCD display can automatically detect and display input signals whose timing falls within the following limits.

Horizontal: Sync frequency: 30~82 kHz

Vertical: Sync frequency: 56~75Hz

3.4 Signal level and input impedance

3.4.1 Video signal level: 0.7Vp-p

3.4.2 Sync signal level - H/V separate: TTL level

3.4.3 Input impedance

Analog video input: 75 ohm

Digital video input: 100 ohm

Sync input: > 1 k ohm

Audio input: 10K ohm

4. Signal Cable: Signal cable with Mini D-Sub 15P connectors at both ends. Length: 1.8 meter.

5. EDID data

AUO Analog EDID

128 BYTES OF EDID CODE:

	0	1	2	3	4	5	6	7	8	9
0	00	FF	FF	FF	FF	FF	FF	00	5A	63
10	1C	0F	01	01	01	01	01	0F	01	03
20	0E	26	1E	78	2E	68	75	A2	5A	49
30	9F	23	13	50	54	BF	EF	80	81	80
40	71	4F	61	59	45	59	31	59	01	01
50	01	01	01	01	30	2A	00	98	51	00
60	2A	40	30	70	13	00	78	2D	11	00
70	00	1E	00	00	00	FF	00	50	53	33
80	30	35	30	31	30	30	30	30	31	0A
90	00	00	00	FD	00	32	55	1E	52	0E
100	00	0A	20	20	20	20	20	20	00	00
110	00	FC	00	56	58	39	32	34	0A	20
120	20	20	20	20	20	00	D3			

- (08-09) ID Manufacturer Name = VSC
- (11-10) Product ID Code = 0F1C
- (12-15) Last 5 Digits of Serial Number = Not Used
- (16) Week of Manufacture = 01
- (17) Year of Manufacture = 2005
- (10-17) Complete Serial Number = See Descriptor Block
- (18) EDID Version Number = 1
- (19) EDID Revision Number = 3
- (20) VIDEO INPUT DEFINITION:
 Analog Signal
 0.700, 0.300 (1.000 Vp-p)
 Separate Syncs, Composite Sync, Sync on Green
- (21) Maximum Horizontal Image Size = 380 mm
- (22) Maximum Vertical Image Size = 300 mm
- (23) Display Gamma = 2.20
- (24) Power Management and Supported Feature(s):
 Active Off/Very Low Power, Standard Default Color Space,
 Preferred Timing Mode
 Display Type = R/G/B Color
- (25-34) CHROMA INFO:
 Red X - 0.634 Green X - 0.287 Blue X - 0.138 White X - 0.313
 Red Y - 0.354 Green Y - 0.621 Blue Y - 0.077 White Y - 0.329
- (35) ESTABLISHED TIMING I:
 720 X 400 @ 70Hz (IBM,VGA)
 640 X 480 @ 60Hz (IBM,VGA)
 640 X 480 @ 67Hz (Apple,Mac II)
 640 X 480 @ 72Hz (VESA)
 640 X 480 @ 75Hz (VESA)
 800 X 600 @ 56Hz (VESA)
 800 X 600 @ 60Hz (VESA)

- (36) ESTABLISHED TIMING II:
 800 X 600 @ 72Hz (VESA)
 800 X 600 @ 75Hz (VESA)
 832 X 624 @ 75Hz (Apple,Mac II)
 1024 X 768 @ 60Hz (VESA)
 1024 X 768 @ 70Hz (VESA)
 1024 X 768 @ 75Hz (VESA)
 1280 X 1024 @ 75Hz (VESA)
- (37) Manufacturer's Reserved Timing:
 1152 X 870 @ 75Hz (Apple,Mac II)
- (38-53) Standard Timing Identification:
 1280 X 1024 @60Hz
 1152 X 864 @75Hz
 1024 X 768 @85Hz
 800 X 600 @85Hz
 640 X 480 @85Hz
 Not Used
 Not Used
 Not Used

(54-71) Detailed Timing / Descriptor Block 1:
 1280x1024 Pixel Clock: 108.00 MHz

	Horizontal Image Size: 376 mm	Vertical Image Size: 301 mm
	Refreshed Mode: Non-Interlaced	Normal Display - No Stereo
Horizontal:	Active Time: 1280 pixels	Blanking Time: 408 pixels
	Sync Offset: 48 pixels	Sync Pulse Width: 112 pixels
	Border: 0 pixels	Frequency: 63.98 KHz
Vertical:	Active Time: 1024 lines	Blanking Time: 42 lines
	Sync Offset: 1 lines	Sync Pulse Width: 3 lines
	Border: 0 lines	Frequency: 60.02 Hz

Digital Separate, Horizontal Polarity (+) Vertical Polarity (+)

(72-89) Detailed Timing / Descriptor Block 2:
 Monitor Serial Number:
 PS3050100001

(90-107) Detailed Timing / Descriptor Block 3:
 Monitor Range Limits:
 Min Vertical Freq - 50 Hz
 Max Vertical Freq - 85 Hz
 Min Horiz. Freq - 30 KHz
 Max Horiz. Freq - 82 KHz
 Pixel Clock - 140 MHz
 Secondary GTF - Not Supported

(108-125) Detailed Timing / Descriptor Block 4:

Monitor Name: VX924

(126) No Extension EDID Block(s)

(127) CheckSum OK

Digital EDID

128 BYTES OF EDID CODE:

	0	1	2	3	4	5	6	7	8	9
0	00	FF	FF	FF	FF	FF	FF	00	5A	63
10	1C	0F	01	01	01	01	01	0F	01	03
20	80	26	1E	78	2E	68	75	A2	5A	49
30	9F	23	13	50	54	BF	EF	80	81	80
40	71	4F	61	59	45	59	31	59	31	0A
50	01	01	01	01	30	2A	00	98	51	00
60	2A	40	30	70	13	00	78	2D	11	00
70	00	1E	00	00	00	FF	00	50	53	33
80	30	35	30	31	30	30	30	30	31	0A
90	00	00	00	FD	00	32	55	1E	52	0E
100	00	0A	20	20	20	20	20	20	00	00
110	00	FC	00	56	58	39	32	34	0A	20
120	20	20	20	20	20	20	00	28		

-
- (08-09) ID Manufacturer Name = VSC
(11-10) Product ID Code = 0F1C
(12-15) Last 5 Digits of Serial Number = Not Used
(16) Week of Manufacture = 01
(17) Year of Manufacture = 2005
(10-17) Complete Serial Number = See Descriptor Block
(18) EDID Version Number = 1
(19) EDID Revision Number = 3
(20) VIDEO INPUT DEFINITION:
Digital Signal
Non - VESA DFP 1.x Compatible
(21) Maximum Horizontal Image Size = 380 mm
(22) Maximum Vertical Image Size = 300 mm
(23) Display Gamma = 2.20
(24) Power Management and Supported Feature(s):
Active Off/Very Low Power, Standard Default Color Space,
Preferred Timing Mode
Display Type = R/G/B Color
(25-34) CHROMA INFO:
Red X - 0.634 Green X - 0.287 Blue X - 0.138 White X - 0.313
Red Y - 0.354 Green Y - 0.621 Blue Y - 0.077 White Y - 0.329
(35) ESTABLISHED TIMING I:
720 X 400 @ 70Hz (IBM,VGA)
640 X 480 @ 60Hz (IBM,VGA)
640 X 480 @ 67Hz (Apple,Mac II)
640 X 480 @ 72Hz (VESA)
640 X 480 @ 75Hz (VESA)
800 X 600 @ 56Hz (VESA)
800 X 600 @ 60Hz (VESA)

- (36) ESTABLISHED TIMING II:
 800 X 600 @ 72Hz (VESA)
 800 X 600 @ 75Hz (VESA)
 832 X 624 @ 75Hz (Apple,Mac II)
 1024 X 768 @ 60Hz (VESA)
 1024 X 768 @ 70Hz (VESA)
 1024 X 768 @ 75Hz (VESA)
 1280 X 1024 @ 75Hz (VESA)
- (37) Manufacturer's Reserved Timing:
 1152 X 870 @ 75Hz (Apple,Mac II)
- (38-53) Standard Timing Identification:
 1280 X 1024 @60Hz
 1152 X 864 @75Hz
 1024 X 768 @85Hz
 800 X 600 @85Hz
 640 X 480 @85Hz
 640 X 400 @70Hz
 Not Used
 Not Used

(54-71) Detailed Timing / Descriptor Block 1:
 1280x1024 Pixel Clock: 108.00 MHz

	Horizontal Image Size: 376 mm	Vertical Image Size: 301 mm
	Refreshed Mode: Non-Interlaced	Normal Display - No Stereo
Horizontal:	Active Time: 1280 pixels	Blanking Time: 408 pixels
	Sync Offset: 48 pixels	Sync Pulse Width: 112 pixels
	Border: 0 pixels	Frequency: 63.98 KHz
Vertical:	Active Time: 1024 lines	Blanking Time: 42 lines
	Sync Offset: 1 lines	Sync Pulse Width: 3 lines
	Border: 0 lines	Frequency: 60.02 Hz

Digital Separate, Horizontal Polarity (+) Vertical Polarity (+)

(72-89) Detailed Timing / Descriptor Block 2:
 Monitor Serial Number:
 PS3050100001

(90-107) Detailed Timing / Descriptor Block 3:
 Monitor Range Limits:
 Min Vertical Freq - 50 Hz
 Max Vertical Freq - 85 Hz
 Min Horiz. Freq - 30 KHz
 Max Horiz. Freq - 82 KHz
 Pixel Clock - 140 MHz
 Secondary GTF - Not Supported

(108-125) Detailed Timing / Descriptor Block 4:
 Monitor Name: VX924

(126) No Extension EDID Block(s)

(127) CheckSum OK

6. THEORY OF OPERATION

This section describes the function of the LCD monitor per functional block.

This monitor includes MB board, power board and button board.

6.1 MB BOARD

The MB board is a two-layer, single-grounded design with ground and internal planes provided. DC power from the power board enters the board through a 6P connector. The other connector on the board is for the button board. The VGA cable is a signal cable that carries the video, sync and DDC signals from the PC VGA adapter. This system board consists of 4 functional areas: flat panel controller, MCU with flash ROM, and power regulators.

6.1.1 Flat panel controller: RTD2523(U7)

The heart of the system board is the Realtek RTD2523. The RTD2523 is a graphics processing IC designed for LCD monitors. It provides all key IC functions required for LCD displays. On-chip functions include a high-speed triple-ADC, PLL, high scaling engine and OSD controller.

a) Clock Generation:

Crystal Input Clock (TCLK and XTAL). This is the input pair to an internal crystal oscillator and corresponding logic. A 24.576 MHz crystal is recommended.

b) Analog to Digital Converter:

The RTD2523 chip has three ADCs (analog-to-digital converters), one for each color (red, green and blue). The analog RGB signals are connected to RTD2523 as described below.

Pin Name	Pin Number
Red +	37
Red -	38
Green +	34
Green -	35
Blue +	30
Blue -	31

c) OSD: The RTD2523 has a fully programmable, high-quality OSD controller. The on-chip static RAM (4096 words by 24 bits) stores the cell map and the cell definitions.

- d) MTV312 Micro Controller: The MTV312 micro controller (MCU) serves as the system micro controller. It programs the RTD2523 and manages other devices in the system such as the keypad, the backlight, the LED, the audio system and the non-volatile RAM using general purpose input/output (GPIO) pins.

Pin number	Pin Name	Pin Usage
1	P5.2	Key / Power on, off
13	P3.4	NV_RAM (U4) SDA
14	P3.5	NV_RAM (U4) SCL
41	P5.4	Key_down
40	P5.5	Key_right
42	P5.3	Key_up
34	P5.6	Key_left
9	P6.3	Key_mute
2	P5.1	Key_select
27	P6.0	LED_red
26	P6.1	LED_green
16	P6.2	LCD panel power1 on / off control
17	P1.0	Backlight on / off control

- e) Panel Power Sequencing (PANEL_PW12,3) (Pin 16, 18): The MTV312 has two dedicated outputs VDDCTRL1 and 2 (Pin32 and Pin3) to control LCD power sequencing once data and control signals are stable.
- f) Panel interface (Pin73~94): The RTD2523 driver interface is highly programmable. It supports dual bus / dual port for SXGA drivers.

6.1.2 Power Regulator AIC1563 (U2), AIC1117CY (U1,U3): The AIC1563 is a monolithic control IC containing the primary functions required for DC to DC converters. The device consists of an internal temperature compensated reference, a comparator, and a controlled duty cycle oscillator with an active current sense circuit. The desired output voltage is determined by the equation, $Volt = 1.25 (1 + R11 / R12)$. In this case, the output voltage is 5 Volts. The AIC1563 is a low dropout positive adjustable regulator with minimum of 1A output current capability, so it is well suited to serve as a 3.3 V or 2.5 V regulator.

6.1.3 Power Regulator AIC1117CY (U1,U3): The AIC1117CY is a monolithic control IC containing the primary functions required for DC to DC converters. The device consists of an internal temperature compensated reference, a comparator, and a controlled duty cycle oscillator with an active current sense circuit. The desired output voltage is determined by the equation, $Volt = 1.25 (1 + R17 / R15)$. In this case, the output voltage is 2.5 Volts for panel power.

6.2 Power (Inverter) Board

This is a specific power (inverter) board for VX912 monitor with output of 40W / 12V / 3.5A. It provides 12 VDC to drive the four cold cathode fluorescence tubes in the backlight.

6.2.1 The inverter's electrical specification is described below.

Input	Rated Input Voltage	12Vdc
	Input Voltage Range	11.4 ~ 12.6 Vdc
	Input Current	<2A
	On / Off control Voltage	2~3.3 for on, 0~1 for off
Output	Rated Output Strike-on Voltage	1500Vrms
	Rated Output Voltage	710Vrms at 7mA
	Rate Output Frequency	40~50KHz
	Rated Output Current	7~8 mA

6.2.2 Power

This is a general purpose AC / DC adapter which converts 90~240 Vac to a stabilized DC voltage: 12 Volts, with a rated output current of 4.16A. The electrical specification is described below.

	Rated Input Voltage	90~240 Vac, 50 / 60Hz
	Operation Input Voltage	90~260 Vac, 47 ~ 63Hz
	Input Current	<1.5A
	Inrush Current	<100A@120Vac
	Standby Input Voltage	12Vdc
	Output Voltage Regulation	+/-5%
	Output Ripple & Noise	120mVp-p
	Rate Output Current	<3.5A
	Turn-on delay	<3secs

5. Adjustment Procedure

OSD Function Menu

A. When in Analog Input Mode

1. Main Menu

Press the [1] (Menu) button to enter the Main Menu:

Press the [▲] button to highlight the previous item or the [▼] button to highlight the next item.

Press the [1] (Menu) button to exit the Main Menu.

(1) Auto Image Adjust Page:

Press the [2] button to execute the auto image adjust function.

Press the [1] button to exit the page.

(2) Contrast/Brightness Page:

Press the [2] button to enter the contrast adjustment page.

Press the [1] button to exit the page.

1) Contrast Item

Press the [▲] button to increase the contrast.

Press the [▼] button to decrease the contrast.

Press the [2] button to enter the brightness adjustment page.

Press the [1] button to exit the page.

2) Brightness Item

Press the [▲] button to increase the brightness.

Press the [▼] button to decrease the brightness.

Press the [2] button to enter the contrast adjustment page.

Press the [1] button to exit the page.

(3) Input Select Page:

Press the [2] button to switch to digital input mode.

(4) Color Adjust Page:

Press the [2] button to enter the color adjustment page.

Press the [1] button to exit the page.

Press the [▲] button to highlight the previous item or the [▼] button to highlight the next item.

1) sRGB Item

2) 9300K Item

3) 6500K Item

4) 5400K Item

Press the [2] button to select the currently highlighted item.

Press the [1] button to exit the currently highlighted item.

5) User Color Item

Press the [2] button to enter the user color page.

Press the [1] button to exit the page.

Red, Green, Blue Options:

Press the [2] button to cycle among the colors.

Press the [1] button to exit the page.

Press the [▲] button to increase the selected color level.

Press the [▼] button to decrease the selected color level.

(5) Information Page:

Press the [2] button to enter the information page.
Press the [1] button to exit the information page.

(6) Manual Image Adjust Page:

Press the [2] button to enter the manual image adjustment page.
Press the [1] button to exit the page.
Press the [▲] button to highlight the previous item or the [▼] button to highlight the next item.

1) H./V. Position Item

Press the [2] button to enter the horizontal/vertical position adjustment page.
Press the [1] button to exit the page.

a) Horizontal Position:

Press the [2] button to enter the vertical position adjustment page.
Press the [1] button to exit the page.
Press the [▲] button to shift the image to the right.
Press the [▼] button to shift the image to the left.

b) Vertical Position:

Press the [2] button to return to the horizontal position adjustment page.
Press the [1] button to exit the page.
Press the [▲] button to shift the image upward.
Press the [▼] button to shift the image downward.

2) Horizontal Size Item

Press the [2] button to enter the horizontal size adjustment page.
Press the [1] button to exit the page.
Press the [▲] button to make the image wider.
Press the [▼] button to make the image narrower.

3) Fine tune Item

Press the [2] button to enter the fine tuning page.
Press the [1] button to exit the page.
Press “[▲]” Button to adjust character position in one direction.
Press “[▼]” Button to adjust character position in the other direction.

4) Sharpness Item

Press the [2] button to enter the sharpness adjustment page.
Press the [1] button to exit the page.
Press “[▲]” Button to increase image sharpness.
Press “[▼]” Button to decrease image sharpness.

(7) Setup Menu Page:

Press the [2] button to enter the setup menu page.
Press the [1] button to exit the page.
Press the [▲] button to highlight the previous item or the [▼] button to highlight the next item.

1) Language Select Item

Press the [2] button to enter the language selection page.

Press the [1] button to exit the page.
Press the [▲] button to highlight the previous item or the [▼] button to highlight the next item.

English, French... Option

Press the [2] button to select the language.
Press the [1] button to exit the page.

2) Resolution Notice Item

Press the [2] button to enter the resolution notice page.
Press the [1] button to exit the page.

Enable, Disable Option

Press the [2] button to select the highlighted option.
Press the [1] button to exit the page.
Press the [▲] button to highlight the previous option or the [▼] button to highlight the next option.

3) OSD Position Item

Press the [2] button to enter the OSD position adjustment page.
Press the [1] button to exit the page.

a) Horizontal Position Option

Press the [2] button to enter the vertical position adjustment page.
Press the [1] button to exit the page.
Press the [▲] button to shift the menu to the right.
Press the [▼] button to shift the menu to the left.

b) Vertical Position Option:

Press the [2] button to enter the horizontal position adjustment page.
Press the [1] button to exit the page.
Press the [▲] button to shift the menu upward.
Press the [▼] button to shift the menu downward.

4) OSD Time Out Item

Press the [2] button to enter the OSD time out adjustment page.
Press the [1] button to exit the page.
Press the [▲] button to increase the OSD time out.
Press the [▼] button to decrease the OSD time out.

5) OSD Background Item

Press the [2] button to enter the OSD background selection page.
Press the [1] button to exit the page.
Enable, Disable Option
Press the [▲] button to highlight the previous option or the [▼] button to highlight the next option.
Press the [2] button to select the highlighted option.
Press the [1] button to exit the page.

(8) Memory Recall Page

Press the [2] button to execute the memory recall function.
Press the [1] button to exit the page.

2. Other Menu:

This “shortcut” menu is directly accessible without bringing up the OSD.

(1) Contrast Dialog

Press the [▲] or [▼] button to enter the Contrast Dialog.

Press the [1] button to exit the Contrast Dialog.

Press the [2] button to enter the Brightness Dialog.

Press the [▲] button to increase the contrast.

Press the [▼] button to decrease the contrast.

(2) Brightness Dialog

Press the [▲] or [▼] button to enter the Brightness Dialog.

Press the [1] button to exit the Brightness Dialog.

Press the [2] button to enter the Contrast Dialog.

Press the [▲] button to increase the brightness.

Press the [▼] button to decrease the brightness.

(3) Analog/Digital Dialog

Press the [2] button to toggle between analog and digital modes.

B. When in Digital Input Mode

1. Main Menu

Press the [1] (Menu) button to enter the Main Menu:

Press the [▲] button to highlight the previous item or the [▼] button to highlight the next item.

Press the [1] (Menu) button to exit the Main Menu.

(1) Auto Image Adjust Page:

Press the [2] button to execute the auto image adjust function.

Press the [1] button to exit the page.

(2) Contrast/Brightness Page:

Press the [2] button to enter the contrast adjustment page.

Press the [1] button to exit the page.

1) Contrast Item

Press the [▲] button to increase the contrast.

Press the [▼] button to decrease the contrast.

Press the [2] button to enter the brightness adjustment page.

Press the [1] button to exit the page.

2) Brightness Item

Press the [▲] button to increase the brightness.

Press the [▼] button to decrease the brightness.

Press the [2] button to enter the contrast adjustment page.

Press the [1] button to exit the page.

(3) Input Select Page:

Press the [2] button to switch to analog input mode.

(4) Color Adjust Page:

Press the [2] button to enter the color adjustment page.

Press the [1] button to exit the page.
Press the [▲] button to highlight the previous item or the [▼] button to highlight the next item.

- 1) **sRGB Item**
- 2) **9300K Item**
- 3) **6500K Item**
- 4) **5400K Item**

Press the [2] button to select the currently highlighted item.
Press the [1] button to exit the currently highlighted item.

- 5) **User Color Item**

Press the [2] button to enter the user color page.
Press the [1] button to exit the page.

Red, Green, Blue Options:

Press the [2] button to cycle among the colors.
Press the [1] button to exit the page.
Press the [▲] button to increase the selected color level.
Press the [▼] button to decrease the selected color level.

- (5) **Information Page:**

Press the [2] button to enter the information page.
Press the [1] button to exit the information page.

- (6) **Manual Image Adjust Page:**

Press the [2] button to enter the manual image adjustment page.
Press the [1] button to exit the page.
Press the [▲] button to highlight the previous item or the [▼] button to highlight the next item.

- 1) **Sharpness Item**

Press the [2] button to enter the sharpness adjustment page.
Press the [1] button to exit the page.
Press “[▲]” Button to increase image sharpness.
Press “[▼]” Button to decrease image sharpness.

- (7) **Setup Menu Page:**

Press the [2] button to enter the setup menu page.
Press the [1] button to exit the page.
Press the [▲] button to highlight the previous item or the [▼] button to highlight the next item.

- 1) **Language Select Item**

Press the [2] button to enter the language selection page.
Press the [1] button to exit the page.
Press the [▲] button to highlight the previous item or the [▼] button to highlight the next item.

English, French... Option

Press the [2] button to select the language.
Press the [1] button to exit the page.

- 2) **Resolution Notice Item**

Press the [2] button to enter the resolution notice page.

Press the [1] button to exit the page.

Enable, Disable Option

Press the [2] button to select the highlighted option.

Press the [1] button to exit the page.

Press the [▲] button to highlight the previous option or the [▼] button to highlight the next option.

3) OSD Position Item

Press the [2] button to enter the OSD position adjustment page.

Press the [1] button to exit the page.

a) Horizontal Position Option

Press the [2] button to enter the vertical position adjustment page.

Press the [1] button to exit the page.

Press the [▲] button to shift the menu to the right.

Press the [▼] button to shift the menu to the left.

b) Vertical Position Option:

Press the [2] button to enter the horizontal position adjustment page.

Press the [1] button to exit the page.

Press the [▲] button to shift the menu upward.

Press the [▼] button to shift the menu downward.

4) OSD Time Out Item

Press the [2] button to enter the OSD time out adjustment page.

Press the [1] button to exit the page.

Press the [▲] button to increase the OSD time out.

Press the [▼] button to decrease the OSD time out.

5) OSD Background Item

Press the [2] button to enter the OSD background selection page.

Press the [1] button to exit the page.

Enable, Disable Option

Press the [▲] button to highlight the previous option or the [▼] button to highlight the next option.

Press the [2] button to select the highlighted option.

Press the [1] button to exit the page.

(8) Memory Recall Page

Press the [2] button to execute the memory recall function.

Press the [1] button to exit the page.

2. Other Menu:

This “shortcut” menu is directly accessible without bringing up the OSD.

(1) Contrast Dialog

Press the [▲] or [▼] button to enter the Contrast Dialog.

Press the [1] button to exit the Contrast Dialog.

Press the [2] button to enter the Brightness Dialog.

Press the [▲] button to increase the contrast.

Press the [▼] button to decrease the contrast.

(2) Brightness Dialog

- Press the [▲] or [▼] button to enter the Brightness Dialog.
- Press the [1] button to exit the Brightness Dialog.
- Press the [2] button to enter the Contrast Dialog.
- Press the [▲] button to increase the brightness.
- Press the [▼] button to decrease the brightness.

(3) Analog/Digital Dialog

- Press the [2] button to toggle between analog and digital modes.

C. Other Information

When the “No Signal” or “Out of Range” messages appear:

If no input signal is detected, the “No Signal” message will appear in the center of the screen.

If the V-Sync signal rate is greater than 85Hz or its resolution is greater than SXGA, the “Out of Range” message will appear in the center of the screen.

Activating Factory Mode and Burn Mode:

While the device is in standby, press the [2] button, then press the power button to enter Factory Mode. While Factory Mode is active, an additional menu page titled “Factory Menu” will be accessible. Press the [2] button to enter the Factory Menu page, then press the [2] button to enter Burn Mode.

When Installing a New Main Board

1. Enter Factory Mode.
2. Use a PC or chrom to send a 32-tone gray scale signal to the monitor.
3. Select “Auto Color”

1. Function test

- (1) Test equipment
Color video signal and pattern generator (or PC with SXGV resolution)
- (2) Test condition
Before function testing and alignment, the unit must warm up for at least 30 minutes under the following conditions:
 - 1. Room temperature;
 - 2. With full-white screen, RGB, black pattern;
 - 3. With cycled display modes.

2. Test display modes

Item	Timing	Analog	Digital
1	640 x 350 @ 70Hz, 31.5kHz	Yes	Yes
2	640 x 400 @ 60Hz, 31.5kHz	Yes	Yes
3	640 x 400 @ 70Hz, 31.5kHz	Yes	Yes
4	640 x 480 @ 50Hz, 24.7kHz	No	No
5	640 x 480 @ 60Hz, 31.5kHz	Yes	Yes
6	640 x 480 @ 67Hz, 35.0kHz	Yes	Yes
7	640 x 480 @ 72Hz, 37.9kHz	Yes	Yes
8	640 x 480 @ 75Hz, 37.5kHz	Yes	Yes
9	640 x 480 @ 85Hz, 43.27kHz	Yes	Yes
10	720 x 400 @ 70Hz, 31.5kHz	Yes	Yes
11	800 x 600 @ 56Hz, 35.1kHz	Yes	Yes
12	800 x 600 @ 60Hz, 37.9kHz	Yes	Yes
13	800 x 600 @ 75Hz, 46.9kHz	Yes	Yes
14	800 x 600 @ 72Hz, 48.1kHz	Yes	Yes
15	800 x 600 @ 85Hz, 53.7kHz	Yes	Yes
16	832 x 624 @ 75Hz, 49.7kHz	Yes	Yes
17	1024 x 768 @ 60Hz, 48.4kHz	Yes	Yes
18	1024 x 768 @ 70Hz, 56.5kHz	Yes	Yes
19	1024 x 768 @ 72Hz, 58.1kHz	Yes	Yes
20	1024 x 768 @ 75Hz, 60.0kHz	Yes	Yes
21	1024 x 768 @ 85Hz, 68.67kHz	Yes	Yes
22	1152 x 864 @ 75Hz, 67.5kHz	Yes	Yes
23	1152 x 870 @ 75Hz, 68.7kHz	Yes	Yes
24	1280 x 1024 @ 60Hz, 63.4kHz	Yes	Yes
25	1280 x 1024 @ 75Hz, 79.97kHz	Yes	Yes
26	1280x 720 @ 60Hz, 45kHz (HDTV)	Yes	Yes

3. Test pattern

Item	Test condition	Pattern	Specification	Remark
1	Frequency & performance	Cross-hatch pattern	No noise is allowed, all colors must be clear	Pattern 1
2	Monitor saturation	16-gray scale pattern	3 to 4 levels must be saturated when brightness and contrast are set to 100%	Pattern 2
3	RGB color performance	RGB color	Check the color temperature of RGB signal color	Pattern 3, 4, 5
4	Sub-pixel defect	RGB color	Check for sub-pixel defects	Pattern 3, 4, 5
5	Full white	Full white	Check the brightness and contrast ratio, and check for bright pixel defects	Pattern 6
6	Full black	Full black		Pattern 7
7.	5-cycle pattern	5-cycle pattern	Check the BU	Pattern 8
8.	1-dot pattern	1-dot pattern	Check the flicker	Pattern 9

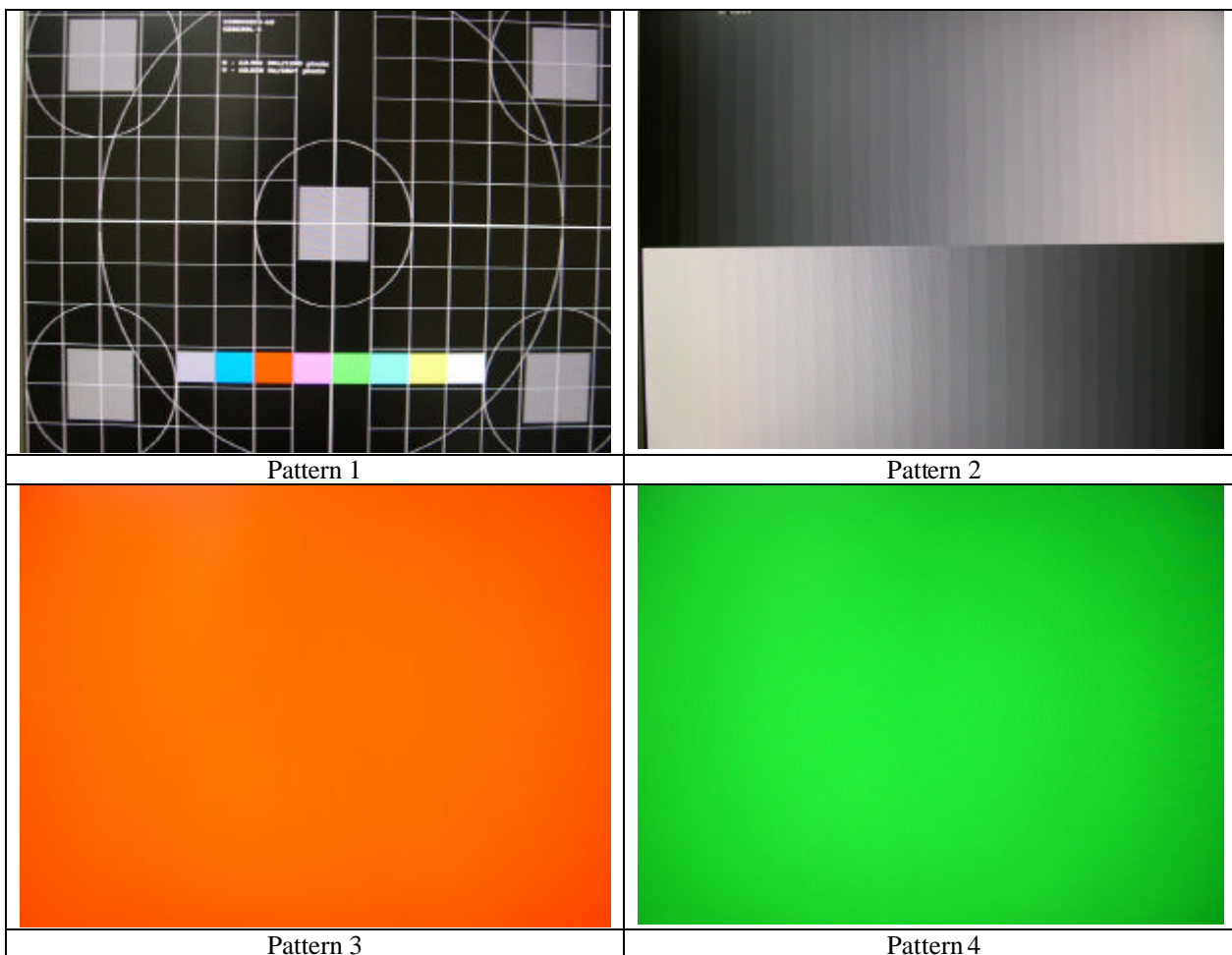



6. Firmware update procedure :

When examining a monitor, please check whether the firmware version is the latest. If not, please follow the procedure below to upgrade to the latest version.

1. Equipment needed :

- VX924
- PC (Personal computer)
- LPT cable
- Fixture (LM5ISP)
- Firmware upgrade program



2. Connection :

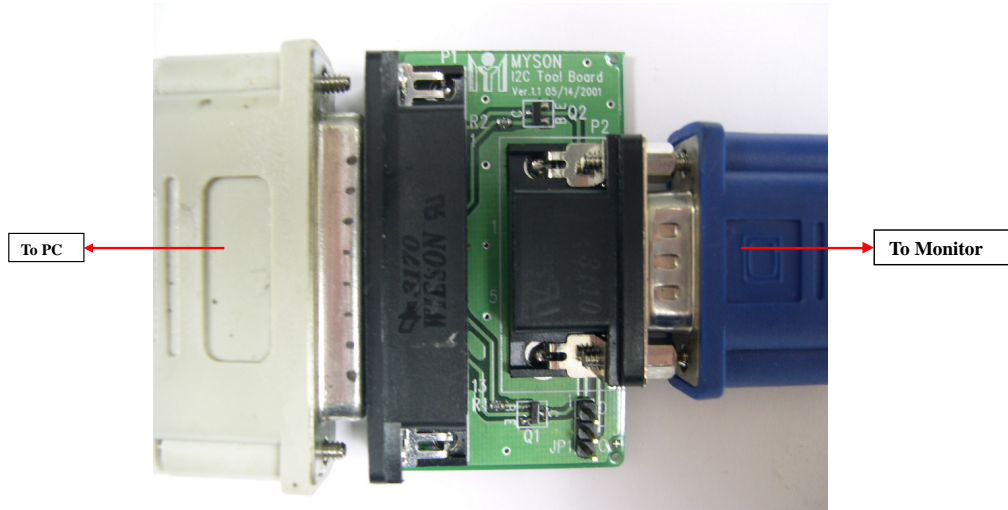

Appendix A : How to install the software for ISP:

1. To set up ISP environment:

Hardware: PC or notebook, parallel (printer) cable, ISP tooling.

Software: If OS is Win2000 or WinXP, please install "PORT95NT.exe".

In order to ensure that the system can execute the ISP program, please adjust the BIOS settings in the PC or notebook as shown in Fig 0.0.

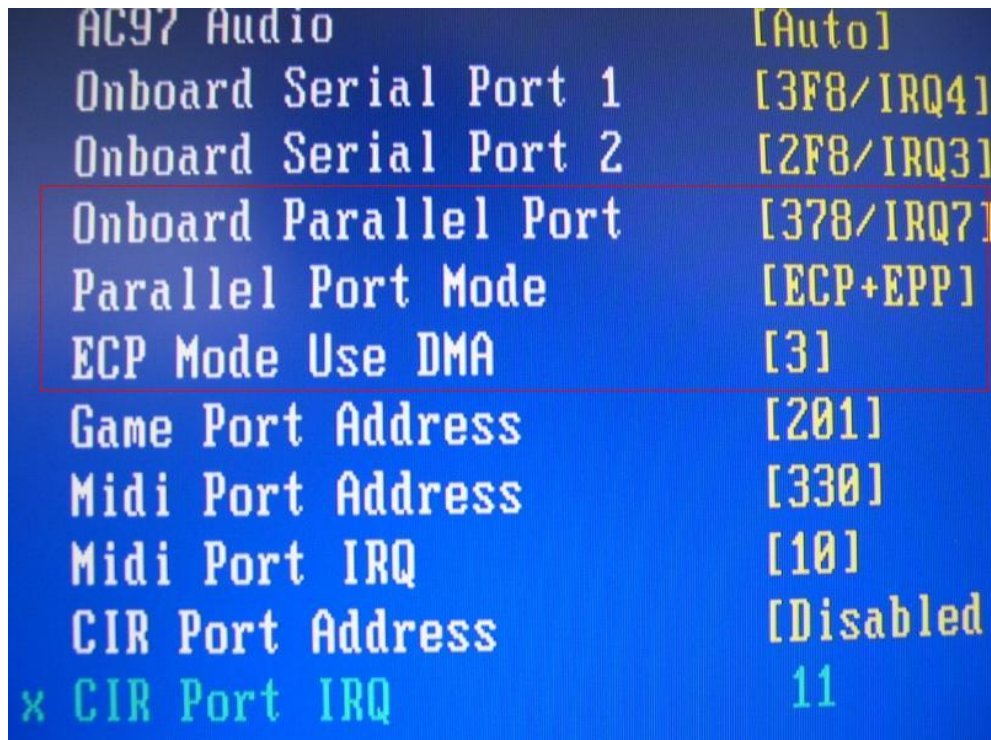

Fig 0.0

2. Double-click the "PORT95NT.exe" icon in Windows and install the program; see Fig 0.1.

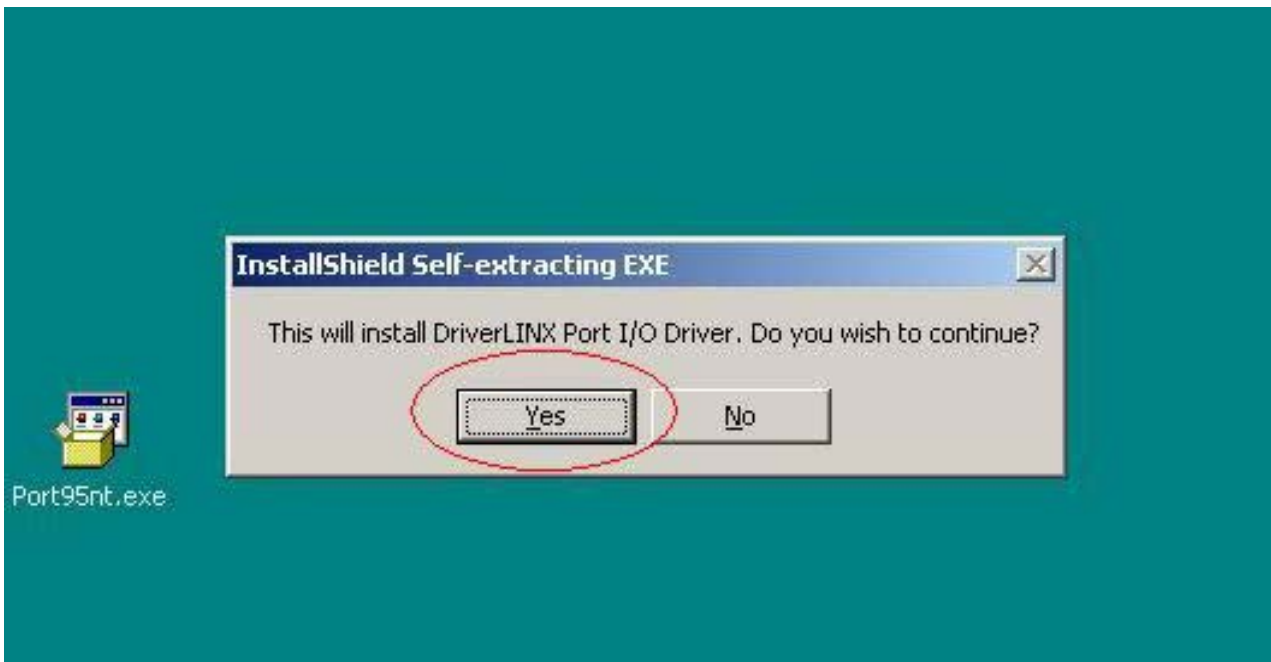

Fig 0.1

3. Continue through the installation process by pressing "Next" four times; see Fig. 0.2.

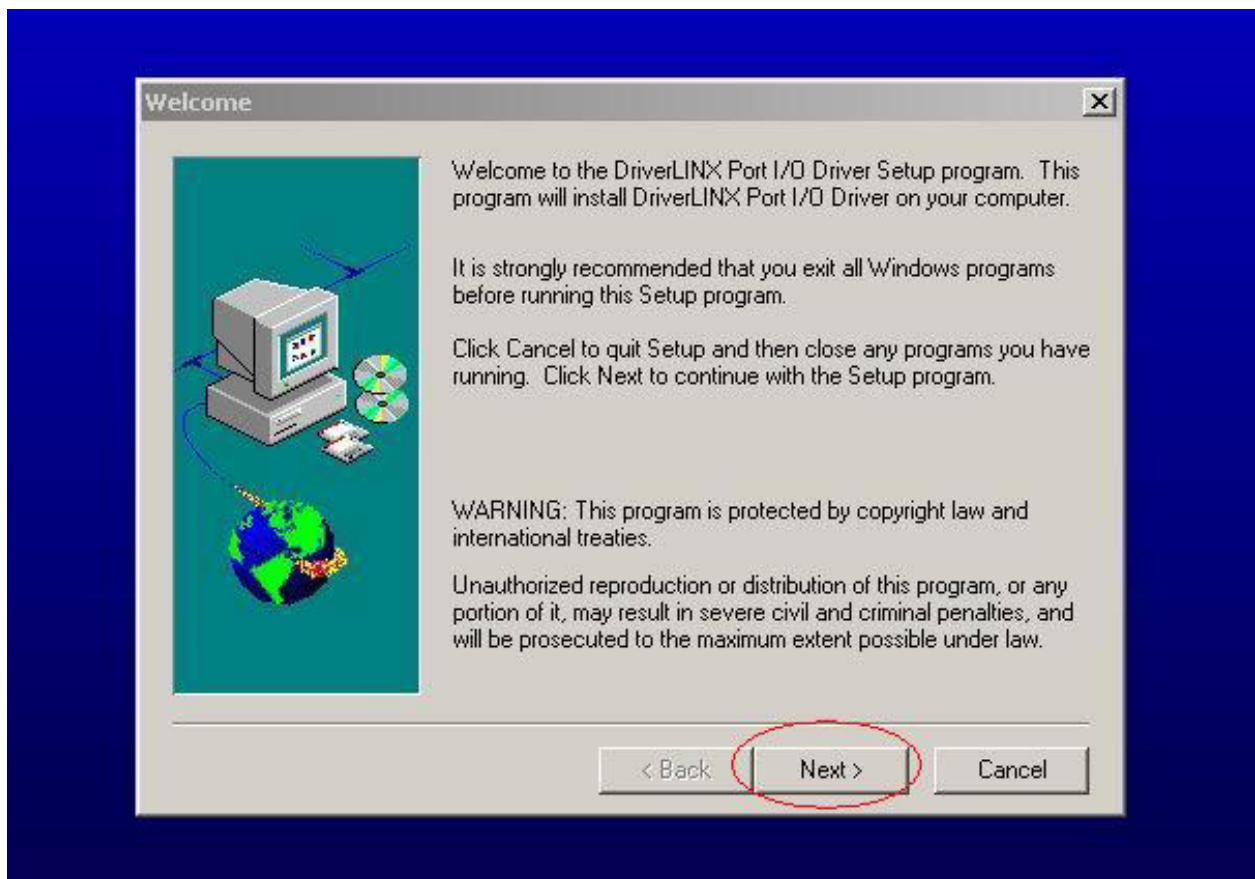

Fig. 0.2

4. Choose "Typical" then press "Next;" see Fig. 0.3.

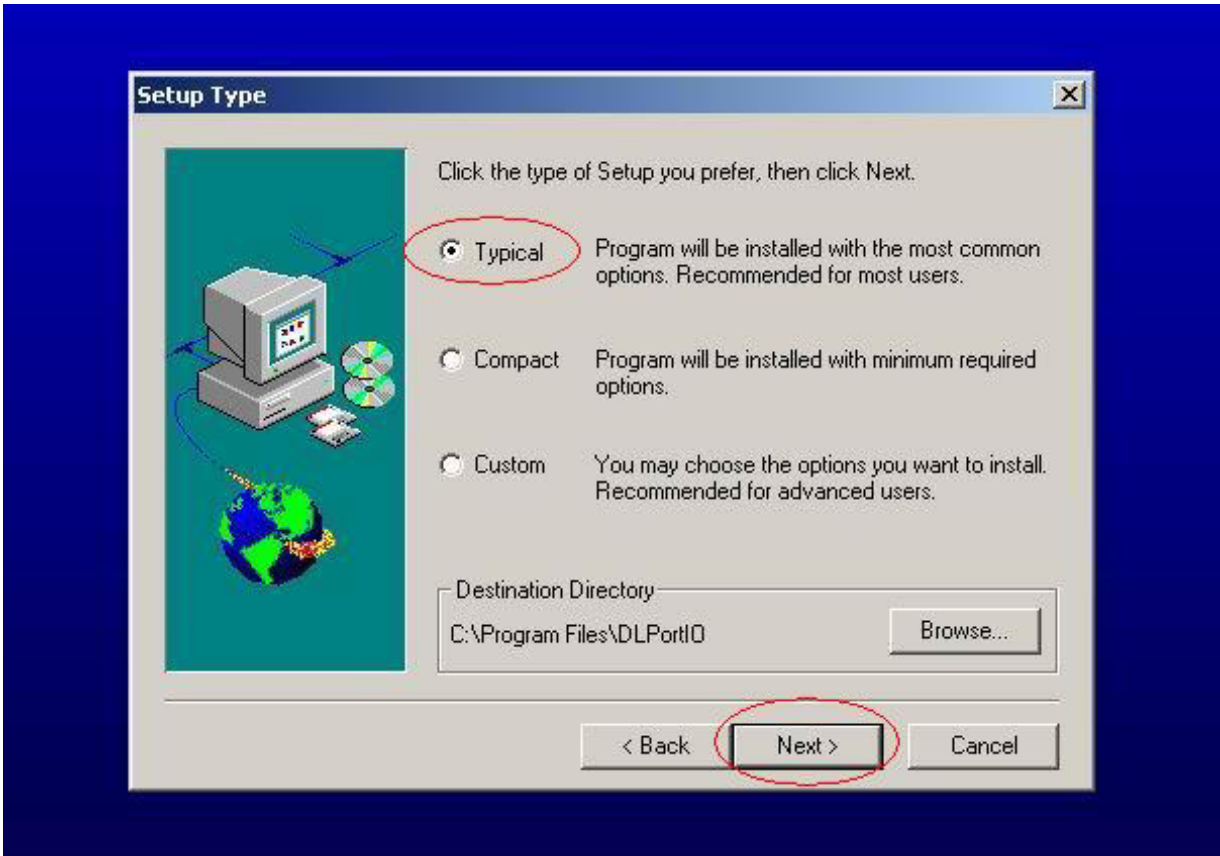

Fig. 0.3

5. Continue through the installation process by pressing "Next" four times; see Fig. 0.4.

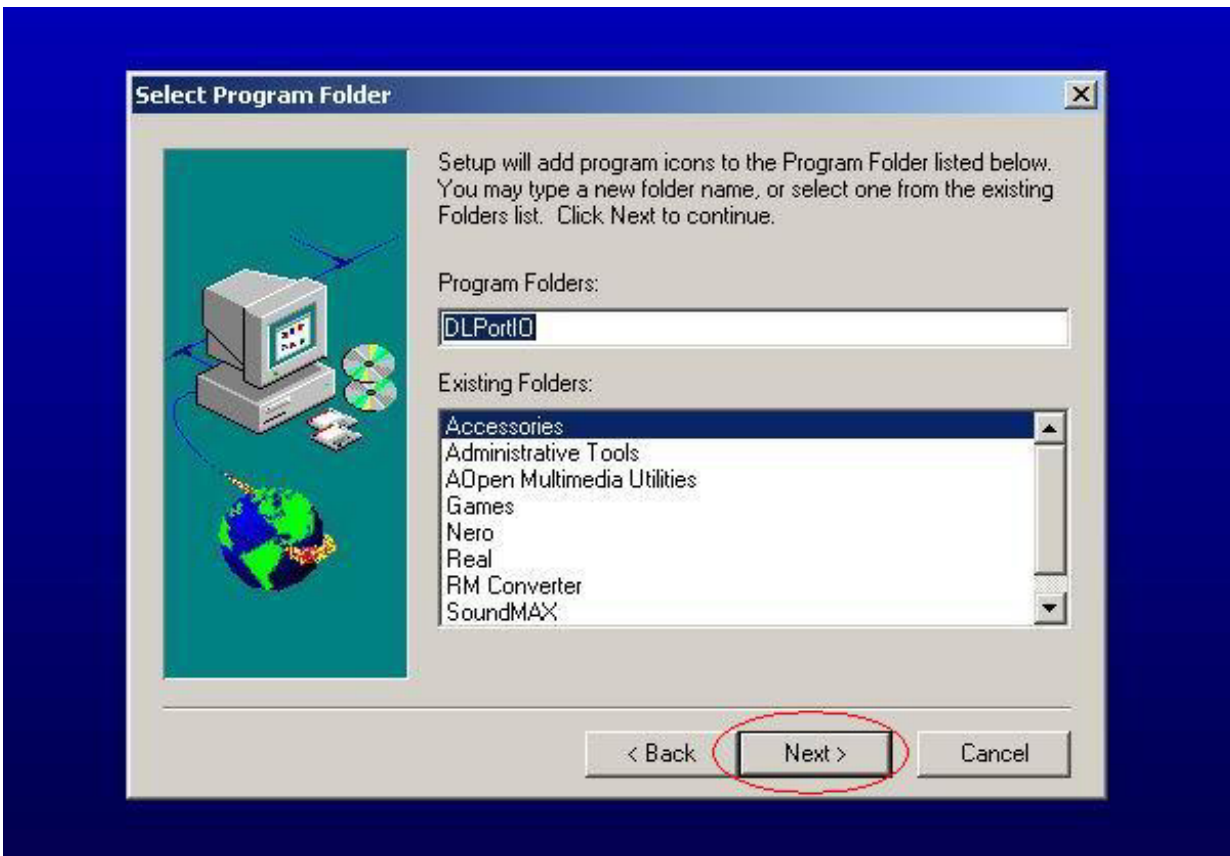

Fig. 0.4

6. When the installation is complete, restart the PC or notebook; see Fig 0.5.

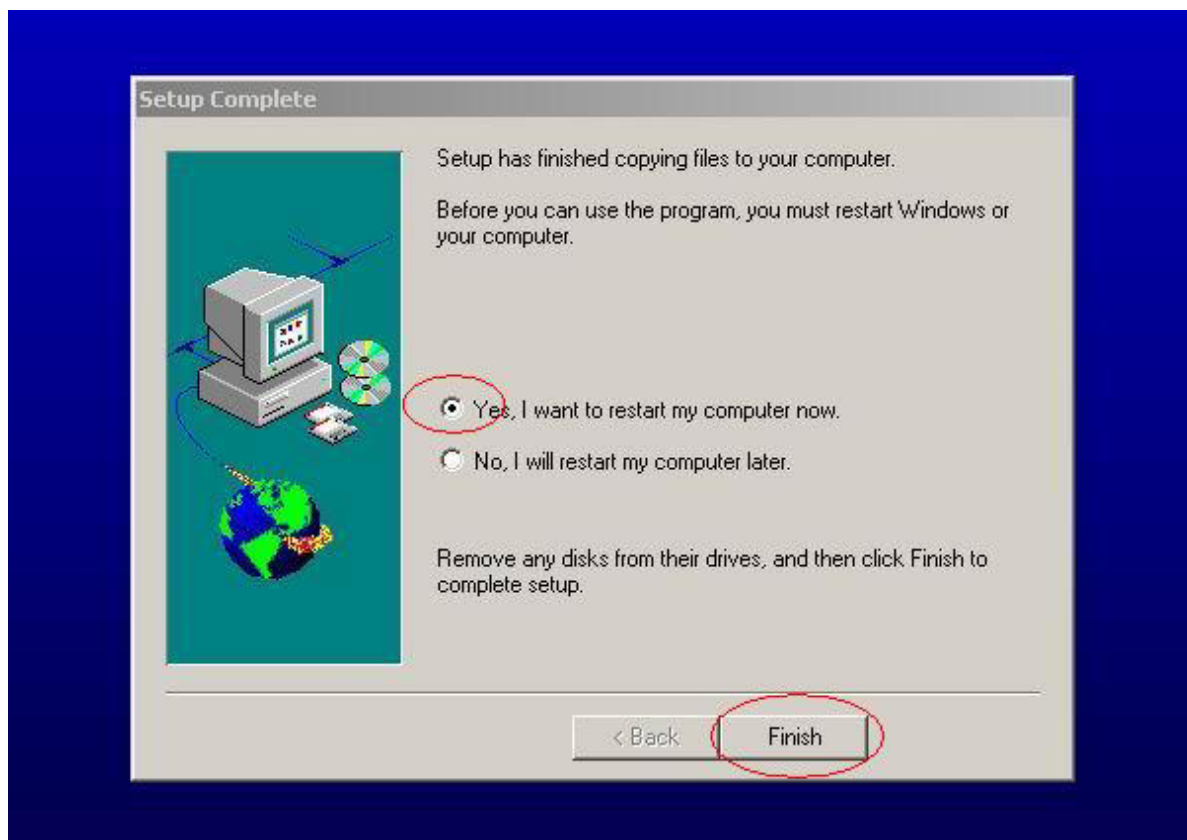

Fig. 0.5

Install ISP

1. The user may download the ISP driver and PORT95NT installation package from the Myson Century website (www.myson.com).
2. The files extracted from the ZIP file are listed in Fig 1.0. Double-click setup.exe to install.

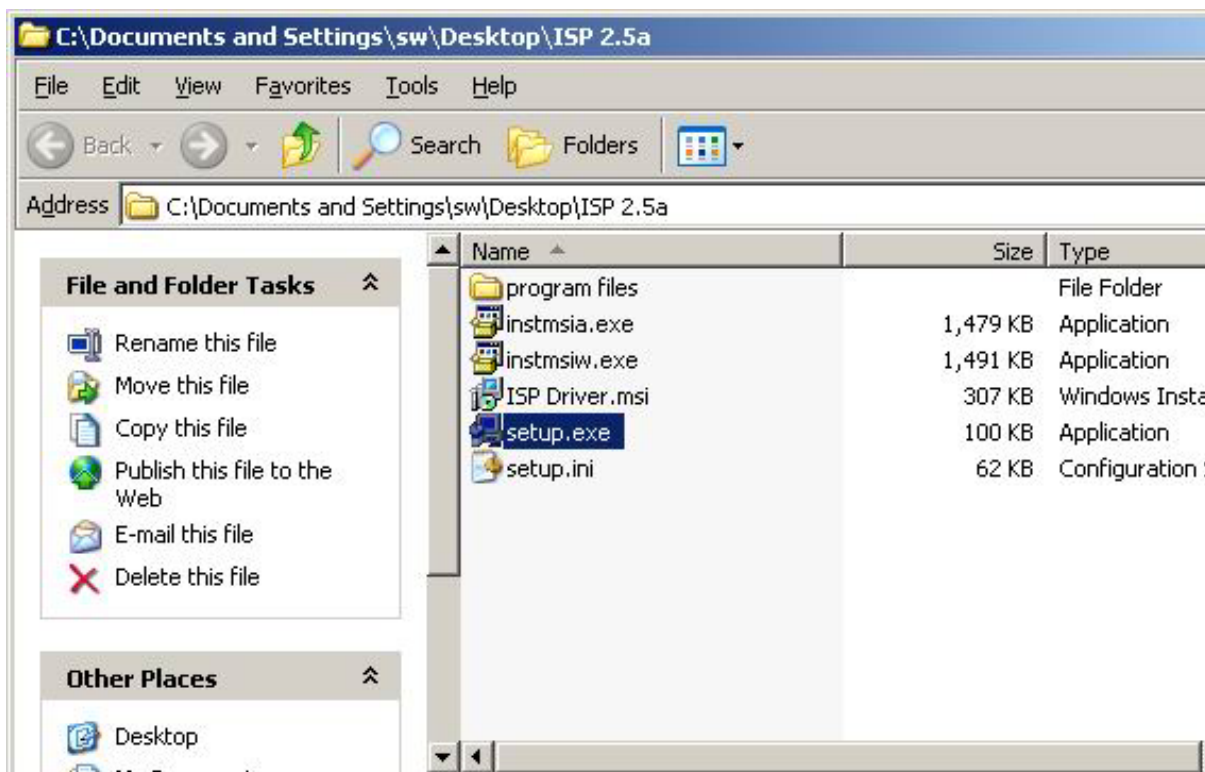

Fig 1.0

3. Press the "Next" button to continue; see Fig 1.1.



Fig 1.1

4. Press the "Change" button to change the install path if desired, and then press the "Next" button to continue; see Fig 1.2.



Fig 1.2

5. Press the "Install" button to continue; see Fig 1.3.

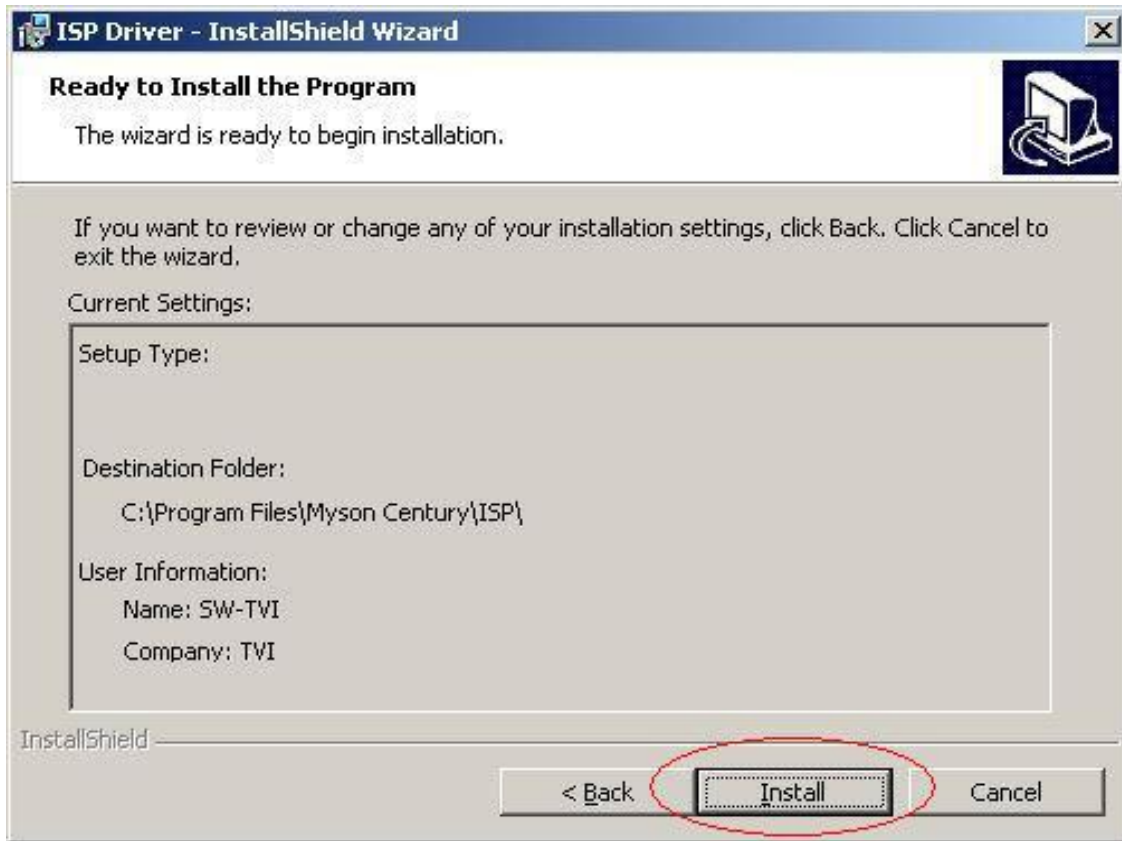

Fig. 1.3

6. When installation has finished, press the "Finish" button; see Fig 1.4.

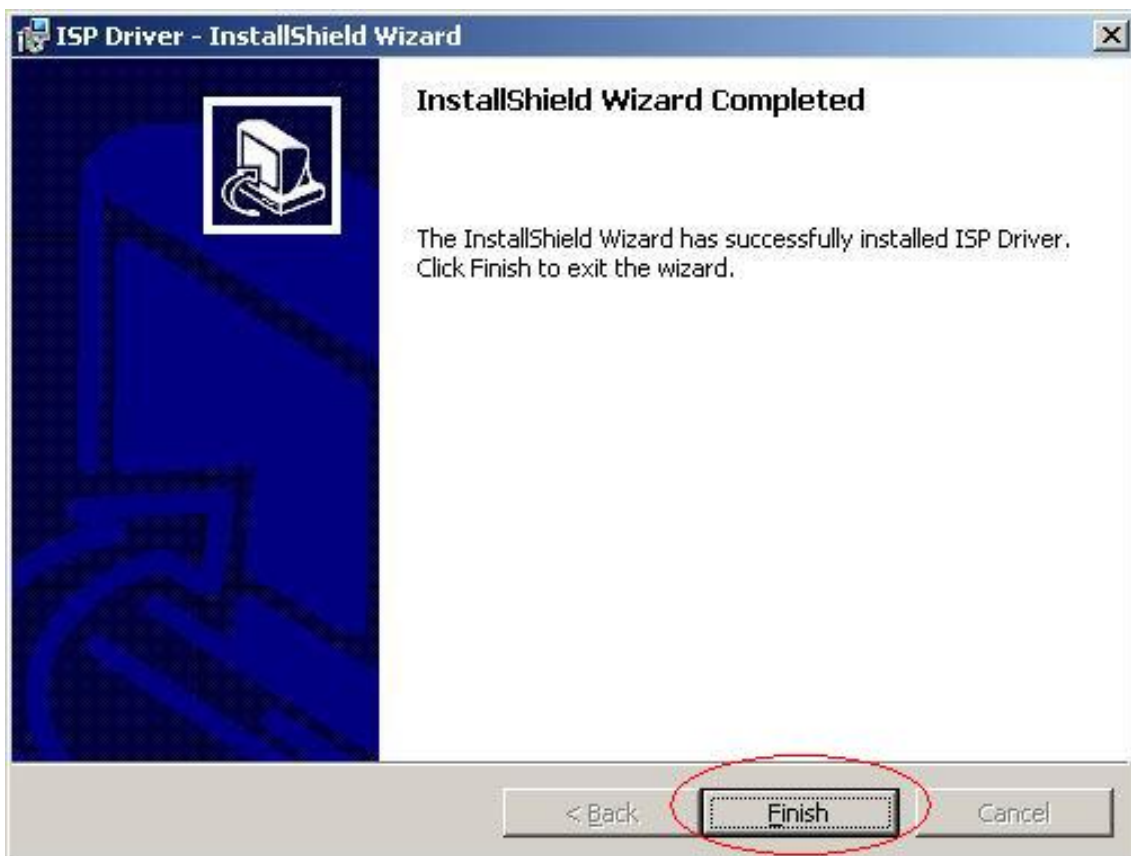

Fig. 1.4

Appendix B: How to use software to upgrade the BIOS:

1. After installation, shortcuts may be found in the settings path or the program menu (default setting); see Fig 2.1.

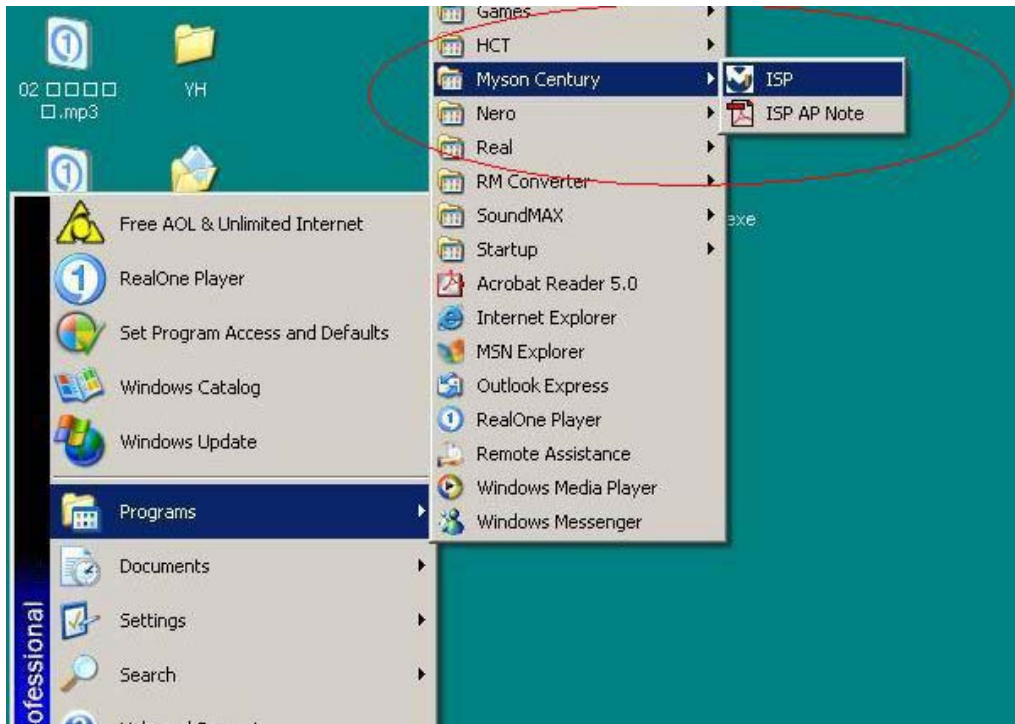

Fig. 2.1

2. The security file is a key to use ISP functions; press the "OK" button. See Fig 2.2.



Fig. 2.2

3. The warning shown in Fig. 2.3 is used to remind the user that a CPU rate that differs from IIC protocol may cause the ISP functions to fail; press the "OK" button.



Fig. 2.3

4. As shown in Fig. 2.4, press the "Create Security File" button to key in a security code, and use the slider bar to adjust the speed of the IIC bus.

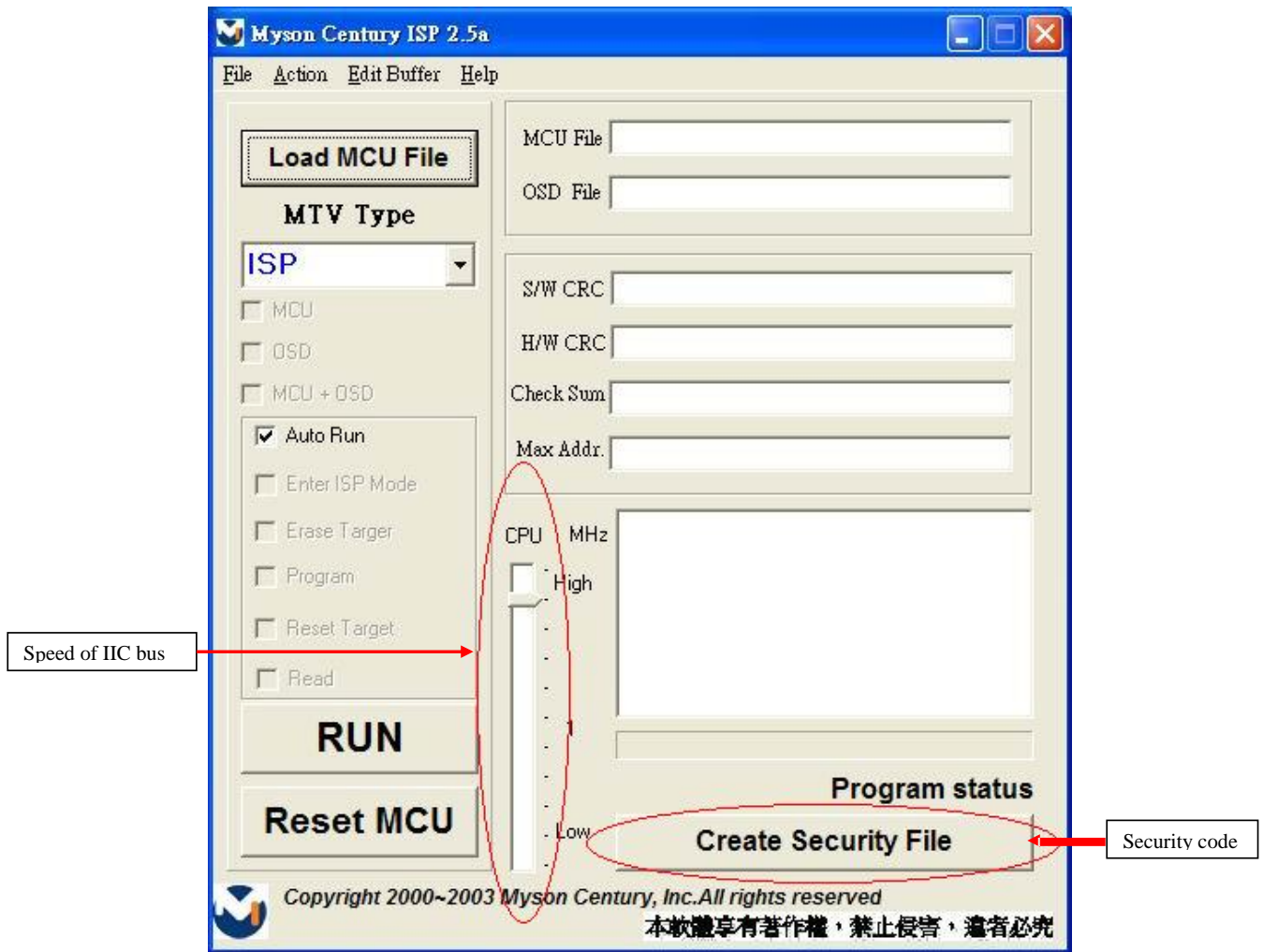

Fig. 2.4

5. Fig 2.5 shows the settings for the ISP software's security code. It requires two command numbers, and the commands must be keyed in sequentially: 7C, 4C, 77. The command numbers and commands must be set by the user while coding. For more details, please refer to section 6 boot code of ISP.

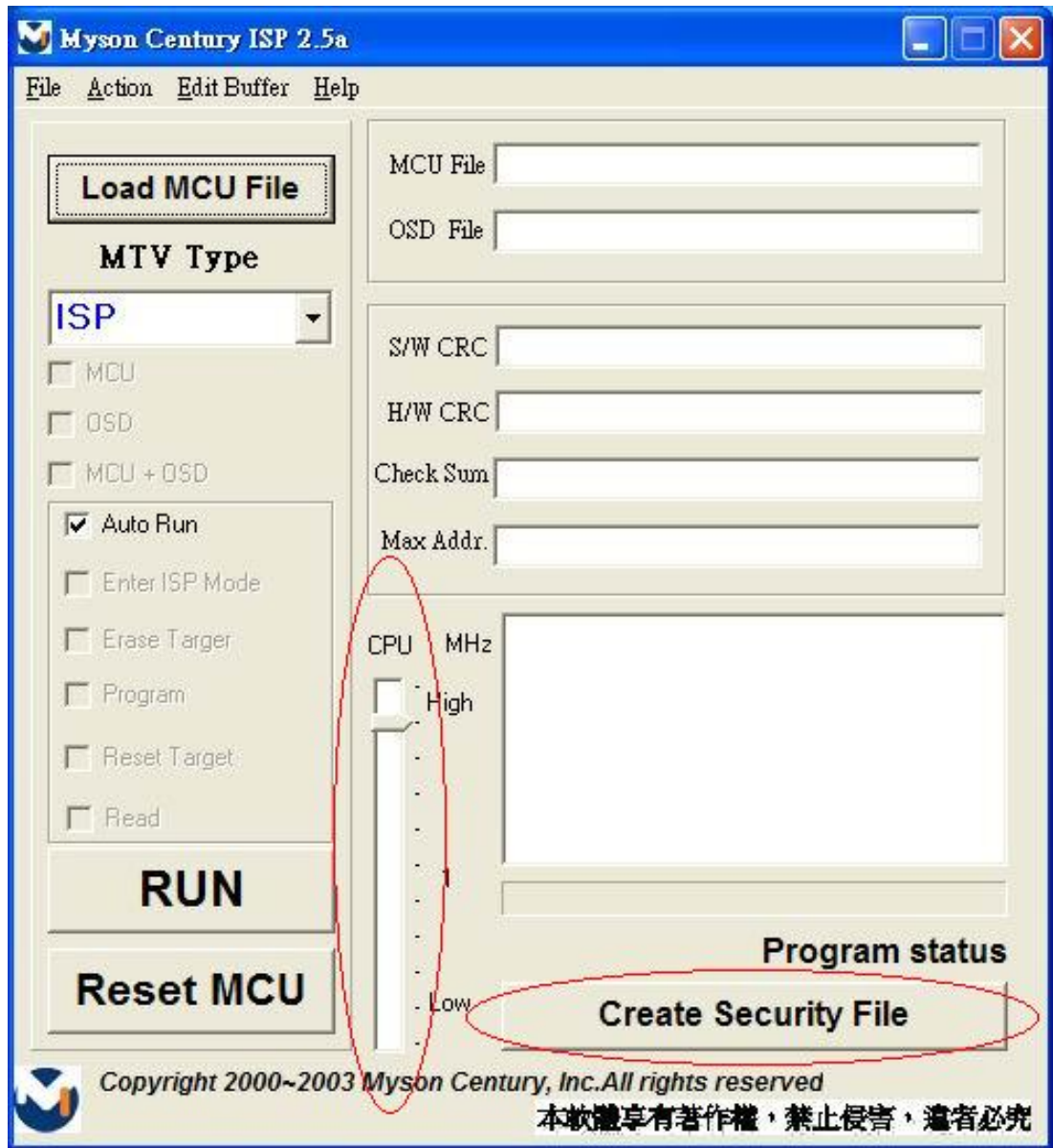

Fig. 2.5

Appendix C: Using ISP to program MCU

1. As shown in Fig. 3.1, select the MTV type first, load the binary or intel hex file to be programmed into the MCU, click "OK," then press the "RUN" button.

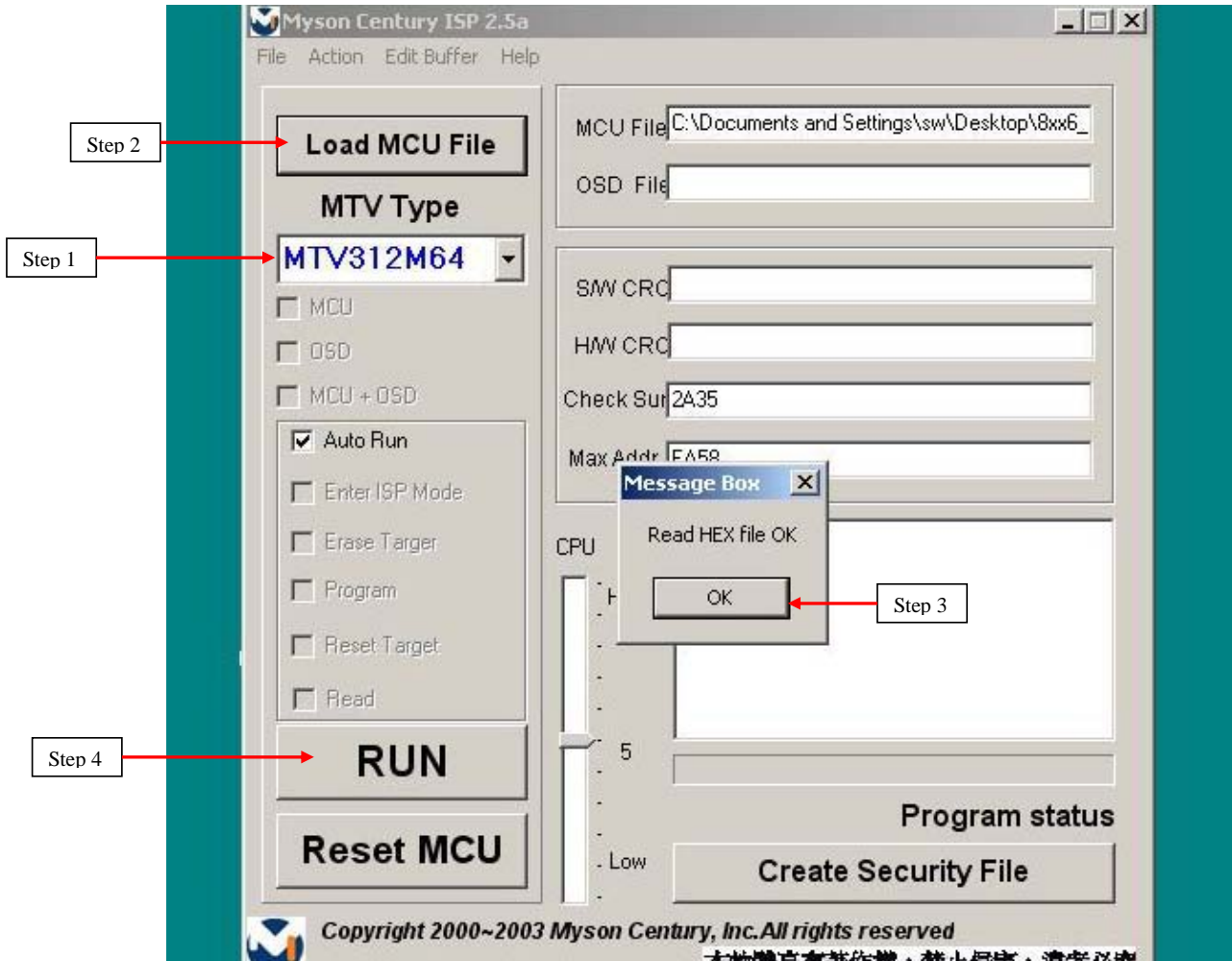

Fig. 3.1

2. If the user changes the MTV type, the file must be loaded again, as the previously loaded file will be cleared.
3. CRC (cyclic redundancy check): the host can check the result in the CRC register instead of reading every byte in flash. The Check MCU CRC OK message indicates that the host has verified the program's CRC; see Fig.3.2.

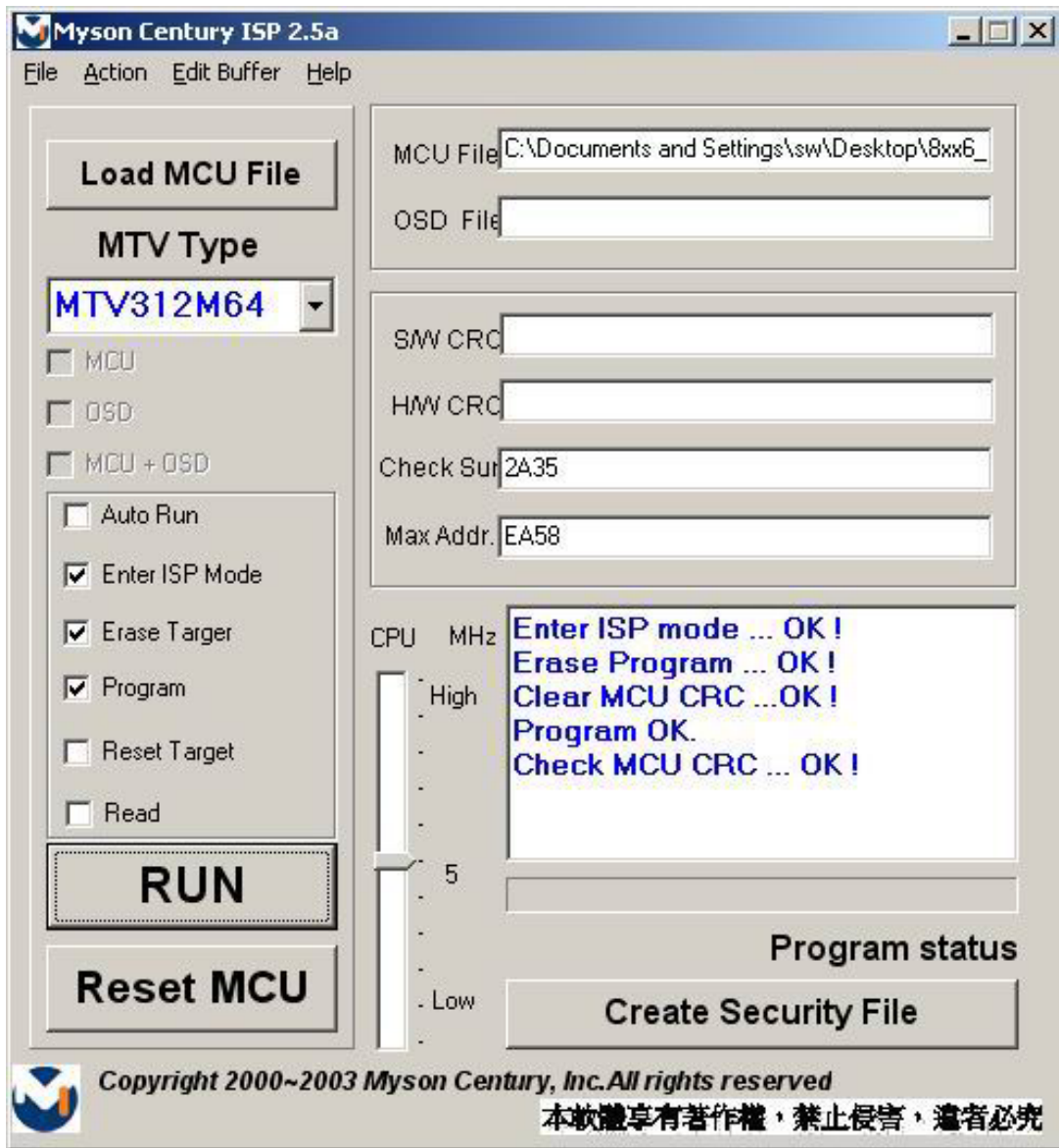
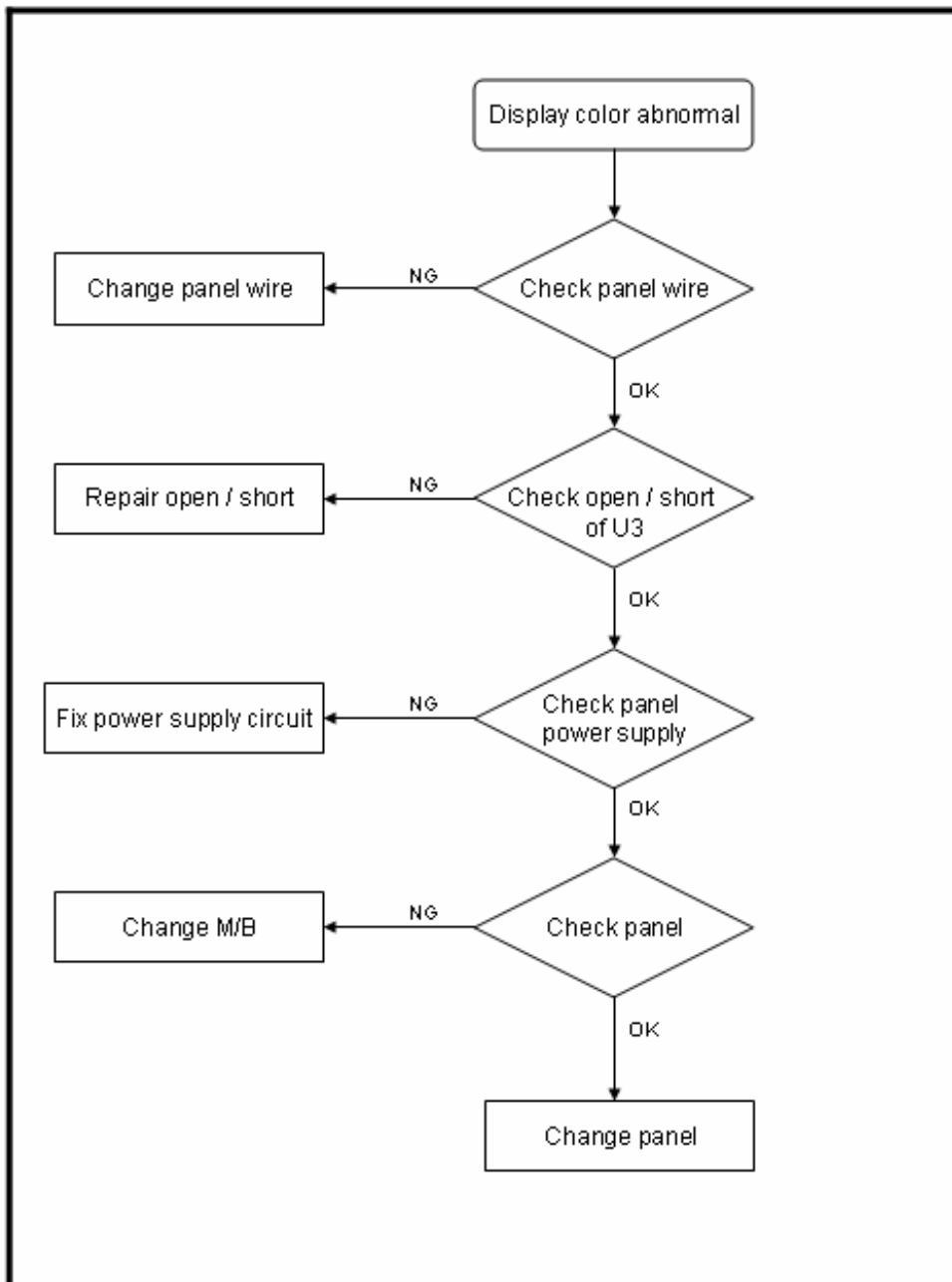

Fig. 3.2

6. Troubleshooting Flow Chart

1. Display color abnormal:



2. Monitor cannot power on

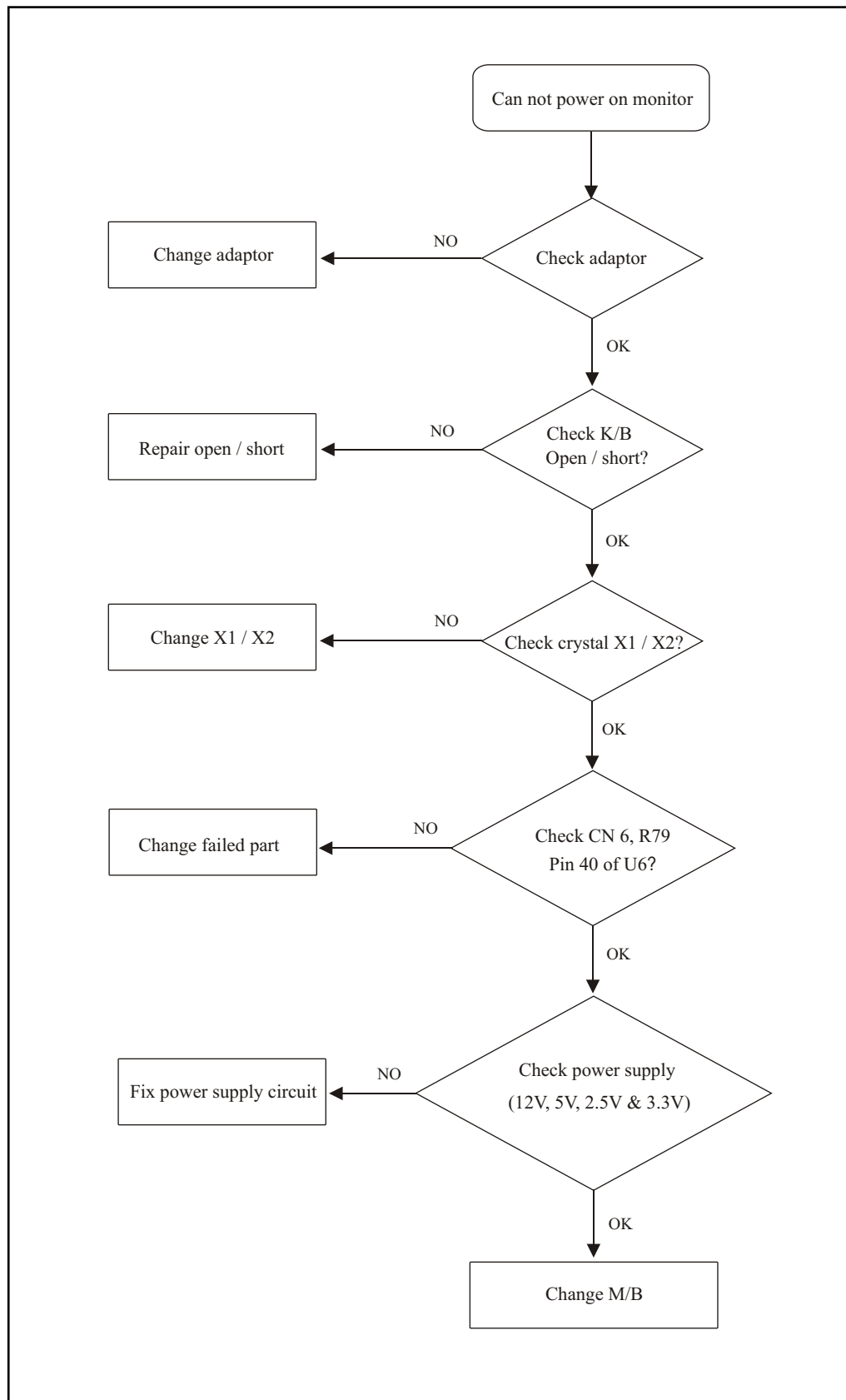

3. Monitor white screen

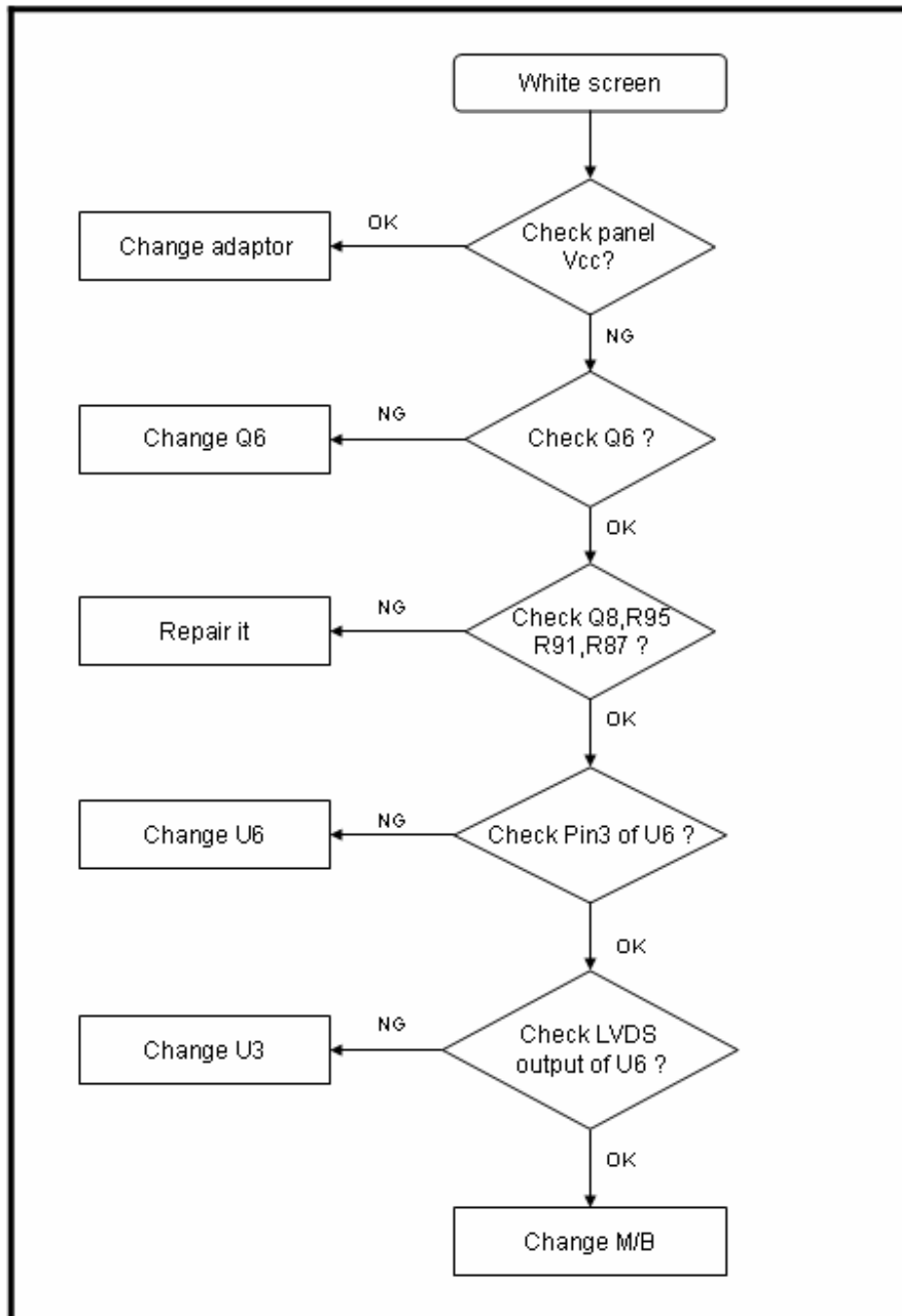

4. Monitor black screen

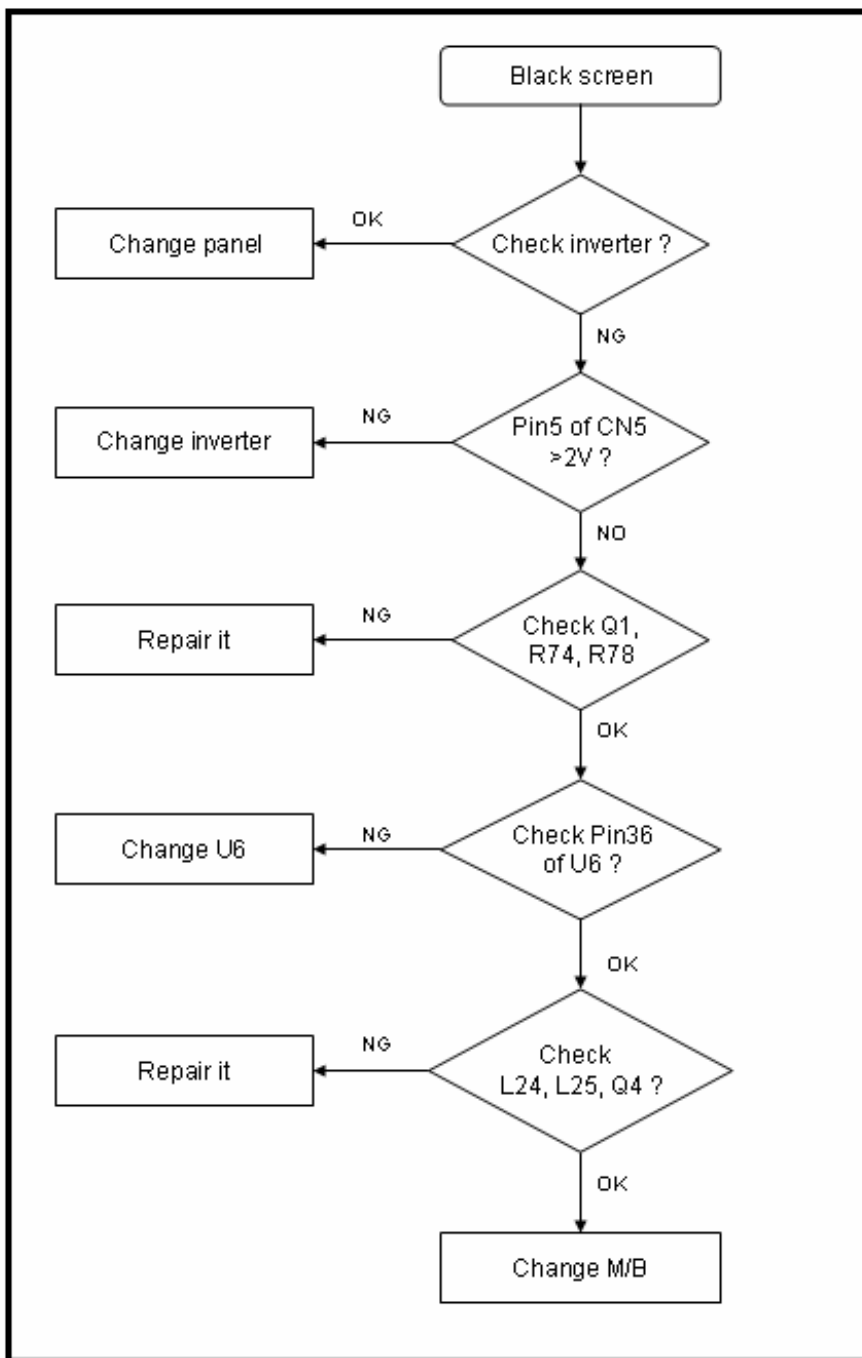

5. Analog input: always shows NO SIGNAL:

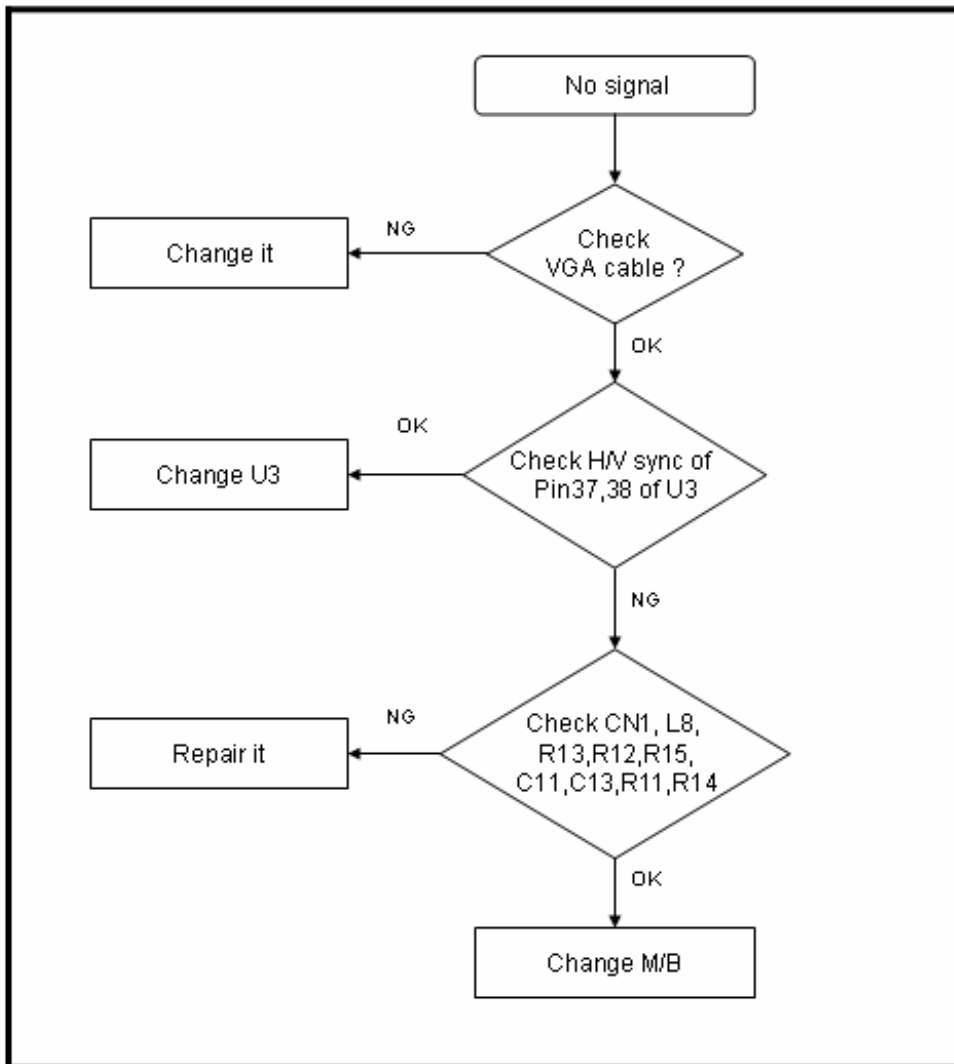

6. Digital input: always shows NO SIGNAL

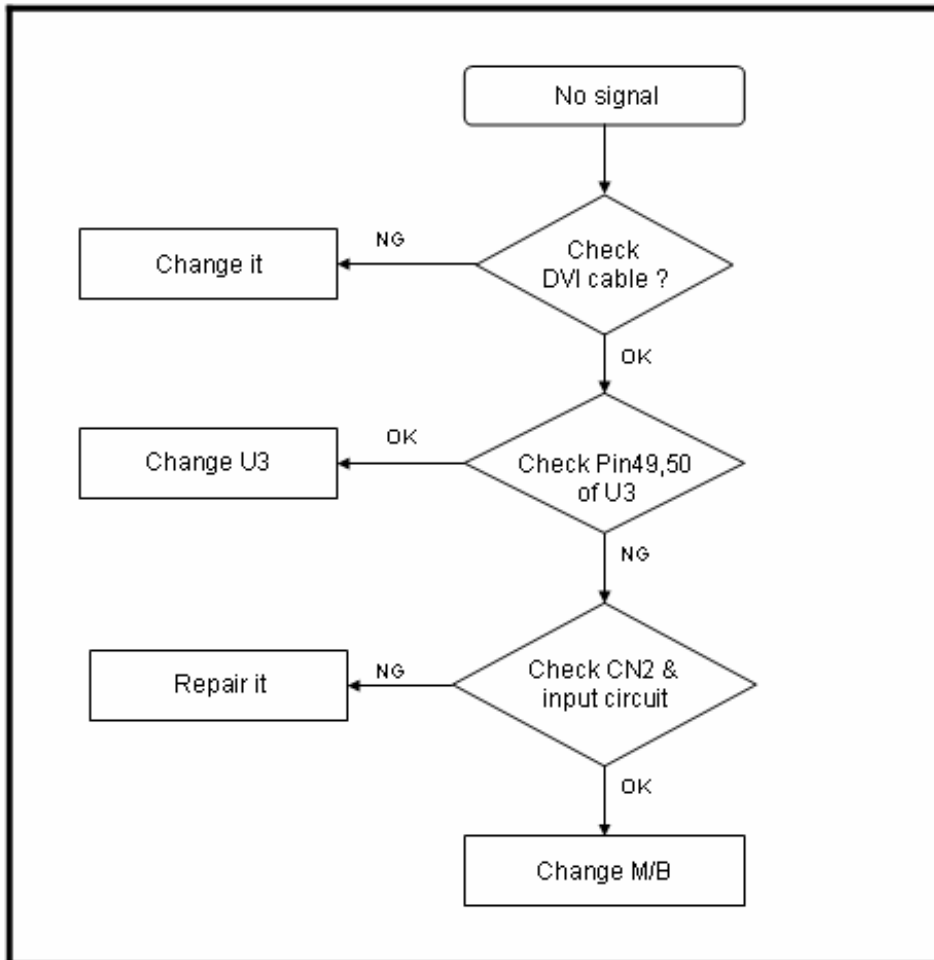

7. Recommended Spare Parts List

RECOMMENDED SPARE PARTS LIST (VX924-1)

ViewSonic Model Number: VS10162-3W

Rev: 1a

Item	Description	ECR/ECN	ViewSonic P/N	Ref. P/N	Location	Q'ty
1	PC Board Assembly:	main board	B-00002519	29L9IMB00E5	main board	1
2		Over driver board	B-00002520	22L9V0B0005	Over driver board	
3		Power board	B-PS-0204-0076	AS02B012D24	power board	1
4	Cabinets:	Back cover assy	C-BC-0302-0626	33L9VBCVS05	back cover	1
5		Front bezel assy	C-FP-0301-1033	32L9VFBVS07	front bezel ass'y	1
6		Stand cover rear	C-00001778	EBL9V002015	stand cover	1
7	Cables:	Cable for MB-B/B (8P/10P, Rev.1A)	M-MS-0808-9398	DDL7VDTH009	M/B-B/B cable	1
8		Cable for MB-LCD (30P, Rev.1A)	CB-00002525	DD0L9VLC015	MB-LCD cable	1
9		Cable for MB-over driver	CB-00002522	DD0L9V0B000	MB-over driver cable	
10		VGA cable	M-MS-0808-9399	DDL7VDPC005	VGA cable	1
11	Documentation:	User manual + CD wizard	DC-00002523	HGL9V0011019	user's manual	1
12	Electronic	19" AUO TFT LCD panel	E-00001775	AAM190EN129	LCD panel	1
13	Hardware:	Screw M4*6-I (BN)(NYLOK)	M-SCW-0824-6859	MM40060IL69	Screw	4
14		Screw M3.0*4.0-I(NI)	M-SCW-0824-6802	MM30040IBJ9	Screw	14
15	Miscellaneous:	LCD film L9V	M-MS-0808-9682	JXL9V001010	LCD panel film	1
16		4ms sticker	M-00002524	HCL9V007018	4ms sticker on carton	1
17	Packing Material:	Carton	P-00002521	HFL9V007011	carton	1
18		End cap (L)	P-FM-0602-0896	HBL9V001019	cushion	1
19		End cap (R)	P-FM-0602-0897	HBL9V002015	cushion	1
20		EPE bags	M-MS-0808-9817	HAL9V002014	EPE bags	1

BOM LIST (VX924-1)

ViewSonic Model Number: VS10162-3W

Rev: 1a

Item	ViewSonic P/N	Ref. P/N	Description	Location	Q'ty
1	#N/A	1L9VDZAVS92	L9V LCD MONITOR(L9VDA-5,AU VX924)US		
2	B-00002519	29L9IMB00E5	L9I M/B ASSY(FOR L9VDA-5 REALTEK,2523)AU		1
3	#N/A	39L9IDP0056	L9I M/B DIP ASSY(L9VDA-5 REALTEK)2523		1
4	#N/A	41L9ISS0053	L9I M/B S/S ASSY(L9VDA-5 REALTEK)2523		1
5	#N/A	CC62204MD23	CAP ELEC 22U 25V(+20%,105C,5*11,2000HR)	C34,C46,C50,C53,C59,C84,EC1,EC2,EC3,EC5,EC6	11
6	#N/A	CC622L4MD06	CAP ELEC DIP 22U 25V(+20%,105C,5*11)LXN	C34,C46,C50,C53,C59,C84,EC1,EC2,EC3,EC5,EC6	11
7	#N/A	CC71004MD68	CAP ELEC 100U 25V +20%,105C,6*11,LESR	C70	1
8	#N/A	CC710L4MD08	CAP ELEC 100U 25V(+20%,105C,6*11)LXN	C70	1
9	#N/A	CC73303MD51	CAP ELEC 330U 16V(+20%,105C,8*11,2000HR)	C6,EC4	2
10	E-L-0407-1563	DC04725K002	CHOKE COIL 47UH(2.5A,+10%,T07473)	L2	1
11	#N/A	BG624576031	CRYSTAL DIP 24.576MHZ(30PPM,20PF,49/US)	Y1	1
12	#N/A	BG611059319	CRYSTAL DIP 11.0592MHZ(+30PPM,49/US)	Y2	1
13	#N/A	DFHD06MR247	CONN DIP HEADER 6P 2R MR(P2.5,H6.0)	CN1	1
14	#N/A	DFDS15FR050	CONN D-SUB 15P 3R FR,P1.15,H12.55,NO SRW	CN2	1
15	#N/A	DFDI30FR049	CONN DVI-I DIP30P 3R FR(P1.905,H10.04)	CN4	1
16	M-MS-0808-9809	DFHD30MR259	CONN DIP HEADER 30P 2R MR(P2.0,H4.0)	CN5	1
17	M-MS-0808-9810	DFHD10MR316	CONN DIP HEADER 10P 1R MR(P2.0,H4.1)	CN6	1
18	#N/A	AZL9VD0A206	L9VDA-5 SW BIOS IMAGE REALTEK(AU)2523		1
19	B-00002520	22L9V0B0005	L9V OVER DRIVER/B ASSY		1
20	#N/A	DA0L9V0B2B8	PCB(OD/B) L9V ODB(2L,85*90MM REV B)		1
21	#N/A	AJ036010F00	IC(208P)LCD OVERDRIVE VTIO3601(LQFP)	U4	1
22	#N/A	AKD24G-K501	IC SDRAM(50P) K4S161622H-TC60 TSOP	U2,U5,U6,U7	4
23	#N/A	AKE24FU0K13	IC FLASH SST25VF512A-33-4C-SAE S08 GP	U3	1
24	#N/A	AL001084013	IC(3P) L1084D(TO-252)	U1	1
25	#N/A	CH41004Z931	CAP CHIP 0.1U,25V(+80-20%,Y5V,0603) GP	C2,C4,C6,C7,C8,C9,C10,C11,C12,C13,C14,C15,C16,C17,C34,C35,C36,C37,C38,C39,C40,C41,C42,C43,C44,C45,C60,C61,C62,C63,C64,C65,C66,C67,C68,C69,C70,C71,C72,C73,C76,C77,C78,C79,C80,C81,C82,C83,C84,C85,C86,C87,C88,C89	54
26	#N/A	CH61001ZA31	CAP CHIP 10U 6.3V(+80%-20%,Y5V,0805)	C1,C3,C5,C18,C19,C21,C22,C23,C24,C32,C33,C58,C59,C74,C75	15
27	#N/A	CJ033084N16	RES ARRAY CHIP 33,1/16W(5%,8P4R)R-PIN	PR1,PR2,PR3,PR4,PR5,PR6,PR7,PR8,PR9,PR10,PR11,PR12,PR13,PR14,PR15,PR16	16
28	#N/A	CS03303J909	RES CHIP 33 1/10W +-5%(0603)	R21	1
29	#N/A	CS11003F902	RESISTOR CHIP 100 1/10W+-1%(0603)	R3,R4,R5,R6,R7,R9,R10,R11,R12,R13	10
30	#N/A	CS12003F905	RESISTOR CHIP 200 1/10W+-1%(0603)	R1	1
31	#N/A	CS13303F909	RESISTOR CHIP 330 1/10W +-1%(0603)	R2	1
32	#N/A	CS31003J908	RES CHIP 10K 1/10W +-5%(0603)	R8	1
33	#N/A	CS21003J906	RES CHIP 1K 1/10W +-5%(0603)	R14	1
34	#N/A	DFHD30MS026	CONN SMD HEADER 30P 2R MS(P2.0,H4.0)	JP1,JP2	2
35	#N/A	CX201209805	EMI FILTER CHIP FBM-11-201209-121A40 GP	L1,L2,L3,L4,L5	5
36	B-CB-0206-0188	23L7VB0034	L7VD BUTTON/B ASSY		1
37	#N/A	DFHD08MR301	CONN DIP HEADER 8P 1R MR(P2.0,H4.1)	CN1	1
38	#N/A	BEYG0013DA3	LED(DIP) YELLOW/GREEN(L-3WYGW)	LED1	1
39	#N/A	DAL7VDTB1A3	PCB(BUTTON) L7VD TL(1L,180*15,REVA)		1
40	#N/A	DHP0002B205	SWITCH PUCH BUTTON(PT-002-B2,50MA,12V)	SW1,SW2,SW3,SW4,SW5	5
41	B-PS-0204-0076	AS02B012D24	ADD/INV_FSP035-1PI01,90-264V REV1A		1
42	#N/A	23L9VLAVS63	L9VDA-5 LCD MOUDLE ASSY(AU,VX924)		1
43	C-FP-0301-1033	32L9VFBVS07	L9V FRONT BEZEL ASSY		1
44	C-00000987	EAL9V001018	BEZEL L9V(EAL9V001,REV3A)		1
45	C-FP-0301-1047	EAL9V002014	MIDDLE BEZEL L9V(EAL9V002,REV3A)		1
46	M-MS-0808-9401	EBL7V028019	LENS L7VD(EBL7V028,REV3A)		1
47	PL-BT-0706-0165	EBL7V027012	CONTROL BUTTON L7VD(EBL7V027,REV3A)		1
48	M-MS-0808-9243	FEL7V003019	LOGO FRONT-VSC-38MM L7VC(FEL7V003,REV3A)		1
49	M-MS-0808-9402	FEL7V007014	BIRD LOGO L7VD(FEL7V007,REV3A)		1
50	C-BC-0302-0626	33L9VBCVS05	L9V BACK COVER ASSY		1
51	M-CV-0830-2592	EAL9V003011	LCD COVER L9V(EAL9V003,REV3A)		1
52	M-MS-0808-9253	FEL7V005011	LOGO PLATE ELLIPSE L7VC(FEL7V005,REV3A)		1
53	M-MS-0808-9411	FBL70008014	LOCK METAL L70B(FBL70008,REV3A) GP		1
54	M-CV-0830-2590	FBL9V001019	HINGE -L L9V(FBL9V001,REV3A)		1
55	M-BK-0805-0111	FBL9V002015	HNGE-BKT L9V(FBL9V002,REV3A)		1
56	M-CV-0830-2591	FBL9V003011	HINGE-R L9V(FBL9V003,REV3A)		1
57	M-SCW-0824-6895	MF40080IBJ1	SCREW F4.0*8-I(NI)		8
58	M-SCW-0824-6859	MM40060IL69	SCREW M4*6-I (BNI)(NYLOK))		6
59	E-00001775	AAM190EN129	LCD(TFT) 19" M190EN04 REV:V5		1
60	M-BK-0805-0079	FAL7V014017	PCB BKT L7VD(FAL7V014,REV3A)		1
61	M-MS-0808-9405	FAL7V015013	PCB SHIELDING L7VD(FAL7V015,REV3A)		1
62	HW-00001807	FBL9V009010	LCD BKT L-R L9VD-1(FBL9V009,REV3A)		2
63	HW-00001802	FBL9V010018	LCD PANEL LOCK METAL L9VD1(FBL9V010,R3A)		2

Item	ViewSonic P/N	Ref. P/N	Description	Location	Q'ty
64	M-SCW-0824-0726	MF30080BBJ5	SCREW F3.0*8L,B,NI		2
65	M-SCW-0824-6802	MM30040IBJ9	SCREW M3.0*4.0-I(NI) GP		14
66	M-SCW-0824-6800	MM30060IBJ8	SCREW M3.0*6.0-I(NI) GP		11
67	M-SCW-0824-6799	MM35080BBW2	SCREW M3.5*8-B (NI,WASHER)		1
68	M-MS-0808-8986	MBLI1004018	IO NUT L1I(MBLI1004,REV3A)		4
69	M-MS-0808-9247	EBL70023013	WIRE MOUNTS L70L-E(EBL70023,REV3A) GP		1
70	#N/A	EBL7V030013	PCB SPACER L7VD(EBL7V030,REV3A)		1
71	PL-00001804	GAL70002015	RUBBER-HOLDER L70L(GAL70002,REV3B)		2
72	PL-00001806	GAL5T001016	RUBBER-HOLDER L5TL-E(GAL5T001,REV3B)		4
73	PL-00001805	GAL70005014	RUBBER-BKT(T) L70L-T(GAL70005,REV3A)		2
74	#N/A	MBL9V001019	IO NUT L9VDA-5(MBL9V001,REV3A)M3*15*6		2
75	#N/A	GAL7E002013	LCD RUBBER L7E(GAL7E002,REV3B)		1
76	C-BS-0303-0553	24L9VSAVS02	L9V STAND ASSY		1
77	#N/A	34L9VSBVS08	L9V STAND BKT ASSY		1
78	C-BS-0303-0553	EAL9V004017	STAND BASE L9V(EAL9V004,REV3A)		1
79	M-MS-0808-9811	GAL5M002011	RUBBER FOOT L5M(GAL5M002,REV3B)		4
80	M-CV-0830-2589	EAL9V005013	STAND BKT COVER L9V(EAL9V005,REV3A)		1
81	M-SCW-0824-0813	MF30060BBJ6	SCREW F3.0*6-B(NI)		9
82	M-MS-0808-9812	EBL9V001019	STAND COVER F L9V(EBL9V001,REV3A)		1
83	M-MS-0808-9404	EBL7V029015	WIRE CLAMP L7VD(EBL7V029,REV3A)		2
84	M-SCW-0824-6894	MF30060BJ28	SCREW F3.0*6-B(BNI)		4
85	#N/A	25L9VCSVS50	L9VDA-5 CHASSIS ASSY(VX924)		1
86	CB-00002525	DD0L9VLC015	CABLE MB-LCD(30P,140MM)L9V-5 GP		1
87	M-MS-0808-9398	DDL7VDTH009	CABLE ASSY L7VD BUTTON-MB(8P/10P,REV1A)		1
88	C-00001778	EBL9V002015	STAND COVER R L9V(EBL9V002,REV3A)		1
89	M-CV-0830-2593	EBL9V003011	I/O COVER L9V(EBL9V003,REV3A)		1
90	M-SCW-0824-6859	MM40060IL69	SCREW M4*6-I (BNI)(NYLOK)		4
91	M-SCW-0824-0870	MS40070B808	SCREW M4*7B (BMC)NYLOK		4
92	M-MS-0808-9815	GAL9V002014	RUBBER PLUG VESA L9V(GAL9V002,REV3A)		4
93	CB-00002522	DD0L9V0B000	CABLE MB-OVER DRIVER(30P,50MM)L9V-5 GP		1
94	#N/A	26L9VPKVSP1	L9VDA-5 PACKING ASSY(AU,VX924)US		1
95	M-MS-0808-9399	DDL7VDP005	CABLE ASSY L7VD MB-VGA (15/15P,REV1A)		1
96	A-PC-0106-0224	DM333181G97	POWER CORD 3P 1.8M(USA)V04VS35001218000		1
97	M-MS-0808-9817	HAL9V002014	EPE BAG L9VD(HAL9V002,REV3A)		1
98	P-FM-0602-0896	HBL9V001019	END CAP-L L9V(HBL9V001,REV3A)		1
99	P-FM-0602-0897	HBL9V002015	END CAP-R L9V(HBL9V002,REV3A)		1
100	M-LB-0813-0747	HCL7V004013	CORE LABEL(HCL7V004,REV3A)		1
101	#N/A	HCL9V006011	ID LABEL VX924 L9VDA-5(HCL9V006,REV3A)		1
102	M-LB-0813-0745	HCL7V002011	SERIAL LEBAL L7V(HCL7V002,REV3A)		1
103	M-LB-0813-1042	HCL7V019011	CARTON LABEL L7VC(HCL7V019,REV3B)		1
104	P-00002521	HFL9V007011	CARTON VX924 L9VDA-5(HFL9V007,REV3A)		1
105	#N/A	HGL9V011019	CD+QSG VX924 L9VDA-5 USA(HGL9V011,REV3A)		1
106	#N/A	JXLM5003011	HANDLE LM5S(JXLM5003,REV 3B) GP		1
107	M-MS-0808-9682	JXL9V001010	LCD FILM L9V(JXL9V001,REV3A)		1
108	M-LB-0813-1043	HCL70021011	HI-POT LABEL L70L(HCL70021,REV3A)		1
109	#N/A	HFL9V002019	SPACE PLATE L9V(HFL9V002,REV3A)		0.05
110	M-00002524	HCL9V007018	4MS STICKER VX924 L9VD(HCL9V007,REV3A)		1

8. Exploded Diagram and Spare Parts List

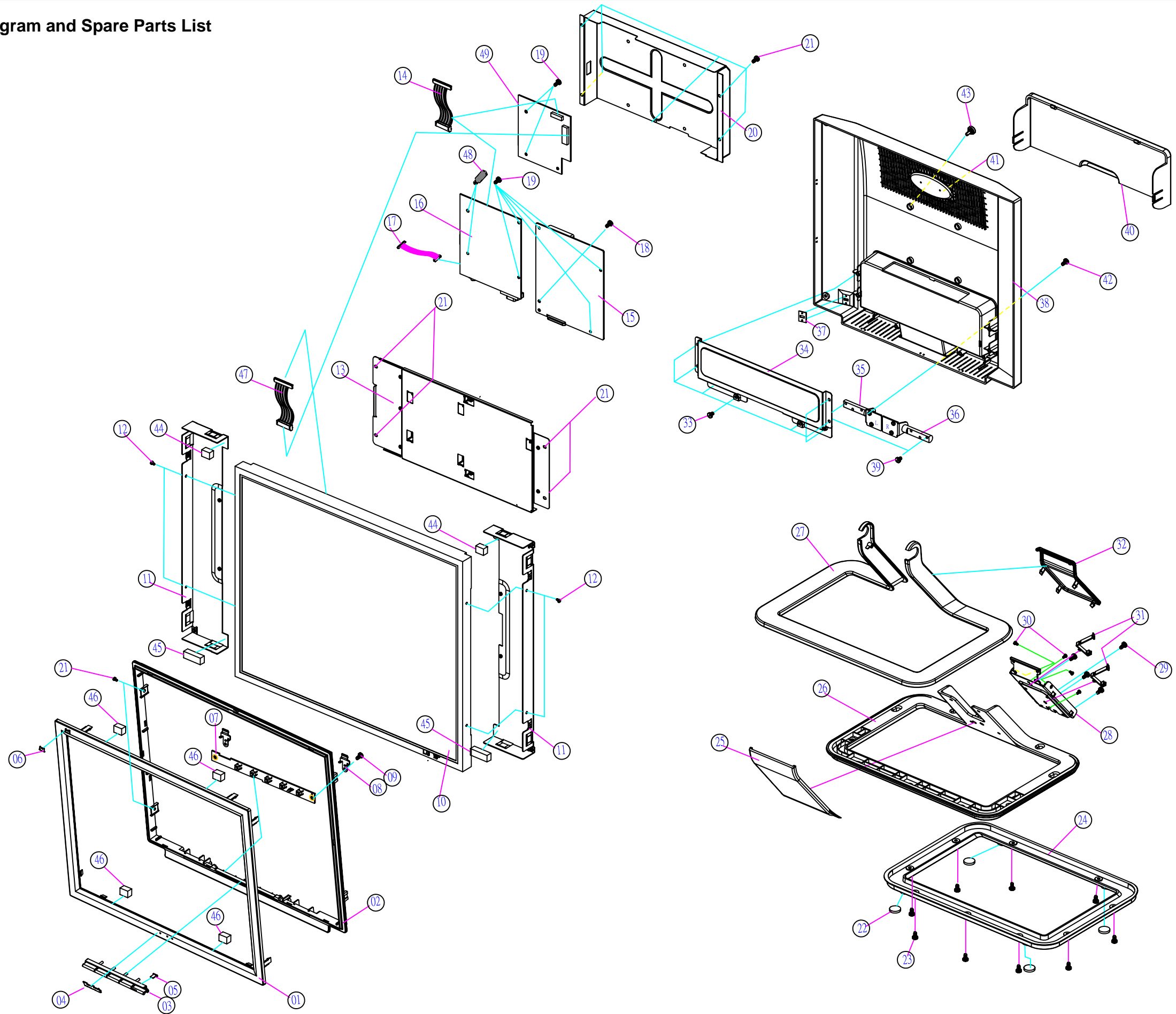

EXPLODED PARTS LIST (VX924-1)

ViewSonic Model Number: VS10162-3W

Rev: 1a

Item	ViewSonic P/N	Ref. P/N	Description	Q'ty
1	C-00000987	EAL9V001018	BEZEL L9V(EAL9V001,REV3A)	1
2	C-FP-0301-1047	EAL9V002014	MIDDLE BEZEL L9V(EAL9V002,REV3A)	1
3	PL-BT-0706-0165	EBL7V027012	CONTROL BUTTON L7VD(EBL7V027,REV3A)	1
4	M-MS-0808-9243	FEL7V003019	LOGO FRONT-VSC-38CM L7VC(FEL7V003,REV3A)	1
5	M-MS-0808-9401	EBL7V028019	LENS L7VD(EBL7V028,REV3A)	1
6	M-MS-0808-9402	FEL7V007014	BIRD LOGO L7VD(FEL7V007,REV3A)	1
7	B-CB-0206-0188	23L7VBB0034	L7VD BUTTON/B ASSY	1
8	HW-00001802	FBL9V010018	LCD PANEL LOCK METAL L9V	2
9	M-SCW-0824-0726	MF30080BBJ5	SCREW F3.0*8L,B,NI	2
10	E-00001775	AAM190EN129	LCD(TFT) 19" M190EN04 REV:V5	1
11	HW-00001807	FBL9V009010	LCD BKT L9V(FBL9V004,REV3A)	2
12	M-SCW-0824-6802	MM30040IBJ9	SCREW M3.0*4.0-I(NI) GP	4
13	M-BK-0805-0079	FAL7V014017	PCB BKT L7VD(FAL7V014,REV3A)	1
14	CB-00002522	DD0L9V0B000	CABLE MB-OVER DRIVER(30P,50MM) L9V-5 GP	1
15	B-PS-0204-0076	AS02B012D24	ADD/INV,FSP035-1PI01,90~264V REV1A	1
16	B-00002519	29L9IMB00E5	L9I M/B ASSY (FOR L9VDA-5 REALTEK2523)AU	1
17	M-MS-0808-9398	DDL7VDTH009	CABLE ASSY L7VD BUTTON-MB (8P-10P)	1
18	M-SCW-0824-6799	MM35080BBW2	SCREW M3.5*8-B (NI,WASHER)	1
19	M-SCW-0824-6800	MM30060IBJ8	SCREW M3.0*6.0-I(NI)	7
20	M-MS-0808-9405	FAL7V015013	PCB SHIELDING L7VD(FAL7V015,REV3A)	1
21	HW-00000989	MM30040IBJ8	SCREW M3.0*4.0-I(NI)	10
22	M-MS-0808-9811	GAL5M002011	RUBBER FOOT L5M(GAL5M002,REV3B)	4
23	M-SCW-0824-0813	MF30060BBJ6	SCREW F3.0*6-B(NI)	1
24	M-CV-0830-2589	EAL9V005013	STAND BKT COVER L9V(EAL9V005,REV3A)	1
25	M-MS-0808-9812	EBL9V001019	STAND COVER F L9V(EBL9V001,REV3A)	1
26	M-BK-0805-0110	FBL9V005014	STAND BKT L9V(FBL9V005,REV3A)	4
27	C-BS-0303-0553	EAL9V004017	STAND BASE L9V(EAL9V004,REV3A)	1
28	M-MS-0808-9813	FBL9V006011	STAND PLATE L9V(FBL9V006,REV3A)	1
29	M-SCW-0824-6859	MM40060IL69	SCREW M4*6-I (BNI)(NYLOK))	4
30	M-SCW-0824-6894	MF30060BJ28	SCREW F3.0*6-B(BNI)	4
31	M-MS-0808-9404	EBL7V029015	WIRE CLAMP L7VD(EBL7V029,REV3A)	2
32	C-00001778	EBL9V002015	STAND COVER R L9V(EBL9V002,REV3A)	1
33	M-SCW-0824-6895	MF40080IBJ1	SCREW F4.0*8-I(NI)	8
34	M-BK-0805-0111	FBL9V002015	HNGE-BKT L9V(FBL9V002,REV3A)	1
35	M-CV-0830-2590	FBL9V001019	HNGE-L L9V(FBL9V001,REV3A)	1
36	M-CV-0830-2591	FBL9V003011	HNGE-R L9V(FBL9V003,REV3A)	1
37	M-MS-0808-9411	FBL70008014	LOCK METAL L70B(FBL70008,REV3A)	1
38	M-CV-0830-2592	EAL9V003011	LCD COVER L9V(EAL9V003,REV3A)	1
39	M-SCW-0824-6859	MM40060IL69	SCREW M4.0x6 (BNI)NYLOCK	6
40	M-CV-0830-2593	EBL9V003011	I/O COVER L9V(EBL9V003,REV3A)	1
41	M-MS-0808-9253	FEL7V005011	LOGO PLATE	1
42	M-SCW-0824-0870	MS40070B808	SCREW M4.0x7 (BMC)NYLOCK	4
43	M-MS-0808-9815	GAL9V002014	RUBBER PLUG VESA L9V	4
44	PL-00001804	GAL70002015	RUBBER HOLDER	2
45	PL-00001805	GAL70005014	RUBBER BKT	2
46	PL-00001806	GAL5T001016	RUBBER HOLDER	4
47	CB-00002525	DD0L9VLC015	CABLE MB-LCD(30P, 140MM)	1
48	N/A	MBL9V001019	IO NUT L9VDA-5	2
49	B-00002520	22L9V0B0005	L9V OVER DRIVER/B ASS'Y	1

Packing for shipping

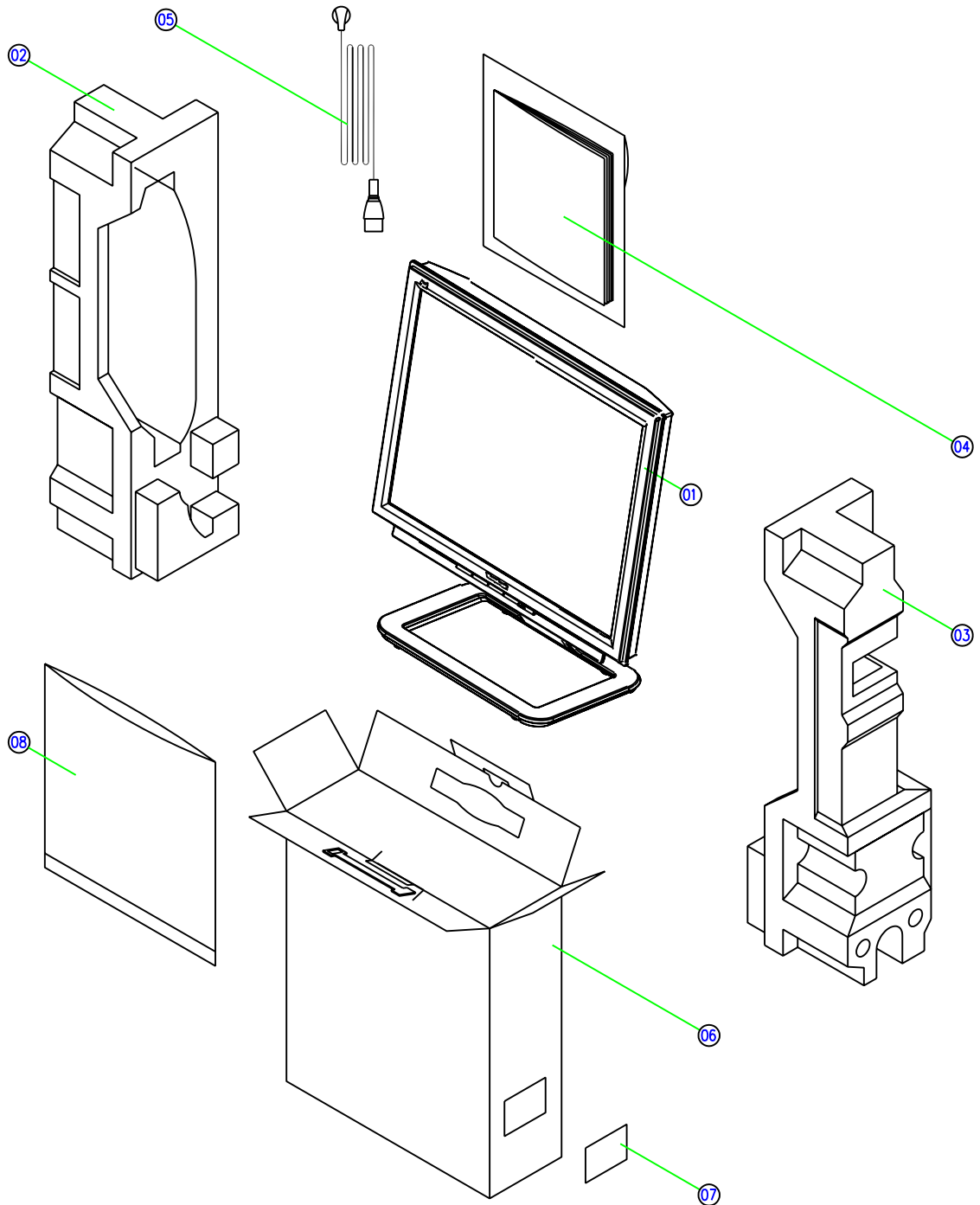

PACKING PART LIST (VX924-1)

ViewSonic Model Number: VS10162-3W

Rev: 1a

Item	ViewSonic P/N	Ref. P/N	Location	Q'ty
1	VX924	1L9VDZAVS41	VX924 unit	1
2	P-FM-0602-0896	HBL9V001019	END CAP(L)	1
3	P-FM-0602-0897	HBL9V002015	END CAP(R)	1
4	DC-00002523	HGL9V0011019	User manual & CD	1
5	A-PC-0106-0224	DM333181G97	Power cord 3P 1.8M	1
6	P-00002521	HFL9V007011	Carton	1
7	M-LB-0813-1042	HCL7V019011	Carton label	1
8	M-MS-0808-9817	HAL9V002014	EPE bag	1

Packing procedure

1. Apply protective film to the display surface.



2. Put the monitor in EPE bag and seal the bag with tape.



3. Fit the cushions onto the monitor.



- Put the monitor into the carton and put all the accessories into the carton.
Then close the carton.

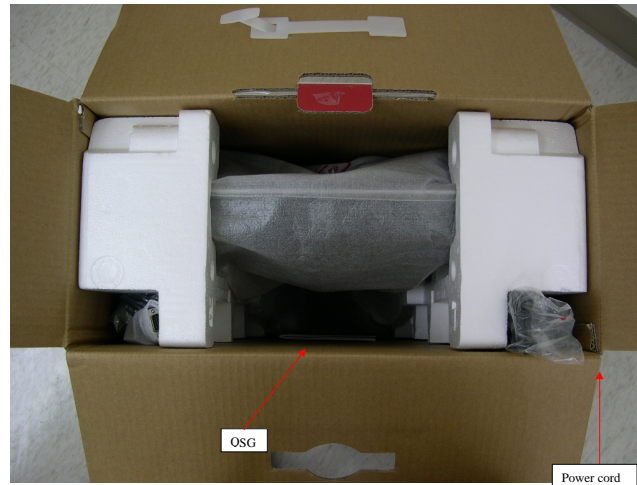

Disassembling the monitor

- Turn the monitor to face the back and remove the I/O cover.



- Remove the stand back cover.



3. Remove the four black hinge screws and separate the stand and head pieces.

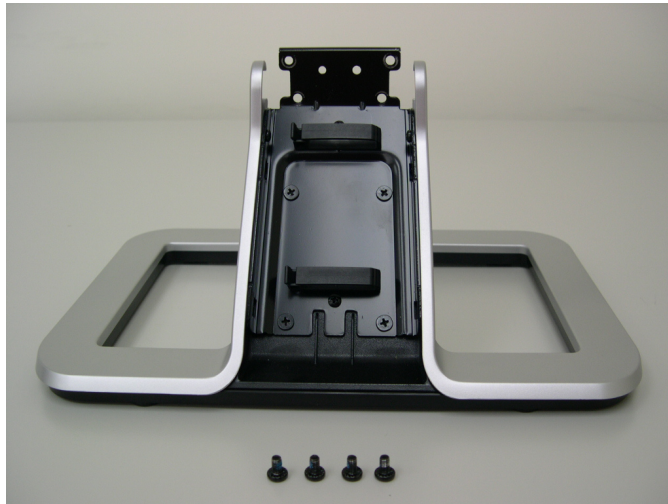

4. Place the monitor face-down on a soft, flat, stable surface.



5. Separate the back cover and the front bezel.

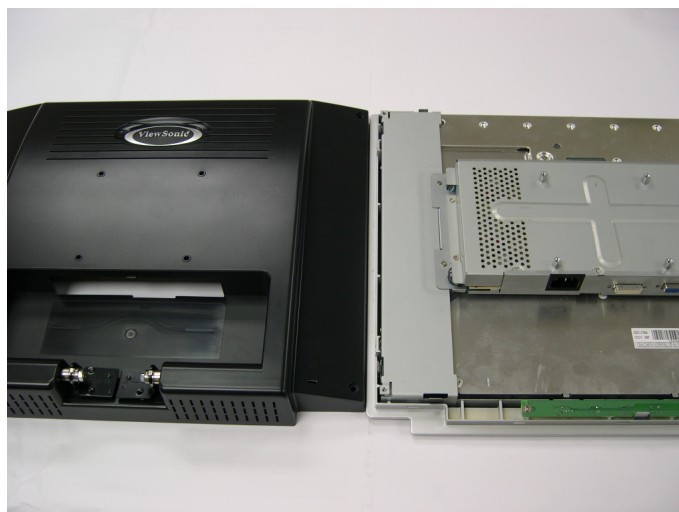

6. Remove the screws that fix the button board (B/B) and pull the cable out from the connector on the main board (M/B).



7. Remove the B/B.

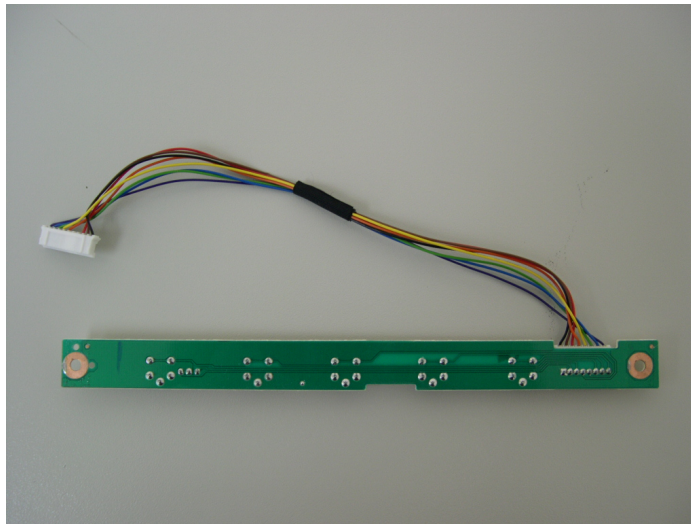

8. Remove the screws on the PCB shield; remove the PCB shield.

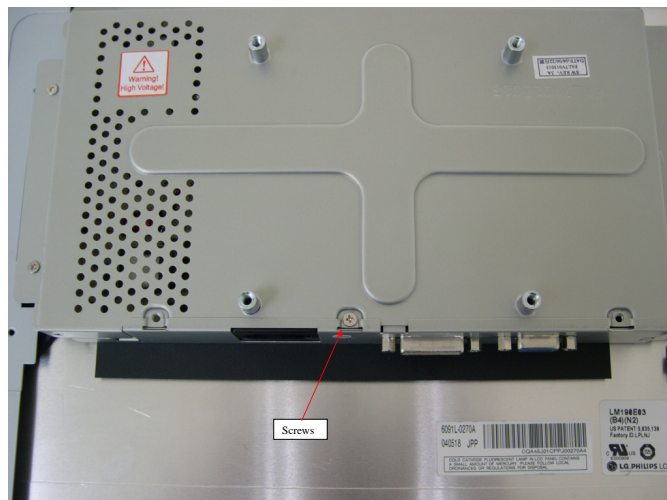

9. Remove the MB-LCD connector and loosen the four screws on the PCB holder.

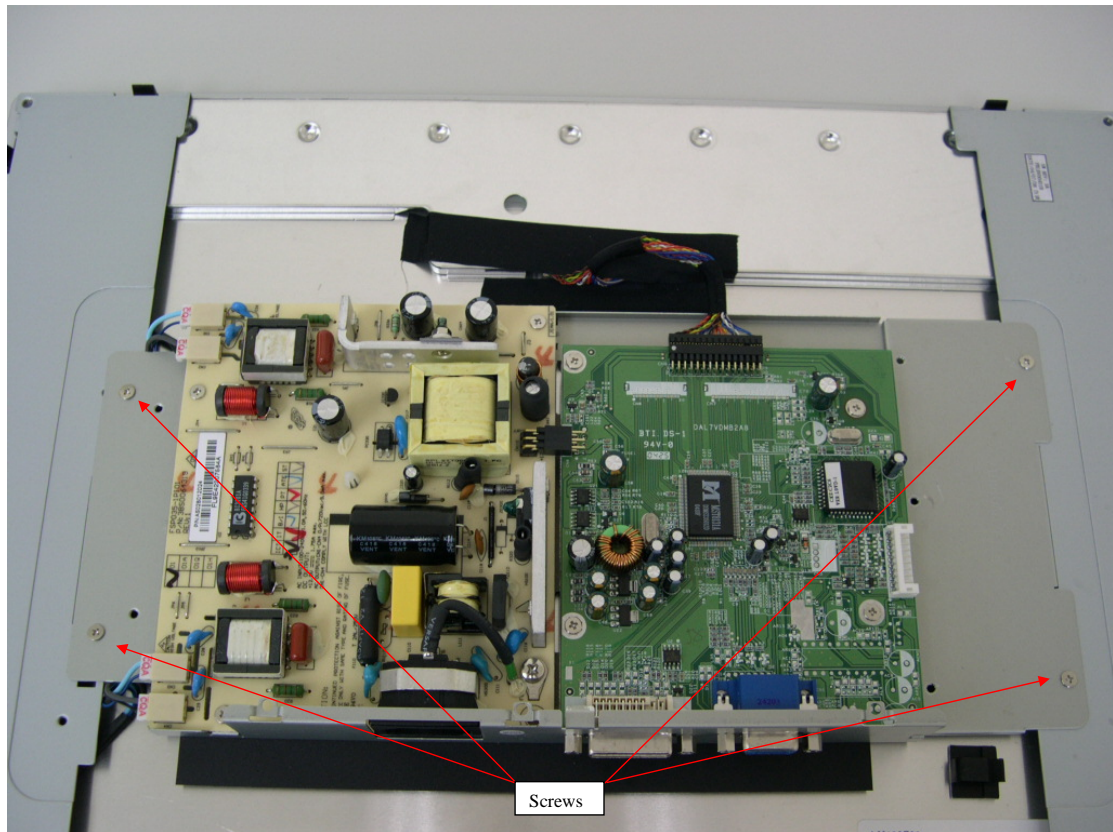

10. Separate the PCB holder from the panel.

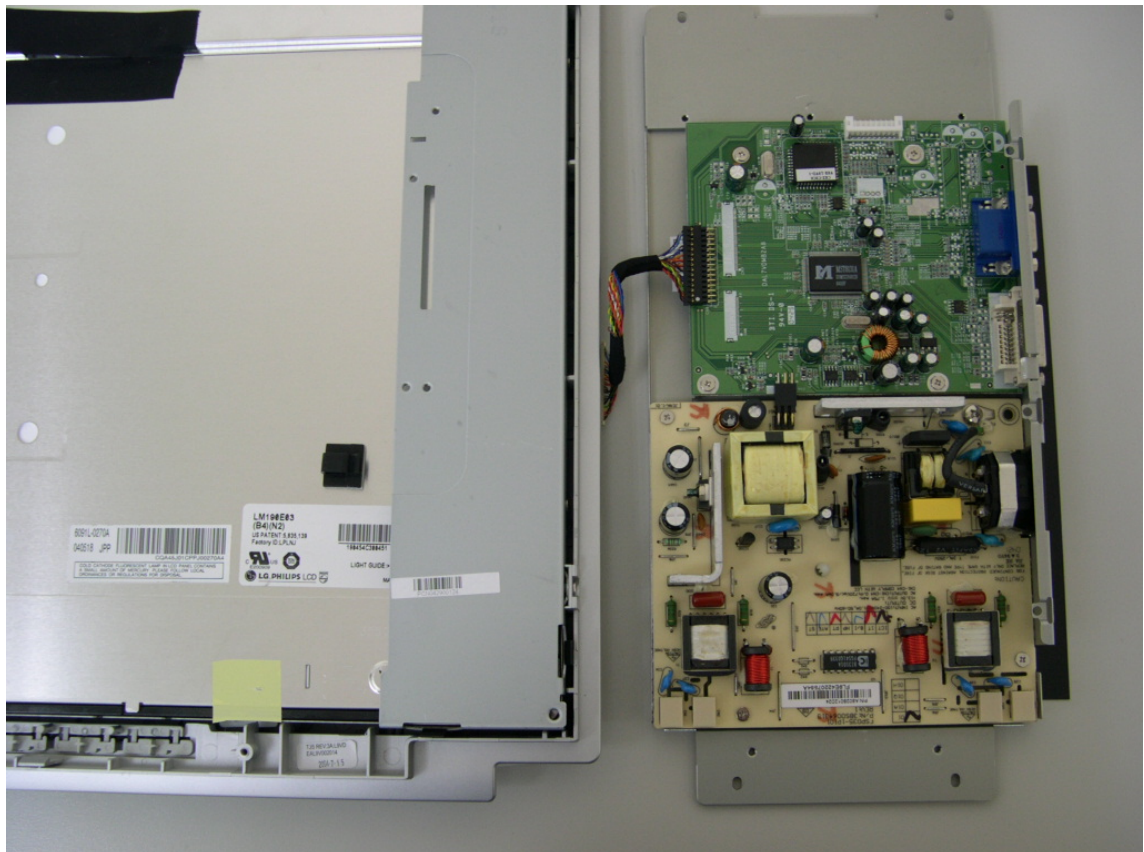

11. Loosen the four screws on the sides of the panel.



12. Remove the front bezel and panel.



13. Remove the four hexagon screws beside the DVI & D-SUB connectors.



14. Remove the screws that fix the power board and main board.

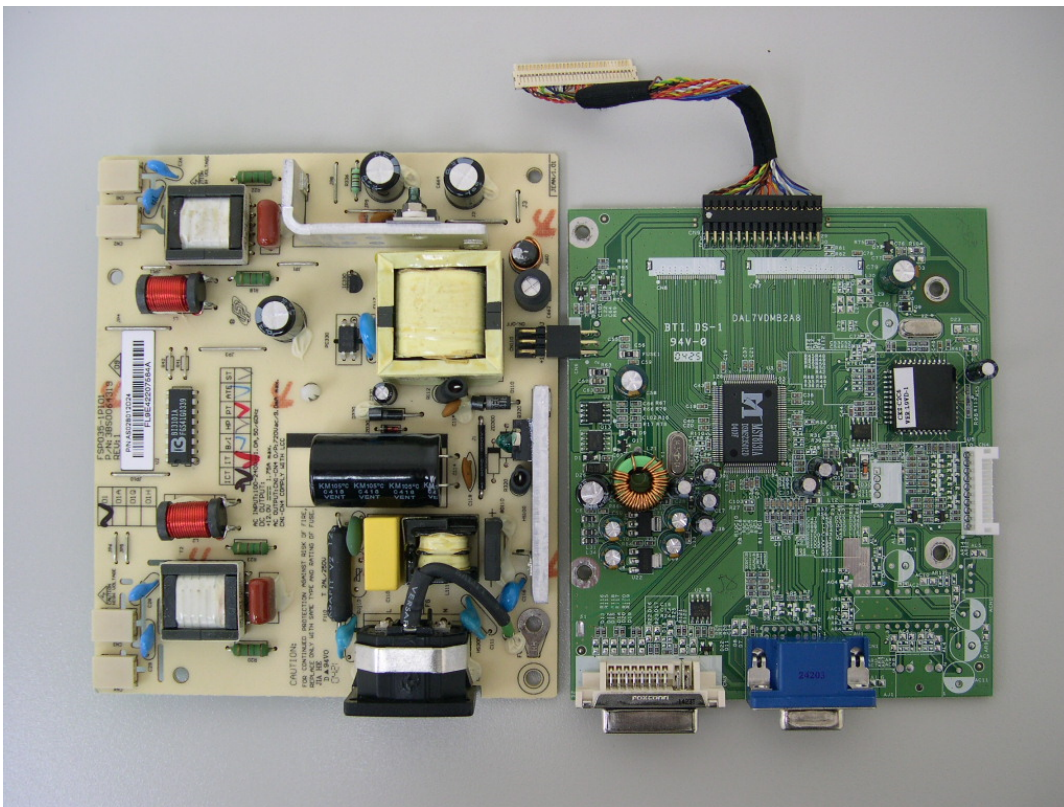

REALTEK RTD2523BLOCK DIAGRAM

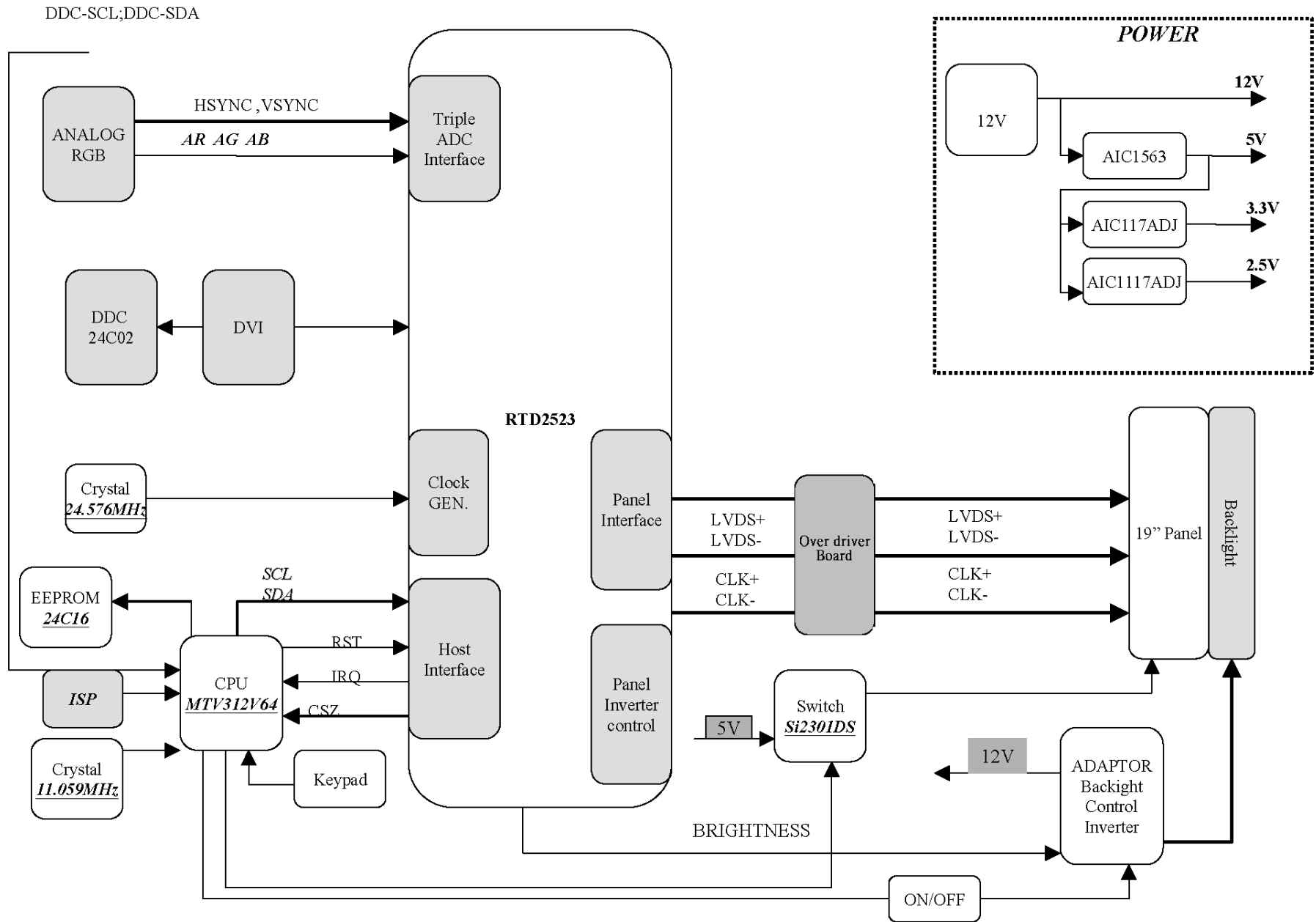

Over-driver block diagram

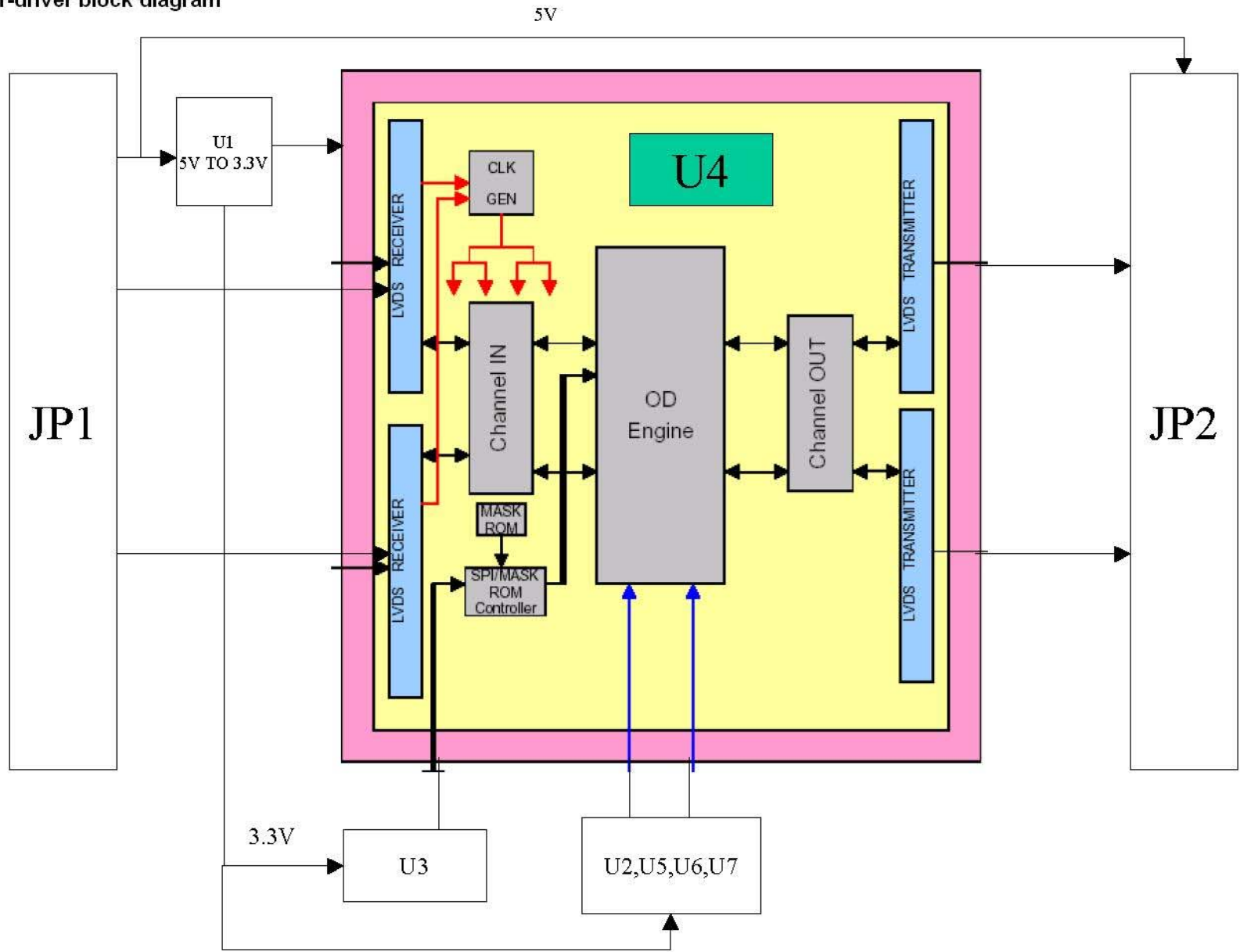

10. Schematic Diagrams

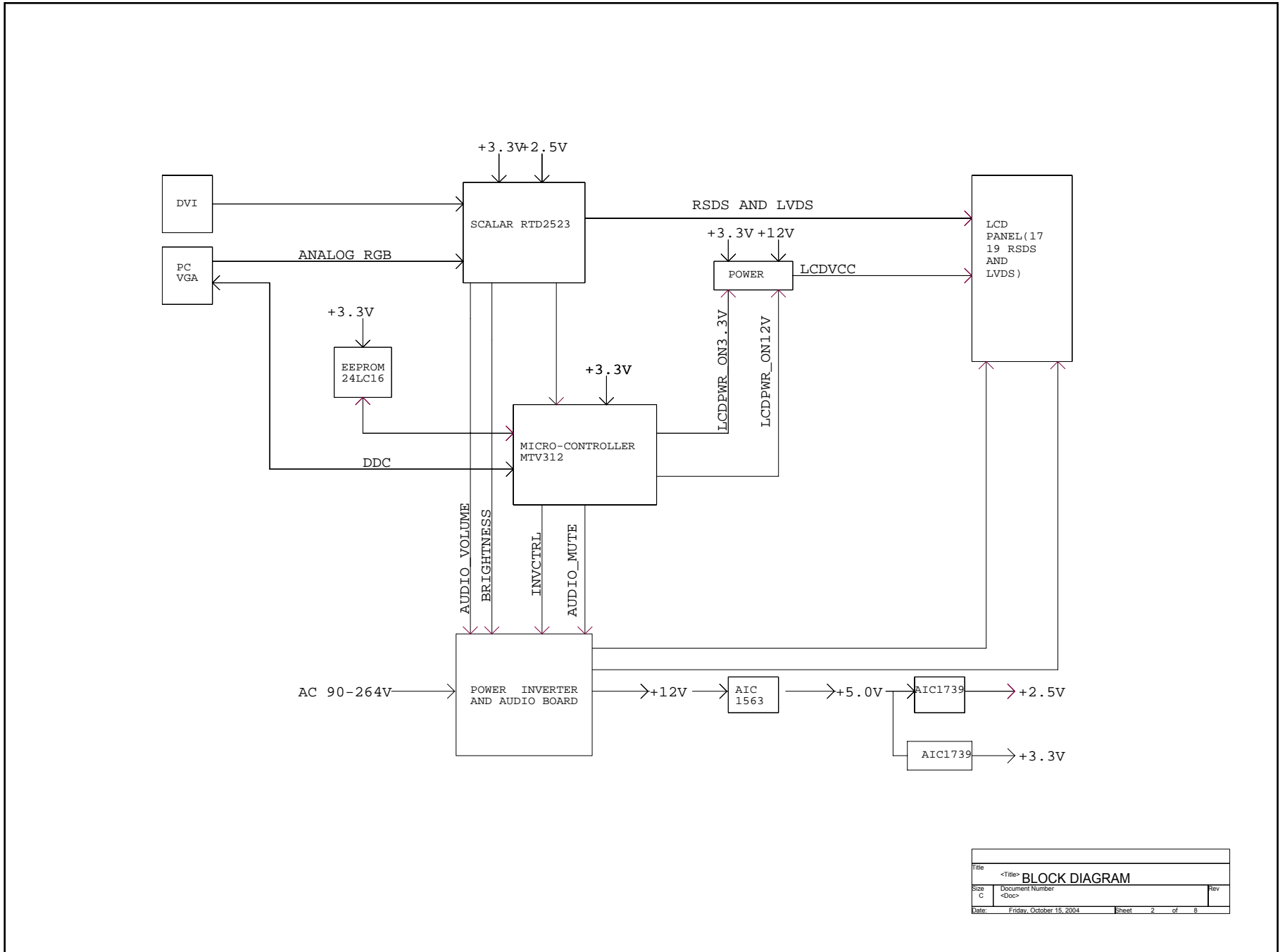

Title		
<Title> BLOCK DIAGRAM		
Size	Document Number	Rev
c	<Doc>	
Date: Friday, October 15, 2004		
Sheet 2 of 8		

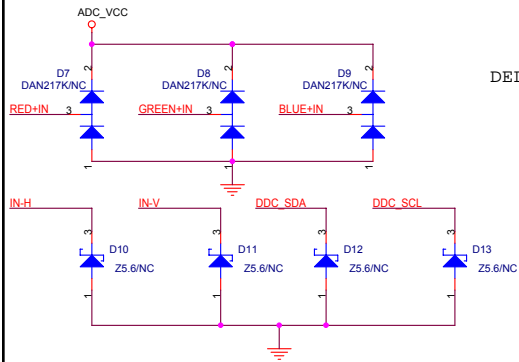
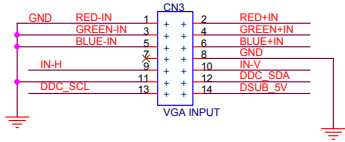
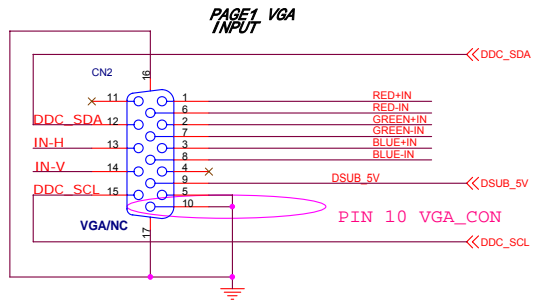

DEL D29 2004/6/17

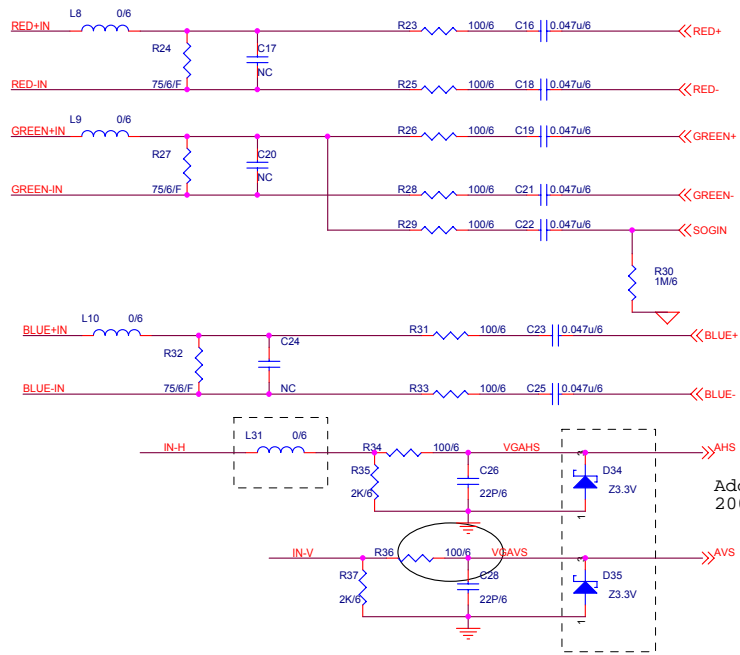

DEL L11, C32, U6, R51, R52 2004/6/17

Add D34, D35, L31
2004/6/17

Add R156~R162 damping RES 2004/4/16

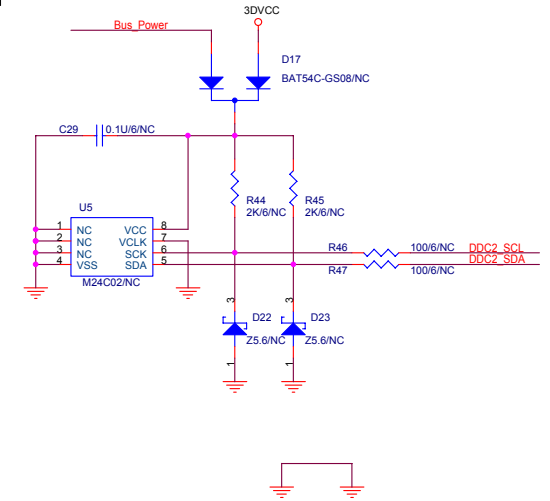
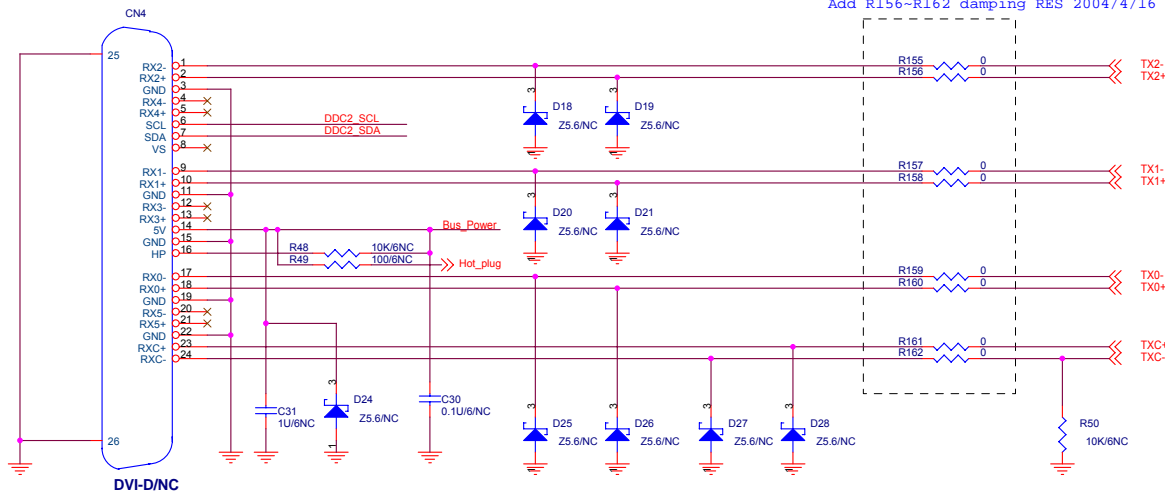

Title			
VGA AND DVI INPUT			
Size	Document Number	DISPLAY	Rev B
Date:	Friday, October 15, 2004	Sheet	3 of 8

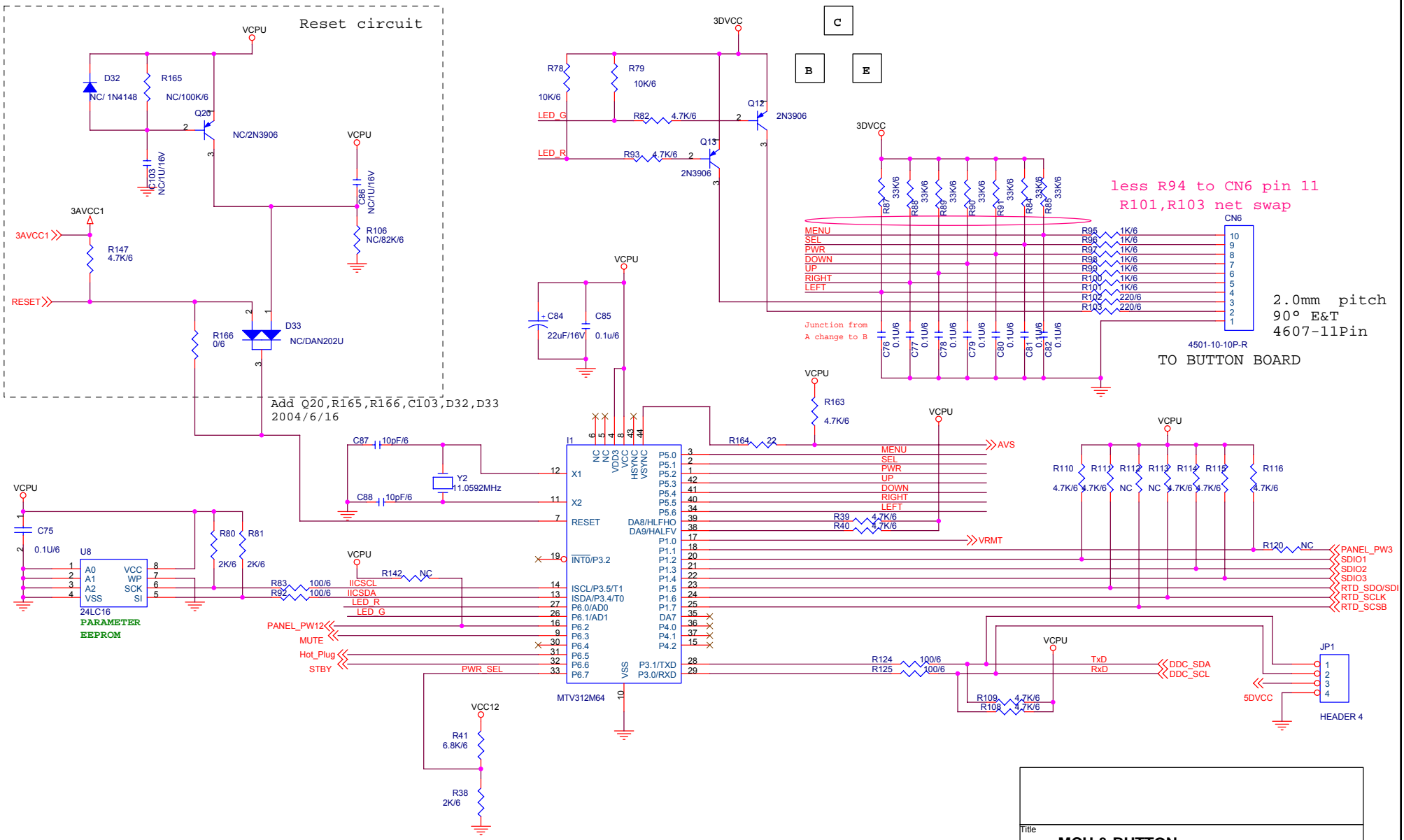

Title		
MCU & BUTTON		
Size	Document Number	Rev
	DISPLAY	A
Date:	Friday, October 15, 2004	Sheet 5 of 8

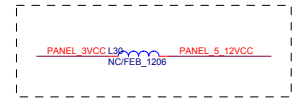
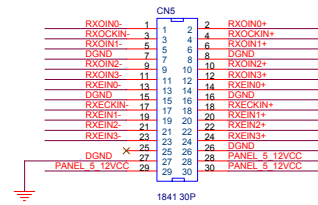
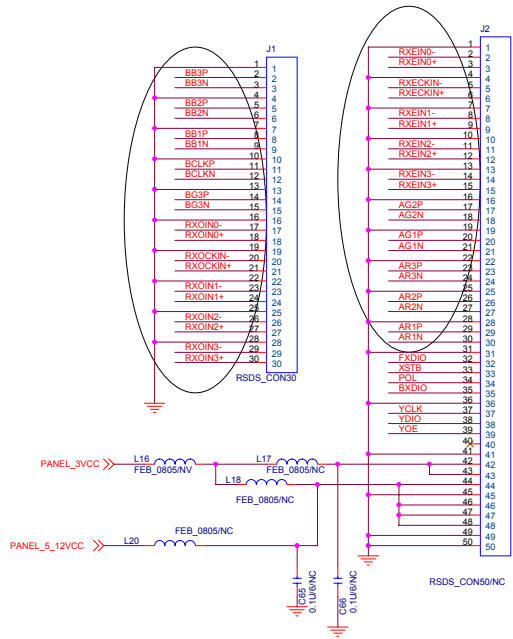
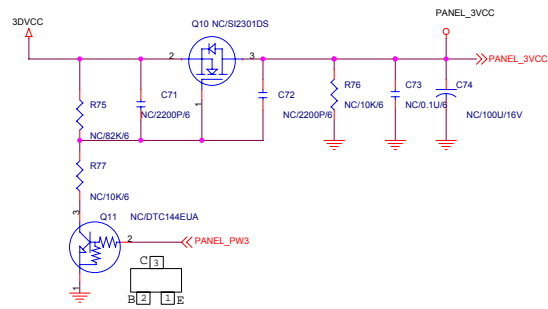
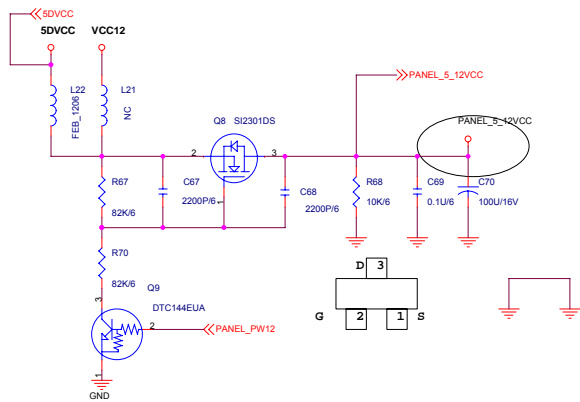

If panel is 3.3V LVDS IP, L30 must add the part 2004/4/14

File	<Title> PANEL INTERFACE	Rev
Size	Document Number	
C	<Doc>	
Date:	Friday, October 15, 2004	Sheet 6 of 8

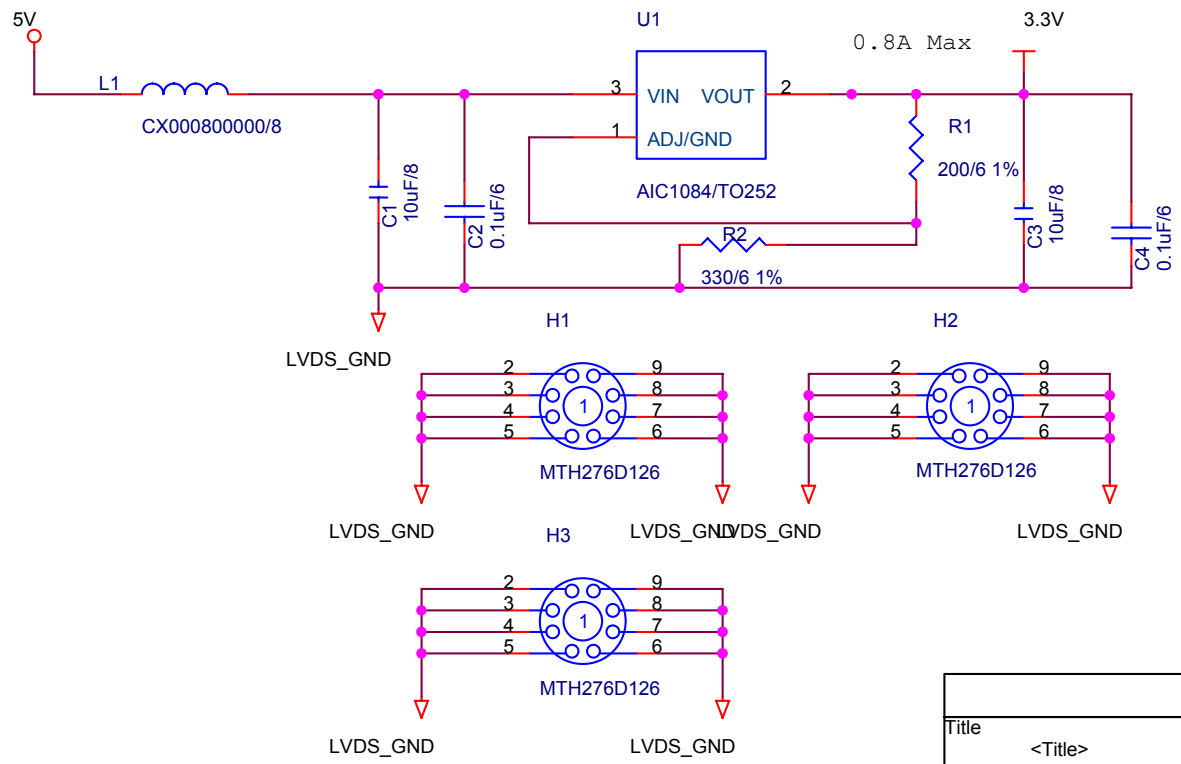

Title		
<Title>		
Size	Document Number	Rev
A	<Doc>	
Date:	Friday, February 25, 2005	Sheet of

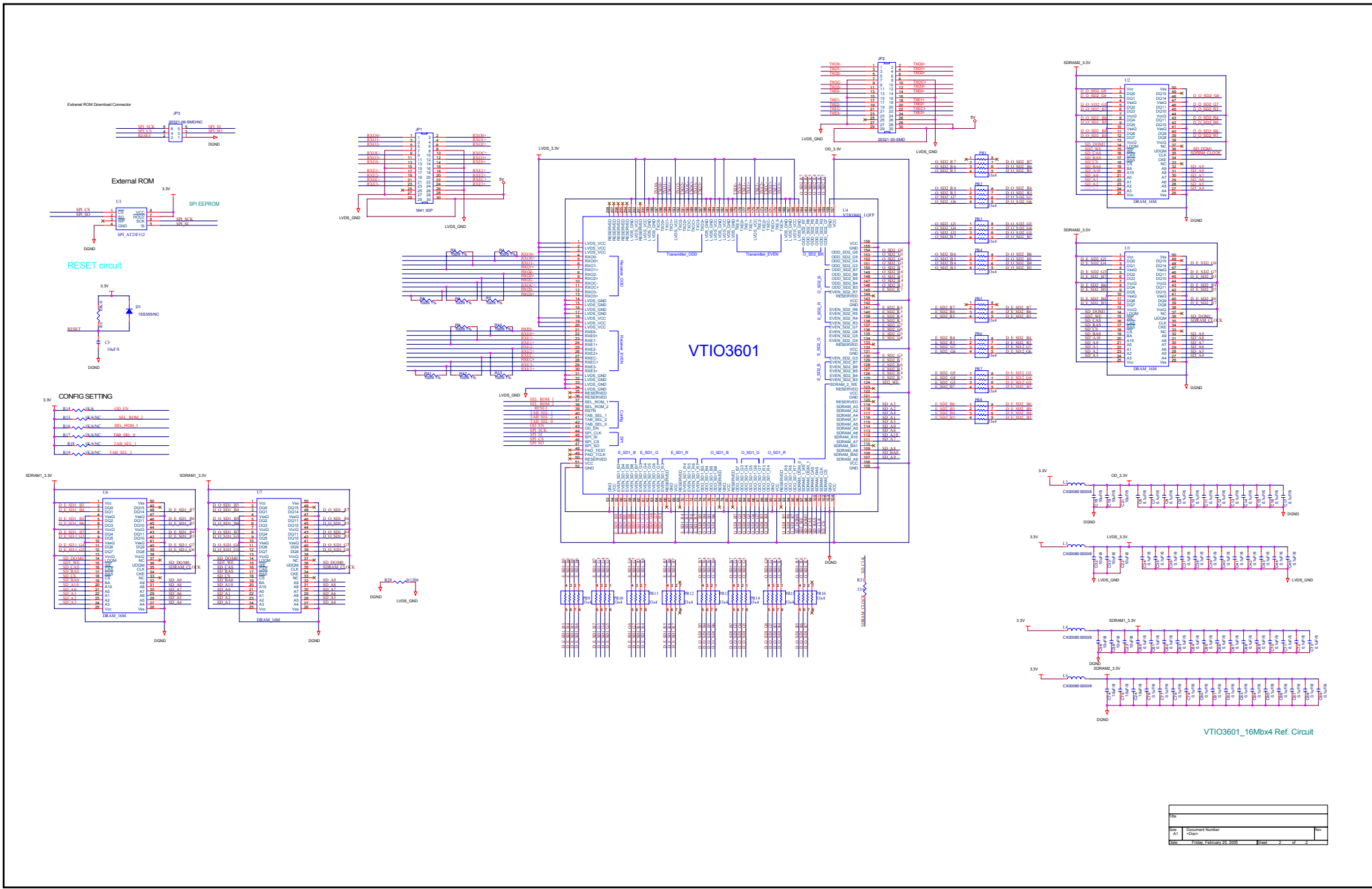

VTIO3601_16Mbit4 Ref. Circuit

Rev	
Doc	Document Number
Ver	1.00
Date	Friday, February 25, 2016
Sheet	2 of 2

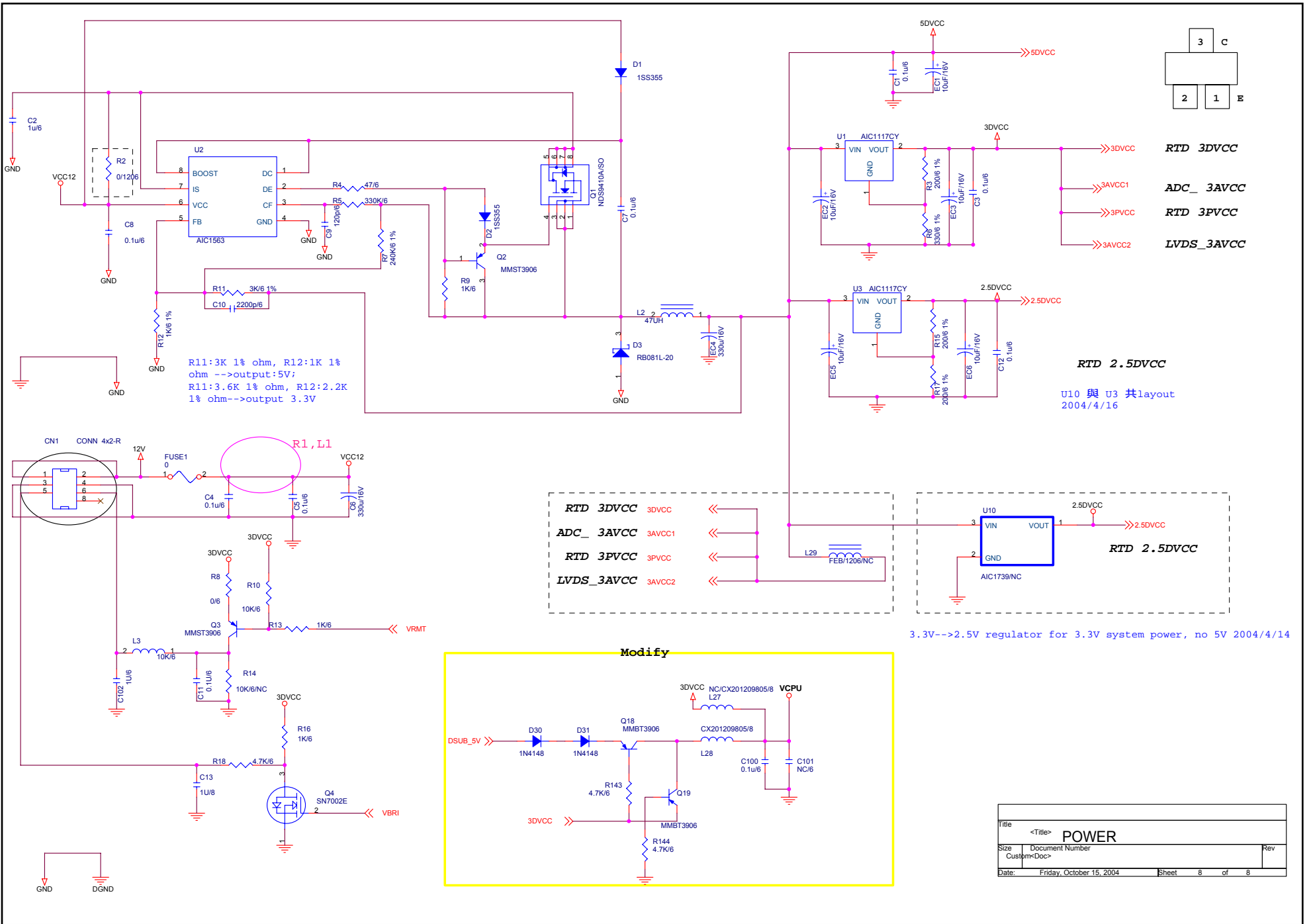

11. PCB Layout Diagrams

Control Board

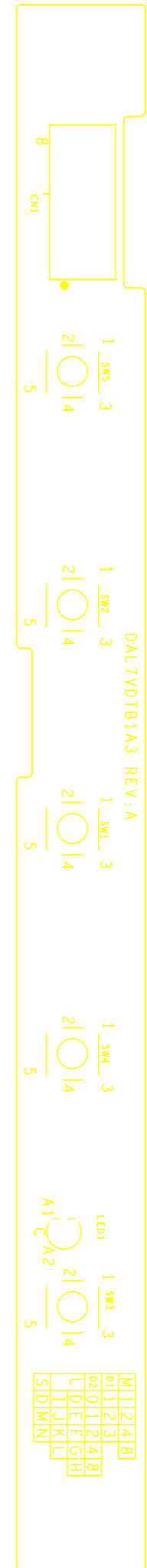
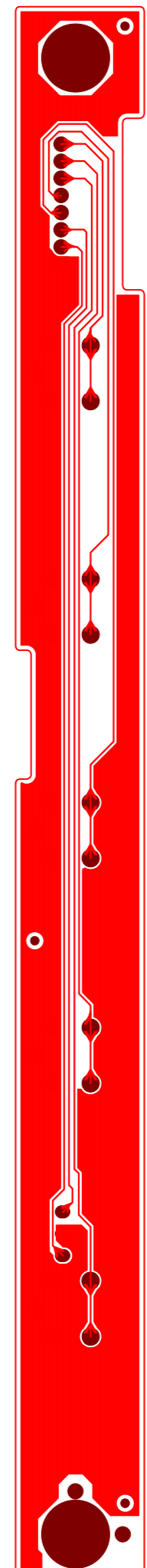
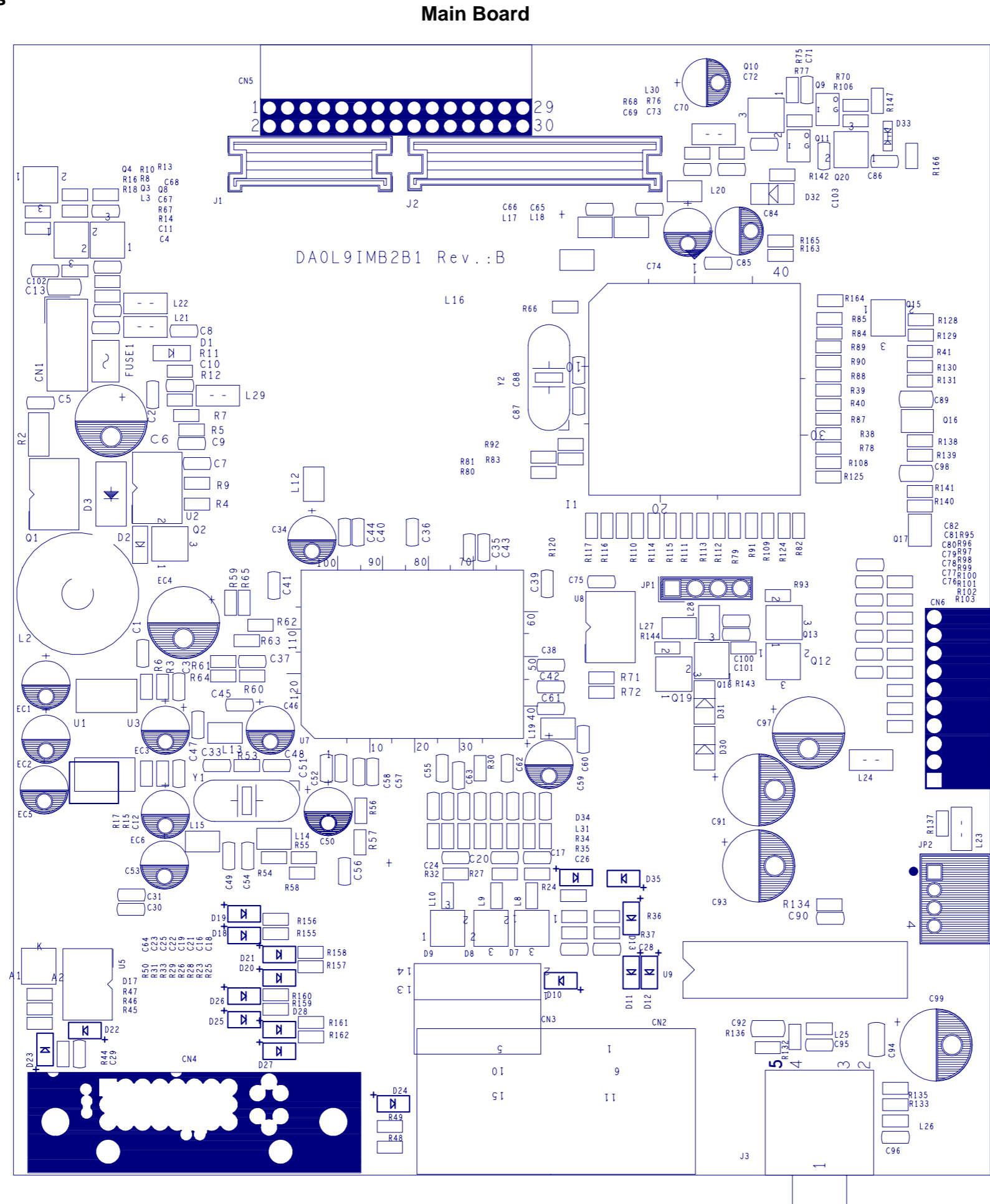

Reader's Response

Dear Readers:

Thank you in advance for your feedback on our Service Manual, which allows continuous improvement of our products. We would appreciate your completion of the Assessment Matrix below, for return to ViewSonic Corporation.

Assessment

A. What do you think about the content of this Service Manual?

<i>Unit</i>	<i>Excellent</i>	<i>Good</i>	<i>Fair</i>	<i>Bad</i>
1. Precautions and Safety Notices				
2. Specification				
3. Front Panel Function Control Description				
4. Circuit Description				
5. Adjustment Procedure				
6. Troubleshooting Flow Chart				
7. Recommended Spare Parts List				
8. Exploded Diagram and Exploded Parts List				
9. Block Diagram				
10. Schematic Diagrams				
11. PCB Layout Diagrams				

B. Are you satisfied with this Service Manual?

<i>Item</i>	<i>Excellent</i>	<i>Good</i>	<i>Fair</i>	<i>Bad</i>
1. Service Manual Content				
2. Service Manual Layout				
3. The form and listing				

C. Do you have any other opinions or suggestions regarding this service manual?

Reader's basic data:

Name:		Title:	
Company:			
Add.:			
Tel:		Fax:	
E-mail:			

After completing this form, please return it to ViewSonic Quality Assurance in the USA at facsimile 1-909-839-7943. You may also e-mail any suggestions to the Director, Quality Systems & Processes (marc.maupin@viewsonic.com)