

Service Manual

ViewSonic VG930m-3

VA930m-1

Model No. VS11369

19" Color TFT LCD Display

(VG930m-3_VA930m-1_SM Rev. 1a Oct. 2006)

ViewSonic 381 Brea Canyon Road, Walnut, California 91789 USA - (800) 888-8583

Copyright

Copyright © 2006 by ViewSonic Corporation. All rights reserved. No part of this publication may be reproduced, transmitted, transcribed, stored in a retrieval system, or translated into any language or computer language, in any form or by any means, electronic, mechanical, magnetic, optical, chemical, manual or otherwise, without the prior written permission of ViewSonic Corporation.

Disclaimer

ViewSonic makes no representations or warranties, either expressed or implied, with respect to the contents hereof and specifically disclaims any warranty of merchantability or fitness for any particular purpose. Further, ViewSonic reserves the right to revise this publication and to make changes from time to time in the contents hereof without obligation of ViewSonic to notify any person of such revision or changes.

Trademarks

Optiquest is a registered trademark of ViewSonic Corporation.

ViewSonic is a registered trademark of ViewSonic Corporation.

All other trademarks used within this document are the property of their respective owners.

Revision History

Revision	SM Editing Date	ECR Number	Description of Changes	Editor
1a	10/29/2006		Initial Release	Jamie Chang

TABLE OF CONTENTS

1. Precautions and Safety Notices	1
2. Specification	4
3. Front Panel Function Control Description	8
4. Circuit Description	14
5. Adjustment Procedure	21
6. Troubleshooting Flow Chart	53
7. Recommended Spare Parts List	61
8. Exploded Diagram and Exploded Parts List	66
9. Block Diagram	69
10. Schematic Diagrams	70
11. PCB Layout Diagrams	75

1. Precautions and Safety Notices

1. Please carefully read this manual before operating the device and keep it available for future reference.
2. To avoid the danger of the monitor falling and thereby possibly causing injury and/or serious damage to the monitor itself, do not place it on unstable cars or desks. Be careful to avoid placing any stress on the LCD screen during handling.
3. Do not place this monitor in areas that are wet or where water or other liquids may come in contact with it, such as bathrooms, kitchens, wet floors, near washing machines or by swimming pools.
4. Remove the power plug from the electrical socket before cleaning. No water-containing cleaning agent should be used to clean the screen, but only cleaning agents formulated specifically for cleaning LCD screens. Do not put any liquid cleaning agent directly on the screen, but put it on a soft cloth first and then gently apply the cloth to the screen.
5. In order to guarantee reliable operation and adequate heat dissipation, do not cover or block vent holes on the monitor. Do not put the monitor close to heat sources. Do not place the monitor on furniture such as a bookshelf, unless sufficient ventilation is available.
6. A 3-pin grounding plug is provided for this monitor. In order to guarantee normal operation and safety of this unit, this plug should be used with a matching grounded power socket.
7. Please follow all warnings and instructions that accompany the monitor.
8. Please pay special attention to power supply overloads, as electrical shock or fire may occur.
9. Do not place anything on the power cord. Do not hang the power cord over an area where people or objects may pass.
10. In case the monitor is not be used for an extended period, turn off power to avoid the possibility of short circuits caused by lightning.
11. In order to avoid electrical shock or fire risks, do not insert any object through any openings in the monitor's enclosure. Do not allow any liquid to come in contact with the monitor.
12. In case of any abnormal noise or odor caused by incorrect operation, turn off power immediately and contact a professional technician. Do not attempt to repair this monitor by yourself, as electrical shock may occur when opening the back cover or accessing internal components.
13. If any of the following conditions occurs, turn off power and contact a repair service provider:
 - 1) the power cord is damaged or worn;
 - 2) liquid has gotten into the monitor, or the monitor has experienced immersion or wetting;
 - 3) the monitor has fallen;
 - 4) the monitor's performance shows obvious changes;
 - 5) the monitor fails to work normally when correct procedures are followed. In that case, please make any adjustments in accordance with instructions supplied with the monitor; do not attempt any changes to established procedures, as further damage may occur, making successful repair of the monitor more difficult.
14. In case parts need to be replaced, you must use identical parts or those supplied by our certified manufacturers. Any other parts used without our authorization may result in electrical shock or fire risk.

Handing and Placing methods

Correct methods	Incorrect methods
<p>Only touch the metal frame of the LCD panel or the front cover of the monitor, DO not touch the surface of the POL</p> 	<p>Surface of the LCD panel is pressed by fingers and that may cause "mura"</p> 
<p>Take out the monitor with cushions</p>  	<p>Taking out the monitor by grasping the LCD panel, that May cause "mura"</p>  

Correct methods

Place the monitor on a clean and soft foam pad



Incorrect methods

Placing the monitor on a foreign objects, that could scratch The surface of the "Panel" or cause "mura"



The panel is placed facedown the lap,that may cause "mura"

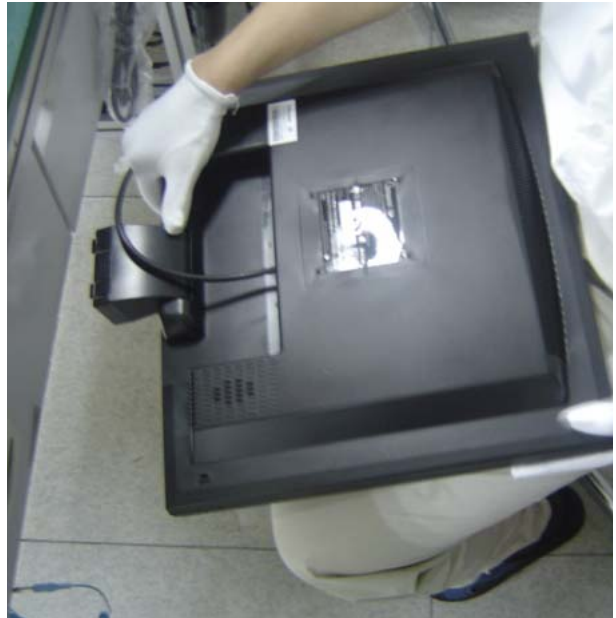

2. Specification

Introduction

The purpose of this document is to define design and performance requirements for **MR19V** (using **RTD2523B** and **HSD 19"** panel), the **19.X**-inch TFT-LCD monitor.

Features

- **19"** SXGA TFT LCD panel
- TN (Twist Nematic) Mode
- Analog input up to 1280X1024@75Hz
- 4 dual CCFTs (Cold Cathode Fluorescent Tube)
- Supported to 75Hz refresh rate
- Supported to 16.2M colors display
- Supported VESA-DDC2B plug & play function
- Supported VESA-DPMS power management function
- LVDS (Low Voltage Differential Signaling) interface (2 pixels/clock)

1	LCD PANEL (1 st source)	Panel: Size Pixel Arrange Glass Treatment Contrast Ratio Viewing Angle Colors Luminance Response Time Backlight Backlight Life Mercury	CR >= 10 CR >= 5 On/Off	HSD190ME13-A16 19" Color a-Si TFT Active Matrix 1280x1024 LCD 0.294 mm x 0.294 mm Anti-Glare, Hard coating (3H) 700 :1 150/135 (degrees; typ) 160/155 (degrees; typ) 16.2 million colors (6+2 bit panel) 300 cd/m2 8 ms 4 CCFL 50000 Hrs (Min) 3 mg per lamp
2	LCD PANEL (2 nd source)	Panel: Size Pixel Arrange Glass Treatment Contrast Ratio Viewing Angle Colors Luminance Response Time Backlight Backlight Life Mercury	CR >= 10 CR >= 5 On/Off	HSD 190ME13- A10 19" Color a-Si TFT Active Matrix 1280x1024 LCD 0.294 mm x 0.294 mm Anti-Glare, Hard coating (3H) 700 :1 150/135 (degrees; typ) N/A (degrees; typ) 16.2 million colors (6+2 bit panel) 300 cd/m2 8 ms 4 CCFL 40000 Hrs (Min) 3 mg per lamp

	LCD PANEL (3 rd source)	Panel: Size Pixel Arrange Glass Treatment Contrast Ratio Viewing Angle Colors Luminance Response Time Backlight Backlight Life Mercury	CR >= 10 CR >= 5 On/Off	HSD 190ME13-D10 19" Color a-Si TFT Active Matrix 1280x1024 LCD 0.294 mm x 0.294 mm Anti-Glare, Hard coating (3H) 700 :1 150/140 (degrees; typ) N/A (degrees; typ) 16.2 million colors (6+2 bit panel) 300 cd/m2 8 ms 4 CCFL 50000 Hrs (Max)/ 40000Hrs @ 7.5mA 3 mg per lamp
3	INPUT SIGNAL	Video Sync		RGB Analog (75 ohms, 0.7 / 1.0 Vp-p), DVI (TMDS, 100 ohms) Separate Sync / Composite Sync / SOG Fh = 24 – 82 kHz ; Fv = 50 – 75 Hz
4	COMPATIBILITY	PC Mac		PC Compatibles (from VGA up to 1280x1024 Non Interlaced) Power Mac (up to 1280X1024)
5	RESOLUTION	Recommended		1280x1024 @ 60Hz 640 x 350 @ 70Hz 640 x 400 @ 60, 70Hz 640 x 480 @ 50, 60, 67, 72, 75Hz 720 x 400 @ 70Hz 720 x 480 @ 60Hz 720 x 576 @ 50Hz 800 x 600 @ 50, 56, 60, 72, 75Hz 832 x 624 @ 75Hz 1024 x 768 @ 50, 60, 70, 75Hz 1152 x 864 @ 75Hz 1152 x 870 @ 75Hz 1152 x 900 @ 67Hz 1280 x 720 @ 50, 60Hz 1280 x 768 @ 50, 60, 75Hz 1280 x 960 @ 50, 60, 75Hz 1280 x 1024 @ 50, 60, 75Hz
6	AUDIO	Speaker		1.5W x2
7	CONNECTORS	Video Power	Analog Digital	DB-15 DVI Internal Power Adapter, 3-pin plug (CEE22)
8	POWER	Voltage Consumption	Typ/Max	AC 100-240V (Universal); 50-60 Hz 35 W / 40 W
9	ERGONOMICS	Tilt Swivel Height Adjust		20 ~ -5 degrees 360 degrees 0 ~ 80 mm

10	CONTROLS	Physical OSD Function	Key buttons Main Menu Short cut key	[PW], [Mute], [2], [Up], [Dn], [1] Auto Image Adjust Contrast/Brightness Input Select Analog, Digital Color Adjust sRGB, 9300K, 7500K, 6500K, 5400K, User Color [R, G, B] Information Manual Image Adjust Horizontal Size, H/V Position, Fine Tune, Sharpness Setup Menu Language Select, Resolution Notice, OSD Position, OSD Time Out, OSD Background Memory Recall [1] : Main Menu [2] : Input Select [Up] or [Dn] : Contrast / Brightness [Up] + [Dn] : Recall both of Contrast and Brightness to default [1] + [2] : Toggle 720x400 and 640x400 mode [1] + [Up] + [Dn] : Auto White Balance [1] + [Dn] : Power Lock [1] + [Up] : OSD Lock
11	BANDWIDTH			135 MHz
12	OPERATING CONDITION	Temperature Humidity		32°F to 104°F (0°C to 40°C) 10% to 90% (no condensation)
13	STORAGE / SHIPPING CONDITION	Temperature Humidity		-4°F to 140°F (-20°C to 60°C) 10% to 90% (no condensation)
14	DIMENSIONS	Physical: (W x H x D) Packing (W x H x D)	Display w Stand Wall Mount	428 mm (W) x 479 mm (H) x 230 mm (D) 16.8" (W) x 18.8" (H) x 9.0" (D) 428 mm (W) x399 mm (H) x 68 mm (D) 16.8" (W) x 15.7" (H) x 2.6" (D) 486 mm (W) x 590 mm (H) x 278 mm (D) 19.13" (W) x 23.23" (H) x 10.94" (D)
15	WEIGHT		Net Gross	6.0Kg (13.33 lbs) 7.2Kg (16 lbs)
16	REGULATIONS			UL/CUL, FCC (ICES-003B), CB, CE, TCO'03 TUV/GS, TUV ERGO(covers ISO13406-2 & MPRII), IRAM, VCCI, GOST-R, HYGIENIC (20 copies), Energy Star, CCC, BSMI, PSB, C-TICK, SASO, WEEE, RoHS
17	RELIABILITY	MTBF		100,000 Hr (Excluding Panel).
18	POWER SAVING FUNCTION	"On" " Active Off" "Off"	Blue Amber Off	Normal ≤1 W ≤1 W









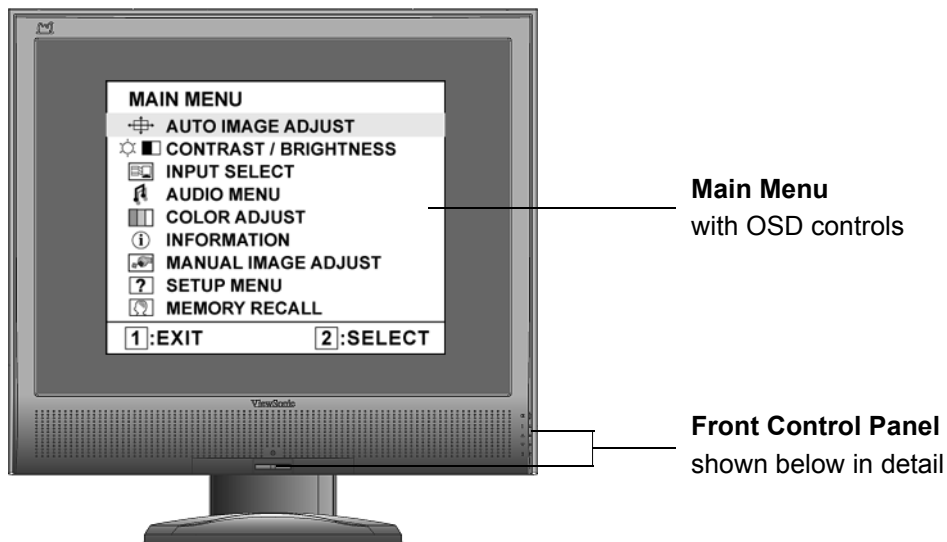

18	POWER SAVING FUNCTION	"On" " Active Off" "Off"	Blue Amber Off	Normal ≤ 1 W ≤ 1 W
19	LOGISTICS	Container Load (20' / 40') Pallet Load UPC Code Serial Format EDID Code Country of origin	Standard	260 / 624 pieces 26 pieces 76690722783 3 QC2 Byte 10 – 0 x 1E, Byte 11 – 0 x 99 China
20	Wall Mount	VESA		100mm x 100mm
21	OTHERS			DDC/2B, KENSINGTON MicroSaver Security Compatible, WorldWide Model.
22	Package Contents	LCD Display Power Cable Video Cable Audio Cable Quick Start Guide ViewSonic Wizard CD-ROM		
23	Packaging Information	Carton -- One piece construction with signal wall, 0.65 Kg Plastic Handle -- PE-LD, 12g Poly Foam -- EPS, 207g, 2 pices Accessory Plastic Bags -- PE-LD, 2g The PE bag that cover monitor -- PE-LD, 18g Pallet (M Model) -- Fumigation wood, 22.5Kg Pallet (Others) -- Poplar, 22.5Kg		

3. Front Panel Function Control Description

Adjusting the Screen Image

Use the buttons on the front control panel to display and adjust the OSD controls which display on the screen. The OSD controls are explained at the top of the next page and are defined in “Main Menu Controls” on page 10.



-  Standby Power On/Off
-  Power light
-  Blue = ON
-  Orange = Power Saving
-  Audio Mute button turns the sound off
-  Displays the Main Menu or exits the control screen and saves adjustments.
-  Scrolls through menu options and adjusts the displayed control.
-  Also a shortcut to display the Contrast adjustment control screen.
-  Displays the control screen for the highlighted control.
-  Also toggles between two controls on some screens.

Do the following to adjust the display setting:

1. To display the Main Menu, press button [1].

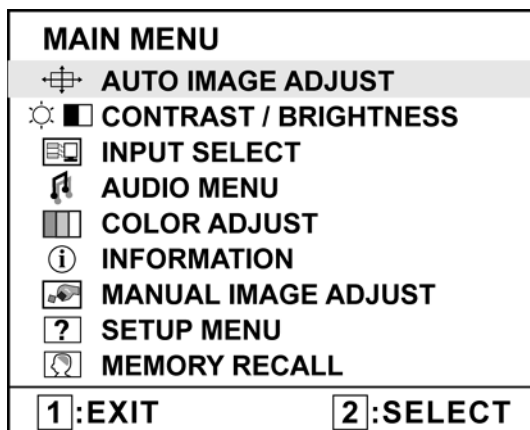

NOTE: All OSD menus and adjustment screens disappear automatically after about 15 seconds. This is adjustable through the OSD timeout setting in the setup menu.

2. To select a control to adjust, press▲or▼to scroll up or down in the Main Menu.
3. After the desired control is selected, press button [2]. A control screen like the one shown below appears.

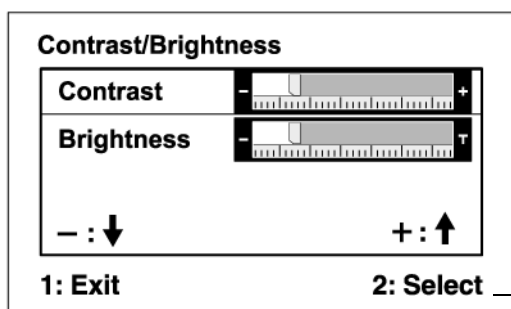

The command line at the bottom of the control screen tells what to do next from this screen. You can toggle between control screens, adjust the selected option, or exit the screen.







4. To adjust the setting, press the up ▲ or down ▼ buttons.
5. To save the adjustments and exit the menu, press button [1] *twice*.

The following tips may help you optimize your display:

- Adjust the computer's graphics card so that it outputs a 1280 x 1024 @ 60Hz video signal to the LCD display. (Look for instructions on “changing the refresh rate” in the graphics card's user guide.)
- If necessary, make small adjustments using H. POSITION and V. POSITION until the screen image is completely visible. (The black border around the edge of the screen should barely touch the illuminated “active area” of the LCD display.)

Main Menu Controls

Adjust the menu items shown below by using the up ▲ and down ▼ buttons.

Control	Explanation
	Auto Image Adjust sizes and centers the screen image automatically.
	Contrast adjusts the difference between the image background (black level) and the foreground (white level).
	Brightness adjusts background black level of the screen image.
	Input Select toggles between inputs if you have more than one computer connected to the VG930m.
	Audio Adjust Volume increases the volume, decreases the volume, and mutes the audio. Mute temporarily silences audio output.
	Color Adjust provides several color adjustment modes, including preset color temperatures and a User Color mode which allows independent adjustment of red (R), green (G), and blue (B). The factory setting for this product is 6500K (6500 Kelvin).

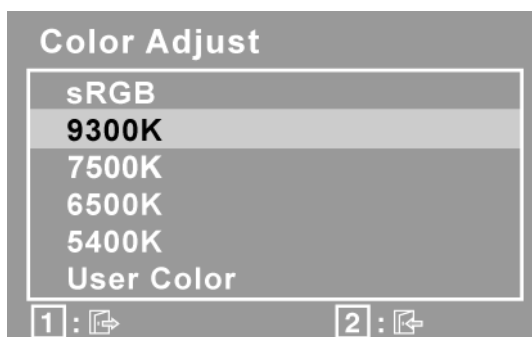

sRGB-This is quickly becoming the industry standard for color management, with support being included in many of the latest applications. Enabling this setting allows the LCD display to more accurately display colors the way they were originally intended. Enabling the sRGB setting will cause the Contrast and Brightness adjustments to be disabled.

9300K-Adds blue to the screen image for cooler white (used in most office settings with fluorescent lighting).

7500K-Adds blue to the screen image for cooler white (used in most office settings with fluorescent lighting).

6500K-Adds red to the screen image for warmer white and richer red.

5400K-Adds green to the screen image for a darker color.

User Color Individual adjustments for red (R), green (G), and blue (B).

1. To select color (R, G or B) press button [2].

2. To adjust selected color, press▲and▼.

Important: If you select RECALL from the Main Menu when the product is set to a Preset Timing Mode, colors return to the 6500K factory preset.



Information displays the timing mode (video signal input) coming from the graphics card in the computer, the LCD model number, the serial number, and the ViewSonic® website URL. See your graphics card's user guide for instructions on changing the resolution and refresh rate (vertical frequency).
NOTE: VESA 1280 x 1024 @ 60Hz (recommended) means that the resolution is 1280 x 1024 and the refresh rate is 60 Hertz.

Information		
H. Frequency:	XX	kHz
V. Frequency:	XX	Hz
Resolution:	XXX	
Pixel Clock:	XXXXXXXXXX	MHz
Serial Number:	XXXXXXXXXXXX	
Model Number:	XXXXXXXXXXXX	
www.ViewSonic.com		1: Exit



Manual Image Adjust

Manual Image Adjust	
	H. Size
	H./V. Position
	Fine Tune
	Sharpness
1: Exit	
2: Select	



H. Size (Horizontal Size) adjusts the width of the screen image.



H./V. Position (Horizontal/Vertical Position) moves the screen image left or right and up or down.

H./V. Position	
H. Position	
V. Position	
- : ↓	+ : ↑
1: Exit	
2: Select	

Control	Explanation
---------	-------------



Fine Tune sharpens the focus by aligning text and/or graphics with pixel boundaries.

NOTE: Try Auto Image Adjust first.



Sharpness adjusts the clarity and focus of the screen image.



Setup Menu displays the menu shown below:

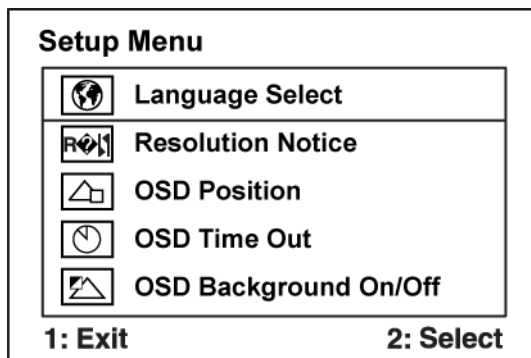

Language Select allows the user to choose the language used in the menus and control screens.



Resolution Notice allows the user to enable or disable this notice.

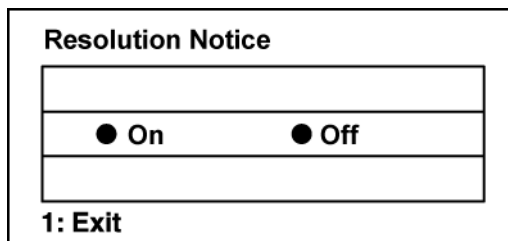

If you enable the Resolution Notice shown above and your computer is set at a resolution other than 1280 x 1024, the following screen appears.

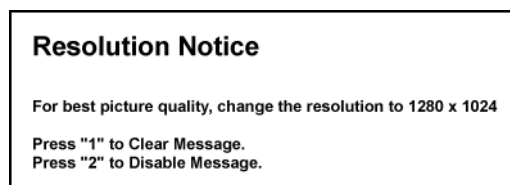

OSD Position allows the user to move the OSD menus and control screens.



OSD Timeout sets the length of time the OSD screen is displayed. For example, with a “30 second” setting, if a control is not pushed within 30 seconds, the display screen disappears.

Control	Explanation
---------	-------------



OSD Background allows the user to turn the OSD background On or Off.



Memory Recall returns the adjustments back to factory settings if the display is operating in a factory Preset Timing Mode listed in the Specifications of this manual.

4. Circuit Description

4.2 Power Board

Electric Spec :

Connection	9Pin NO.	6Pin NO.	Symbol	Description
CON802	9	NC	DC-Output	24.0±10%Vdc / 50mA (Optional)
	8	NC	DC-Output	12±10%Vdc / 200mA (Optional)
	7	6	BL-Adj	Luminance Control (0Vdc~3.3Vdc)
	6	5	ON/OFF	ON : 3.3Vdc or 5.0Vdc ; OFF : 0V
	4. 5	3. 4	DC-Output	5.0±5%Vdc / 2500mA
	2. 3	1. 2	GND	GND
	1	NC	DC-Output	-8±10%Vdc / 100mA(Optional)
CON901~CON904	1	1	H.V	High Voltage
	2	2	Return	Return Pin

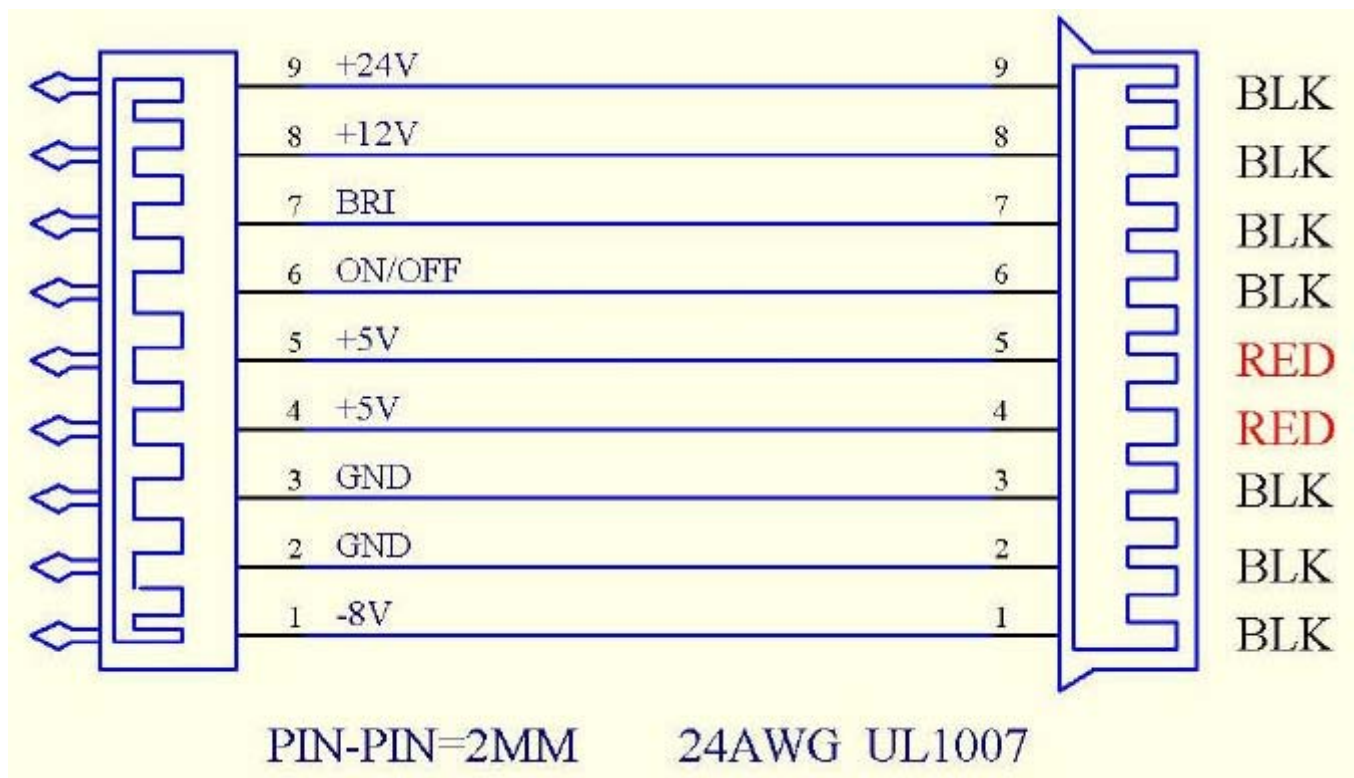

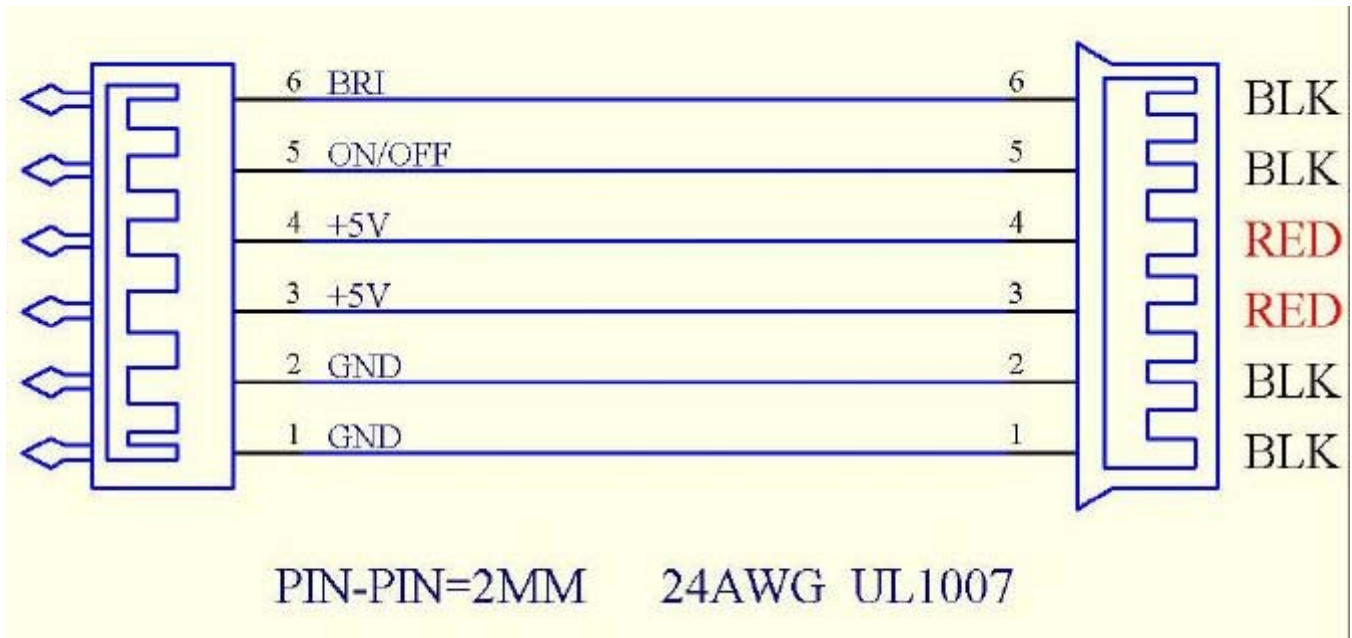

ELECTRIC TEST

1. POWER TEST :

1-1 . OUTPUT VOLTAGE TEST : Output 24V connect 50mA, CON801 Input

1-2 . HI-POT TEST :

1) Test Requirements – Input Voltage : 3.0KVdc

– Measurement Time : 3sec

– Temperature : 25°C± 5°C

2) A method of measurement : Injection voltage between Utility (Line and Neutral short) and output line (short between + and -)

3) Criterion for Judging : PASS

1-3 . SHORT TEST PROTECT :

24Vdc SHORT to GND , POWER PROTECT .

12Vdc SHORT to GND , POWER PROTECT .

5Vdc SHORT to GND , POWER PROTECT .

-8Vdc SHORT to GND , POWER PROTECT .

1-4 . LOW POWER CONSUMPTION: Input 240Vac/50Hz Output NO LOAD , Power Consumption ≤0.5W . 1-5 .

GROUND TEST :

1) Test Requirements – Input Current : 25A

– Measurement Time : 3sec

– Temperature : 25°C± 5°C

2) A method of measurement : Injection current between Utility F.G. (inlet socket F.G.) and output ground (heat sink)

3) Criterion for Judging : ≤Resistor 100mΩ

1-6 . Insulation Resistance

1) Test Requirements – Input Voltage : 500Vdc

– Temperature : 25°C± 5°C

2) A method of measurement : Test between Utility (live and neutral short) and output line (+ and - short).
(insulation resistance test)

3) Criterion for Judging : Insulation resistance $\geq 100M\Omega$ 2. INVERTER TEST: 2-1. OPEN LAMP PROTECT TEST :

Test Condition : ON/OFF PIN=3.3Vdc or 5.0Vdc , BL-Adj PIN=3.3Vdc or 5.0Vdc . Result : CN901~CN904 OPEN , INVERTER TURN ON CONTINUE 1~2 SECONDS SHUT DOWN .

2-2. KICK-OFF VOLTAGE TEST : Test Condition : ON/OFF PIN=3.3Vdc or 5.0Vdc , BL-Adj PIN=3.3Vdc or 5.0Vdc .

Result :

CN901~CN903 TEST CN904 H.V PIN Output Voltage $\geq 1.5KV$ rms.

CN902~CN904 CONNECT TEST CN901 H.V PIN Output Voltage $\geq 1.5KV$ rms .

CN903 . CN904 . CN901 CONNECT TEST CN902 H.V PIN Output Voltage $\geq 1.5KV$ rms .

CN901 . CN902 . CN904 CONNECT TEST CN903 H.V PIN Output Voltage $\geq 1.5KV$ rms .

2-3 . OUTPUT CURRENT TEST :

Test Condition				Result
CN802 Pin 24V GND	CN802 BL-Adj PIN	CN802 Pin ON/OFF		CN901~CN904
22~28Vdc	3.3Vdc	3.3Vdc or 5.0Vdc	17" or 19" PANEL	6.5±0.5mA / 50±5KHz 7.0±0.5mA / 50±5KHz 7.5±0.5mA / 50±5KHz MEET L NEED Jumper
22~28Vdc	0Vdc	3.3Vdc or 5.0Vdc	17" or 19" PANEL	3.5±0.5mA
22~28Vdc	0Vdc or 3.3Vdc	0Vdc	17" or 19" PANEL	NO Output

OLD TEST

CN801 Input 100~240Vac , CN802 BL-Adj Pin CONNECT 3.3Vdc , CN802 ON/OFF Pin CONNECT 3.3Vdc OR 5.0Vdc ,

ATTENTION

1. WHEN OPERATION, WEAR STATIC ELECTRICITY RING AND KEEP GND.
2. TO PREVENT A SHORT CIRCUIT.
3. CON801 / C809 / C802 / C803 / BD801/ Q801 / T801/T802/T901/ THESE LARGE VOLUM MUST WEIGHT A LOT

4.3 Scaler Board

- 17 " and 19 " LCD MONITOR
- WORK ENVIROMENT 1. WORK ENVIROMENT TEMPERATURE : 0 °C ~40 °C 2. WORK ENVIROMENT humidity : 30% ~ 85% RH . 3. STORE ENVIROMENT TEMPERATURE : -25°C ~+85°C 4. STORE ENVIROMENT humidity : 30% ~ 90% RH
- INPUT REQUIREMENT: AC Input Voltage :100Vac ~240Vac / 50~60Hz

■ **SPEC :**

NO	List	CH 1	CH 2	CH 3	CH4
1	Channel Name	-8V(Optional)	+5V	+12V(Optional)	+24V
2	OUTPUT VOLTAGE SPEC	-8V±10%	+5V±5%	+12V(11.5~13.5V)	+24V±10%
3	OUPUT CURRENT SPEC	50mA	2500mA	200mA	1. 900mA for Inverter 2. 50mA for SIP PANEL(Optional)
4	LOWEST WORK CURRENT	10mA	400mA	50mA	10mA
5	WAITTING 5V Load=50~80mA ,	7V ~ 12V	4.75V ~ 5.25V	11.5V ~ 16V	22.6V~30V
6	Ripple & Noise	200mVp-p	100mVp-p	300mVp-p	300mVp-p

- WAITTING MERIT : AC INPUT 240Vac , NO Load
- (L=80mm) INTRODUCTION :

PIN NO. FOR RSDS	9	8	7	6	5	4	3	2	1
PANEL SPEC	24V	12V	ADJ	On/Off	5V		GND		-8V
PIN NO. FOR LVDS	NC	NC	6	5	4	3	2	1	NC
PANEL SPEC	NC	NC	ADJ	On/Off	5V		GND		NC

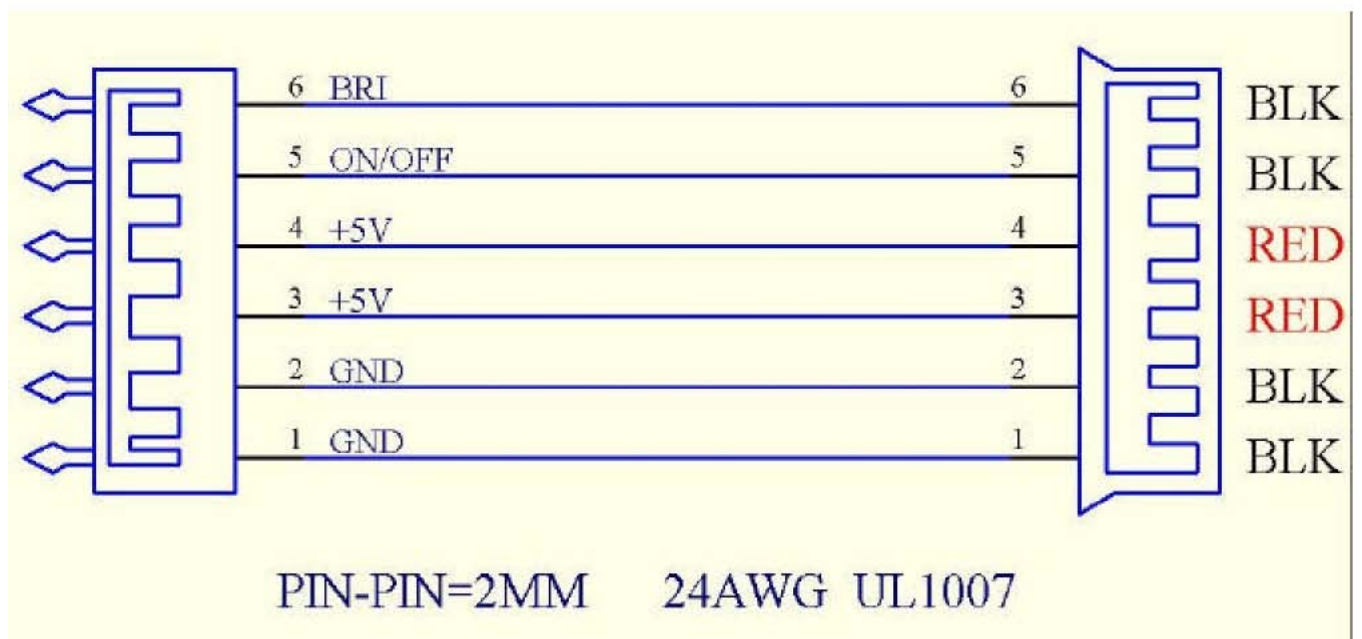
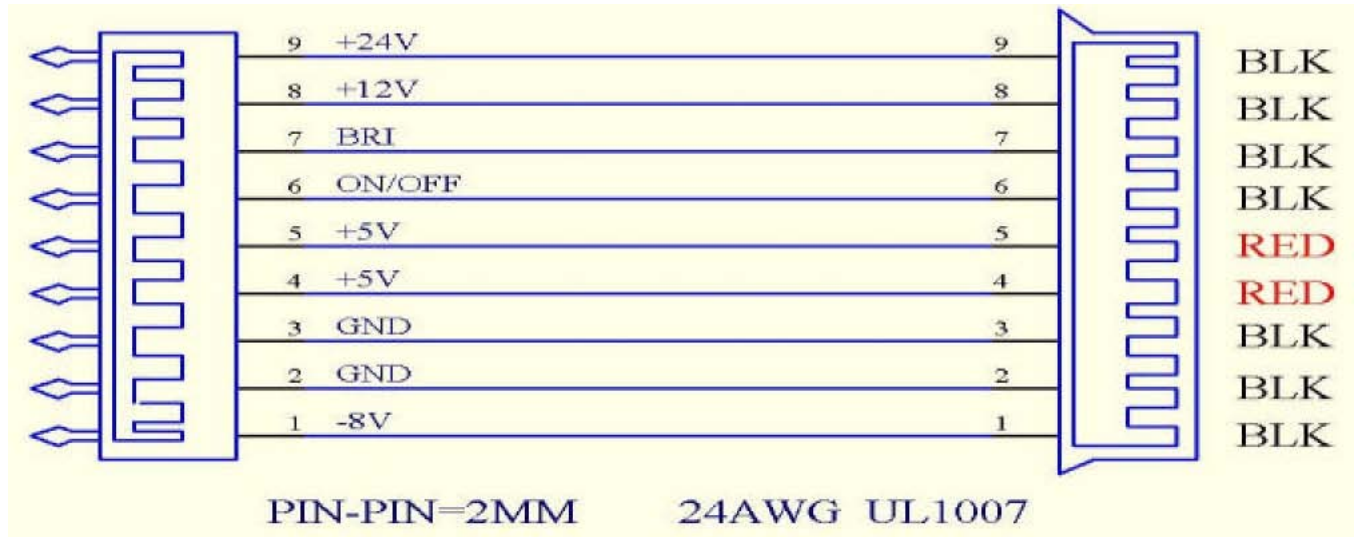

- OUTPUT VOLTAGE RISE TIME AC INPUT 90 Vac ~264Vac, <100mS .
- AC ELECTRICITY TIME DELAY WHEN AC INPUT , OUTPUT VOLTAGE SHOULD WITHIN 1.5S .
- SURGE ELECTRI CURRENT AC INPUT 240Vac .
- PROTECT FOR SHORT CIRCUIT
- PROTECT FOR OVER-CURRENT

Input Voltage(V)	Output(V)	Output Current limits (A)
90Vac~264Vac 47~63Hz	+24	<2A
	+12	<4
	+5	<6
	-8	<4

■ **PROTECT FOR OVER-CURRENT**

Output Voltage (V)	Voltage limit (V)
24	38
12	20

- Hi-POT TEST 3KVac / 3Sec
- INSULATION IMPEDANCE INPUT 500Vdc , INSULATION IMPEDANCE > 100M Ohm
- GND TEST INPUT 25A_{dc} / 3 Sec , RESISTANCE CONNECT GROUNDS <100m Ohm
- INVERTER INTRODUCTION : 17 " and 19 " PANEL LCD MONITOR

1) 1.-4 lamp type of 17 " and 19 " PANEL

2) 2. SPEC REQUIREMENT

	Items	Sign.	Condition	Min	Typ	Max	
1	Output Current (mA)	Lout1.2	Vin=24V	BL-ADJ=0V	3.0	3.5	4.0
				BL-ADJ=3.3V	6.0	6.5	7.5
					6.5	7.0	7.5
					7.0	7.5	8.0
2	Output Voltage (Vrms)		Vin=24V	BL-ADJ=3.3V	560	660	760
3	Lamp Frequency (kHz)	f	Vin=24V	BL-ADJ =3.3V	45	50	55
4	On/Off Control	On	Vin=24V, On/Off=3.3V or 5V		Normal Operation		
		Off	Vin=24V, On/Off=0V		Shunt-down (Lamp off)		
5	Dim Adjust (Lamp Current Control)	BL-ADJ	BL-ADJ = 3.3V, Max Current		0V ~ 3.3V		
			BL-ADJ = 0V, Min Current				
6	Kick-Off Voltage(Vrms)	Vk-off	Kick-Off		More than 1500		

4.4 EDID Data

[DDC#1]

```
00 FF FF FF FF FF FF 00 5A 63 1E 99 01 01 01 01
01 10 01 03 80 26 1E 78 2E C5 56 A4 54 4A 9D 24
14 4F 54 BF EF 80 81 80 81 40 71 4F 31 0A 01 01
01 01 01 01 01 01 30 2A 00 98 51 00 2A 40 30 70
13 00 78 2D 11 00 00 1E 00 00 00 FF 00 51 43 32
30 36 30 31 30 30 30 30 31 0A 00 00 00 FD 00 32
4B 1E 52 0E 00 0A 20 20 20 20 20 20 00 00 00 FC
00 56 47 39 33 30 6D 2D 33 0A 20 20 20 20 00 3E
```

[DDC#1]

```
00 FF FF FF FF FF FF 00 5A 63 1E 99 01 01 01 01
01 10 01 03 0E 26 1E 78 2E C5 56 A4 54 4A 9D 24
14 4F 54 BF EF 80 81 80 81 40 71 4F 01 01 01 01
01 01 01 01 01 01 30 2A 00 98 51 00 2A 40 30 70
13 00 78 2D 11 00 00 1E 00 00 00 FF 00 51 43 32
30 36 30 31 30 30 30 30 31 0A 00 00 00 FD 00 32
4B 1E 52 0E 00 0A 20 20 20 20 20 20 00 00 00 FC
00 56 47 39 33 30 6D 2D 33 0A 20 20 20 20 00 E9
```

4.5 Interface

4.5.1 Pin Assignment

D-SUB connector:CN2

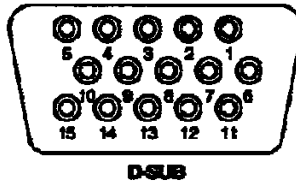

Pin	Input Signal	Pin	Input Signal	Pin	Input Signal
1	Red video	6	Red Video Ground	11	Open
2	Green Video/Sync on Green	7	Green Video Ground	12	Data line (SDA)*
3	Blue Video	8	Blue Video Ground	13	H-Sync
4	Ground	9	+5V (for cable detect)	14	V-Sync
5	Ground	10	Connector detector	15	Clock line (SCL)*

*Compliant to VESA DDC.

4.5.2 Audio Input (line-in)

Item	Specifications
Input Voltage	1 Vrms
Output Power	1 W dual channel output

5. Adjusting Procedure

Setup Procedure.

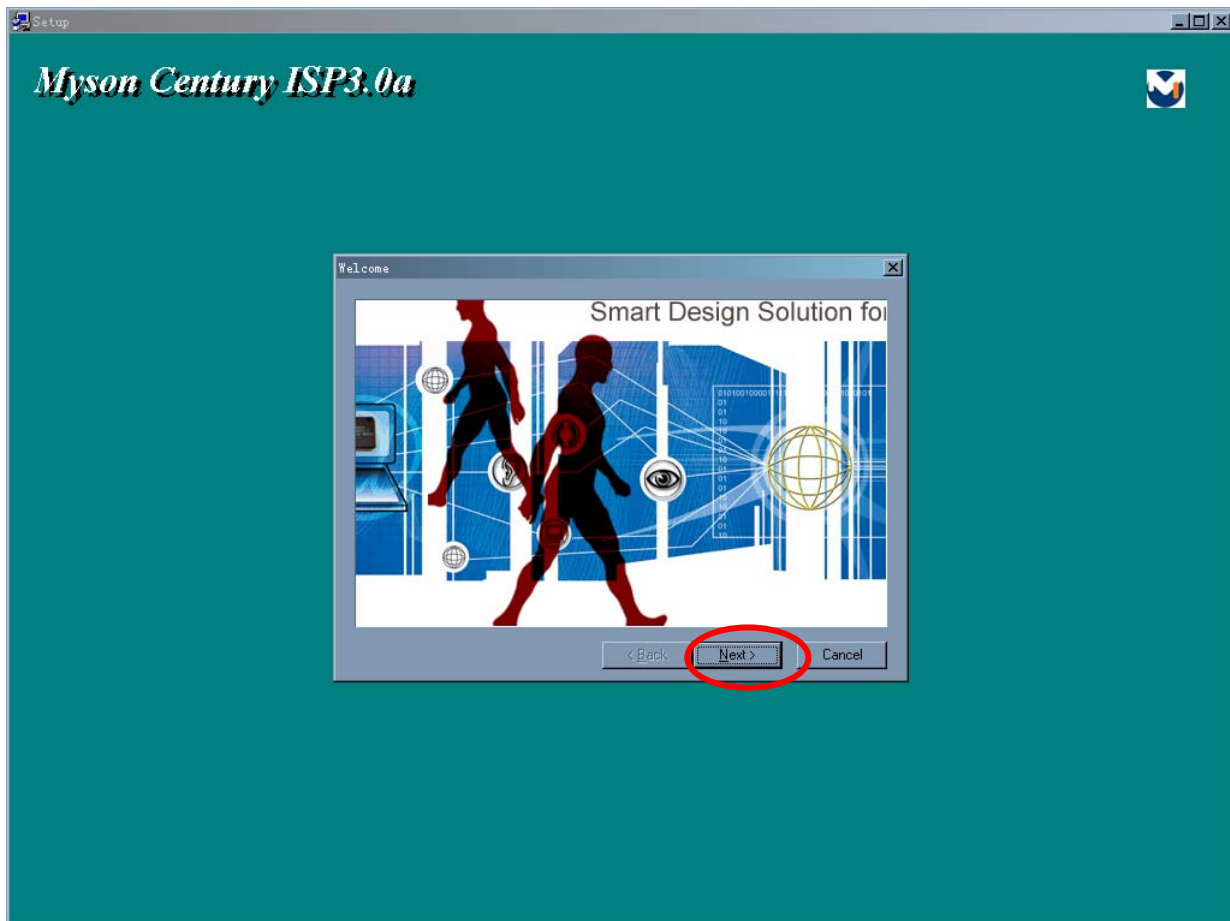
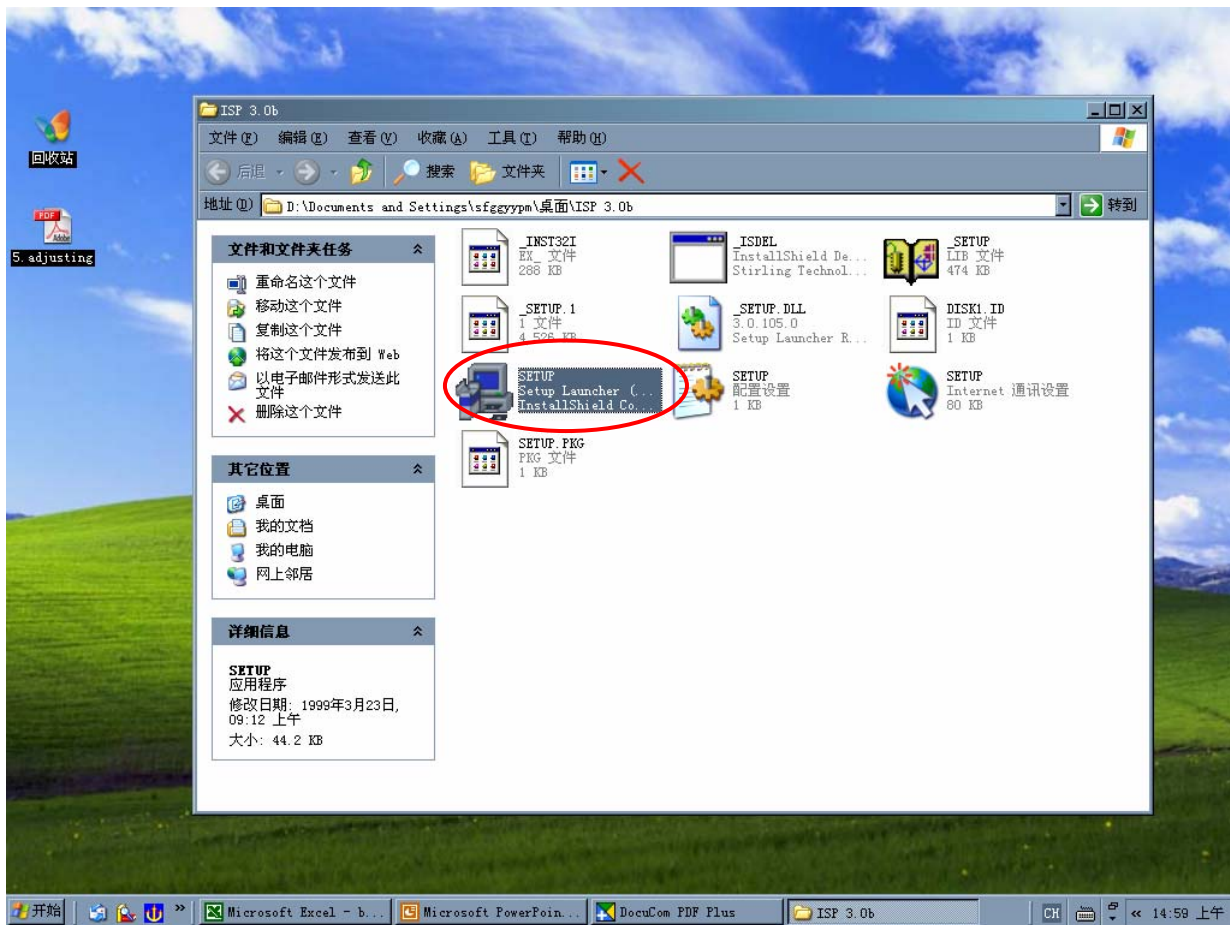

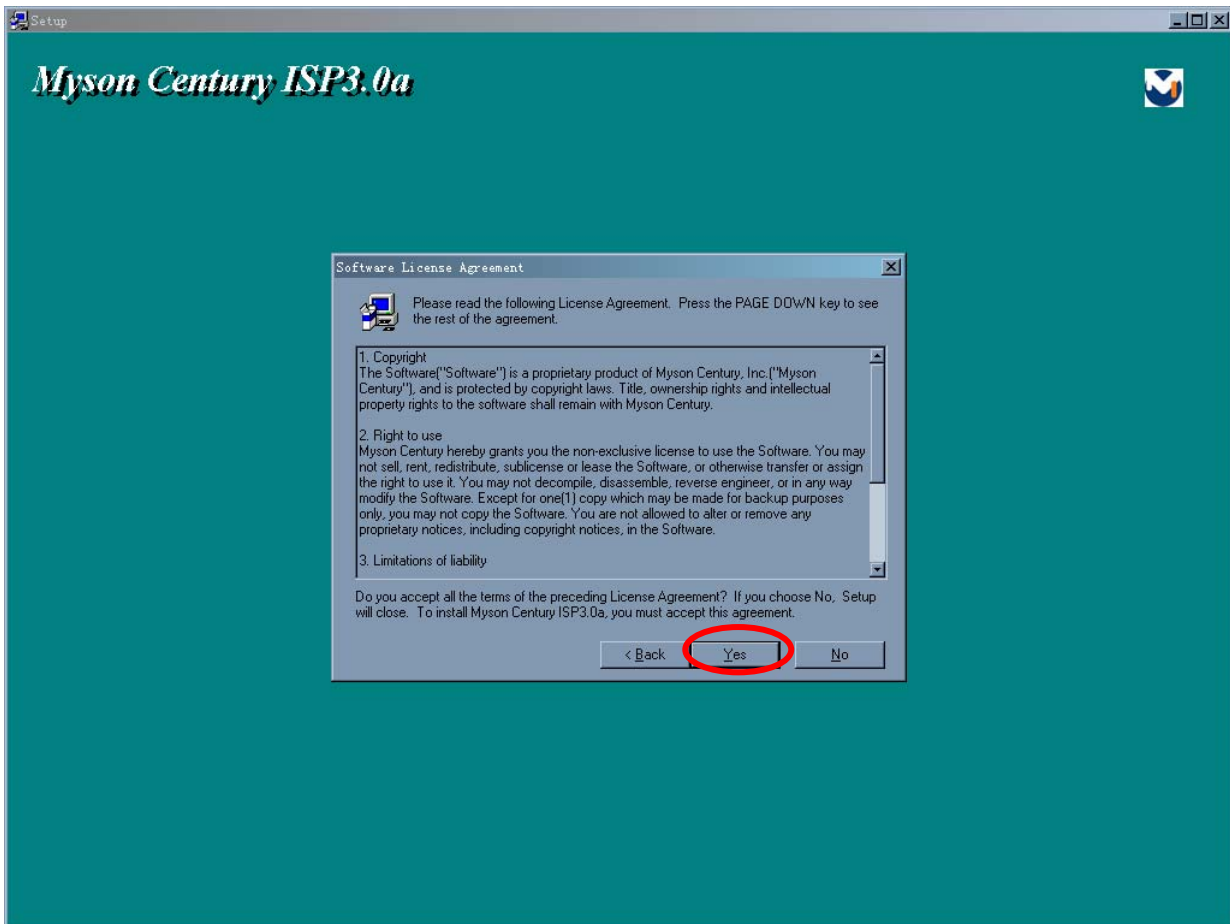
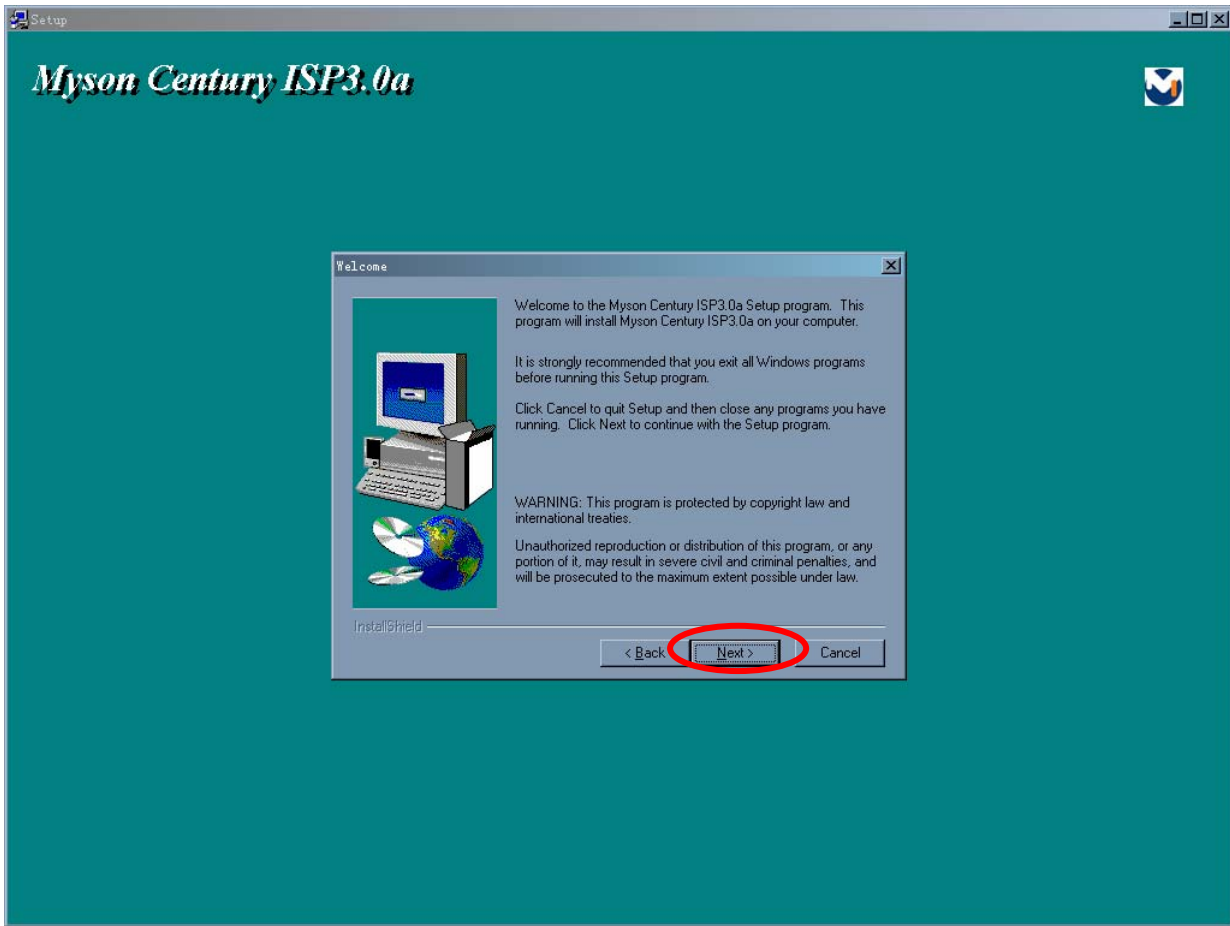

Installation will create a icon for ISP application in “START MENU”\PROGRAM

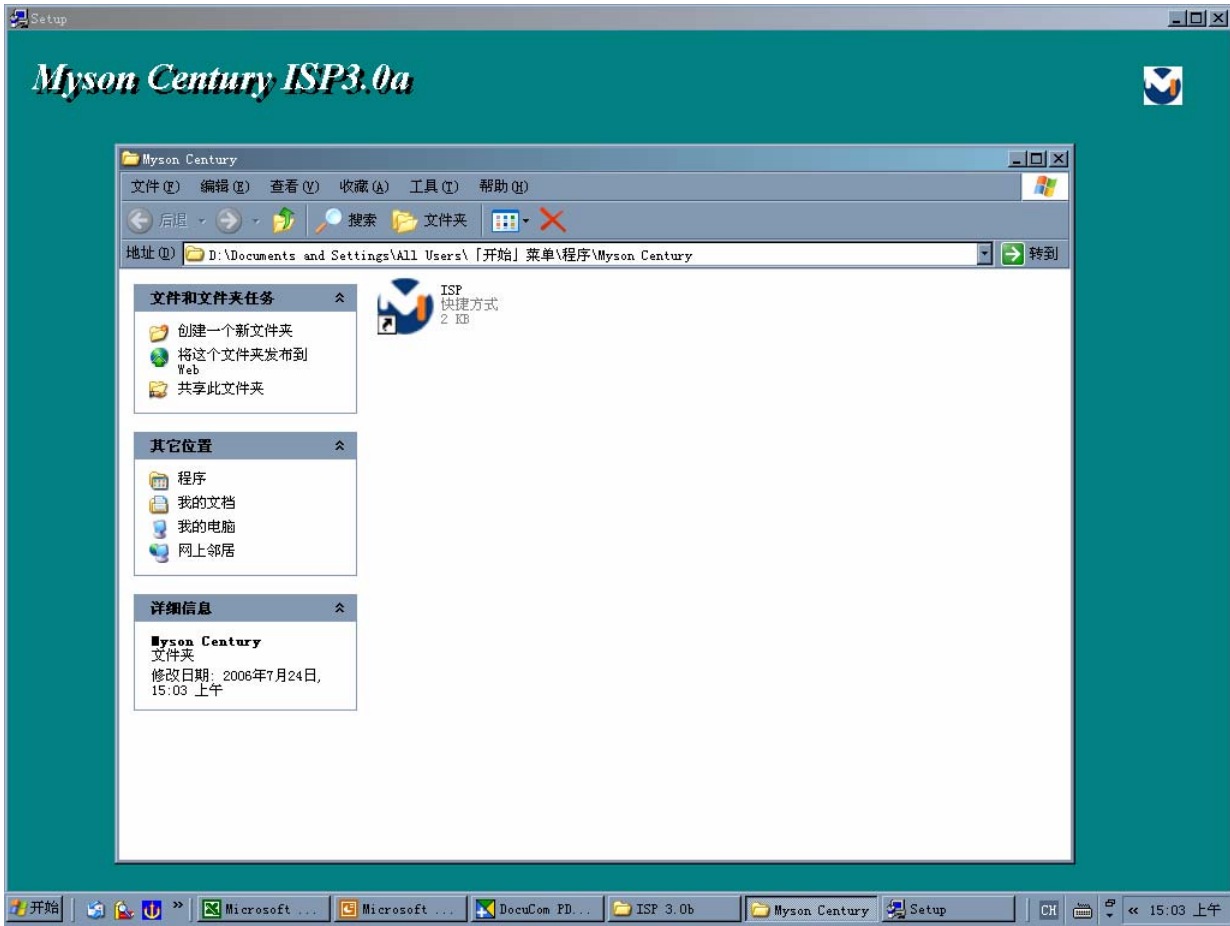

Press “finish” button exit setup

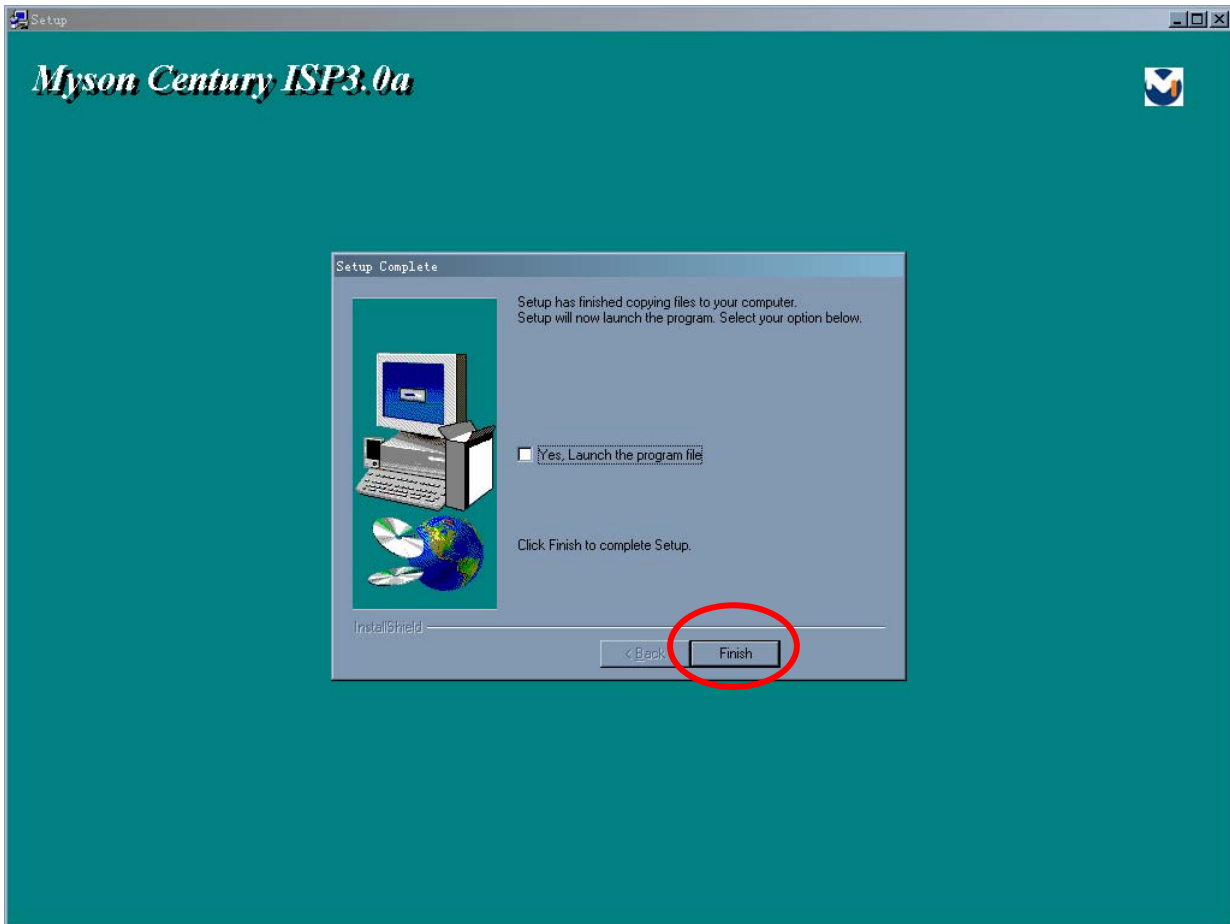

Firmware Update Procedure

17. 1 The monitor's firmware update for VG930 have two method.

1.1. Download the MCU IC by the fire machine. This procedure is finished in SMT .

1.2. ISP Method. When the monitor's BIOS isn't exist or firmware isn't final program, this method is worked by ISP Cord with monitor

17.2.1 Equipment Needed

- USB cable for print port *1
- VGA cable*1
- LPT cable (25pin)*1
- AC power cable*1
- ISP fire cord (the fixture is made in TE) for firmware upgrade*1
- Power adapter for firmware upgrade (this adapter is made in TE)*1
- A computer with WindowsXP
- VG930 monitor (no firmware)
- a additional monitor for system display
- ISP & ISP3.0 program

2. VG930 monitor upgrade firmware by ISP Cord.

NOTE:

The fixture for firmware upgrade provide two different method to fire. Please check you monitor's Main board, refer to MCU-RSIC type and choose the method.

Below form appear the relation between the method and the MCU-RSIC type

METHOD	MCU	ASIC	JUMPER
A	MYSON	M-STAR & NOVATEK	PIN2-3 CLOSED
B	OTHER	REALTEK	PIN1-2 CLOSED

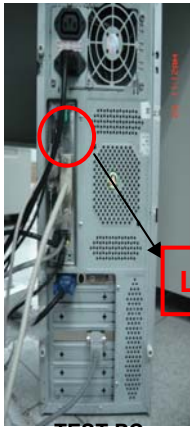

TEST PC



Fixture ISP_CORD



Fixture POWER_ADAPTER



LPT Cable



AC power Cable



VGA Cable



USB FOR PRINT

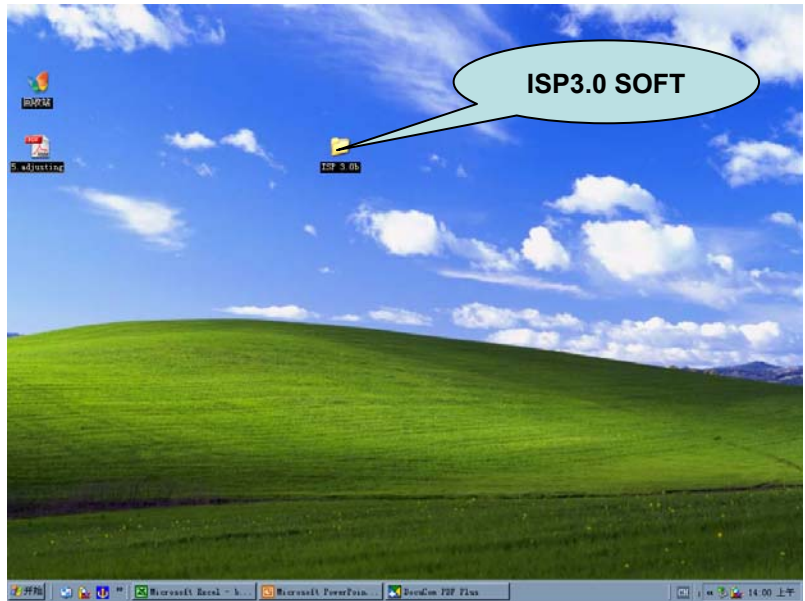

17.2.4. Firmware Upgrade Procedure

Step17.2.4.1 connect all kinds of cable with PC ok, turn on the computer and open the ISP.EXE

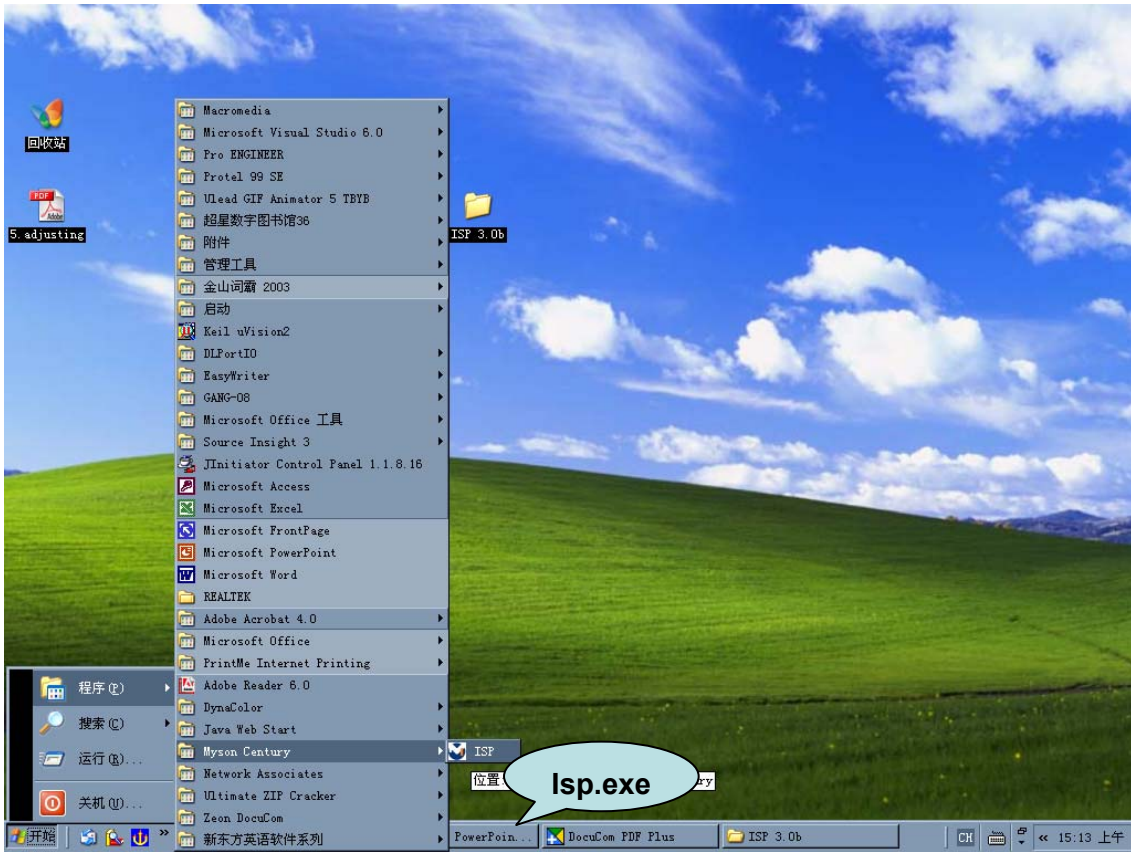

Step17.2.4.2 The “ISP.EXE” application is running as the below picture. Press the “create security file” Button to create a security file

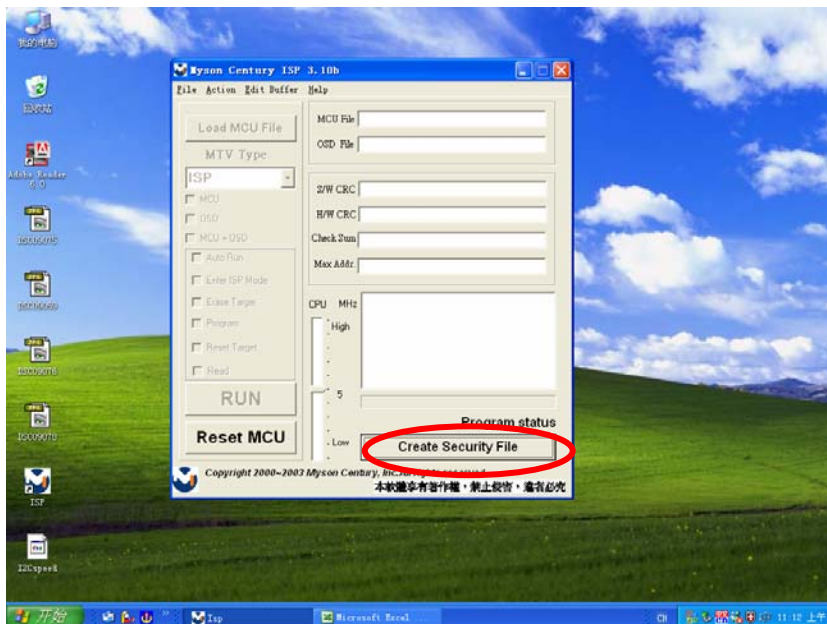

Step17.2.4.3 In this dialog box. at first , key in or press the “up toward” key to change the command number to 4. second, key “94,94,AC,CA,53”in the ISP slave add. Slave b add. Command1.Command2. command3.table, the below form showed the data list

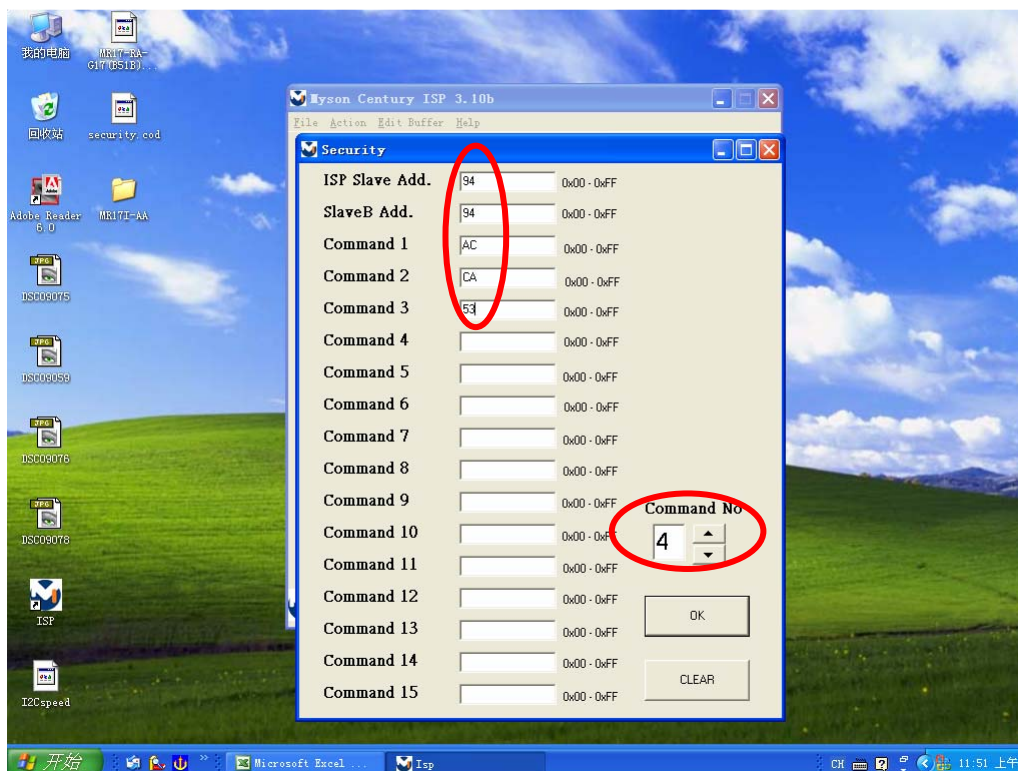

Setp17.2.4.4 Select MTV Type in the “MTV type” list . VG930 monitor must be choose the “MTV512M64”option

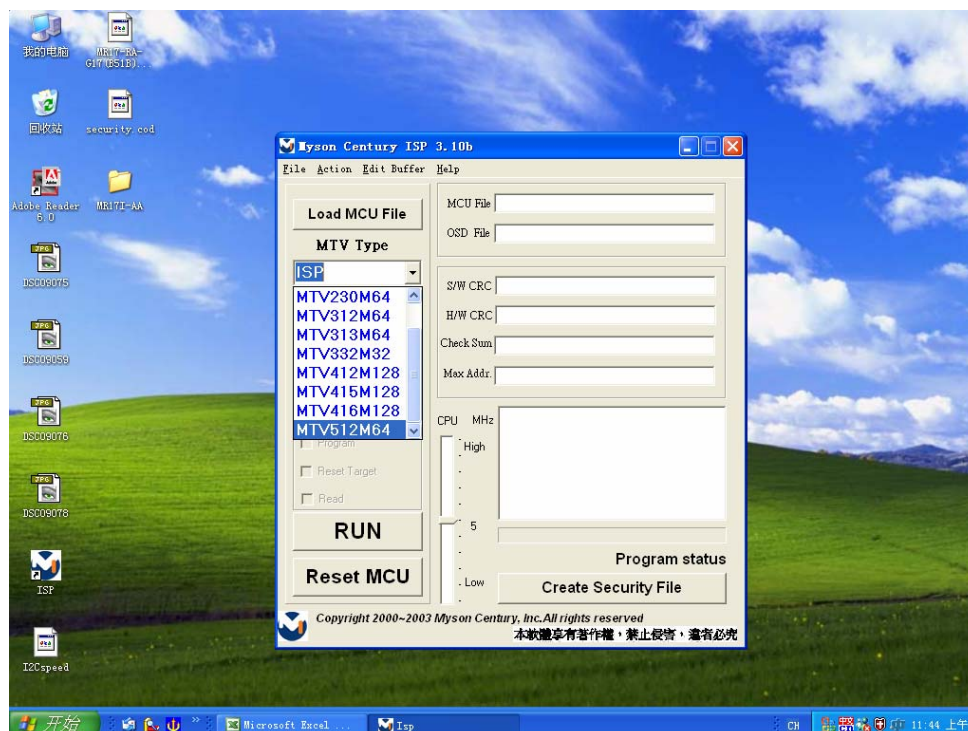

Step17.2.4.5 Load the MCU file to fire. Click the “load MCU file” button to entry to interface of setting current path and select the BIOS file in the disk

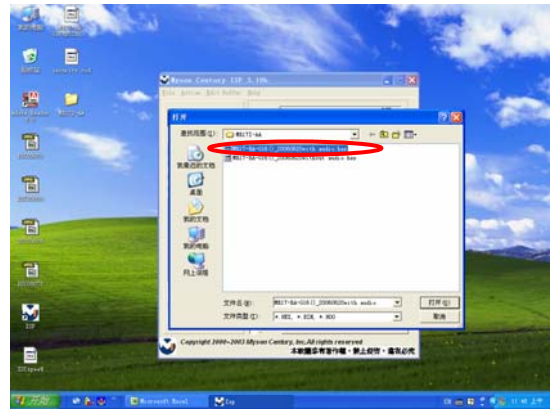

2. Entry to interface of selecting file

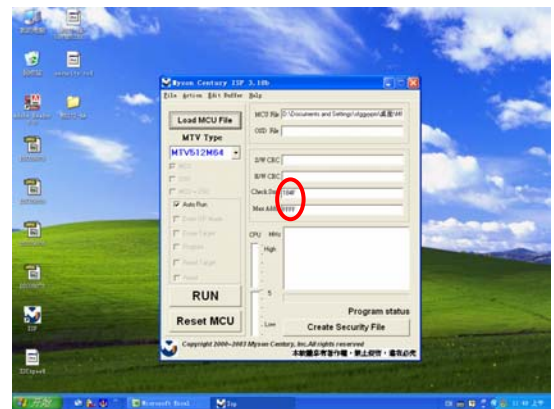

3. Open file and load file ok

4. Check the BIOS checksum

Step17.2.4.6 Select the program upgrade made must be select “autorun” mode at this .

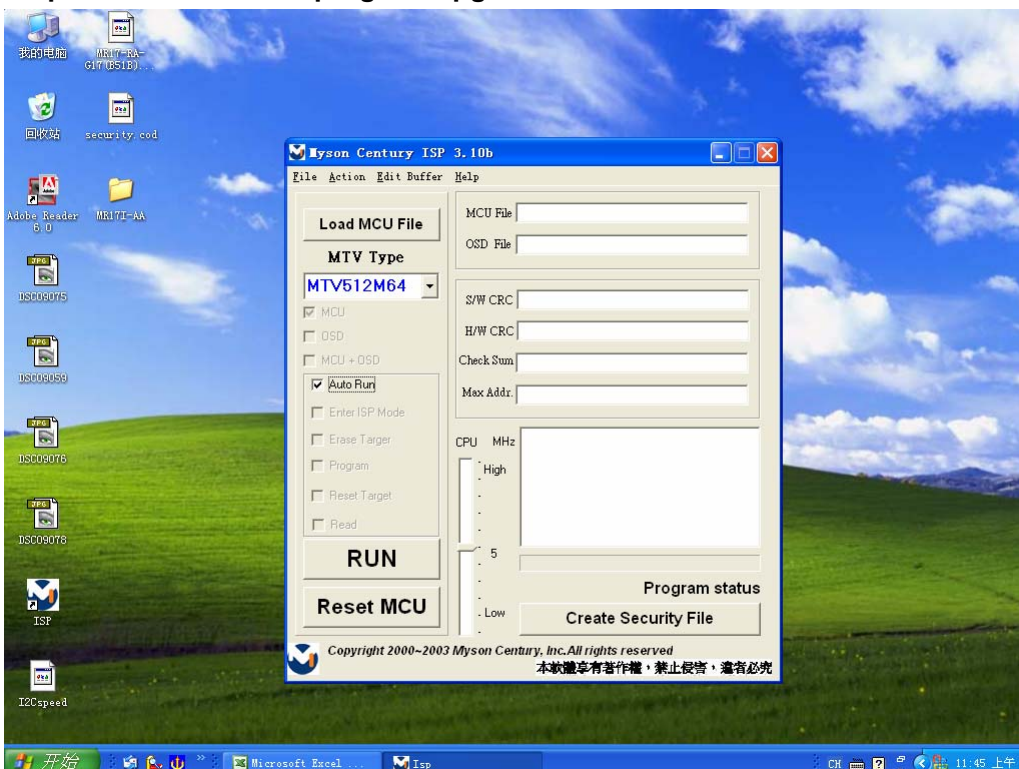

Step17.2.4.7 click the “run” button to upgrade monitor’s firmware.

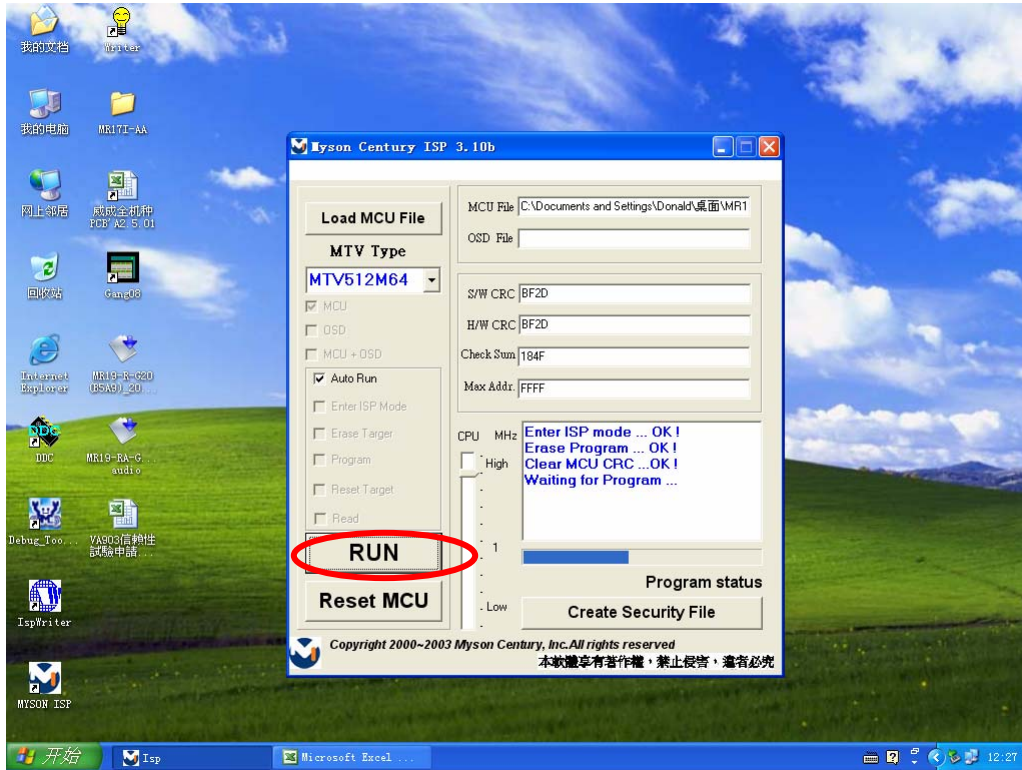

Step17.2.4.8 Firmware is upgraded ok .please check the data of “S/W CRC” “H/W CRC”“CHECKSUM” “MAX ADDR” .

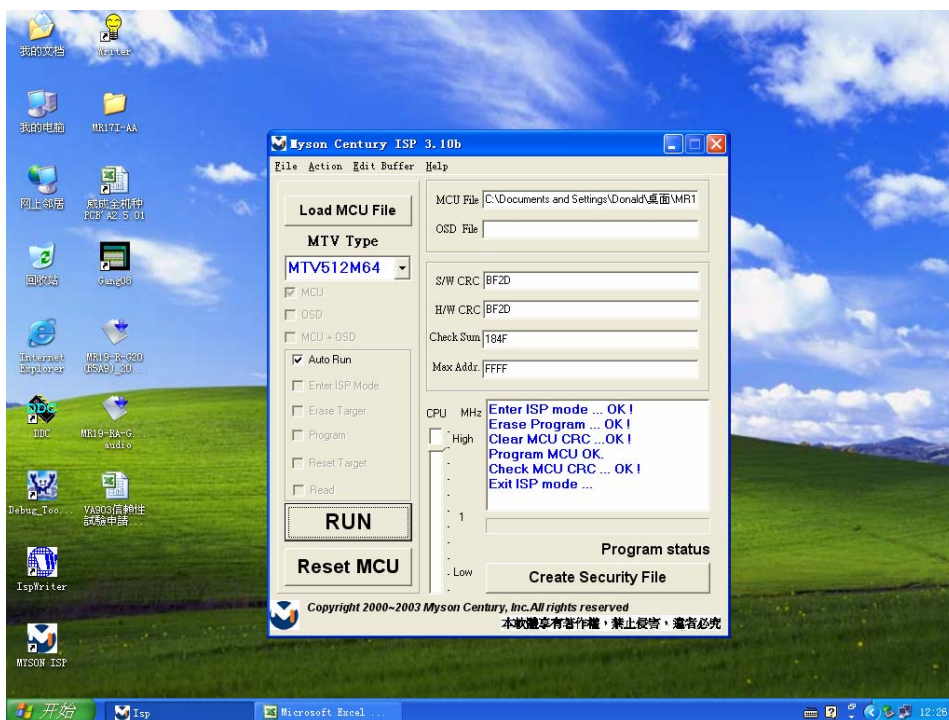

EDID

Note: After having assembled the monitor, please do the DDC Key In procedure. If you find the DDC does not conform to the monitor, please do the DDC Key In again .

17.3. 1 Equipment Needed

- VG730 Series Monitor
- RS232-VGA Cable*1
- RS232-DVI Cable*1
- AC POWER Cable*1
- TEST PC with WindowsXP
- Display Data Channel (D8330 DDC Card) to plug PC_PCI _Slot
- DYNACOLOR DDC Tester System software
- Barcode Scanner *1
- AC POWER Source
- one additional monitor for Test System displaying



PC

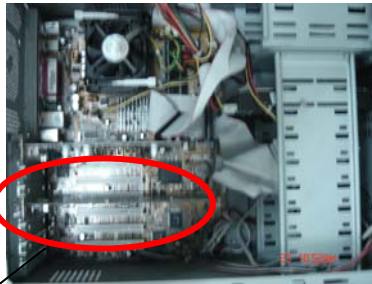

DDC CORD

D8330 CORD



Barcode Scanner



RS232-VGA Cable



AC POWER Cable



RS232-DVI Cable



DDC TESTER SOFT

17.3.2 Setup Procedure

17.3.2.1 Open computer's box cover, plugged D8330 CORD in PCI slot, closed cover and connect AC power , Monitor, Barcode Scanner, Mouse, Keyboard with PC Connect RS232-VGA cable to DDC RS232 OUT port of PC (if you do DDC Key In for D_SUB)

17.3.2.2 Connect RS232-DVI cable to DDC RS232 OUT port of PC (if you do DDC key In for D_DVI).

NOTE:

Barcode Scanner and Keyboard plugged in Keyboard port of computer together

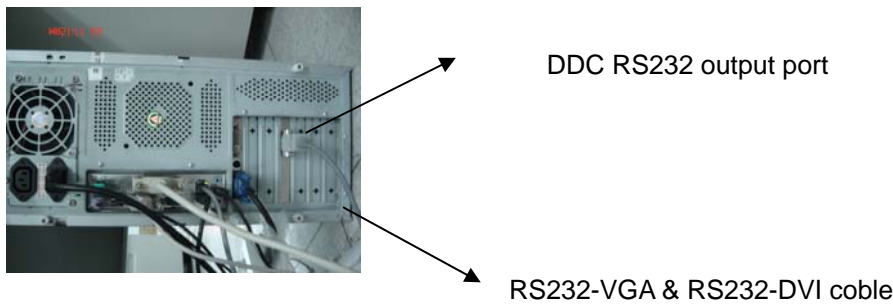

17.3.2.3 DDC TESTER SYSTEM SOFT SETUP(from setup file)

NOTE:

Before install DDC Tester System Soft , please checking the D8330 CORD is plugged Or the DDC Tester application could't be run .

17.3.2.3.1 Install DDC Tester System by selecting and checking setup.exe icon. Press “YES” or “NEXT” Buttons until the installation is completed.

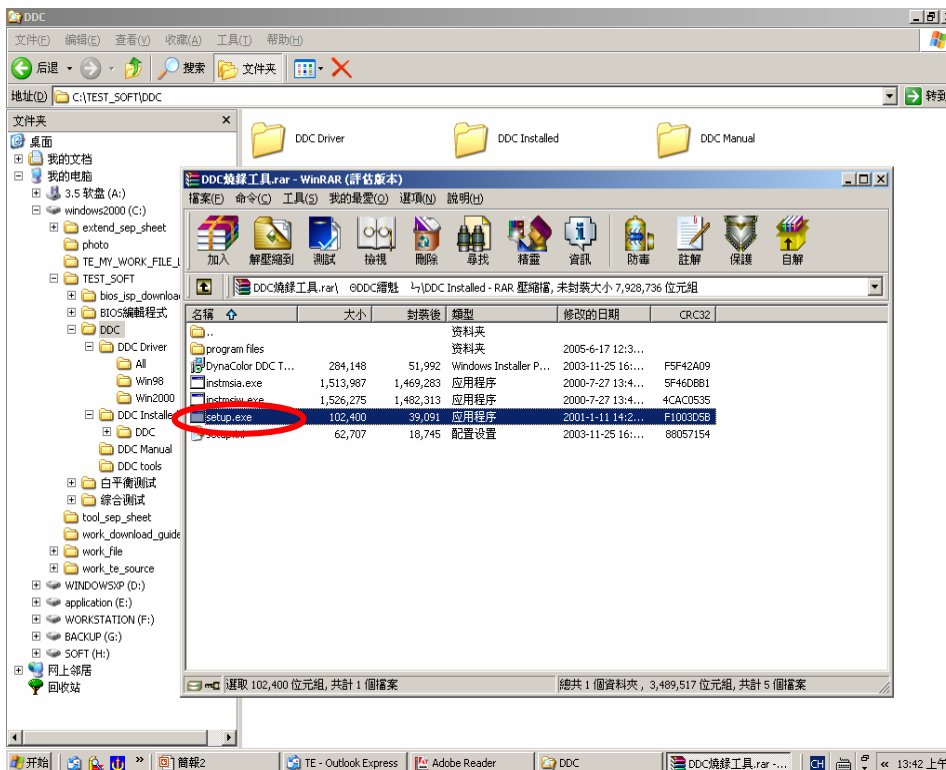

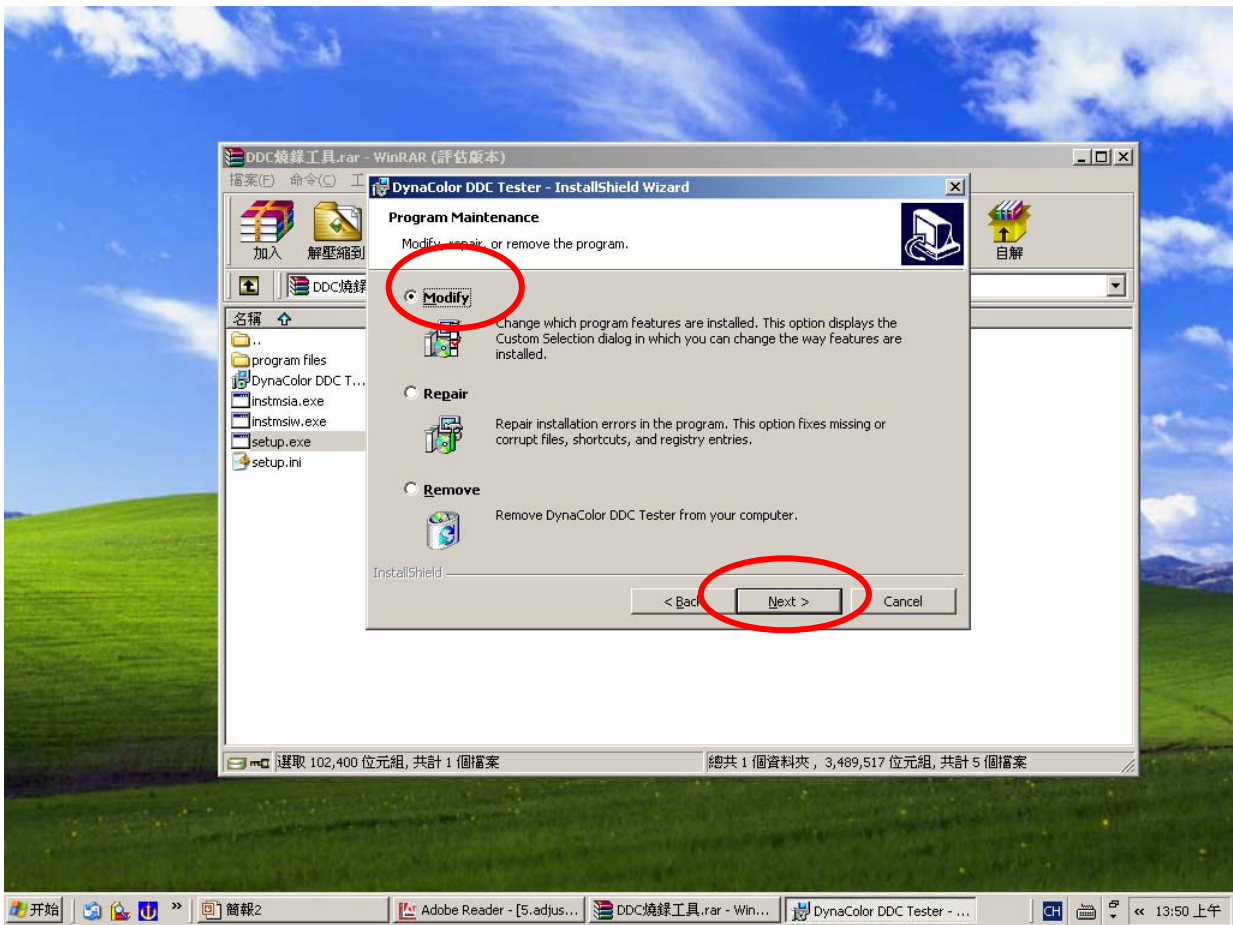
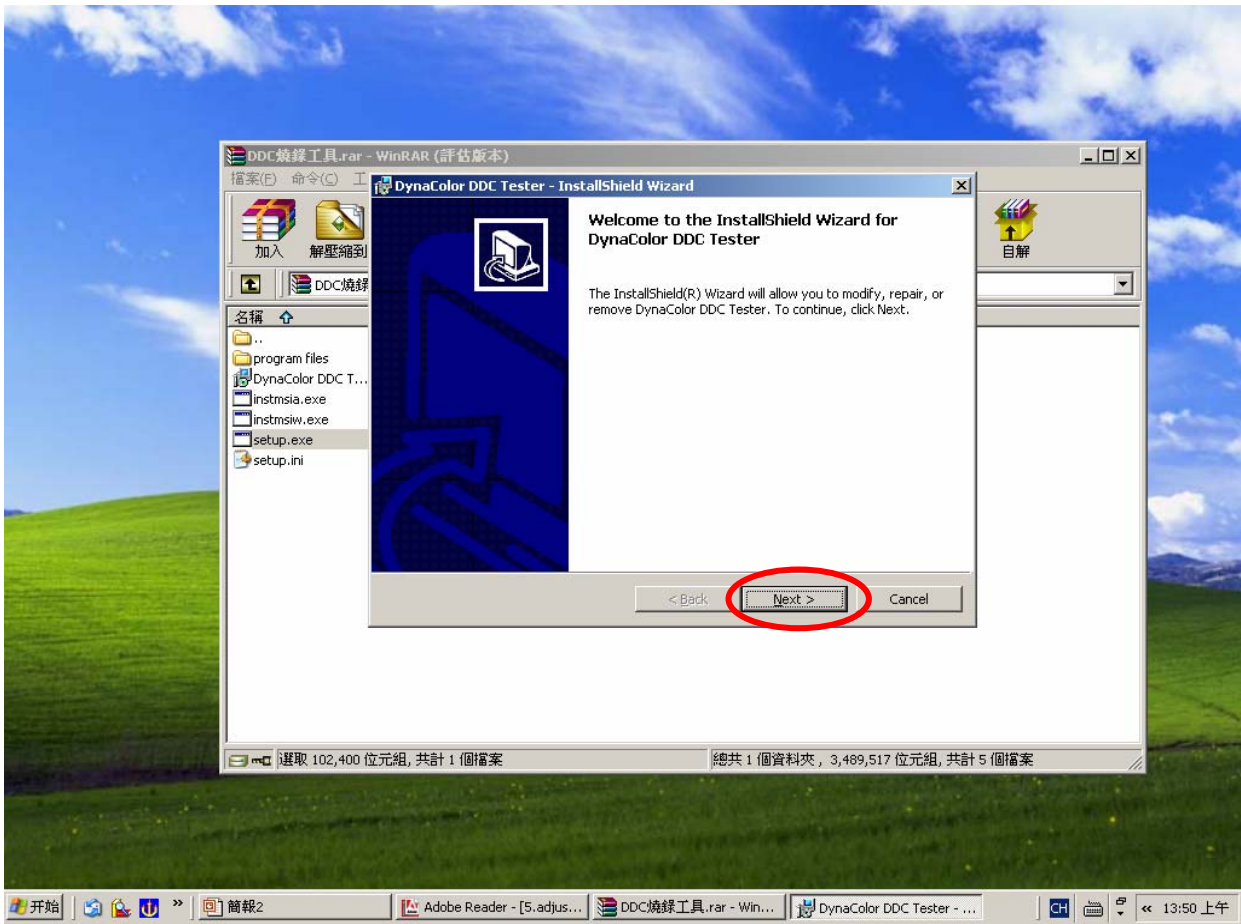

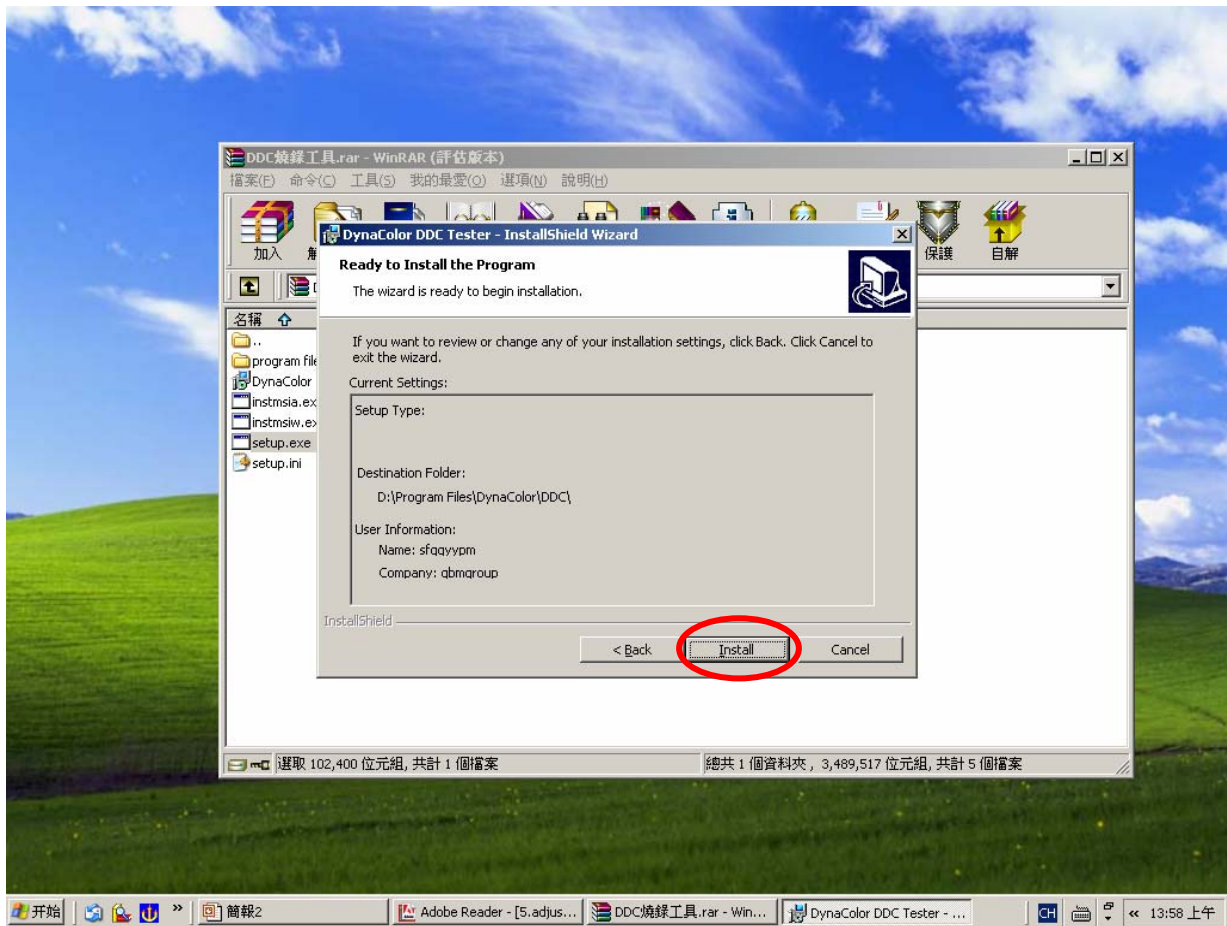
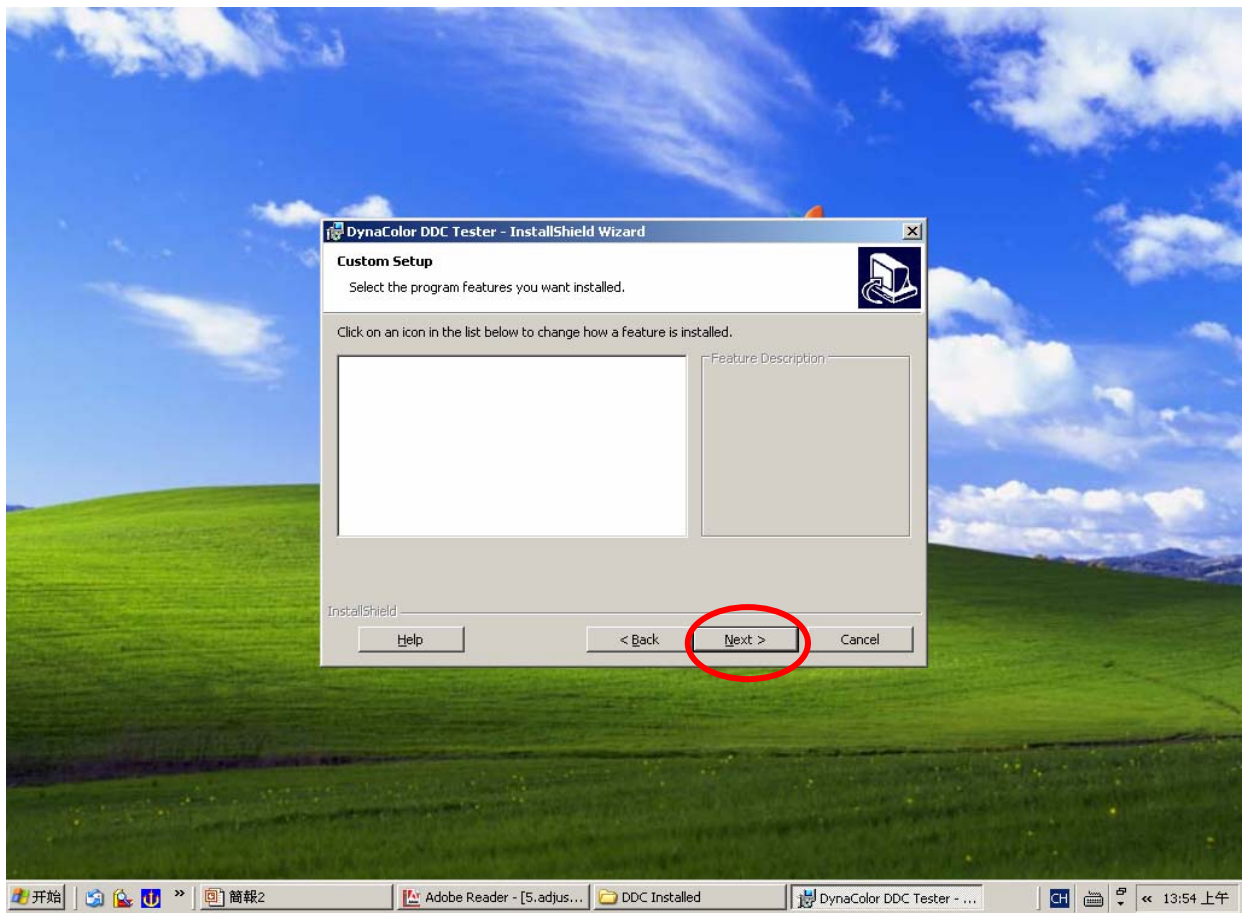

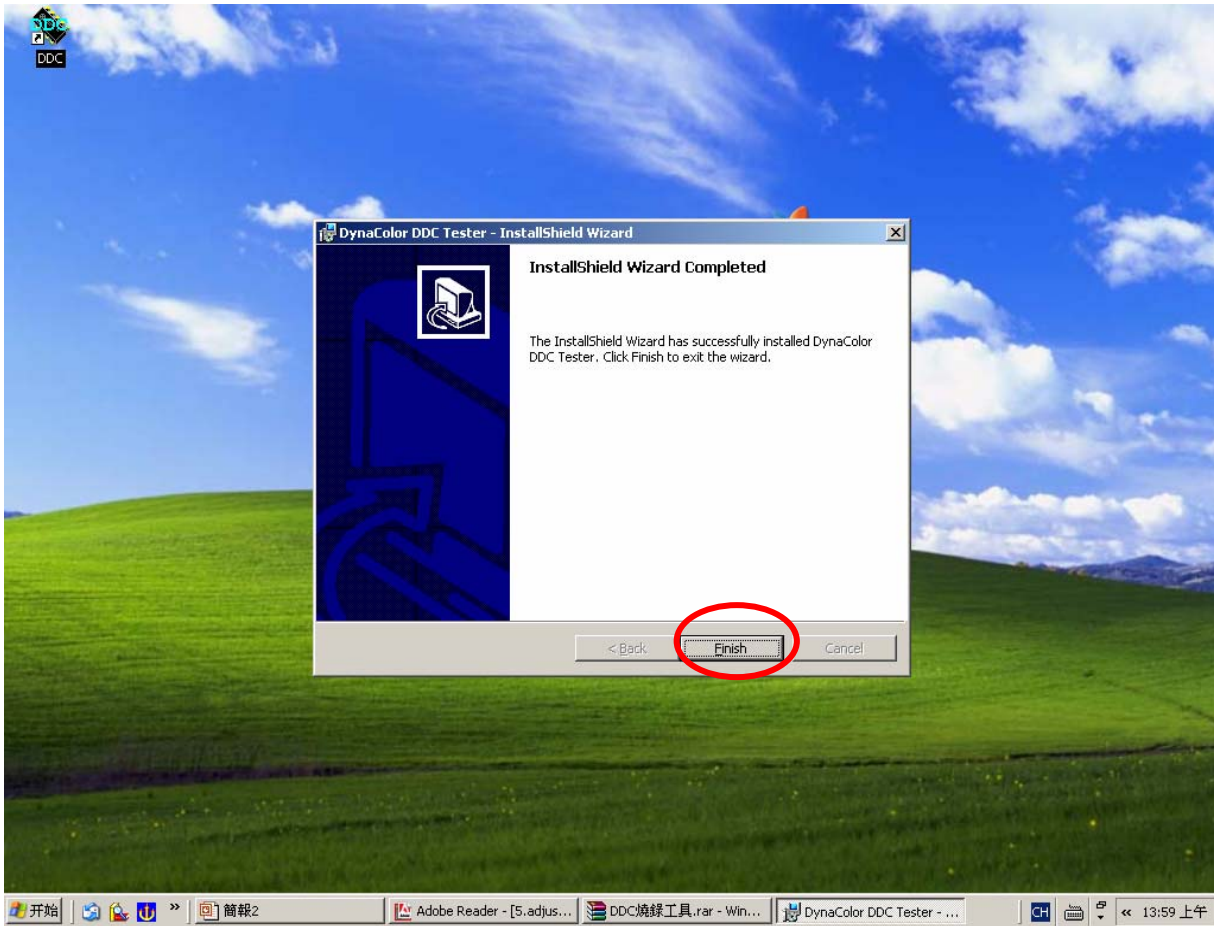

DDC Key In Procedure

Step 1 select and execute DDC Key In program (winDDC.exe icon on desktop)

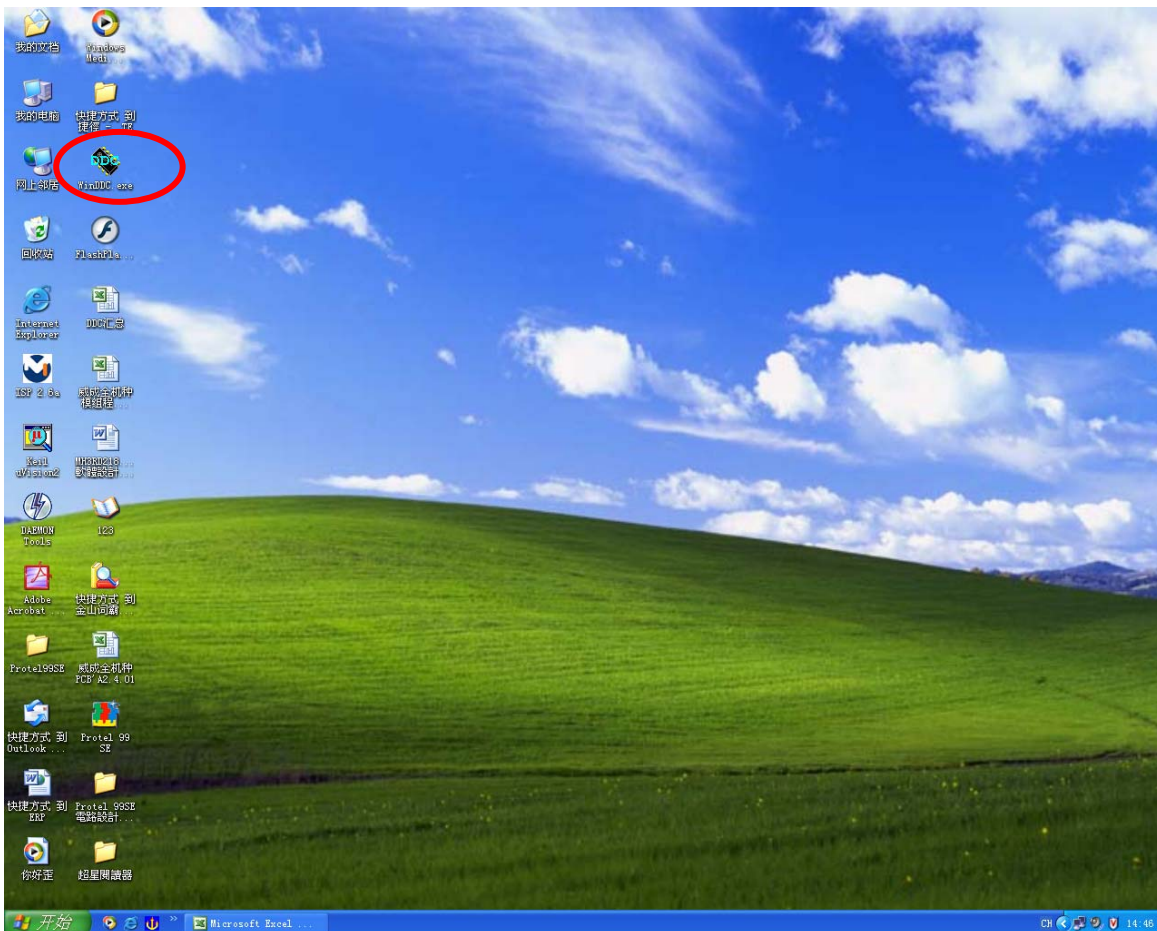

Step 2 Load DDC source file

Step2.1 Choose "File" menu, click "Model Edit" and enter "model edit" dialog box

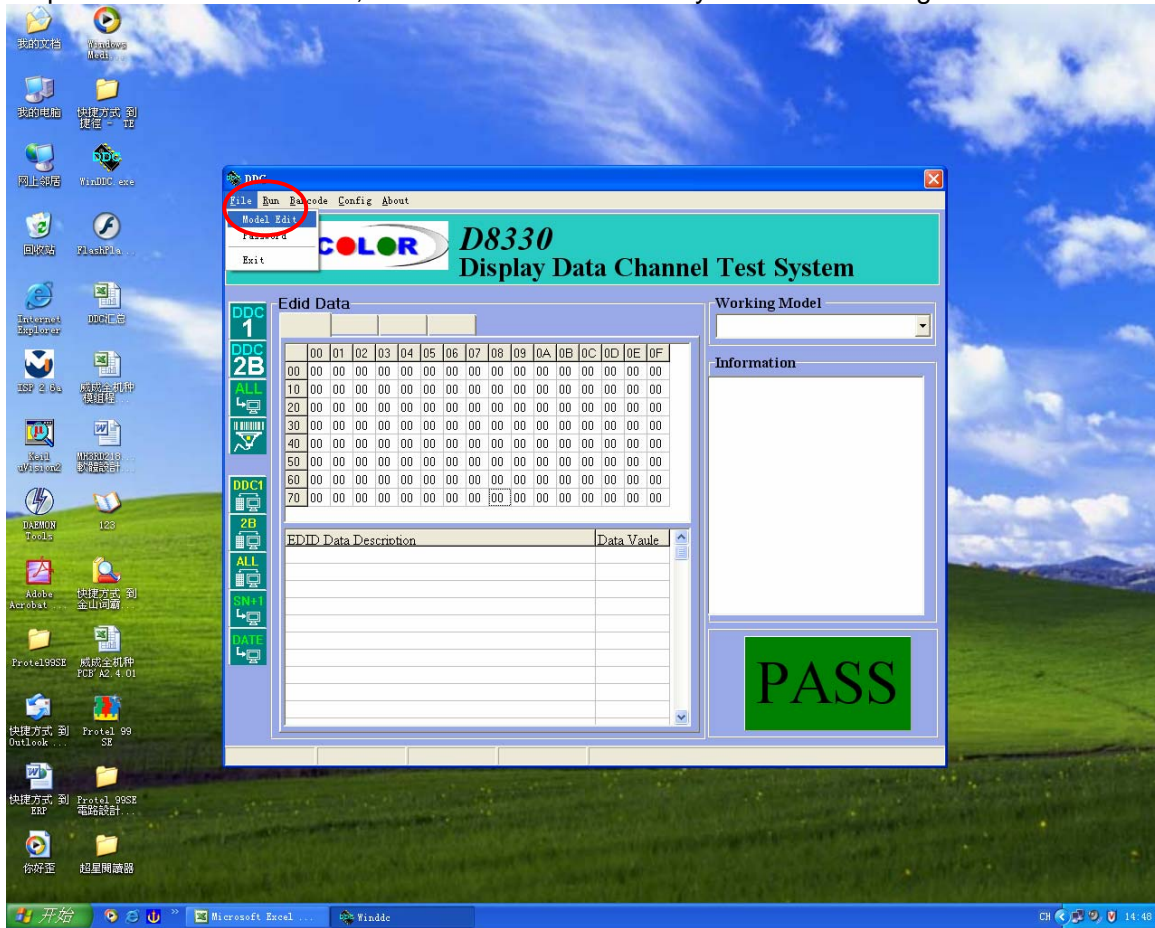

Step2.2 Press "Brower" button , set current DDC_LOAD_FILE working path

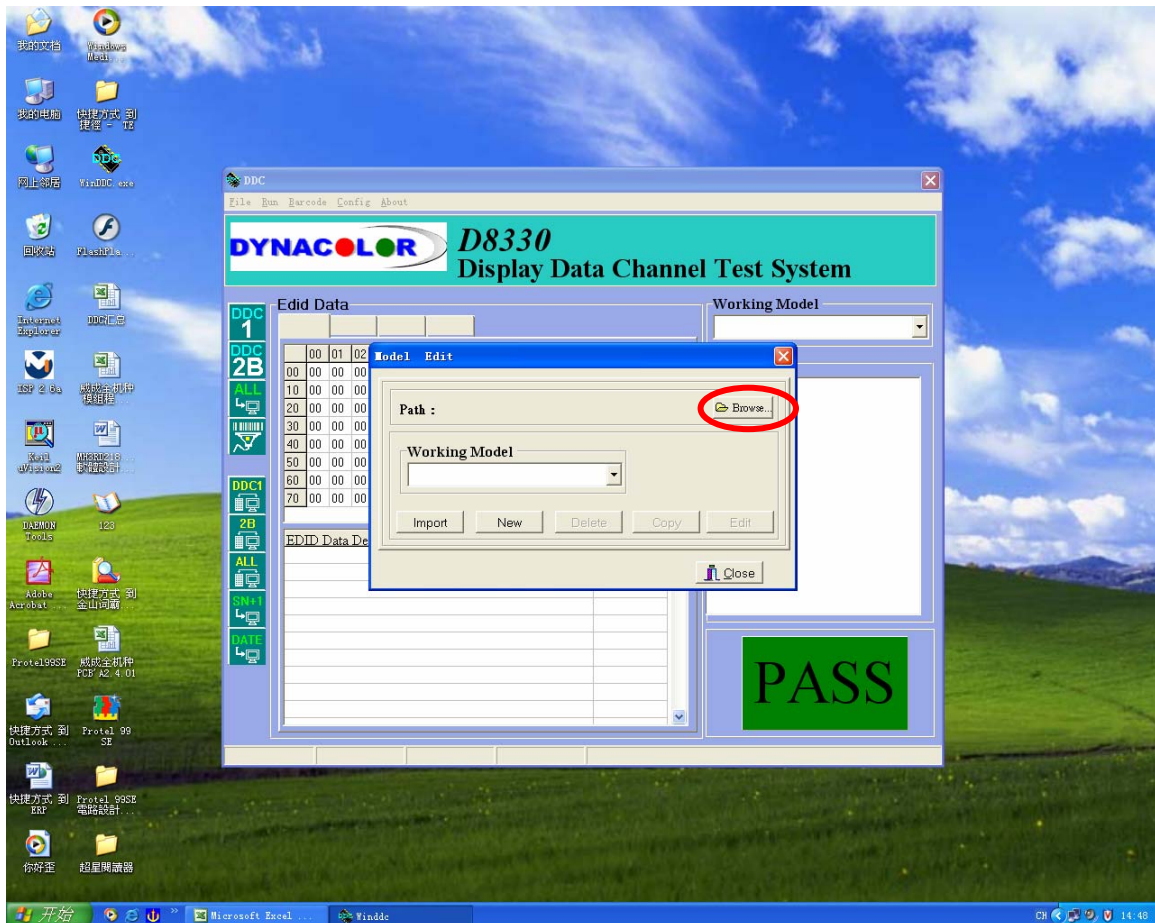

Step2.3 click “working Model”, select Model in list box

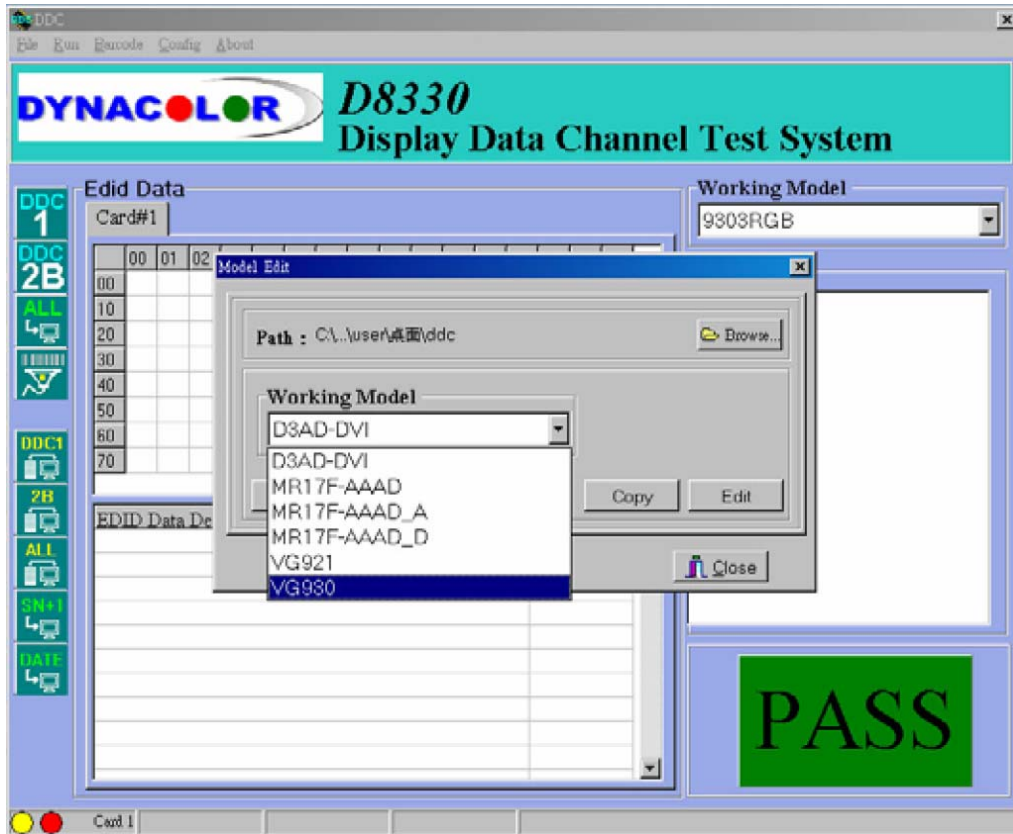

Step2.4 Return to main windows of “ WinDDC.exe”. And choose DDC file in “work Model” down-list box

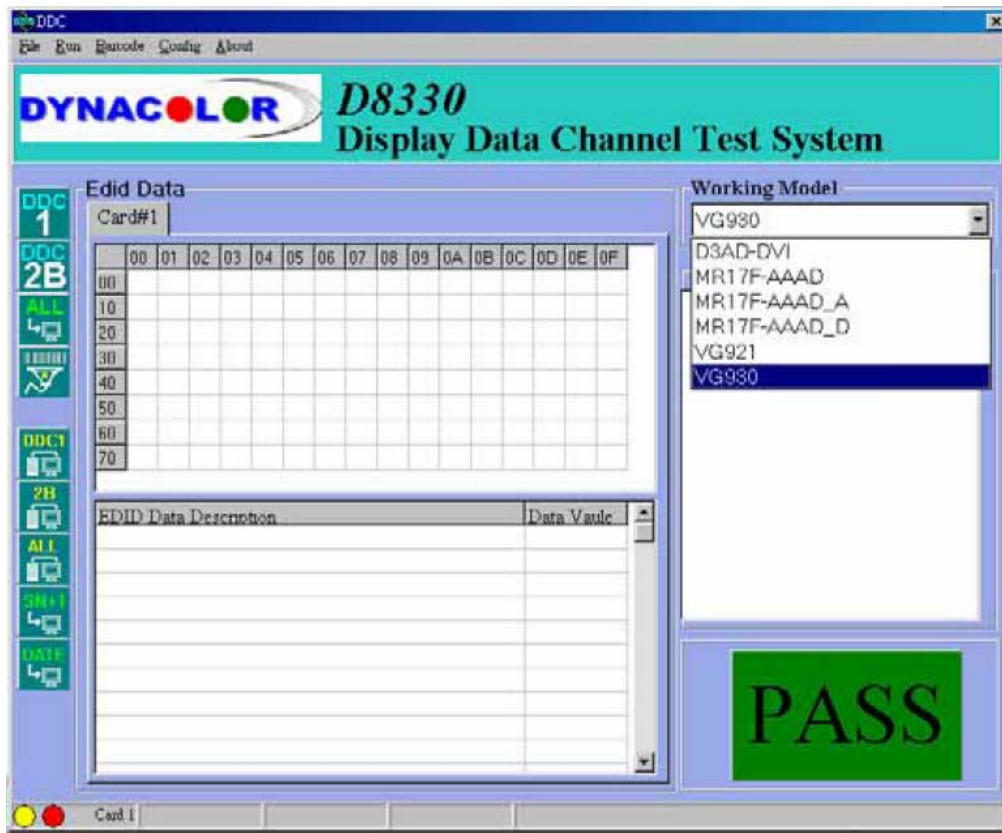

Step3 Double click the “input barcode” icon at the toolbar, Key in the serial number or Use Barcode Scanner to scan the barcode of the monitor. and press the “enter” key .

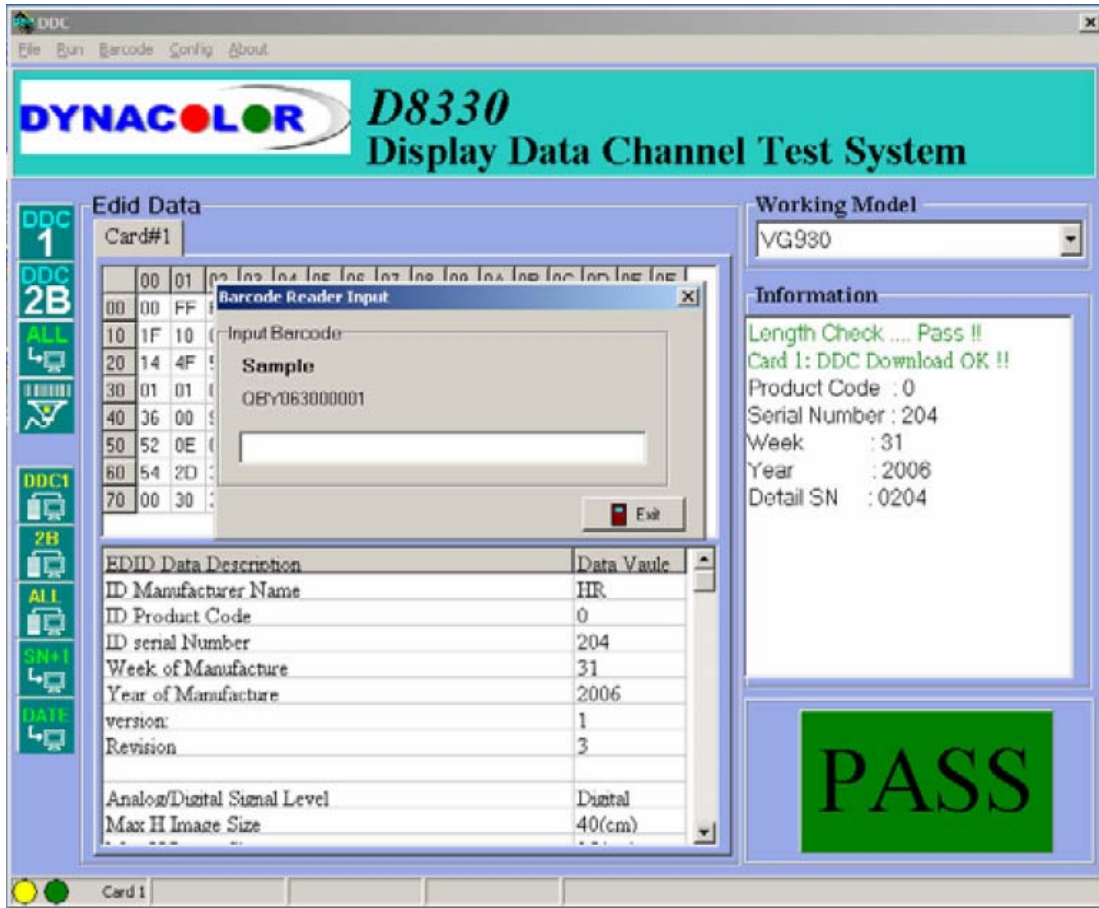

Step 4 The successful picture is as follows. The EDID data Description will appear the bottom of windows The EDID Data will appear the top of windows.

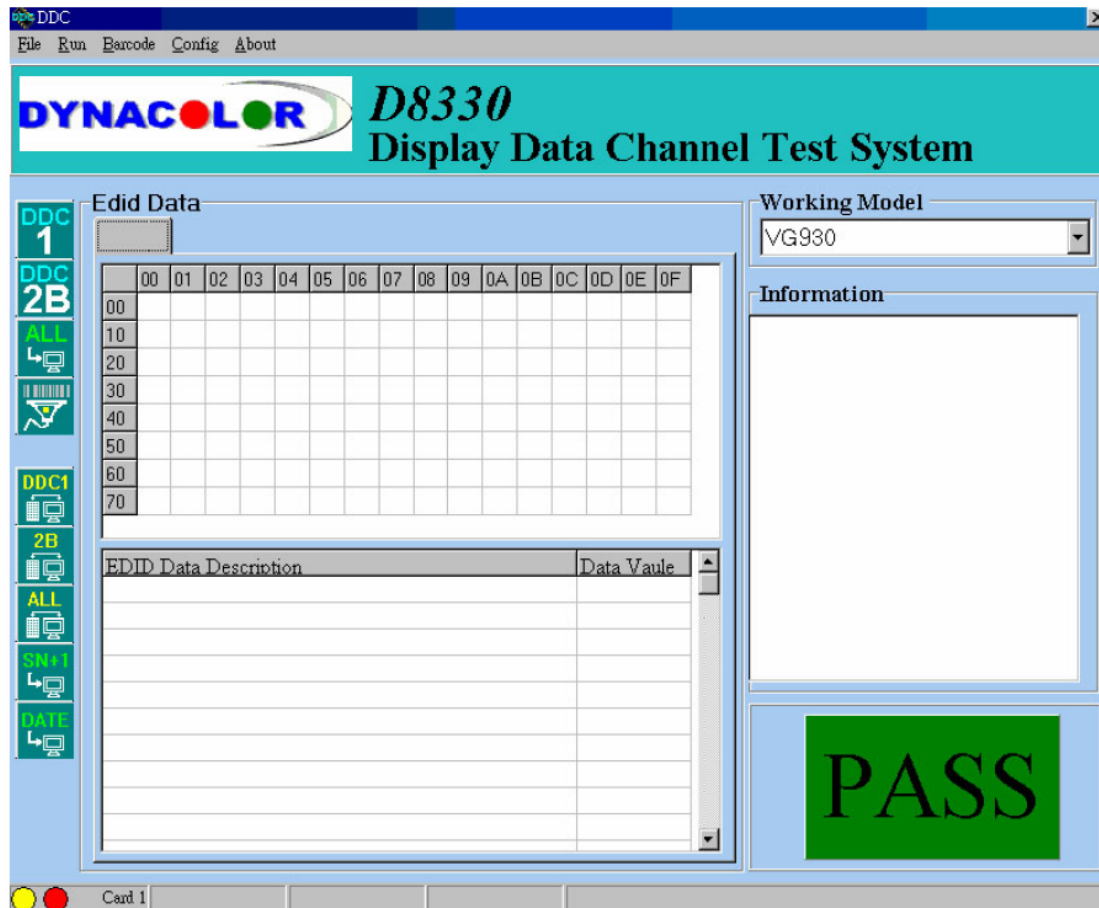

Step 5 Checking Methods

Step5.2 open up the “my computer” attribute dialog box, select the “hardware” option, open up “drive management”. Below the monitor catalog, uninstall the monitor.

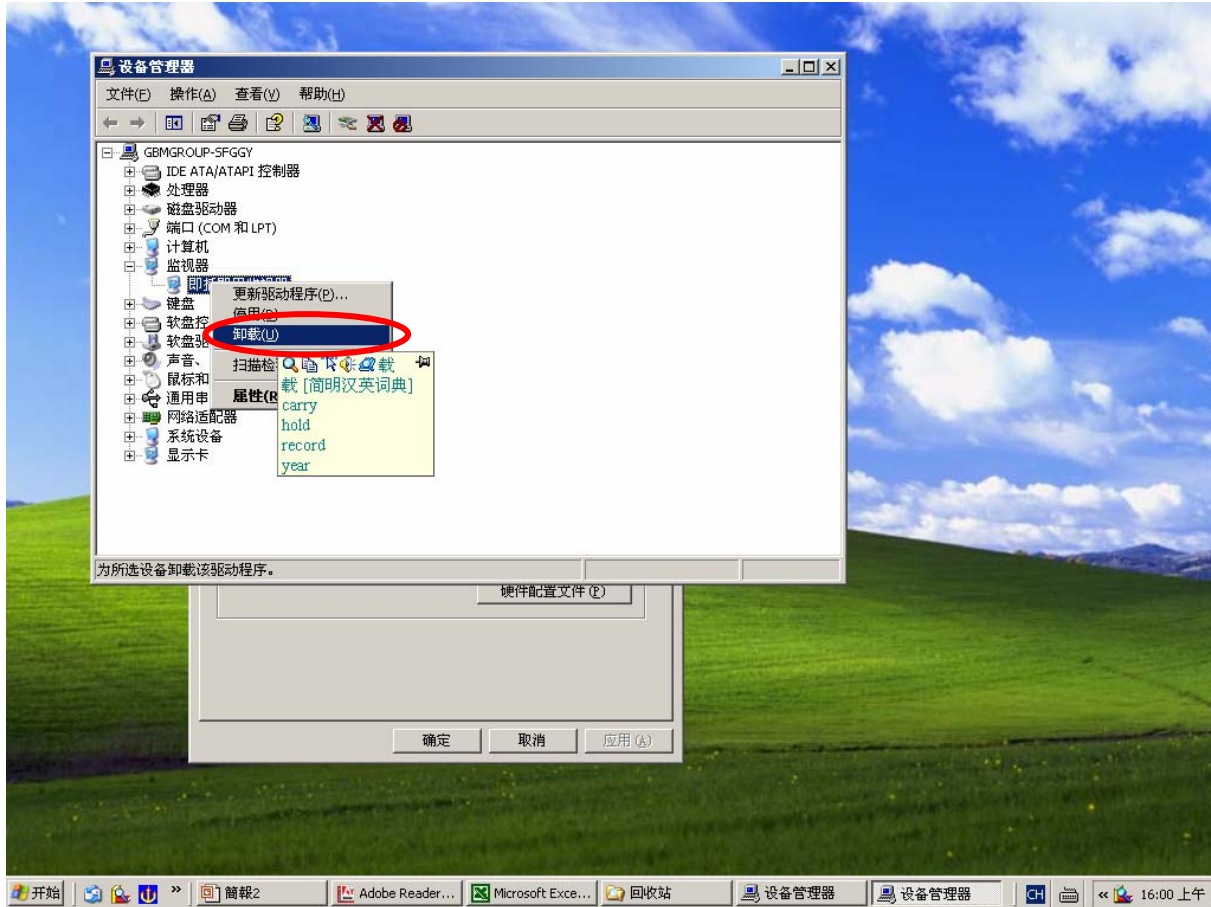

Step5.3 Scan the hardware change ,until system find the new monitor driver

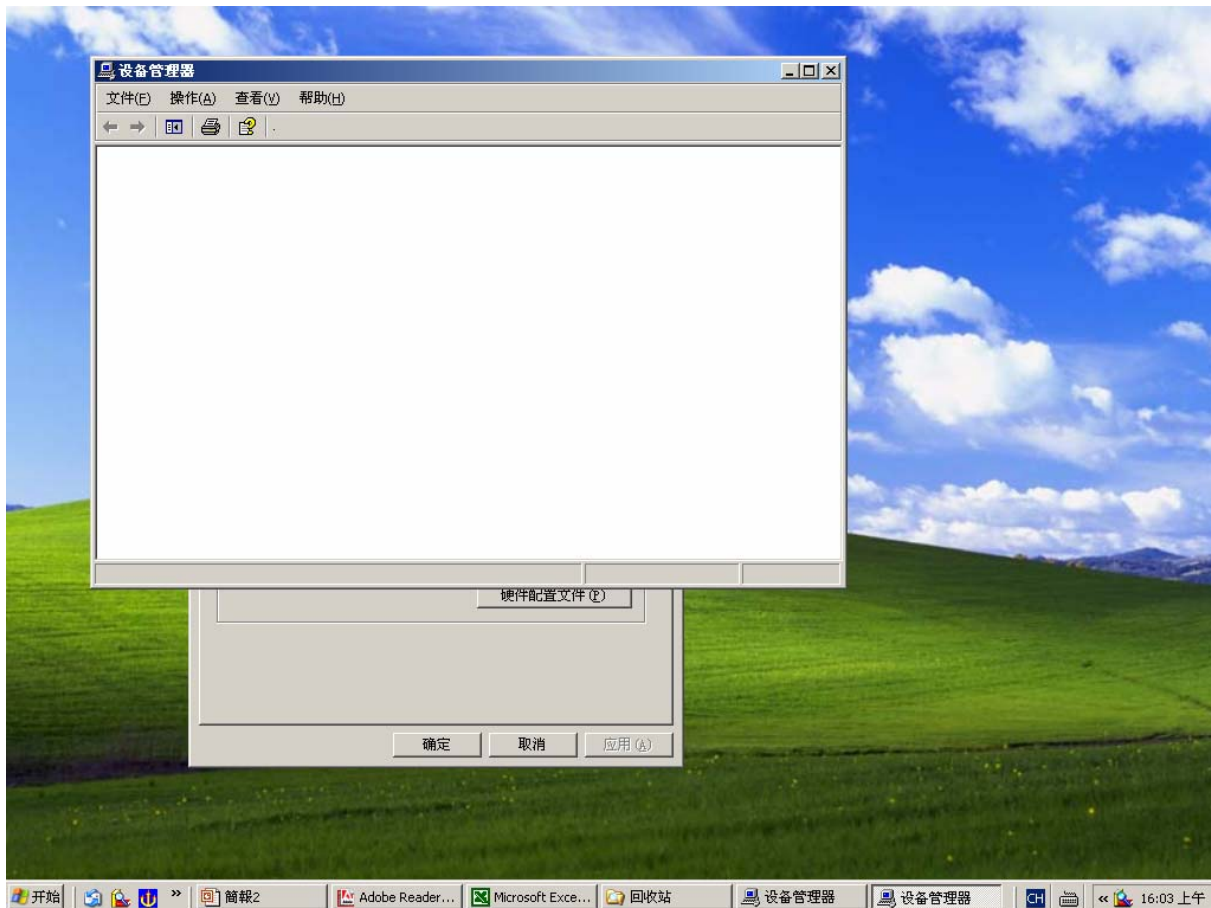

Step5.4 Select and click the “EDIDW2K.EXE “file, the EDID information will show on the screen

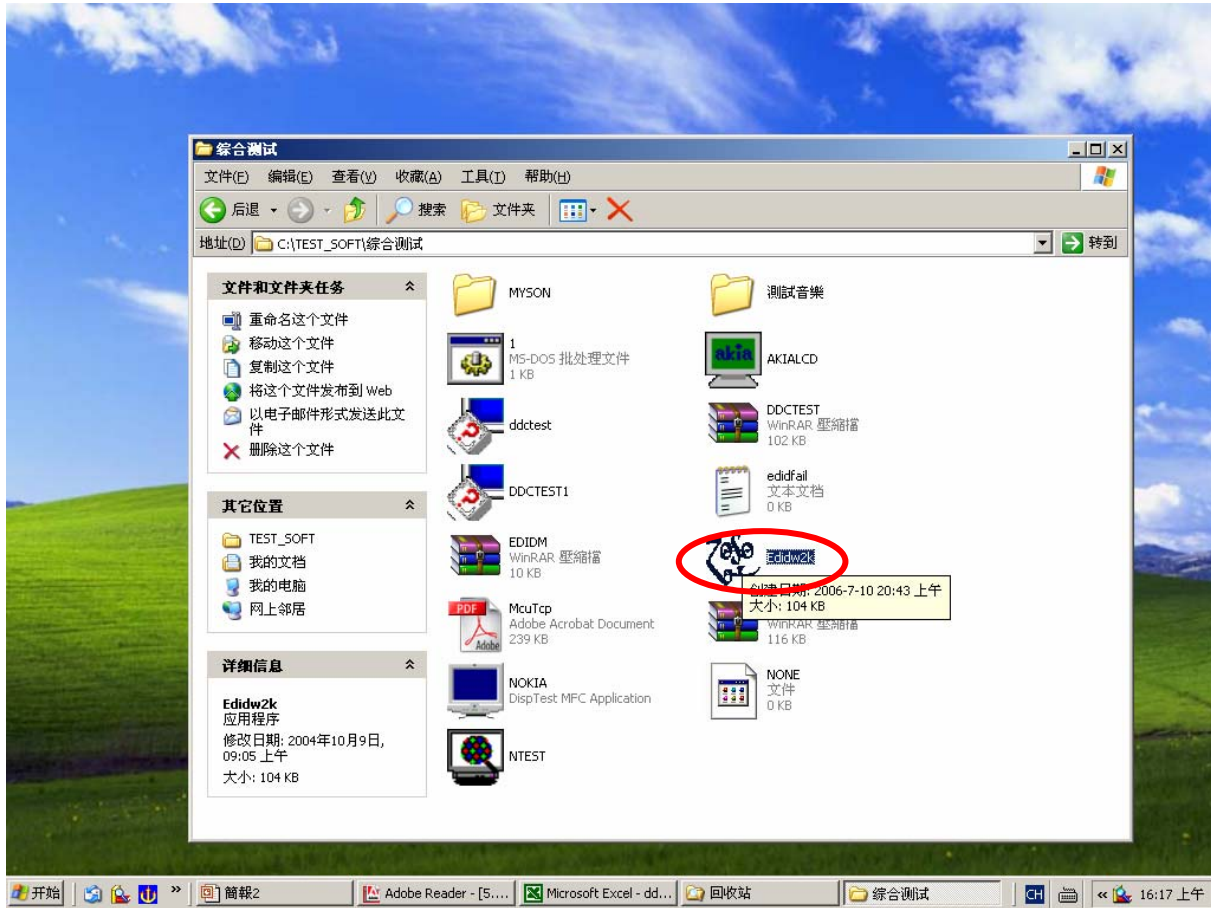

Step5.5 Check the DDC

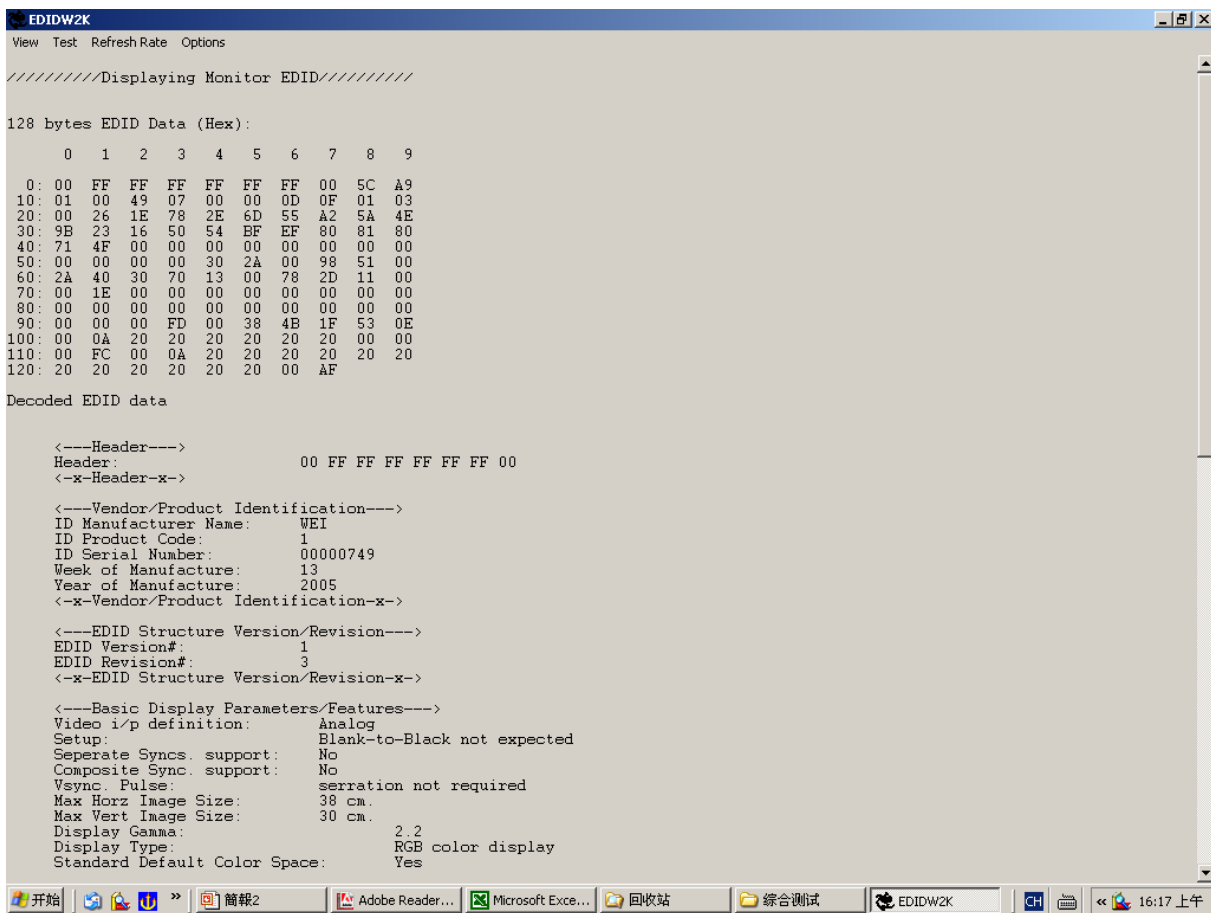

Packing For Shipping And Disassembly Procedure



Disassembly Procedure

1. (Take down the cover of bracket)



2. (4PCS) (Take down fixed screws on hinge)

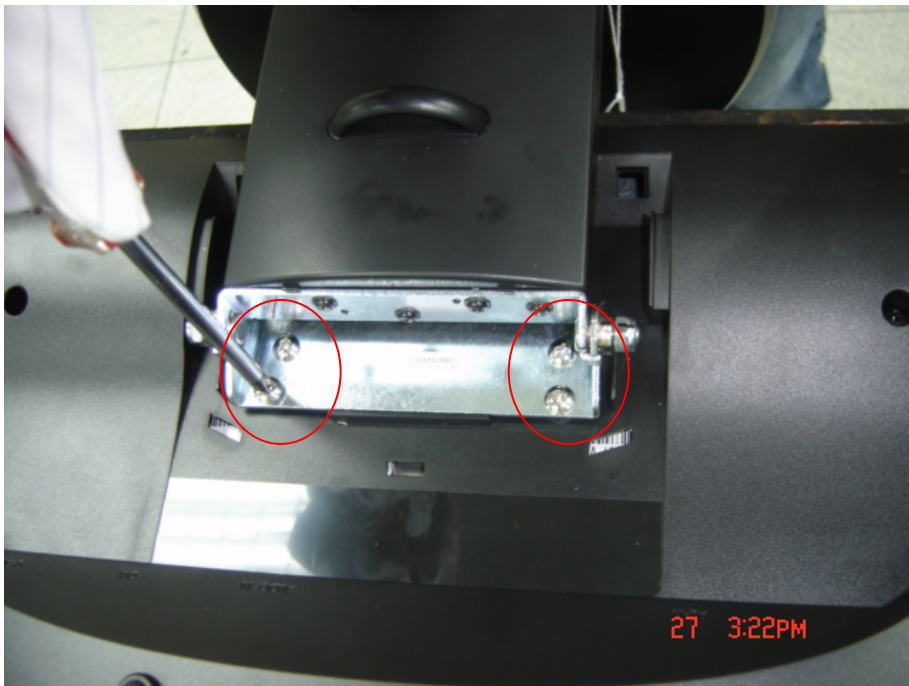

3 (3PCS) (Take down the rear cover screws)



4. (Take apart the rear cover)

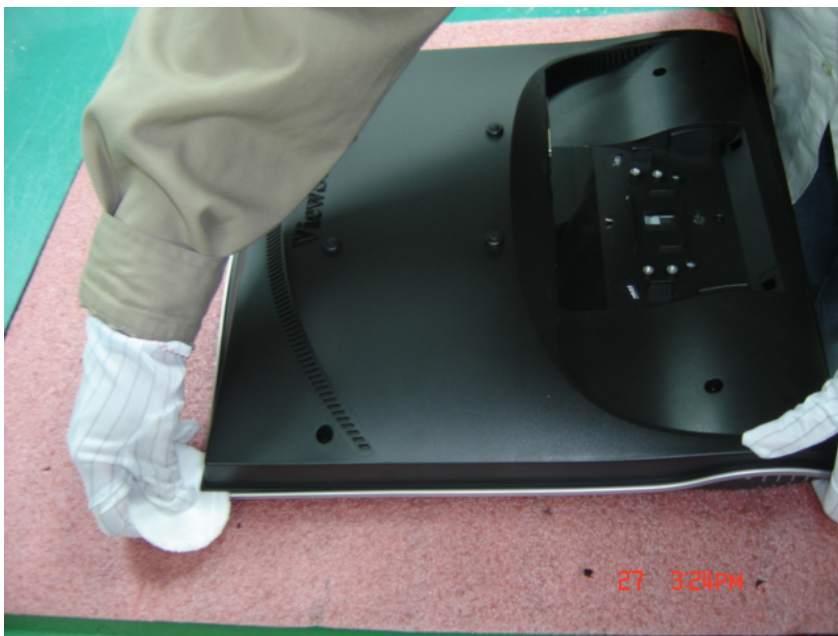

5. (Take down the speaker for right & left)

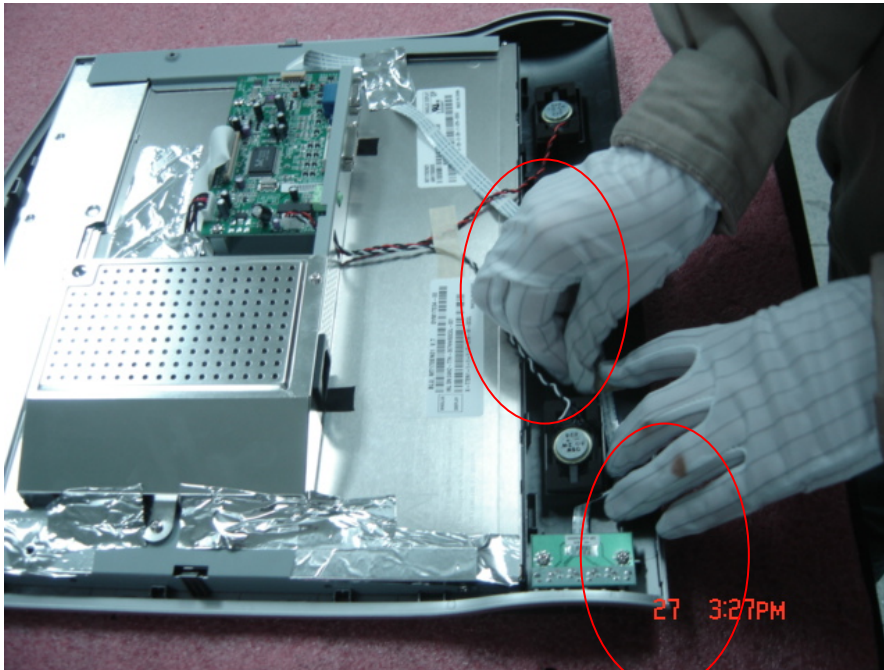

6. (Take down fixed wire of speaker; Unplug the wire of speaker)

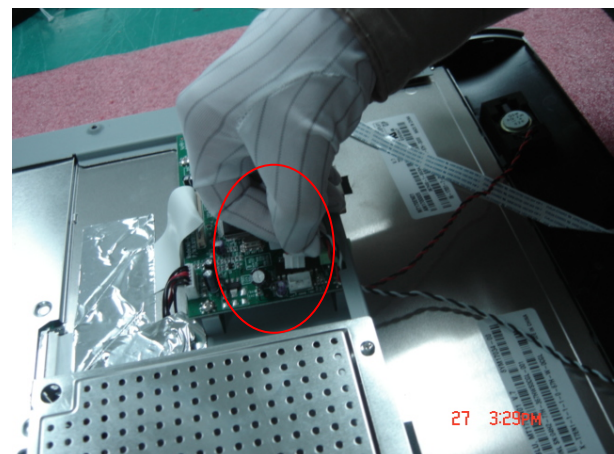
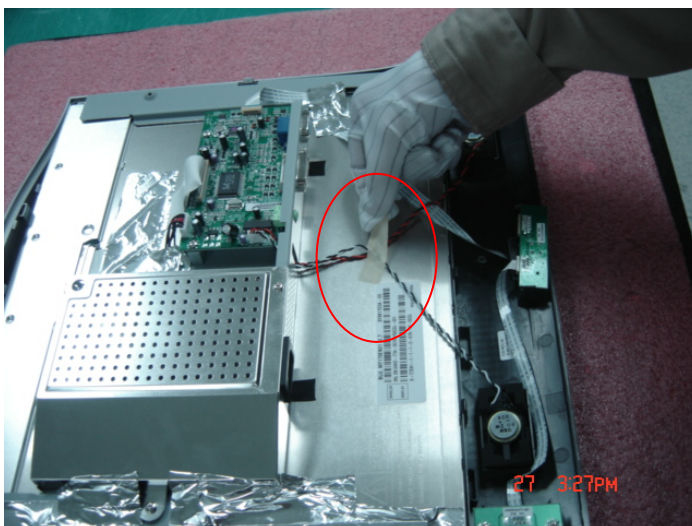

7. (Take down fixed ALT of wire on key-board; then, Unplug wire of main board)



8. (Take down the screws on key-board)



9. (Take down the ALT of wire on lamp)

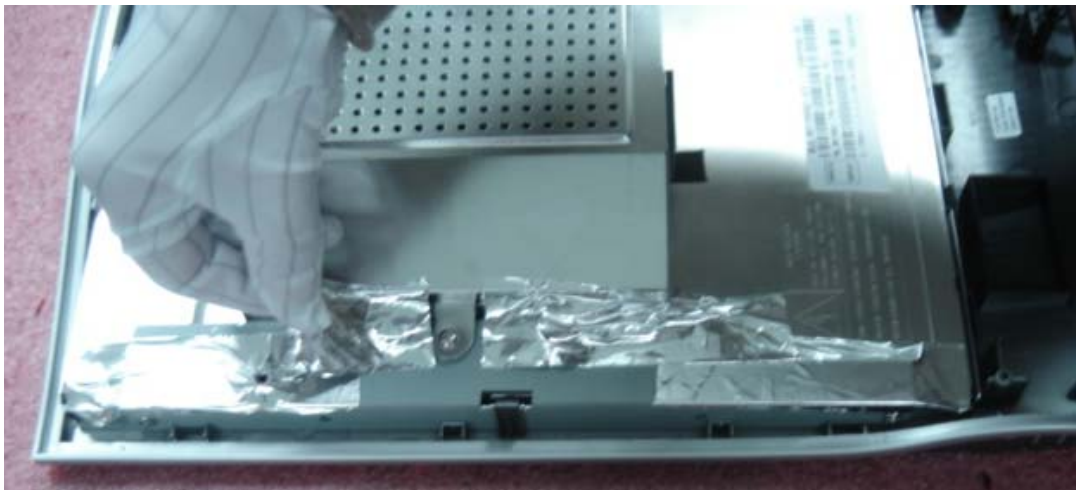

10.(Take down the screws on screen cover)

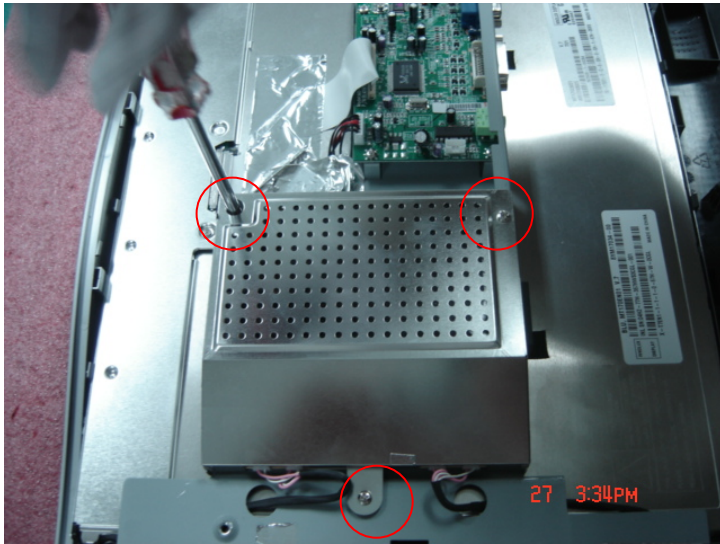

11. (Take down the ALT of wire with main board & power board)

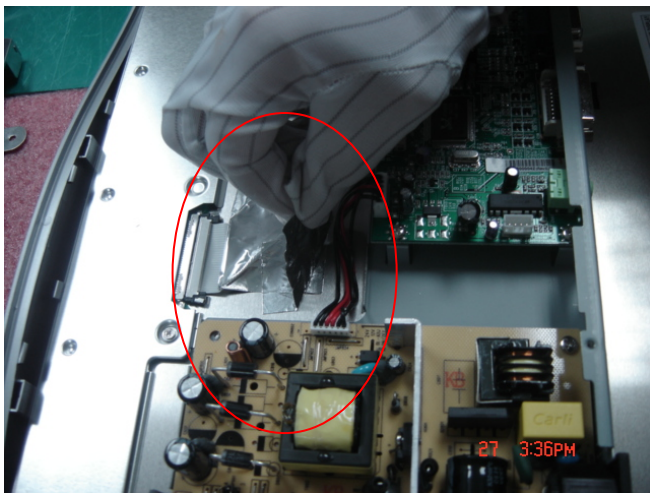

12. (Take down fixed the FFC ALT)



(Take down the FFC)

13 (Take down the FFC)

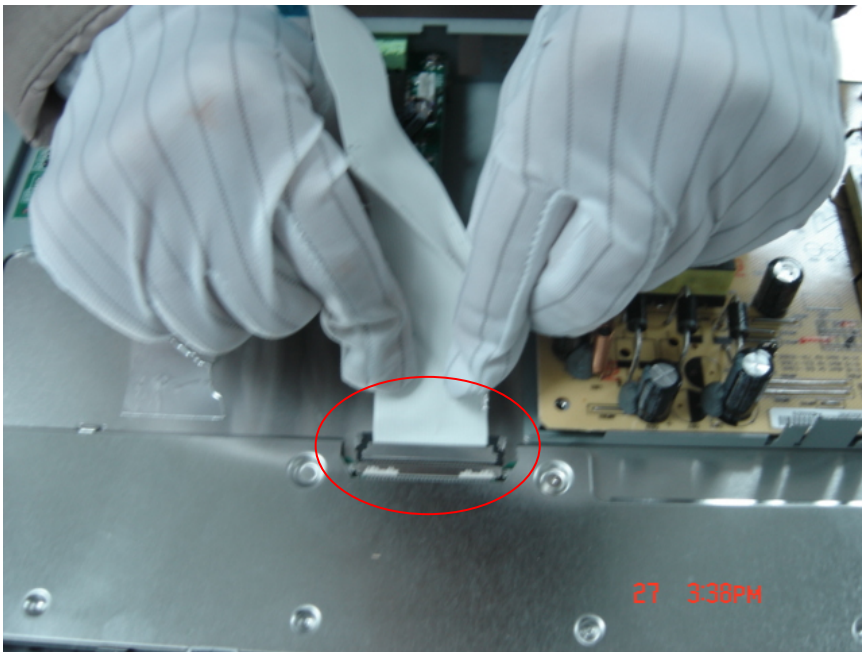
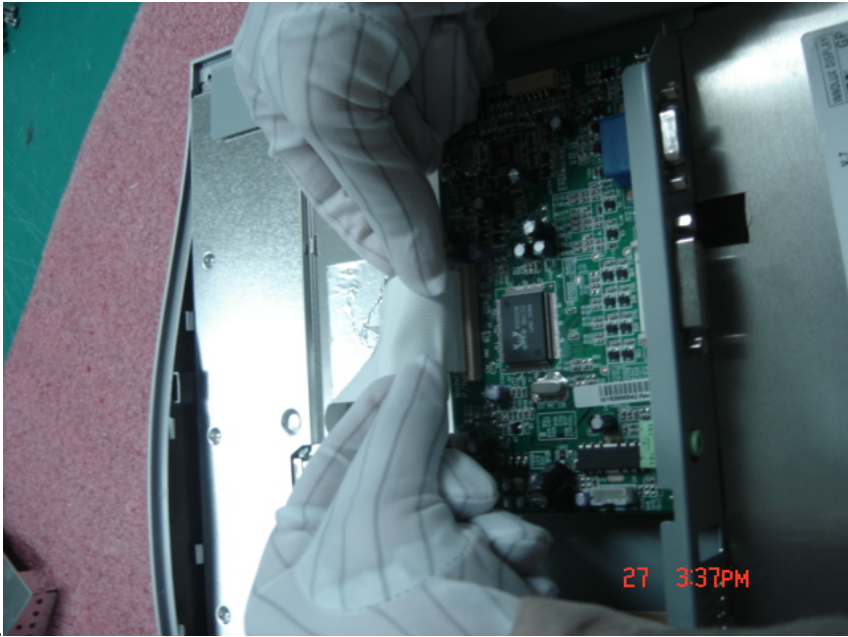

14. (Unplug the linked wire with main board & lamp)

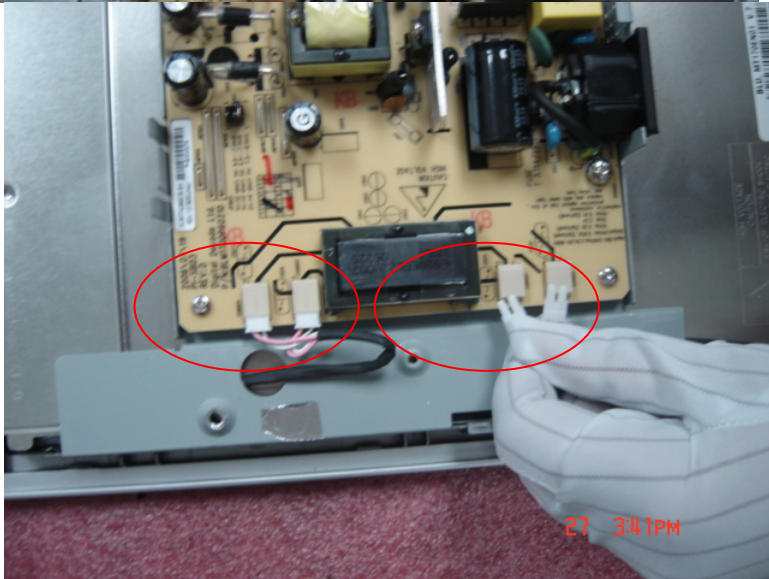
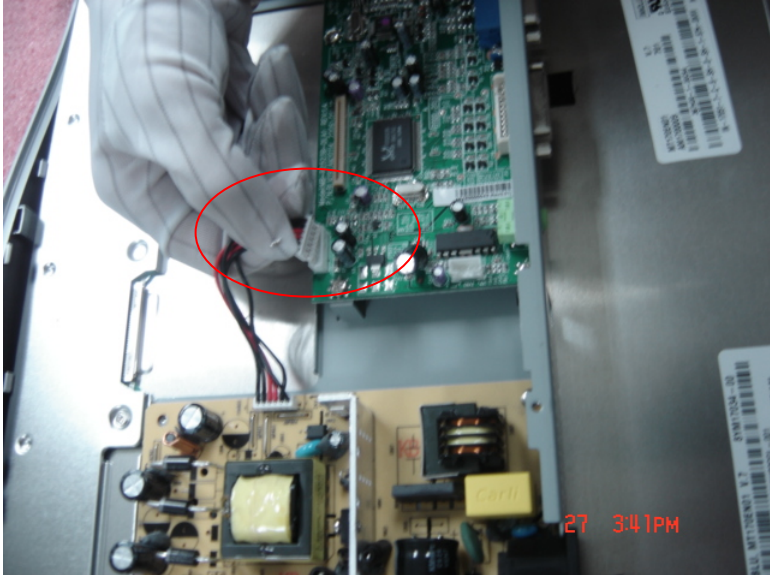

15. Take down the screws of power board & then take down the power board)

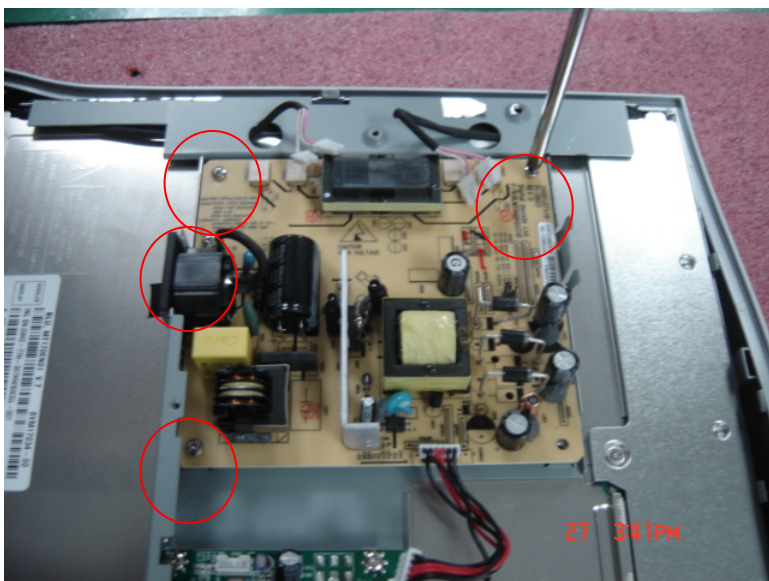

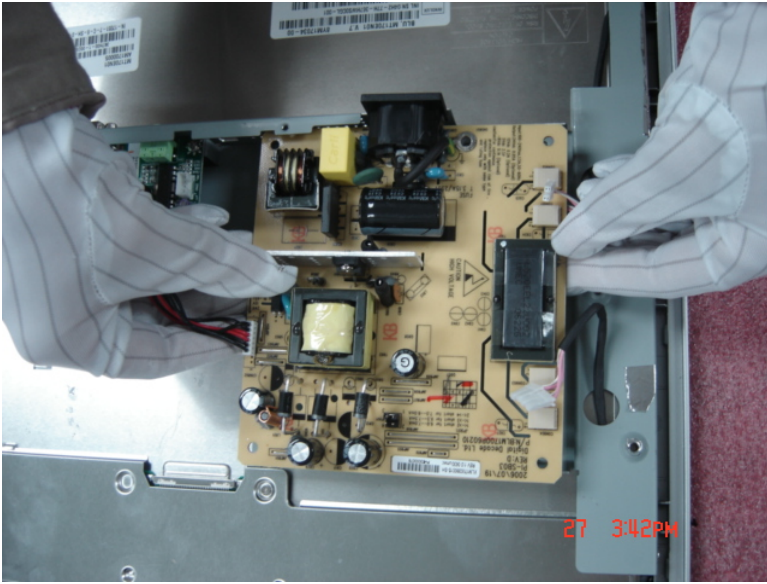

16. (Take down the screws of main board & then take down the main board)



17. Tear down the around hook outside, and then take down the Bezel.



18. Take down the main hob around the sides of screws, and then take down the main hob.





6. Troubleshooting Flow Chart

Main Procedure

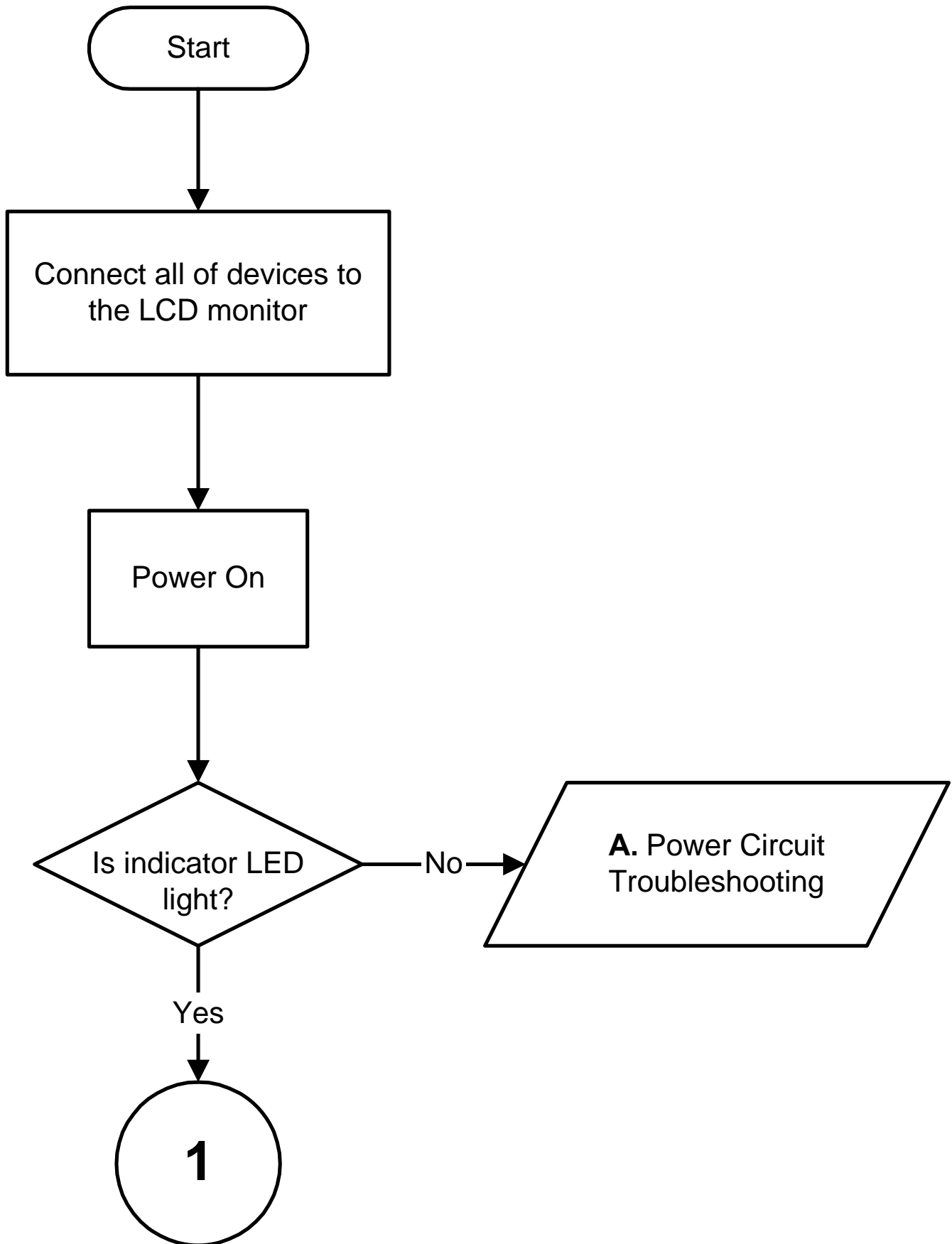

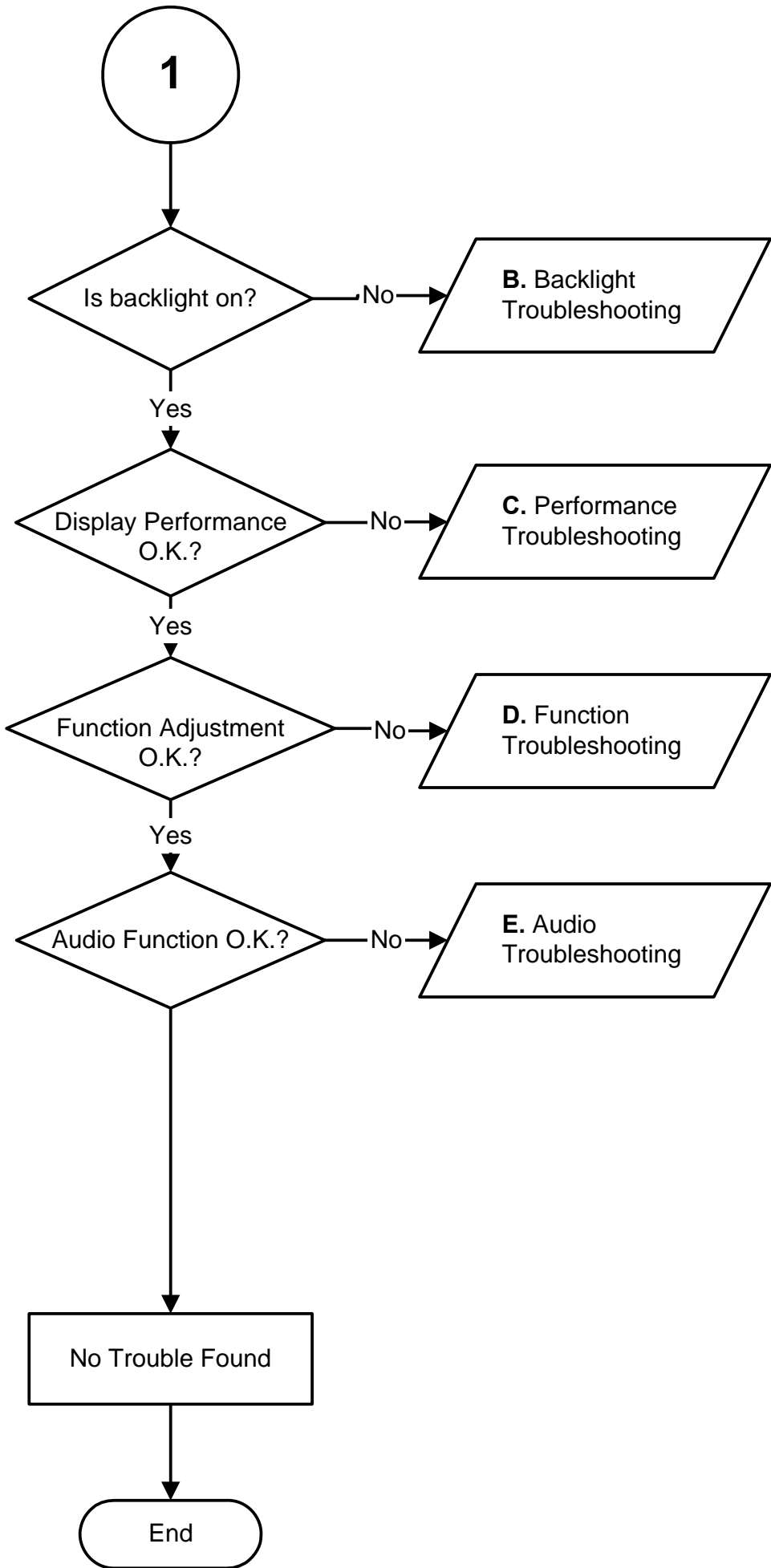

A. Power Circuit Troubleshooting

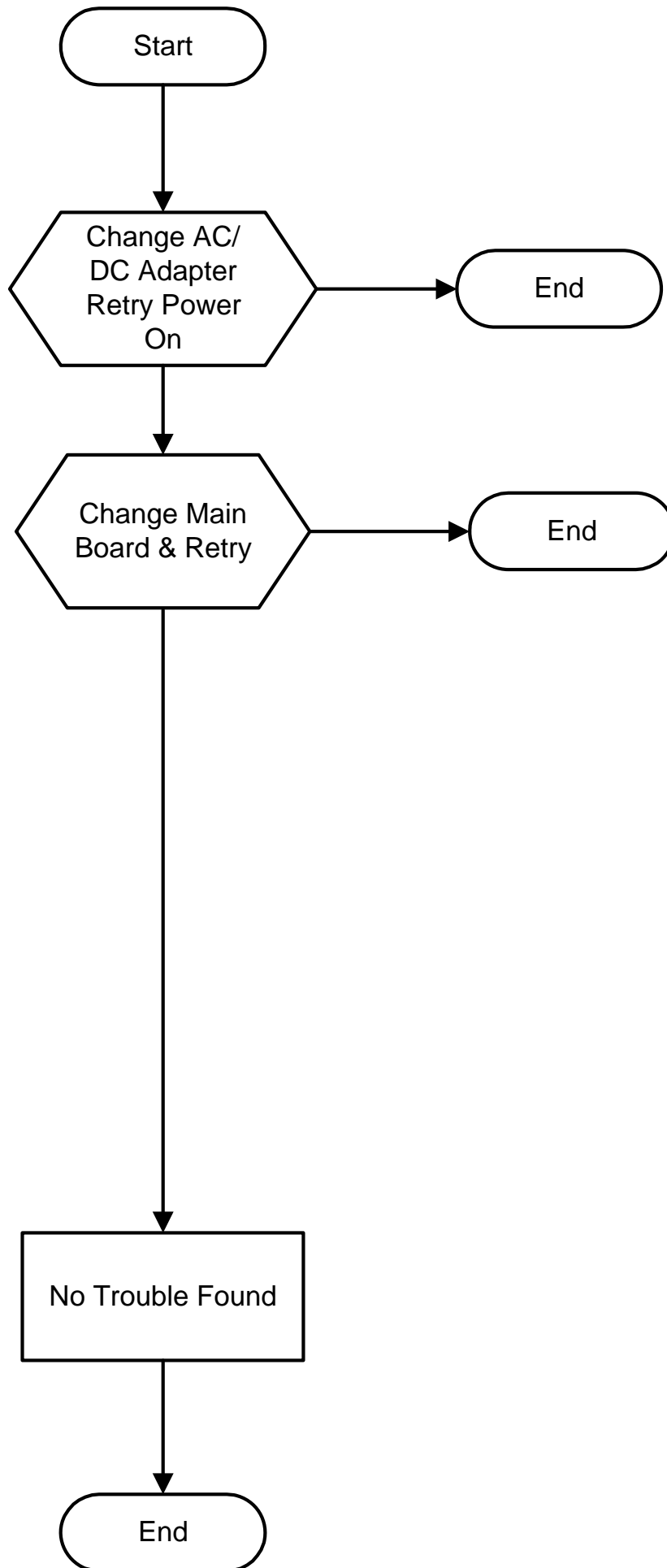

B. Backlight Troubleshooting

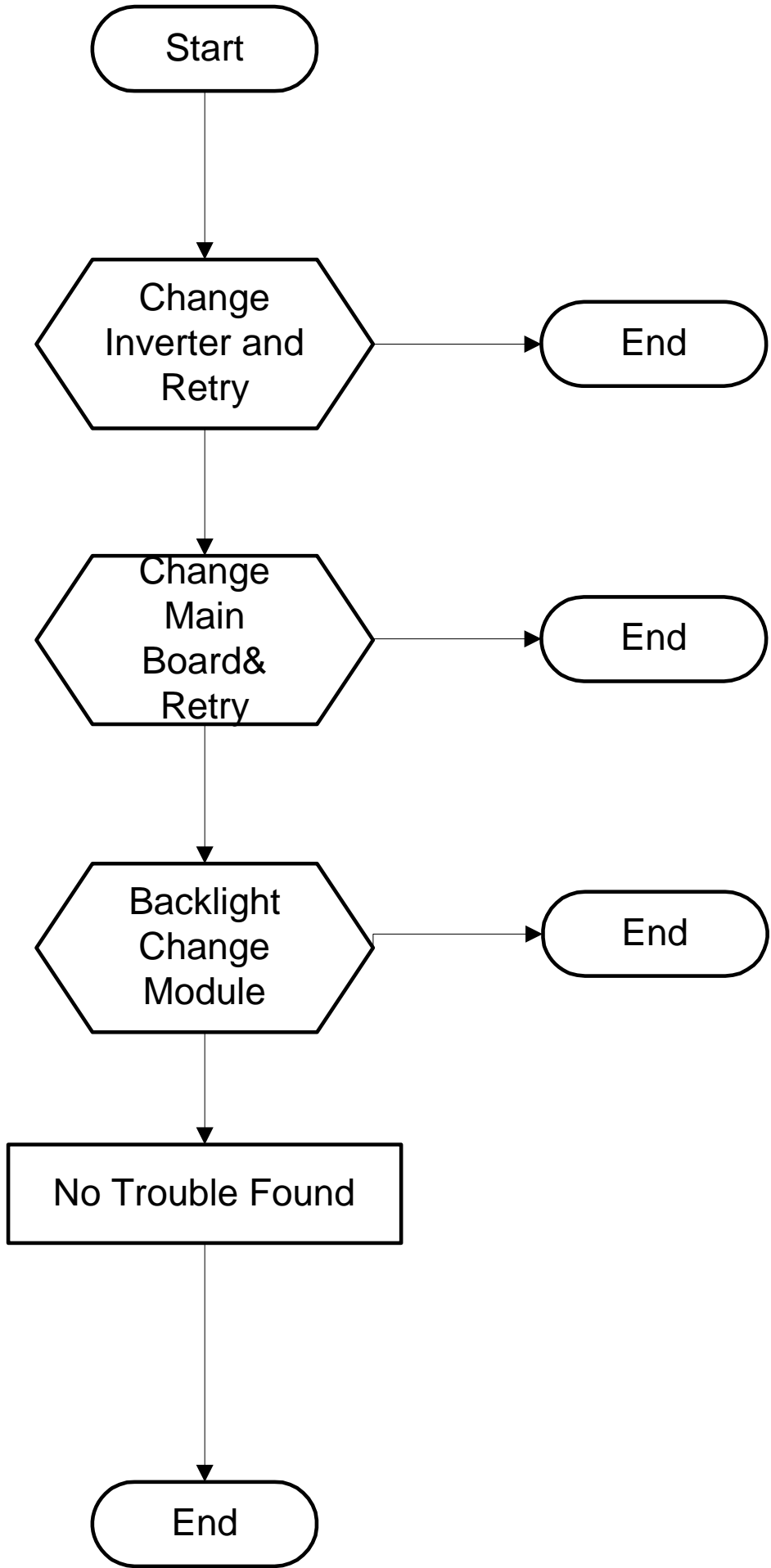

C. Performance Troubleshooting

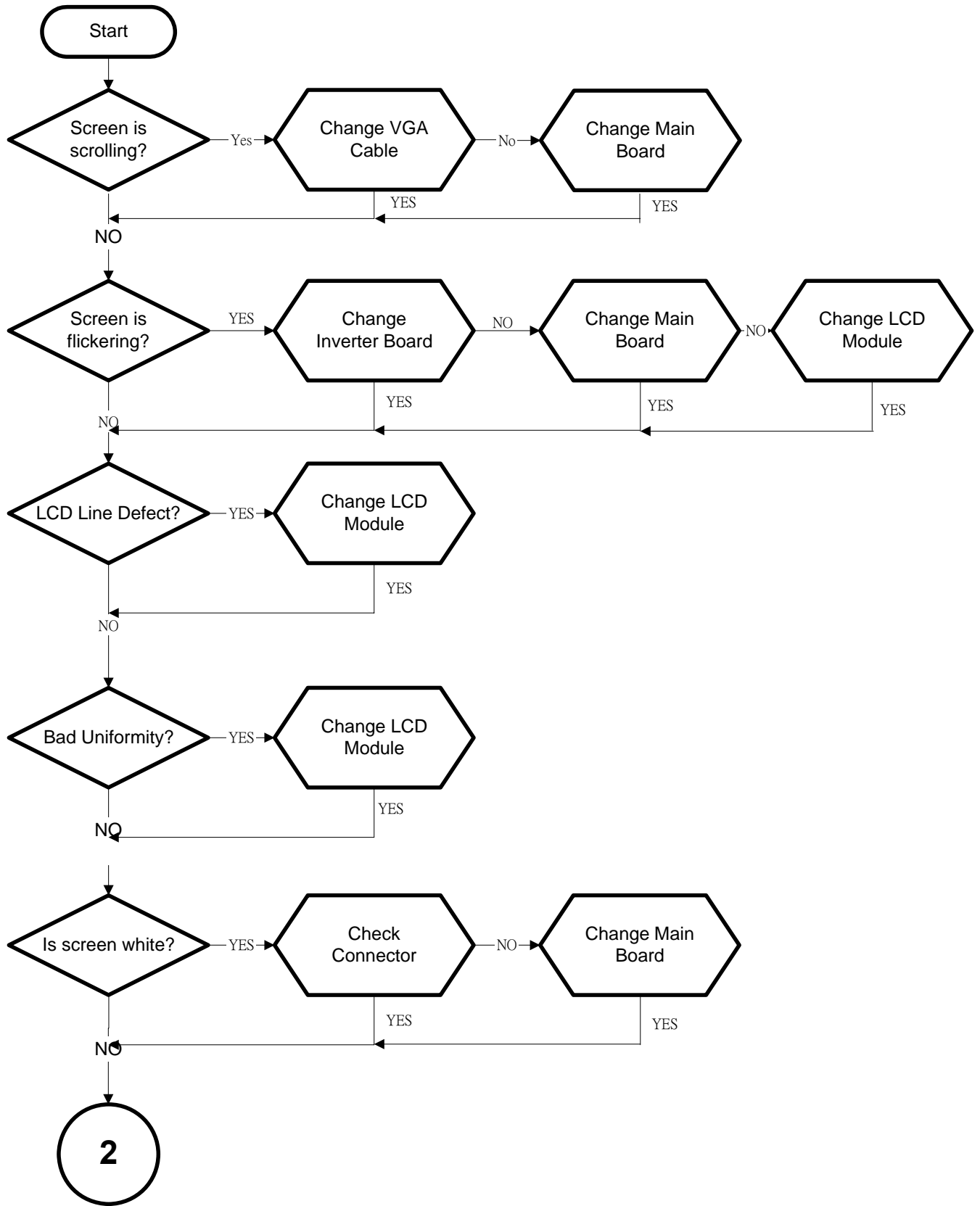

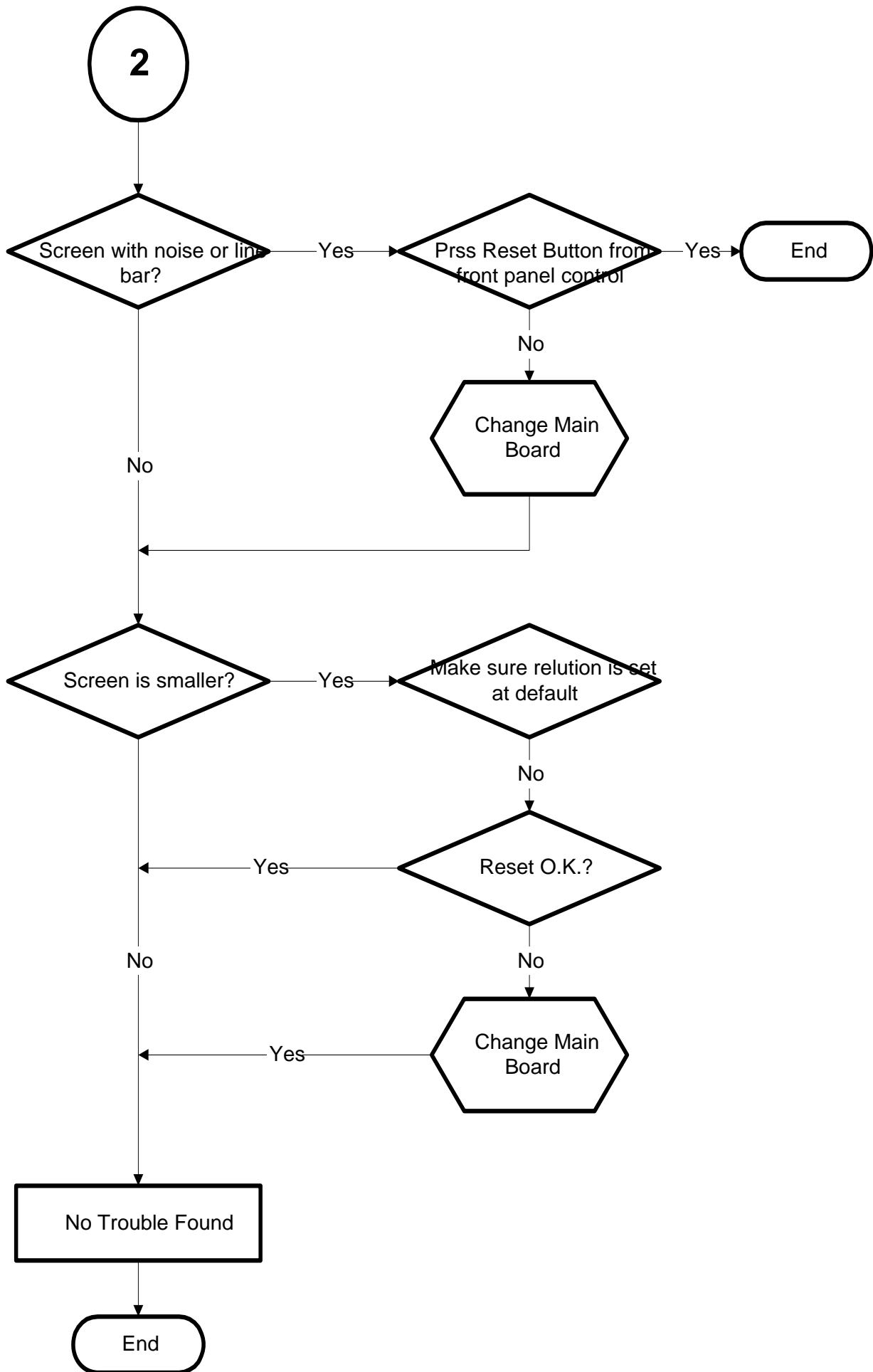

D. Function Troubleshooting

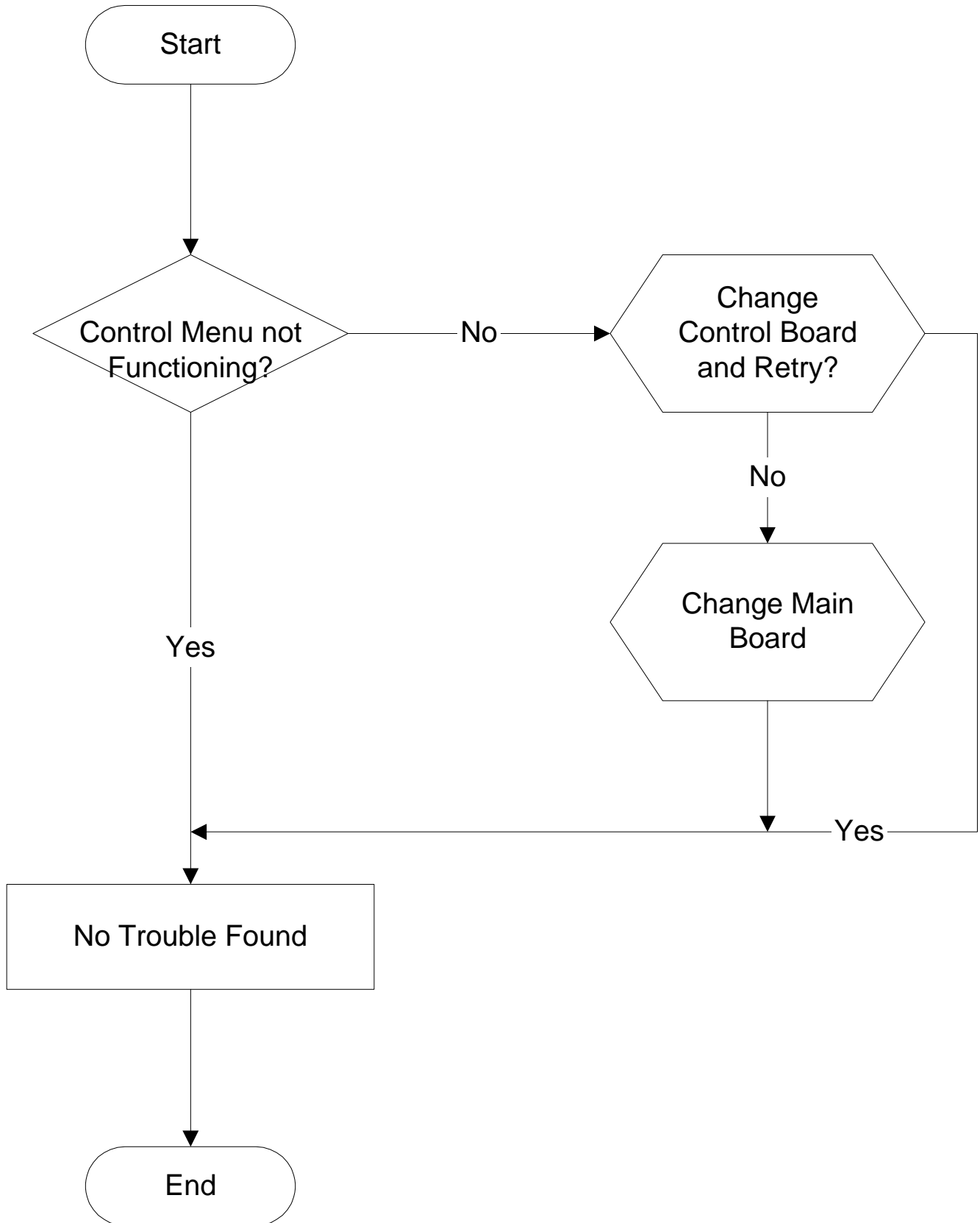

Audio Troubleshooting

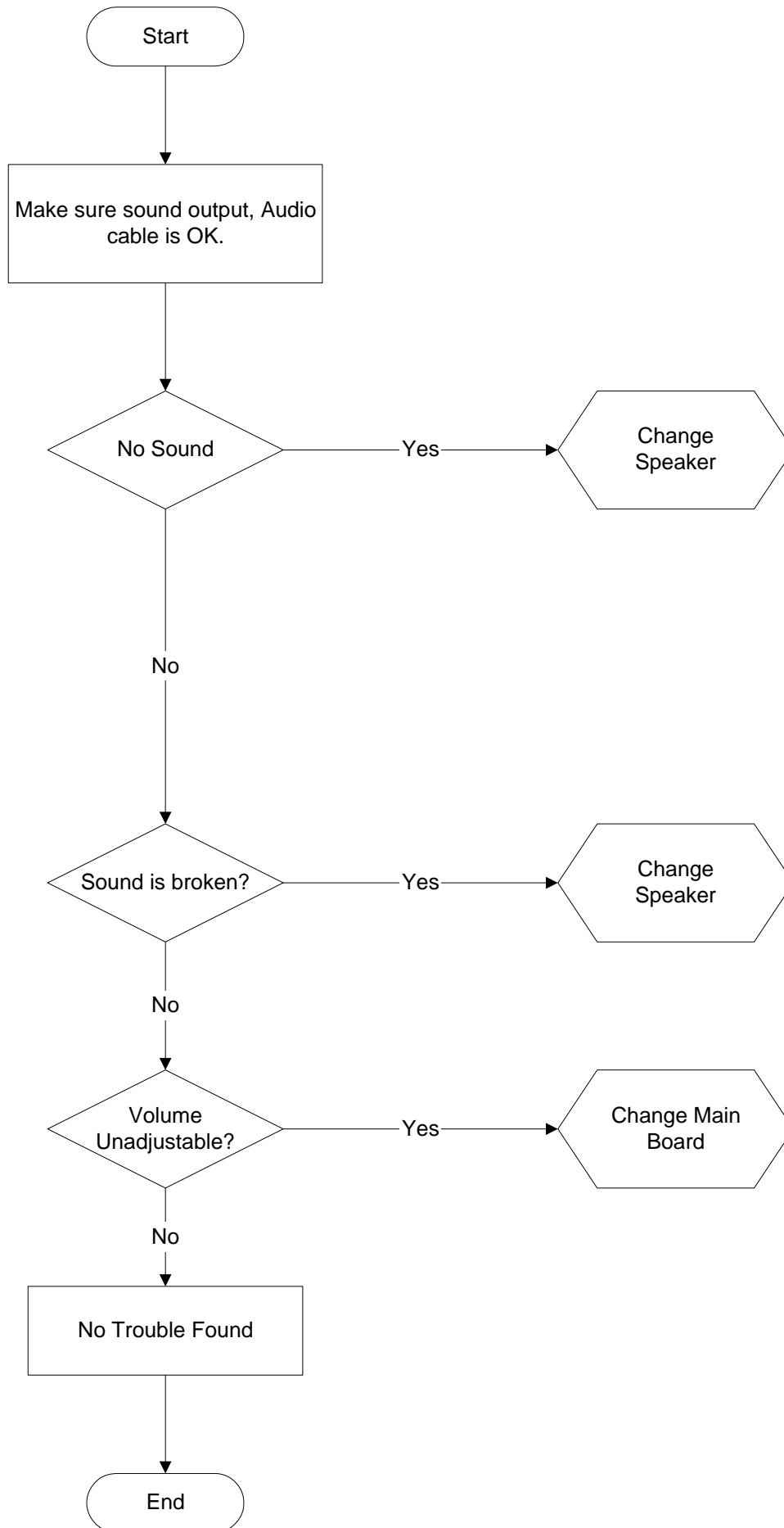

7. Recommended Spare Parts List

RECOMMENDED SPARE PARTS LIST (VG930m-3)

ViewSonic Model Number: VS11369

Serial No. Prefix: QC2

Rev: 1a

Item	Description	ECR/ECN	ViewSonic P/N	Ref. P/N	Location	Universal number#
1	Accessories: Power Cord AC		A-00008026	W402091809531		
2	PC Board Assembly:	Main Board	B-00008051	XLM19VA040002		
3		Key Board	B-00008052	XLM19VA050001		
4		Power Board + Inverter Board	B-00008053	XLM1700390015-SF		
5	Cabinets:	Front Panels	C-00008073	XLM19VA100001		
6		Housing RGB+AUDIO+DVI	C-00008074	XLM19VA110001		
7	Cables:	Audio Cable 26AWG UL2547 L=1800mm 6C	CB-00005758	W0026918A0142		
8		VGA Cable 30AWG UL20276 L1800mm	CB-00006504	W0926418AQ951		
9	Documentation:	Safety Label L150.5*W29.5	DC-00008064	F10250619VA01		
10		Blank Label	DC-00008065	F103015171A01		
11		CD	DC-00008066	F801190000021		
12	Electronic Components:	Speaker 2W	E-00008035	XLM19VA030001		
13	Hardware:	Bracket + Base	HW-00008005	XLM19VA270001		
14	Packing Material:	Foam Left	P-00008055	F2013319VA001		
15		Foam Right	P-00008056	F2014319VA001		
16		Craft Box	P-00008057	F40071619VA01		
17		Generic Foam Set	P-00001347	30833		
18		Generic Box	P-00002515	20653		

Remark 1: Above listed items are examples, supplier can expand the rows to add more necessary items.

Remark 2: All revised RSPLs with newly added items or any change made should be highlighted and correlated with the ECN/ECR approved by ViewSonic Corporation. This is to eliminate repeated cross checks of each item between this version and prior versions.

RECOMMENDED SPARE PARTS LIST (VA930M-1)

ViewSonic Model Number: VS11369

Rev: 1a

Serial No. Prefix: QEW

Item	Description	ECR/ECN	ViewSonic P/N	Ref. P/N	Location	Universal number#
1	PC Board Assembly:	MAIN BOARD ASSY	B-00008051	XLM19VA040002		
2		KEY BOARD ASSY LM/MR19V-AAAD	B-00008052	XLM19VA050001		
3		POWER BOARD+INVERTER BOARD ASSY (REV:1)	B-00008053	XLM1700390015-SF		
4	Cabinets:	FRONT PANEL BEZEL ASSY +POWER BUTTON+FUNCTION BUTTON+LENS	C-00008099	XLM19VA100002		
5		HOUSING ASSY LM/MR19V-AAAD RGB+AUDIO+DVI	C-00008074	XLM19VA110001		
6	Cables:	AUDIO CABLE 26AWG UL2547 L=1800mm 6C BLACK	CB-00005758	W0026918A0142		
7		VGA CABLE 30AWG UL20276 L1800mm 15PIN BLACK	CB-00006504	W0926418AQ951		
8		FFC CABLE CY050408001 P=1.0mm 30PIN L150mm	CB-00008033	W47A103015003		
9	Electronic Components:	LCD MODULE HSD190ME13-A16 19" LVDS HANNSTAR	E-00005792	E34862190H303-A		
10	Packing Material:	BOX	P-00008081	F40071619VA02		
11		GENERIC FOAM SET	P-00001347	30833		
12		GENERIC BOX	P-00002515	20657		
13		FOAM -L EPS	P-00008055	F2013319VA001		
14		FOAM -R EPS	P-00008056	F2014319VA001		

Remark 1: Above listed items are examples, supplier can expand the rows to add more necessary items.

Remark 2: All revised RSPLs with newly added items or any change made should be highlighted and correlated with the ECN/ECR approved by ViewSonic Corporation. This is to eliminate repeated cross checks of each item between this version and prior versions.

BOM LIST (VG930m-3)

ViewSonic Model Number: VS11369

Rev: 1a

Serial No. Prefix: QC2

Item	ViewSonic P/N	Ref. P/N	Description	Location	Universal number#	Q'ty
1	N/A	E015-006-W	(10mm*14mm) Bird logo			1
2	N/A	E015-016-1-W	VIEWSONIC AL 38MM			1
3	E-00005792	E34862190H303	LCD MODULE HSD190ME13-A16 1280x1024 [SX] 19" LVDS HANSTAR			1
4	N/A	F000417VAK001	Quick Install Manual LM/MR17V-AAAD L190*W127mm for viewsonic VG730m REV:0			1
5	N/A	F001217043001	USER'S GUIDE LM/LM1704 ENGLISH L210*W148mm for viewsonicREV:0			1
6	N/A	F101415170401	MARK LM/LM1704 L11*W11mm energy star			1
7	DC-00008064	F10250619VA01	Safety Label LM/MR19V-AAAD L150.5*W29.5mm for viewsonic VG930r			1
8	N/A	F103015170401	Blank Label LM/LM1704 L50*W25mm			1
9	DC-00008065	F103015171A01	Blank Label LM/MR171-AAA L36*W9mm for viewsonic china			1
10	N/A	F103915170401	CARTON LABEL(UPC) LM/LM1704 L76*W76mm FOR VIEWSONIC			1
11	N/A	F103915171A01	CARTON LABEL LM/MR171-AAA L89*W58mm forviewsonic 8ms			1
12	N/A	F104515170401	RATING LABEL LM/LM1704 L7*W7mm for Viewsonic			1
13	P-00008055	F2013319VA001	POLYETHYLENE -L EPS LM/MR19V-AAAD L155*W270*H565mm			1
14	P-00008056	F2014319VA001	POLYETHYLENE -R EPS LM/MR19V-AAAD L155*W270*H565mm			1
15	N/A	F300257605251	PLASTIC BAG PE L760*W525*T0.08mm			1
16	P-00008057	F40071619VA01	CARTON K3K (C Flute) LM/MR19V-AAAD L486*W278*H590mm for viewsonic VG930m			1
17	N/A	F401422LM0001	PARTITION SUPPORT BC Flute(Craft) LM/MONITOR L800*W50*H50*T5mm			0.077
18	N/A	F401422LM0002	PARTITION SUPPORT BC Flute(Craft) LM/MONITOR系列 L1800*W50*H50*T5mm			0.154
19	N/A	F40191819VA01	Top/Bottom paper sheet C Flute LM/MR19V-AAAD L1140*W980*H60mm(inside Dim.)			0.0385
20	N/A	F40191819VA02	Top/Bottom paper sheet C Flute LM/MR19V-AAAD L980*W595*H60mm(inside Dim.)			0.0385
21	N/A	F50301191A001	PALLET SMOKE WOOD LM/MR191-AAA L1140*W980*H120mm			0.0385
22	DC-00008066	F801190000021	CARTON K3K (C Flute) LM/MR19V-AAAD L486*W278*H590mm for viewsonic VG930m			1
23	N/A	F900181000001	PE LIMPID W500*T0.03mm 1500m/roll			0.00054
24	N/A	F900381000004	Pallette Wrap Film, PE LIMPID L1200*W1200*T0.15mm			0.0385
25	N/A	F9008G2000002	PACKTHREAD PP WHITE W14.5mm*T0.8mm 1300m/roll			0.00067
26	N/A	M101082807401	Screw, Machine Copper Hexagonal head L5mm Φ2.8*L7mm Nickel plate			4
27	N/A	M105243005401	SCREW MACHINE low carbon steel +/Binding head Φ3.0mm L5mm NICKEL			14
28	N/A	M105244005401	SCREW MACHINE low carbon steel +/Binding head Φ4.0*L5mm NICKEL with toothed lock washers			1
29	N/A	M105244006C01	SCREW MACHINE low carbon steel +/Binding Φ4.0*L6mm black anti-release			8
30	N/A	M155243008401	SCREW, Tapping(w/o tail cut - single thread) low carbon steel +/Binding Φ3.0*L8mm NICKEL			4
31	N/A	M621700LM0420-A	Bracket SECC LM/MR19V-AAAD REV:0			1
32	N/A	M628700LM0010-F	Supporter SECC riveted LM/MR19V-AAAD REV:0			1
33	N/A	P703A995LM1010-A	Cover, ABS HB BLACK LM/MR19V-AAAD REV:0			1
34	N/A	V300800000001	GLUE 50g/PES (: -60℃~+200℃)			0.01
35	N/A	V5004AP150201	ADHESIVE TAPE L25000*W15*T0.25mm 25m/ROLL(YW0910300002)			0.01
36	N/A	V5011A5150101	ADHESIVE TAPE L50000*W8*T0.1mm			0.0064
37	N/A	V501275024801	ADHESIVE TAPE L75m*W48*T 0.045mm FOR VIEWSONEC			0.0133
38	N/A	V900505020003	AL FOIL L50xW30xT0.10mm			2
39	N/A	V900505030001	AL FOIL L100xW40xT0.07mm			1
40	N/A	V900505030007	AL FOIL L100xW30*T0.35mm(Y78400004G*1)			4
41	CB-00005758	W0026918A0142	AUDIO CABIE 26AWG UL2547 L=1800mm 6C BLACK(N65B80-1800)			1
42	CB-00006504	W0926418AQ951	VGA CABLE 30AWG UL20276 L1800mm 15PIN BLACK			1
43	A-00008026	W402091809531	AC POWER CORD UL RVV 300/500V 3G S0.75mm2 L180cmBLACK YISHENG			1
44	N/A	W47A103015003	FFC WIRE CY050408001 P=1.0mm 30PIN L150mm HANQUAN			1
45	N/A	W47A103015004	FFC WIRE CY050408001 P=1.0mm 30PIN L150mm LOCK HUNG FU			1
46	N/A	W47B100620001	FFC WIRE FFCC0605T2350EC P=1.0mm 6TO 6PIN L200mm HANQUAN			1
47	N/A	W47B101030001	FFC WIRE FFCC0605T2350EC P=1.0mm 10PIN L300mm HANQUAN			1
48	B-00008053	XLM1700390015-SF	POWER BOARD+INVERTER BOARD ASSY PI-SB03 24V+5V LM/17/19" LCD MONITOR FOR VIEWSONIC REV:1(PHIHONG)			1
49	B-00008051	XLM19VA040002	MAIN BOARD ASSY LM/MR19V-AAAD For VG721/VG921 Common			1
50	N/A	A01F241615A21	IC EEPROM AT24C16 2500ms ATMEL SOIC-8 2K*8 (SMD)			1
51	N/A	A03D111703G03	IC LINEAR IC VOLTAGE REGULATOR GL1117A-3.3 (INPUT4.8-12V OUTPUT 3.3V) SOT-223 GTM LeadFree (SMD)			1
52	N/A	A03D111703A54	IC LINEAR VOLTAGE REGULATOR AP1117E33A SOT-223 ANACHIP (SMD)			1
53	N/A	A07D212005R01	IC MCU RTD2120L 96KB LQFP48 Realtek LeadFree (SMD)			1
54	N/A	A082523BR2001	IC ASIC/SCALER RTD2523B PQFP-128 REALTEK (SMD)			1
55	N/A	A43H206506A01	LINEAR IC POWER AMPLIFIE with Volume contorl PA2065JI 2W DIP-16PIN ANPEC (DIP)			1
56	N/A	BLM19VAM10115	BARE PCB LM/MR19V-AAAD MAIN BOARD 2SIDES FR-4 T1.6mm REV:1.5			1
57	N/A	C02205003C111	CAP MLCC NPO 5pF 50V ±0.25%(C) 0603 TAPPING (SMD)			3
58	N/A	C02210003J111	CAP MLCC NPO 10pF 50V ±5% 0603 TAPPING (SMD)			2
59	N/A	C02212003J111	CAP MLCC /NPO 12PF 50V ±5%(J) 0603 TAPPING (SMD)			1
60	N/A	C0222003J111	CAP MLCC /NPO 22PF 50V ±5%(J) 0603 TAPPING (SMD)			3
61	N/A	C02310501K111	CAP MLCC X5R 1uF 16V ±10%(K) 0603 TAPPING (SMD)			3
62	N/A	C02410302K111	CAP MLCC X7R 10nF/25V ±10%(K) 0603 TAPPING (SMD)			1
63	N/A	C02410403K111	CAP MLCC X7R 0.1uF/50V ±10%(K) 0603 TAPPING(SMD)			47
64	N/A	C02447302K111	CAP MLCC/ X7R 0.047uF /25V ±10%(K) 0603 TAPPING(SMD)			6
65	N/A	C02447401K111	CAP MLCC X7R 470nF 16V ±10%(K) 0603 TAPPING lead free (SMD)			1
66	N/A	C4021006M2431	CAP EC(S) -40~105℃ 10uF 25V ±20%(M) Φ5×H7mm P=2.5mm (DIP)			4
67	N/A	C4021014M2222	CAP EC(S) -40~105℃ 100uF 16V ±20%(M) Φ5×H11mmP=2.0mm (DIP)			6
68	N/A	C402204M2322	CAP EC -40~105℃ 22UF/16V ±20%(M) § 5*H5MM P=2.0MM (DIP)			2
69	N/A	C4022296M2122	CAP EC -40℃~105℃ 2.2uF/25V ±20%(M) §4*H5mm P=2.0mm (DIP)			1
70	N/A	C4024704M2422	CAP EC -40° ~105℃ 47UF/16V ±20%(M) § 5*H7MM P=2.0MM (DIP)			1
71	N/A	C4026813M5341	CAP EC -40~105℃ 680uF 10V ±20%(M) Φ8*H11.5mm P=3.5mm LEAD FREE (DIP)			1
72	N/A	D00BAV9905G01	DIODE BAV99 SOT-23 GTM (SMD)			11
73	N/A	D00L414803Y11	DIODE LL4148 SOD-123 YING SMD			5
74	N/A	D01Z152C03K01	ZENER BZT52C SOD-123KINGWELL 5.6V (SMD)			10
75	N/A	J41070515T201	Ear-Phone JACK_5 PIN,DIP 90°,LIME GREEN,Tekcon			1
76	N/A	J4507270155B1	D-SUB H/D,15PIN,VGA PC99(LIGHT BLUE)DIP 90°,3 ROW,1285-15S-004-98C-01,TEKCON			1
77	N/A	J4509100102H1	FFC CONNECTOR P=1mm 10PIN 90° CF16061D0T0 HANQUAN (DIP)			1

Item	ViewSonic P/N	Ref. P/N	Description	Location	Universal number#	Q'ty
78	N/A	J4509100306H1	FFC CONN ,30 PIN,1.0,DIP 180°,1 ROW,Cvilux 16301V0T0 or compatible			1
79	N/A	L004100201101	BEAD Chip Beads DDY160808U011MB 10Ω 200mA 0603(1608) TAPING MAGIC LEAD FREE (SMD)			3
80	N/A	L012121201113	BEAD CHOKE Ferrite(generalcircuit) DDY160808U121MB120Ω 200mA 0603(SMD)			8
81	N/A	L013121302A11	CHIP BEAD Ferrite Chip Beads (high current) WB201209B601QLT02 120Ω 3000mA 1206 Walsin (SMD)			5
82	N/A	Q441240047151	CRYSTAL QUARTZ 24MHZ 30PPM 20PF 49US CRE (DIP)			2
83	N/A	R070000J10311	RES CHIP 0Ω ±5%(J) 1/10W 0805 TAPPING (SMD)(Y180320000J0)			4
84	N/A	R070000J20111	05: RESISTOR.RES CHIP 0Ω ±5%(J) 1/8W 0603 TAPPING (SMD).....			9
85	N/A	R070059J61111	RES CHIP 0.5Ω ±5%(J) 1/2W 1210 TAPING LEAD FREE (SMD)			1
86	N/A	R071001J10111	RES CHIP 10Ω ±5%(J) 1/10W 0603 TAPPING(SMD)			8
87	N/A	R070470J10111	RESISTOR.RES CHIP 47Ω ±5%(J) 1/10W.0603 TAPPING(SMD)			3
88	N/A	R070750J10111	RESISTOR.RES CHIP 75Ω ±5%(J) 1/10W.0603 TAPPING(SMD).....			5
89	N/A	R071000J10111	RES CHIP 100Ω ±5%(J) 1/10W 0603 TAPPING (SMD)			15
90	N/A	R071001J20111	05: RESISTOR.RES CHIP 1KΩ ±5%(J) 1/8W.0603 TAPPING (SMD).....			6
91	N/A	R071002J20111	05: RESISTOR.RES CHIP 10KΩ ±5%(J) 1/8W.0603 TAPPING(SMD).....			6
92	N/A	R071003J10111	RES CHIP 100KΩ ±5%(J) 1/10W 0603 TAPPING (SMD)			1
93	N/A	R071004J30111	RES CHIP 1MΩ ±5%(J) 1/16W 0603 TAPPING (SMD)			1
94	N/A	R071502F30111	RES CHIP 15KΩ ±1%(F) 1/16W 0603 TAPPING (SMD)			2
95	N/A	R072001J30111	RES CHIP 2KΩ ±5%(J) 1/16W 0603 TAPPING (SMD)(Y180222001J0)			3
96	N/A	R072200J20111	05: RESISTOR.RES CHIP 220Ω ±5%(J) 1/8W.0603 TAPPING(SMD).....			7
97	N/A	R073002J10111	05: RESISTOR.RES CHIP 30KΩ ±5%(J) 1/10W.0603 TAPPING (SMD).....			1
98	N/A	R074701J20111	RESISTOR.RES CHIP 4.7KΩ ±5%(J) 1/8W.0603 TAPPING(SMD).....			12
99	N/A	R074702J20111	05: RESISTOR.RES CHIP 47KΩ ±5%(J) 1/8W.0603 TAPPING (SMD).....			2
100	N/A	R076801J10111	RES CHIP 6.8KΩ ±5%(J) 1/10W 0603 TAPPING (SMD)			2
101	N/A	R144701J20112	RES ARRAY 4.7KΩ ±5%(J) 1/10W 8P4R 3216 TAPPING (SMD)			6
102	N/A	T00T390402G01	TR GMBT3904 SOT-23 GTM (SMD)			3
103	N/A	T00T390602G01	TR GMBT3906 SOT-23 GTM (SMD)			6
104	N/A	T01A340102A21	XSTR AO3401/ST3401, SOT-23-3 , Alpha & Omega/ST			1
105	N/A	Y640224002*1	DVI HD FEMALE 24P H=20MM			1
106	N/A	Y64115HB04*1	CONNECTOR M 180°/2.0mm 1 ROW 4P			1
107	N/A	Y64115HB06*1	CONNECTOR 180° 2mm 1ROW 6PIN			1
108	B-00008052	XML19VA050001	KEY BOARD ASSY LM/MR19V-AAAD			1
109	N/A	BLM19VAB10212	BARE PCB LM/MR19V-AAAD BUTTON BOARD 1SIDE FR-1 T1.0mm REV:1.2			1
110	N/A	J4509100065H1	FFC CONN ,6 PIN,1.0,DIP 90°,1 ROW,Cvilux CF16071D0T0 or compatible			1
111	N/A	P764P281LM010-A	SWITCH PA66 WHITE 22051 LM/MR17D-AAAD REV:0			5
112	N/A	XML19VA050002	KEY BOARD ASSY LM/MR19V-AAAD 2SIDES			1
113	N/A	BLM19VAB10112	BARE PCB LM/MR19V-AAAD BUTTON BOARD 2SIDES FR-4 T1.0mm REV:1.2			1
114	N/A	D062103810001	LED BLUE+ORANGE KPB-3025 TAPING LEAD FREE (SMD)			1
115	N/A	J4509100065H1	FFC CONN ,6 PIN,1.0,DIP 90°,1 ROW,Cvilux CF16071D0T0 or compatible			1
116	N/A	J4509100102H1	FFC CONNECTOR P=1mm 10PIN 90° YELLOW CF16061D0T0 HANQUAN (DIP)			1
117	N/A	P764P295LM010	SWITCH PA66 BLACK LCD MONITOR SERIES REV:0			1
118	C-00008073	XML19VA100001	BEZEL ASSY LM/MR19V-AAAD BEZEL+POWER BUTTON+FUNCTION BUTTON+LENS			1
119	N/A	P727A900LM100-H	BEZEL ABS HB BLACK+SILVER Paint+ Logo Print LM/MR19V-AAAD REV:0			1
120	N/A	P761A998LM010-B	POWER BUTTON ABS HB SILVER Paint LM/MR19V-AAAD REV:0			1
121	N/A	P763A998LM130-B	FUNCTION BUTTON ABS HB SILVER PaintLM/MR19V-AAAD REV:0			1
122	N/A	P791P500LM060-A	LENS PMMA Transparent LM/MR19V-AAAD Texturized REV:0			1
123	C-00008074	XML19VA110001	HOUSING ASSY LM/MR19V-AAAD RGB+AUDIO+DVI			1
124	N/A	M410810130001	VASA BKT T=0.8mm SECC			4
125	N/A	M632700LM0060	Fix Plate SECC T0.8mm LM/ML17A2-a REV:0			1
126	N/A	P642004010001	Rubber Cap Round Ø4.84*H5.5mm BLACK			4
127	N/A	P728A995LM140-A	HOUSING ABS HB BLACK LM/MR19V-AAAD RGB+AUDIO+DVI REV:0			1
128	HW-00008005	XML19VA270001	MECHANICAL ASSY LM/MR19V-AAAD BRACKET+BASE			1
129	N/A	XML19VA380001	SHIELD ASSY LM/MR19V-AAAD W/Mylar			1
130	N/A	M711200LM0150-E	Shielding cover, SPTE LM/MR19V-AAAD REV:0			1
131	N/A	P369579010001	MYLAR L95*W79.5*T0.1mm WHITH ADHESIVE			1

BOM LIST (VA930M-1)

ViewSonic Model Number: VS11369

Rev: 1a

Serial No. Prefix: QEW

Item	ViewSonic P/N	Ref. P/N	Description	Location	Universal number#	Q'ty
1	N/A	E015-006-W	(10mm*14mm) Bird_logc			1
2	N/A	E015-016-1-W	VIEWSONIC AL38MM			1
3	E-00005792	E34862190H303-A	LCD MODULE HSD190ME13-A16 1280*1024 [SX] 19" LVDS HANNSTAR(8B0/G0/A0"A" FOR VA/VG			1
4	N/A	F000417VAK001	Quick Install Manual LM/MR17V-AAAD L190*W127mm for viewsonic VG730m REV:0			1
5	N/A	F001217043001	USER'S GUIDE LM/LM1704 ENGLISH L210*W148mm for ViewsonicREV:0			1
6	N/A	F001217VA3001	Explanation card LM/MR17V-AAAD ENGLISH L210*W148mm for viewsonic VA730m REV:0			1
7	N/A	F101415170401	MARK LM/LM1704 L11*W11mm energy star			1
8	N/A	F10250619VA02	Safety Label LM/MR19V-AAAD L150.5*W29.5mm for viewsonic VA930m HSI			1
9	N/A	F103015170401	Blank Label LM/LM1704 L50*W25mm			1
10	DC-00008065	F103015171A01	Blank Label LM/MR17I-AAA L36*W9mm for viewsonic chin			1
11	N/A	F103915170401	CARTON LABEL(UPC) LM/LM1704 L76*W76mm FOR VIEWSONIC			1
12	N/A	F103915171A01	CARTON LABEL LM/MR17I-AAA L89*W58mm forviewsonic 8m			1
13	N/A	F10451019VA01	RATING LABEL LM/MR19V-AAAD L322*W14mm for viewsonic VA930n			1
14	N/A	F104515170401	RATING LABEL LM/LM1704 L7*W7mm for Viewsonic			1
15	P-00008055	F2013319VA001	POLYETHYLENE -L EPS LM/MR19V-AAAD L155*W270*H565mm			1
16	P-00008056	F2014319VA001	POLYETHYLENE -R EPS LM/MR19V-AAAD L155*W270*H565mm			1
17	N/A	F300257605251	PLASTIC BAG PE L760*W525*T0.08mm			1
18	P-00008081	F40071619VA02	CARTON K3K LM/MR19V-AAAD L486*W278*H590mm for viewsonic VA930n			1
19	N/A	F401422LM0001	PARTITION SUPPORT BC Flute(Craft) LM/MONITOR L800*W50*H50*T5mm			0.077
20	N/A	F401422LM0002	PARTITION SUPPORT BC Flute(Craft) LM/MONITOR系列 L1800*W50*H50*T5mm			0.154
21	N/A	F40191819VA01	Top/Bottom paper sheet C Flute LM/MR19V-AAAD L1140*W980*H60mm(inside Dim.)			0.0385
22	N/A	F40191819VA02	Top/Bottom paper sheet C Flute LM/MR19V-AAAD L980*W595*H60mm(inside Dim.)			0.0385
23	N/A	F50301191A001	PALLET SMOKE WOOD LM/MR19I-AAA L1140*W980*H120mm			0.0385
24	N/A	F801190000023	CD MANUAL LM/MR19V-AAAD for viewsonic VA930m HSD REV:0			1
25	N/A	F900181000001	PE LIMPID W500*T0.03mm 1500m/roll			0.00054
26	N/A	F900381000004	Pallette Wrap Film, PE LIMPID L1200*W1200*T0.15mm			0.0385
27	N/A	F9008G2000002	PACKTHREAD PP WHITE W14.5mm*T0.8mm 1300m/rol			0.00067
28	N/A	M101082807401	Screw, Machine Copper Hexagonal head L5mm Φ2.8*L7mm Nickel plat			4
29	N/A	M104254008401	SCREW MACHINE/STEELΦ4xL8mm NICKEL			4
30	N/A	M105243005401	SCREW MACHINE low carbon steel + Binding head Φ3.0mm L5mm NICKEL			14
31	N/A	M105244005401	SCREW MACHINE low carbon steel +/Binding head Φ4.0*L5mm NICKEL with toothed lock washers			1
32	N/A	M105244006C01	SCREW MACHINE low carbon steel +/Binding Φ4.0*L6mm black anti-release			4
33	N/A	M155233008401	SCREW P head Φ3.0* L8mm NICKEL			4
34	N/A	M621700LM0420-A	Bracket SECC LM/MR19V-AAAD REV:0			1
35	N/A	M628700LM0010-F	Supporter SECC riveted LM/MR19V-AAAD REV:0			1
36	N/A	P703A995LM010-A	Cover, ABS HB BLACK LM/MR19V-AAAD REV:0			1
37	N/A	V308000000001	GLUE 50g/PES (: - 60°C ~+200°C)			0.01
38	N/A	V5004AP150201	ADHESIVE TAPE L25000*W15*T0.25mm 25m/ROLL(YW0910300002)			0.01
39	N/A	V5011A5150101	ADHESIVE TAPE L50000*W8*T0.1mm			0.0064
40	N/A	V501275024801	ADHESIVE TAPE L75m*W48*T 0.045mm FOR VIEWSONEC			0.0133
41	N/A	V900505020003	AL FOIL L50xW30xT0.10mm			1
42	N/A	V900505030001	AL FOIL L100xW40xT0.07mm			1
43	N/A	V900505030007	AL FOIL L100xW30*T0.35mm(Y78400004G*1)			4
44	CB-00005758	W0026918A0142	AUDIO CABIE 26AWG UL2547 L=1800mm 6C BLACK(N65B80-1800)			1
45	CB-00006504	W0926418AQ951	VGA CABLE 30AWG UL20276 L1800mm 15PIN BLACK			1
46	A-00008026	W402091809531	AC POWER CORD UL RVV 300/500V 3G S0.75mm2 L180cmBLACK YISHENG			1
47	CB-00008033	W47A103015003	FFC WIRE CY050408001 P=1.0mm 30PIN L150mm HANQUAN			1
48	N/A	W47A103015004	FFC WIRE CY050408001 P=1.0mm 30PIN L150mm LOCK HUNG FU			1
49	N/A	W47B100620001	FFC WIRE FFCC060512350EC P=1.0mm 6TO 6PIN L200mm HANQUAN			1
50	N/A	W47B101030001	FFC WIRE FFCC060512350EC P=1.0mm 10PIN L300mm HANQUAN			1
51	B-00008053	XLM1700390015-SF	POWER BOARD+INVERTER BOARD ASSY PI-SB03 24V+5V LM/17"/19" LCD MONITOR FOR VIEWSONIC REV:1(PHIHONG)			1
52	N/A	XLM1700390015-SH	POWER BOARD+INVERTER BOARD ASSY PI-SB03 24V+5V LM/17"/19" LCD MONITOR FOR VIEWSONIC REV:1(UMEC)			1
53	E-00008035	XLM19VA030001	SPEAKER ASSY LM/MR19V-AAAD			1
54	N/A	E231080200020	SPEAKER 4020CPC OBLONG 8Ω 2W 4PIN*1孔 L+R/L450mmY&G LEAD FREE			1
55	N/A	P392522A40001	SPEAKER SPONGE L25*W22.25*H14.1mm EVA(25%)			4
56	B-00008051	XLM19VA040002	MAIN BOARD ASSY LM/MR19V-AAAD For VG721/VG921 Common			1
57	N/A	A01F241615A21	IC EEPROM AT24C16 2500ns ATMEL SOIC-8 2K*8 (SMD)			1
58	N/A	A03D111703G03	IC LINEAR IC VOLTAGE REGULATOR GL1117A-3.3 (INPUT4.8-12V OUTPUT 3.3V) SOT-223 GTM LeadFree (SMD)			1
59	N/A	A03D111703A54	IC LINEAR VOLTAGE REGULATOR AP1117E33A SOT-223 ANACHIP (SMD)			1
60	N/A	A03D111703U01	VOLTAGE REGULATOR LD1117-18-A SOT-223 3PIN 1.8V UTC (SMD)			1
61	N/A	A03D111703A53	IC Linear voltage converter AP1117E18A SOT-223-3Pin(SMD)			1
62	N/A	A03D916403R01	IC , Analog , Regulator , RT9164-18CG , SOT223-3 , Richtek			1
63	N/A	A07D212005R01	IC MCU RTD2120L 96KB LQFP48 Realtek LeadFree (SMD)			1
64	N/A	A082523BR2001	IC ASIC/SCALER RTD2523B PQFP-128 REALTEK (SMD)			1
65	N/A	A43H206506A01	LINEAR IC POWER AMPLIFIE with Volume contorl PA2065J1 2W DIP-16PIN ANPEC (DIP)			1
66	N/A	BLM19VAM10116	BARE PCB LM/MR19V-AAAD MAIN BOARD 2SIDES FR-4 Tl.6mm REV:1.6			1
67	N/A	C02205003C111	CAP MLCC NPO 5pF 50V ±0.25%(C) 0603 TAPPING (SMD)			3
68	N/A	C02210003J111	CAP MLCC NPO 10pF 50V ±5% 0603 TAPPING (SMD)			1
69	N/A	C02212003J111	CAP MLCC /NPO 12PF 50V ±5%(J) 0603 TAPPING (SMD)			1
70	N/A	C02222003J111	CAP MLCC /NPO 22PF 50V ±5%(J) 0603 TAPPING (SMD)			3
71	N/A	C02310501K111	CAP MLCC X5R 1uF 16V ±10%(K) 0603 TAPPING (SMD)			1
72	N/A	C02410302K111	CAP MLCC X7R 10nF/25V ±10%(K) 0603 TAPPING (SMD)			1
73	N/A	C02410403K111	CAP MLCC X7R 0.1uF/50V ±10%(K) 0603 TAPPING(SMD)			46
74	N/A	C02447302K111	CAP MLCC/ X7R 0.047uF /25V ±10%(K) 0603 TAPPING(SMD)			6
75	N/A	C02447401K111	CAP MLCC X7R 470nF 16V ±10%(K) 0603 TAPPING lead free (SMD)			1
76	N/A	C4021006M2431	CAP EC(S) -40-105°C 10uF 25V ±20%(M) Φ5×H7mm P=2.5mm (DIP)			4
77	N/A	C4021014M2222	CAP EC(S) -40-105°C 100uF 16V ±20%(M) Φ5×H11mmP=2.0mm (DIP)			6

Item	ViewSonic P/N	Ref. P/N	Description	Location	Universal number#	Q'ty
78	N/A	C4022204M2322	CAP EC -40~105°C 22UF/16V ±20%(M) § 5*H5MM P=2.0MM (DIP)			2
79	N/A	C4022296M2122	CAP EC -40°C~105°C 2.2uF/25V ±20%(M) ψ4*H5mm P=2.0mm (DIP)			1
80	N/A	C4024704M2422	CAP EC -40° ~105°C 47UF/16V ±20% (M) § 5*H7MM P=2.0MM (DIP)			1
81	N/A	C4026813M5341	CAP EC -40~105°C 680uF 10V ±20%(M) Φ8*H11.5mm P=3.5mm LEAD FREE (DIP)			1
82	N/A	D00BAY9905G01	DIODE BAV99 SOT-23 GTM (SMD)			11
83	N/A	D00L414803Y11	DIODE LL4148 SOD-123 YING SMD			5
84	N/A	D01ZT52C03K01	ZENER BZT52C SOD-123KINGWELL 5.6V (SMD)			10
85	N/A	J41070515T201	Ear-Phone JACK_5 PIN.DIP 90°_LIME GREEN,Tekcon			1
86	N/A	J4507270155B1	D-SUB H/D,15PIN,VGA PC99(LIGHT BLUE)DIP 90°,3 ROW,1285-15S-004-98C-01,TEKCON			1
87	N/A	J4509100102H1	FFC CONNECTOR P=1mm 10PIN 90° CF16061D0T0 HANQUAN (DIP)			1
88	N/A	J4509100306H1	FFC CONN _30 PIN,1.0,DIP 180°,1 ROW,Cvilux 16301V0T0 or compatible			1
89	N/A	L004100201101	BEAD Chip Beads DDY160808U011MB 10Ω 200mA 0603(1608) TAPING MAGIC LEAD FREE (SMD)			3
90	N/A	L012121201113	BEAD CHOKE Ferrite(generalcircuit) DDY160808U121MB120Ω 200mA 0603(SMD)			8
91	N/A	L013121302A11	CHIP BEAD Ferrite Chip Beads (high current) WB201209B601QLT02 120Ω 3000mA 1206 Walsin (SMD)			5
92	N/A	Q441240047151	CRYSTAL QUARTZ 24MHZ 30PPM 20PF 49US CRE (DIP)			2
93	N/A	R07000010311	RES CHIP 0Ω ±5%(J) 1/10W 0805 TAPPING (SMD)(Y180320000J0)			4
94	N/A	R070000J20111	05: RESISTOR.RES CHIP 0Ω ±5%(J),1/8W 0603 TAPPING (SMD).....			9
95	N/A	R070059J61111	RES CHIP 0.5Ω ±5%(J) 1/2W 1210 TAPING LEAD FREE (SMD)			1
96	N/A	R070100J10111	RES CHIP 10Ω ±5%(J) 1/10W 0603 TAPPING(SMD)			8
97	N/A	R070470J10111	RESISTOR.RES CHIP 47Ω ±5%(J) 1/10W.0603 TAPPING(SMD)			3
98	N/A	R070750J10111	RESISTOR.RES CHIP 75Ω ±5%(J) 1/10W.0603 TAPPING(SMD).....			5
99	N/A	R071000J10111	RES CHIP 100Ω ±5%(J) 1/10W 0603 TAPPING (SMD)			15
100	N/A	R071001J20111	05: RESISTOR.RES CHIP 1KΩ ±5%(J) 1/8W.0603 TAPPING (SMD).....			6
101	N/A	R071002J20111	05: RESISTOR.RES CHIP 10KΩ ±5%(J) 1/8W.0603 TAPPING(SMD).....			6
102	N/A	R071003J10111	RES CHIP 100KΩ ±5%(J) 1/10W 0603 TAPPING (SMD)			1
103	N/A	R071004J30111	RES CHIP 1MΩ ±5%(J) 1/16W 0603 TAPPING (SMD)			1
104	N/A	R071502F30111	RES CHIP 15KΩ ±1%(F) 1/16W 0603 TAPPING (SMD)			2
105	N/A	R072001J30111	RES CHIP 2KΩ ±5%(J) 1/16W 0603 TAPPING (SMD)(Y180222001J0)			3
106	N/A	R072200J20111	05: RESISTOR.RES CHIP 220Ω ±5%(J) 1/8W.0603 TAPPING(SMD).....			7
107	N/A	R073002J10111	05: RESISTOR.RES CHIP 30KΩ ±5%(J) 1/10W.0603 TAPPING (SMD).....			1
108	N/A	R074701J20111	RESISTOR.RES CHIP 4.7KΩ ±5%(J) 1/8W.0603 TAPPING(SMD).....			12
109	N/A	R074702J20111	05: RESISTOR.RES CHIP 47KΩ ±5%(J) 1/8W.0603 TAPPING (SMD).....			2
110	N/A	R076801J10111	RES CHIP 6.8KΩ ±5%(J) 1/10W 0603 TAPPING (SMD)			2
111	N/A	R144701J20112	RES ARRAY 4.7KΩ ±5%(J) 1/10W 8P4R 3216 TAPPING (SMD)			6
112	N/A	T00T390402G01	TR GMBT3904 SOT-23 GTM (SMD)			3
113	N/A	T00T390602G01	TR GMBT3906 SOT-23 GTM (SMD)			6
114	N/A	T01A340102A21	XSTR AO3401/ST3401, SOT-23_3_ Alpha & Omega/ST			1
115	N/A	Y640224002*1	DVI HD FEMALE 24P H=20MM			1
116	N/A	Y64115HB04*1	CONNECTOR M 180°2.0mm 1 ROW 4P			1
117	N/A	Y64115HB06*1	CONNECTOR 180° 2mm 1ROW 6PIN			1
118	B-00008052	XLM19VA050001	KEY BOARD ASSY LM/MR19V-AAAD			1
119	N/A	BLM19VAB10212	BARE PCB LM/MR19V-AAAD BUTTON BOARD 1SIDE FR-1 T1.0mm REV:1.2			1
120	N/A	J4509100065H1	FFC CONN _6 PIN,1.0,DIP 90°,1 ROW,Cvilux CF16071D0T0 or compatible			1
121	N/A	P764P281LM010-A	SWITCH PA66 WHITE 22051 LM/MR17D-AAAD REV:0			5
122	N/A	XLM19VA050002	KEY BOARD ASSY LM/MR19V-AAAD 2SIDES			1
123	N/A	BLM19VAB10112	BARE PCB LM/MR19V-AAAD BUTTON BOARD 2SIDES FR-4 T1.0mm REV:1.2			1
124	N/A	D062103810001	LED BLUE+ORANGE KPB-3025 TAPING LEAD FREE (SMD)			1
125	N/A	J4509100065H1	FFC CONN _6 PIN,1.0,DIP 90°,1 ROW,Cvilux CF16071D0T0 or compatible			1
126	N/A	J4509100102H1	FFC CONNECTOR P=1mm 10PIN 90° YELLOW CF16061D0T0 HANQUAN (DIP)			1
127	N/A	P764P295LM010	SWITCH PA66 BLACK LCD MONITOR SERIES REV:0			1
128	C-00008099	XLM19VA100002	BEZEL ASSY LM/MR19V-AAAD BEZEL+POWER BUTTON+FUNCTION BUTTON+LENS VA930m			1
129	N/A	P727A900LM100-B	BEZEL ABS HB BLACK+SILVER Paint+ Logo Print LM/MR19V-AAAD REV:0			1
130	N/A	P761A998LM010-B	POWER BUTTON ABS HB SILVER Paint LM/MR19V-AAAD REV:0			1
131	N/A	P763A998LM130-B	FUNCTION BUTTON ABS HB SILVER PaintLM/MR19V-AAAD REV:0			1
132	N/A	P791P500LM060-A	LENS PMMA Transparent LM/MR19V-AAAD Texturized REV:0			1
133	C-00008074	XLM19VA110001	HOUSING ASSY LM/MR19V-AAAD RGB+AUDIO+DVI			1
134	N/A	M410810130001	VASA BKT T=0.8mm SECC			4
135	N/A	M632700LM0060	Fix Plate SECC T0.8mm LM/ML17A2-a REV:0			1
136	N/A	P642004010002	Rubber Cap Round Φ4.84*H5.5mm BLACK			4
137	N/A	P728A995LM140-A	HOUSING ABS HB BLACK LM/MR19V-AAAD RGB+AUDIO+DVI REV:0			1
138	HW-00008005	XLM19VA270001	MECHANICAL ASSY LM/MR19V-AAAD BRACKET+BASE			1
139	N/A	XLM19VA380001	SHIELD ASSY LM/MR19V-AAAD W/Mylar			1
140	N/A	M711200LM0150-E	Shielding cover, SPTE LM/MR19V-AAAD REV:0			1
141	N/A	P369579010001	MYLAR L95*W79.5*T0.1mm WHITH ADHESIVE			1

8. Exploded Diagram and Exploded Parts List

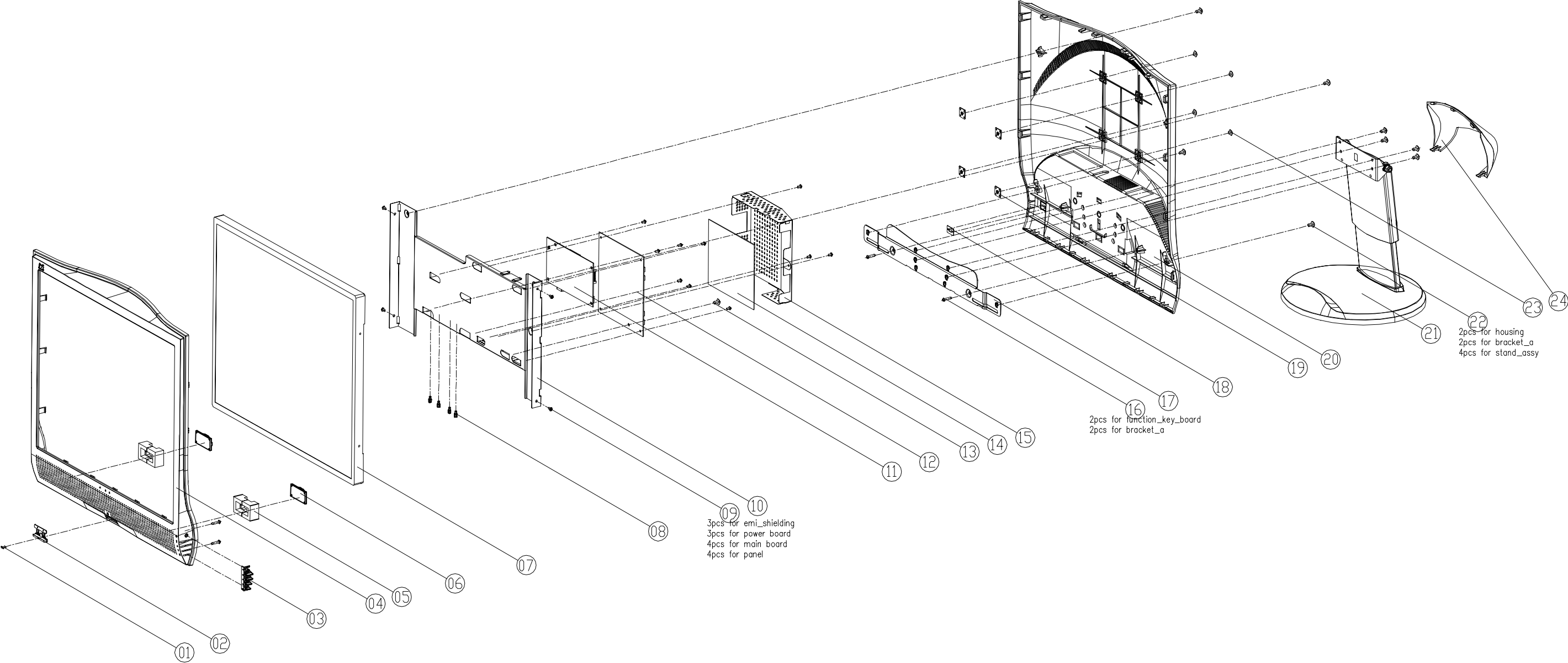

EXPLODED PARTS LIST (VA930m-1)

ViewSonic Model Number: VS11369

Rev: 1a

Serial No. Prefix: QEW

Item	ViewSonic P/N	Ref. P/N	Description	Q'ty
1	N/A	P791P500LM060-A	LENS PMMA LM/MR19V-AAAD	1
2	N/A	P761A998LM010-B	POWER BUTTON ABS HB SILVER LM/MR19V-AAAD REV:0	1
3	N/A	P763A99BLM130-B	FUNCTION BUTTON ABS HB SILVER LM/MR19V-AAAD REV.0	1
4	N/A	P727A900LM101-B	BEZEL ABS HB SILVER+BLACK LM/MR19V-AAAD FOR VA930m REV:1	1
5	N/A	P392522A40001	SPEAKER SPONGEL25*W22.25*H14.1mmEVA	4
6	N/A	E231080200020	SPEAKER 4020CPC OBLONG 8Ω 2W4PIN	1
7	E-00005792	E34862190H303	LCD MODULE HSD190ME13-A16 1280×1024 [SX] 19" LVDSHANNSTAR	1
8	N/A	M101082807401	SCREWMACHINE H Φ2.8*L7mm	4
9	N/A	M105243005401	SCREW MACHINE B(Binding) Φ3.0mm L5mm NICKEL	14
10	N/A	M621700LM0420-A	Bracket SECC	1
11	B-00008051	XLM19VA040002	MAIN BOARD ASSY LM/MR19V- AAAD For VG730/VG930	1
12	B-00008053	XLM1700390015-SF	POWER BOARD+INVERTER BOARD	1
13	N/A	M105244005401	SCREW MACHINE B Φ4.0*L5mm NICKEL withtoothed lock washers	1
14	N/A	P369579010001	MYLARL95*W79.5*T0.125mmWHITH ADHESIVE	1
15	N/A	M711200LM0150-E	SPTL M/MR19V-AAAD	1
16	N/A	M155223008401	SCREW +/- P Φ3.0* L8mm NICKEL	4
17	N/A	M628700LM0010-F	Supporter SECC LM/MR19V-AAAD REV:0	1
18	N/A	M632700LM0060	FIX PLATE SECC T0.8mmLM/ML17A2-a REV.0	1
19	N/A	M410810130001	VASA BKT T=0.8mmSECC	4
20	N/A	P728A995LM140-A	HOUSING ABS HB BLACK LM/MR19V-AAAD	1
21	HW-00008005	XLM19VA270001	MECHANICAL ASSY LM/MR19V-AAAD BRACKET+BASE	1
22	N/A	M105244006C01	SCREW MACHINE +/-BΦ4.0*L6mm	8
23	N/A	P642004010001	Φ4.84*H5.5mmBLACK	4
24	N/A	P703A995LM010-A	ABS HB BLACK LM/MR19V-AAAD REV:0	1

EXPLODED PARTS LIST (VG930m-3)

ViewSonic Model Number: VS11369

Rev: 1a

Serial No. Prefix: QC2

Item	ViewSonic P/N	Ref. P/N	Description	Q'ty
1	N/A	P791P500LM060-A	LENS PMMA LM/MR19V-AAAD	1
2	N/A	P761A99BLM010-B	POWER BUTTON ABS HB SILVER LM/MR19V-AAAD REV.0	1
3	N/A	P763A99BLM130-B	FUNCTION BUTTON ABS HB SILVER LM/MR19V-AAAD REV.0	1
4	N/A	P727A900LM100-H	BEZEL ABS HB BLACK+SILVER LM/MR19V-AAAD REV.0	1
5	N/A	P392522A40001	SPEAKER SPONGEL25*W22.25*H14.1mmEVA	4
6	N/A	E231080200020	SPEAKER 4020CPC OBLONG 8Ω 2W4PIN	1
7	E-00005792	E34862190H303	LCD MODULE HSD190ME13-A16 1280×1024 [SX] 19" LVDSHANNSTAR	1
8	N/A	M101082807401	SCREWMACHINE H Φ2.8*L7mm	4
9	N/A	M105243005401	SCREW MACHINE B(Binding) Φ3.0mm L5mm NICKEL	14
10	N/A	M621700LM0420-A	Bracket SECC	1
11	B-00008051	XLM19VA040002	MAIN BOARD ASSY LM/MR19V- AAAD For VG730/VG930	1
12	B-00008053	XLM1700390015-SF	POWER BOARD+INVERTER BOARD	1
13	N/A	M105244005401	SCREW MACHINE B Φ4.0*L5mm NICKEL withtoothed lock washers	1
14	N/A	P369579010001	MYLARL95*W79.5*T0.125mmWHITH ADHESIVE	1
15	N/A	M711200LM0150-E	SPTL M/MR19V-AAAD	1
16	N/A	M155223008401	SCREW +/- P Φ3.0* L8mm NICKEL	4
17	N/A	M628700LM0010-F	Supporter SECC LM/MR19V-AAAD REV:0	1
18	N/A	M632700LM0060	FIX PLATE SECC T0.8mmLM/ML17A2-a REV.0	1
19	N/A	M410810130001	VASA BKT T=0.8mmSECC	4
20	N/A	P728A995LM140-A	HOUSING ABS HB BLACK LM/MR19V-AAAD	1
21	HW-00008005	XLM19VA270001	MECHANICAL ASSY LM/MR19V-AAAD BRACKET+BASE	1
22	N/A	M105244006C01	SCREW MACHINE +/-BΦ4.0*L6mm	8
23	N/A	P642004010001	Φ4.84*H5.5mmBLACK	4
24	N/A	P703A995LM010-A	ABS HB BLACK LM/MR19V-AAAD REV:0	1

PACKING PART LIST (VA930m-1)

ViewSonic Model Number: VS11369

Rev: 1a

Item	ViewSonic P/N	Ref. P/N	Location	Q'ty
1	P-00008081	F40071619VA02	CARTON K3K LM/MR19V-AAAD L486*W278*H590mm for viewsonic VA930m	1
2	P-00008056	F2014319VA001	POLYETHYLENE -R EPS LM/MR19V-AAAD L155*W270*H565mm	1
3	P-00008055	F2013319VA001	POLYETHYLENE -L EPSLM/MR19V-AAADL155*W270*H565mm	1
4	A-00008026	W402091809531	AC POWER CORD US RVV300/500V 3G S0.75mm2 L180cm BLACK	1
5	CB-00005758	W0026918A0142	AUDIO CABIE 26AWG UL2547 L=1800mm 6C BLACK	
6	CB-00006504	W0926418AQ951	VGA CABLE 30AWG UL20276 L1800mm 15PIN BLACK	1
7	N/A	F801190000012	CD ENGLISH+FRRENCH+GERMANY+ITALY+SPAIN+FINLAND+JAPANESE+KOREA N+CZECH+CHINESELM/MR19I-AAA FOR VIEWSONIC CMO REV:0	1
8	N/A	F300272501501	PLASTIC BAG LDPE L250*W150*T0.08mm	1
9	N/A	YLM19VAR73A01	FINISH GOODS LM/MR19V-AAAD RGB+DVI+AUDIO HANNSTAR USA UL mark CB+CUL+UL+SASO+OTHER FOR ViewSonic	1
10	P-00008176	F300257605251	PLASTIC BAG PE L760*W525*T0.08mm	1

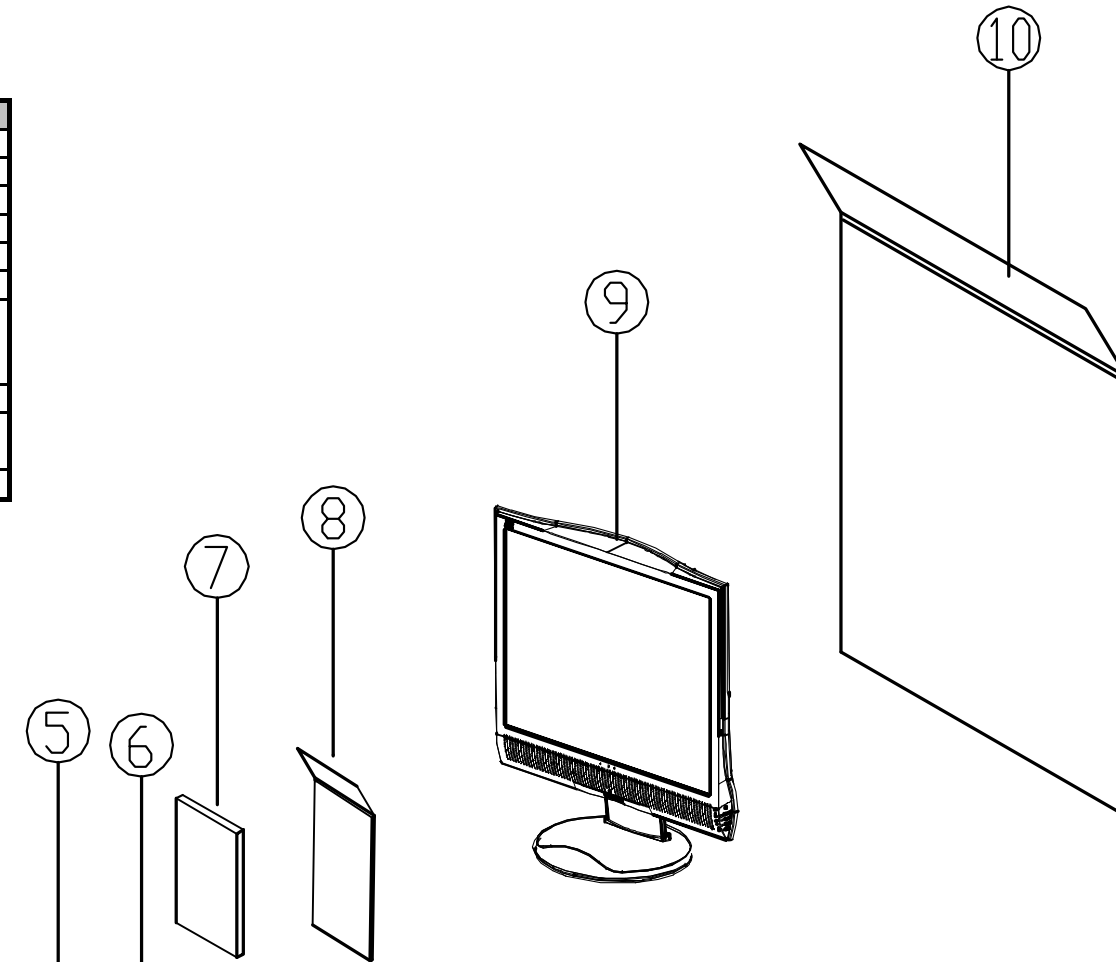
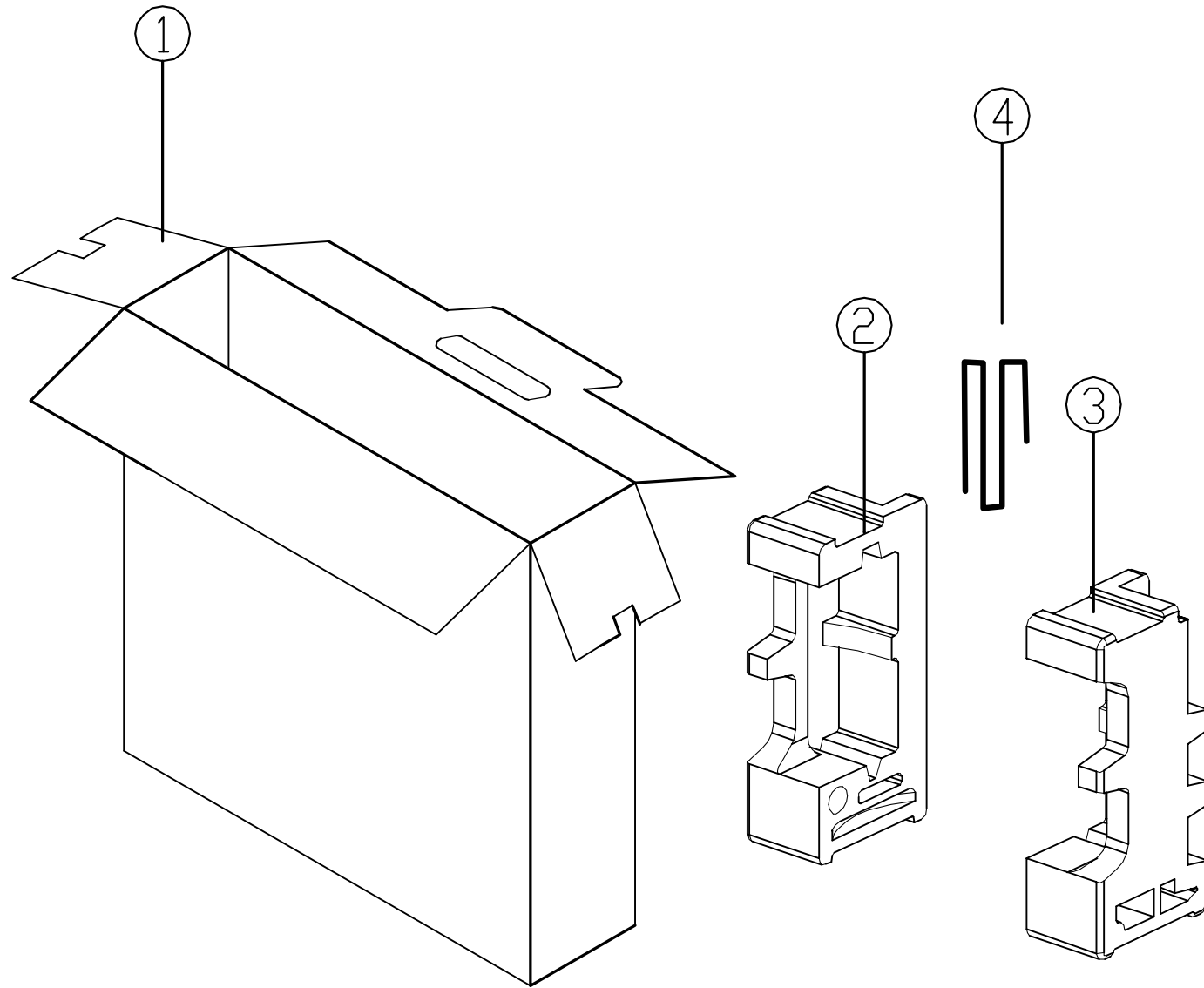

PACKING PART LIST (VG930m-3)

ViewSonic Model Number: VS11369

Rev: 1a

Item	ViewSonic P/N	Ref. P/N	Location	Q'ty
1	P-00008057	F40071619VA01	CARTON K4K (C)LM/MR19V- AAAD L486*W278*H590mm for viewsonic VG930m	1
2	P-00008056	F2014319VA001	POLYETHYLENE -R EPS LM/MR19V-AAAD L155*W270*H565mm	1
3	P-00008055	F2013319VA001	POLYETHYLENE -L EPSLM/MR19V-AAADL155*W270*H565mm	1
4	A-00008026	W402091809531	AC POWER CORD US RVV300/500V 3G S0.75mm2 L180cm BLACK	1
5	CB-00005758	W0026918A0142	AUDIO CABIE 26AWG UL2547 L=1800mm 6C BLACK	
6	CB-00006504	W0926418AQ951	VGA CABLE 30AWG UL20276 L1800mm 15PIN BLACK	1
7	N/A	F801190000012	CD ENGLISH+FRRENCH+GERMANY+ITALY+SPAIN+FINLAND+JAPANESE+KOREAN+CZECH+CHINESE M/MR19I-AAA FOR VIEWSONIC CMO REV:0	1
8	N/A	F300272501501	PLASTIC BAG LDPE L250*W150*T0.08mm	1
9	N/A	YLM19VAR73A01	FINISH GOODS LM/MR19V-AAAD RGB+DVI+AUDIO HANNSTAR USA UL mark CB+CUL+UL+SASO+OTHER FOR ViewSonic	1
10	P-00008176	F300257605251	PLASTIC BAG PE L760*W525*T0.08mm	1

9. Block Diagram

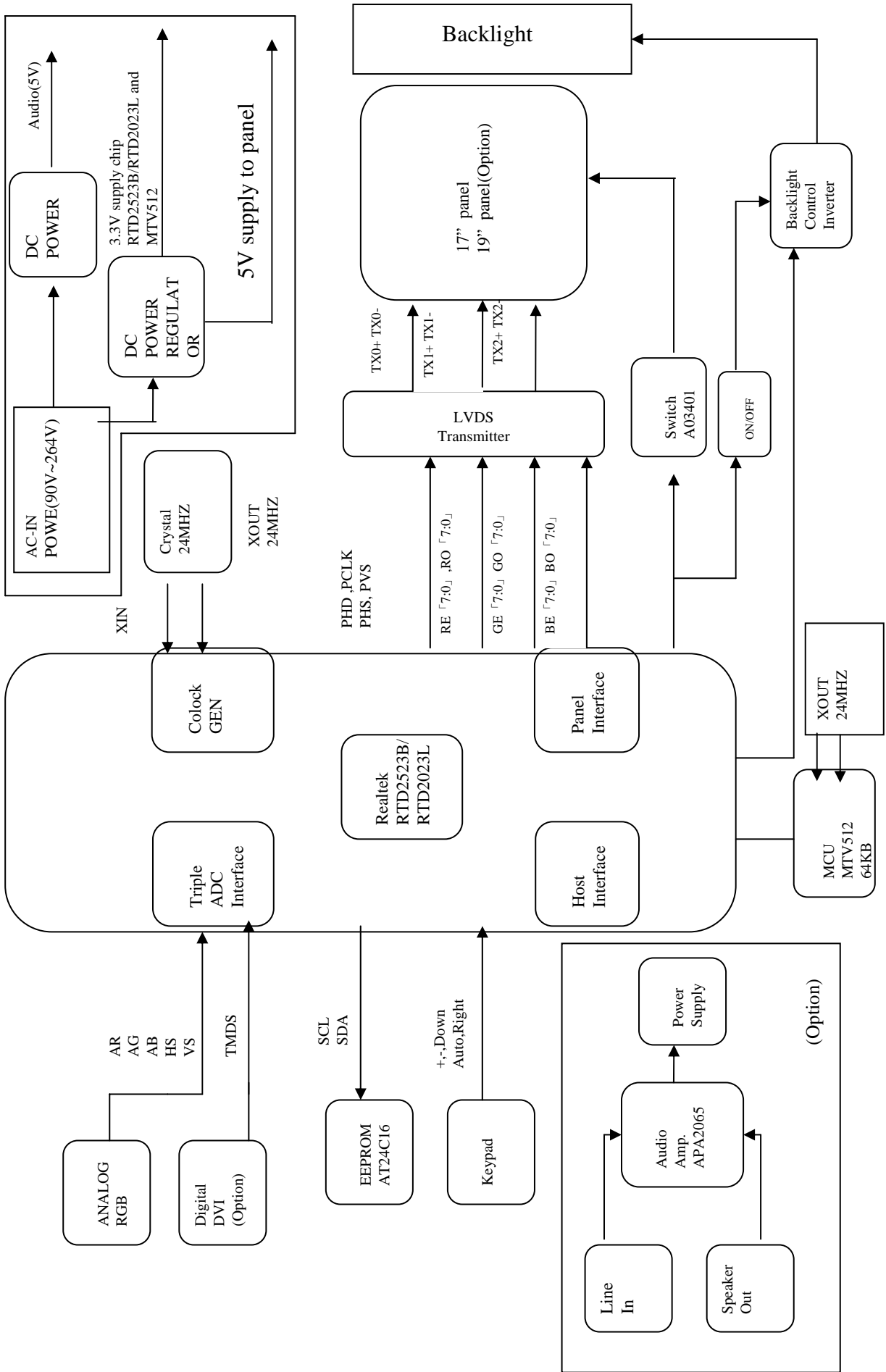

10. Schematic Diagrams

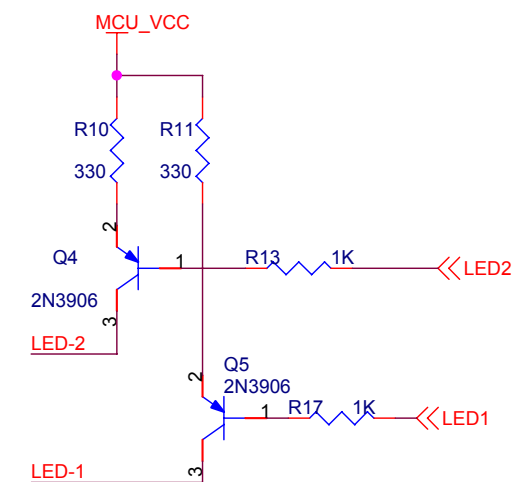
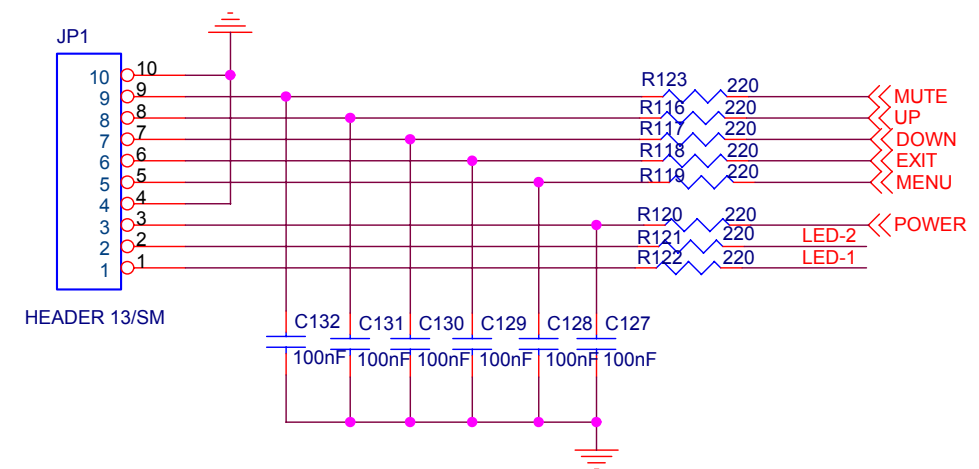
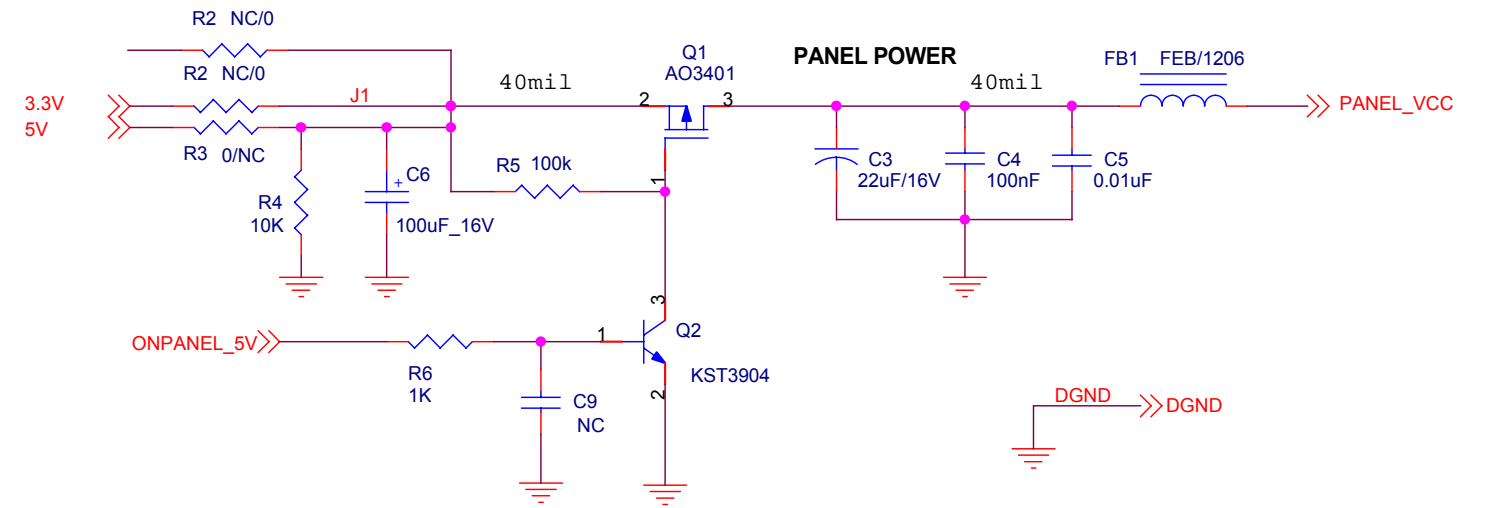
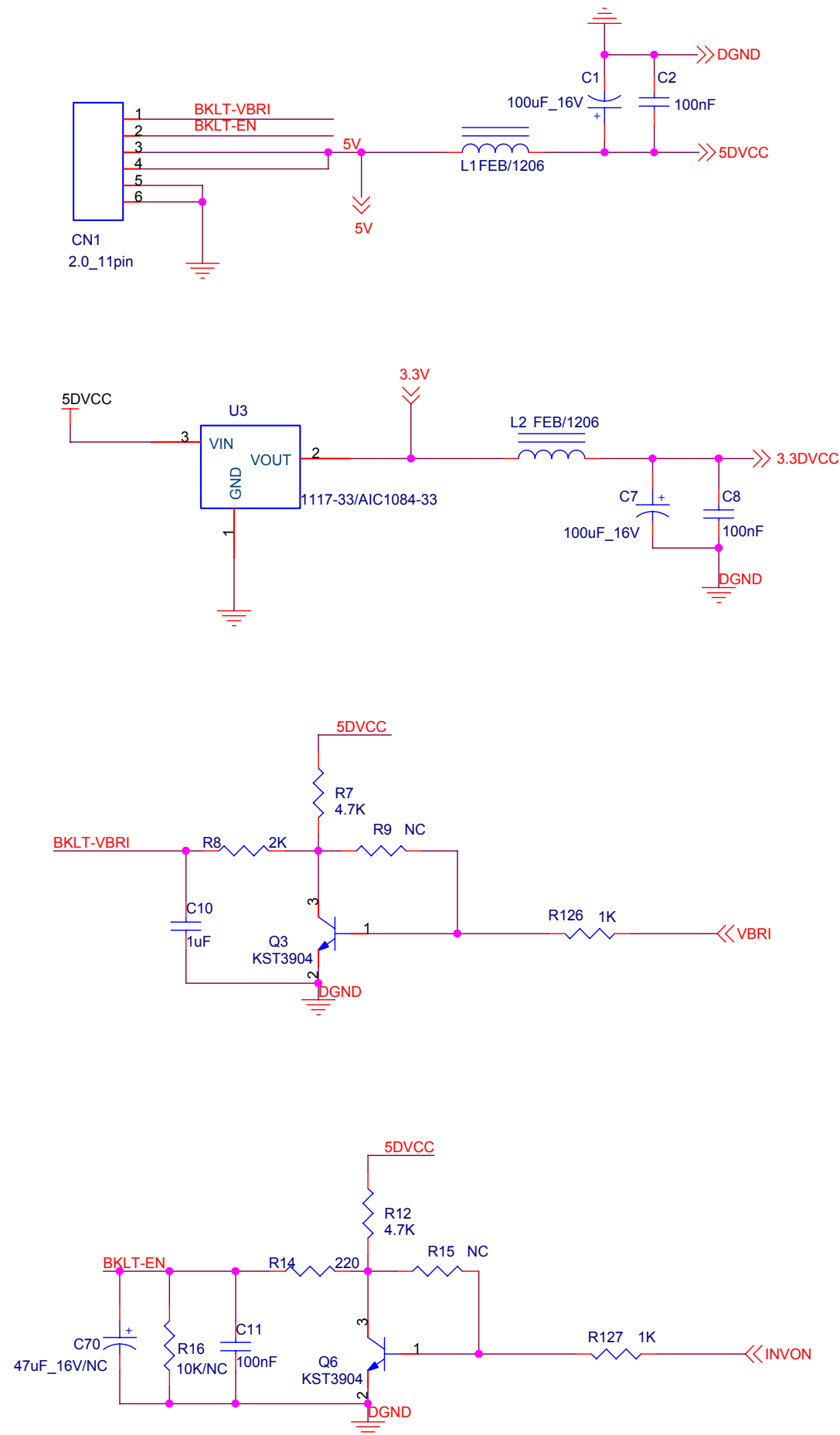

ViewSonic Corporation	
Model	
Title	
Date	Rev:

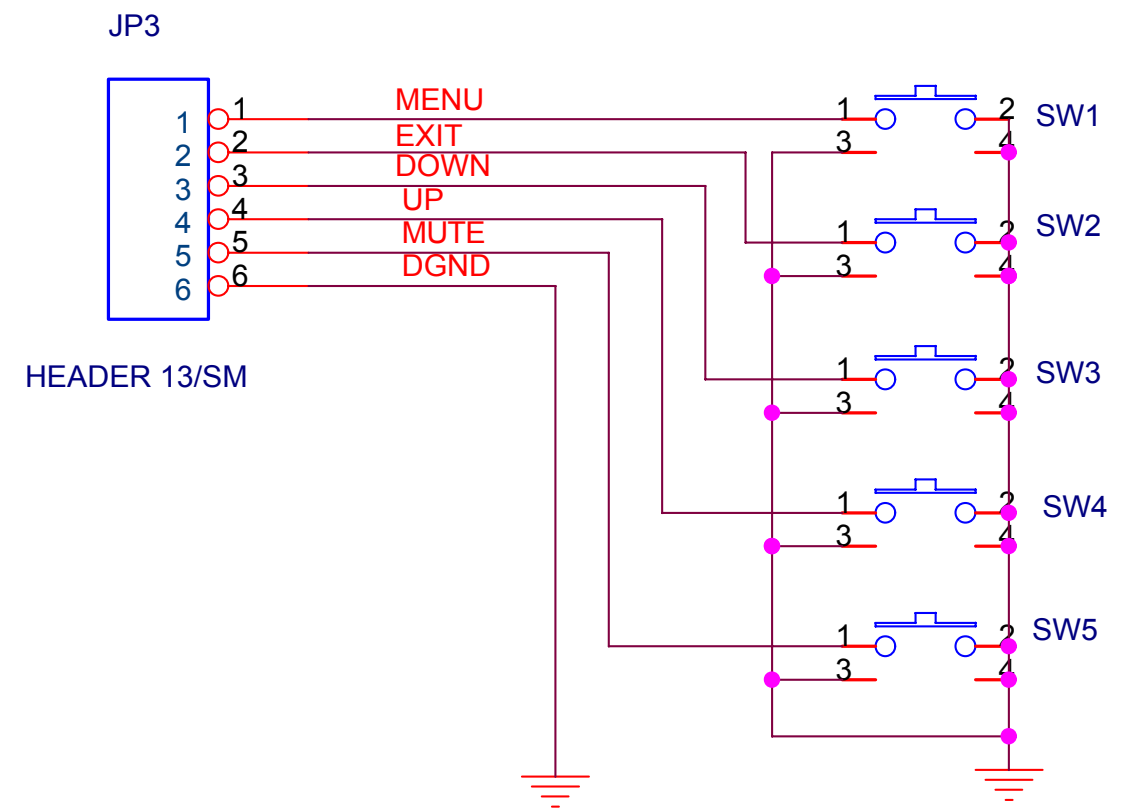
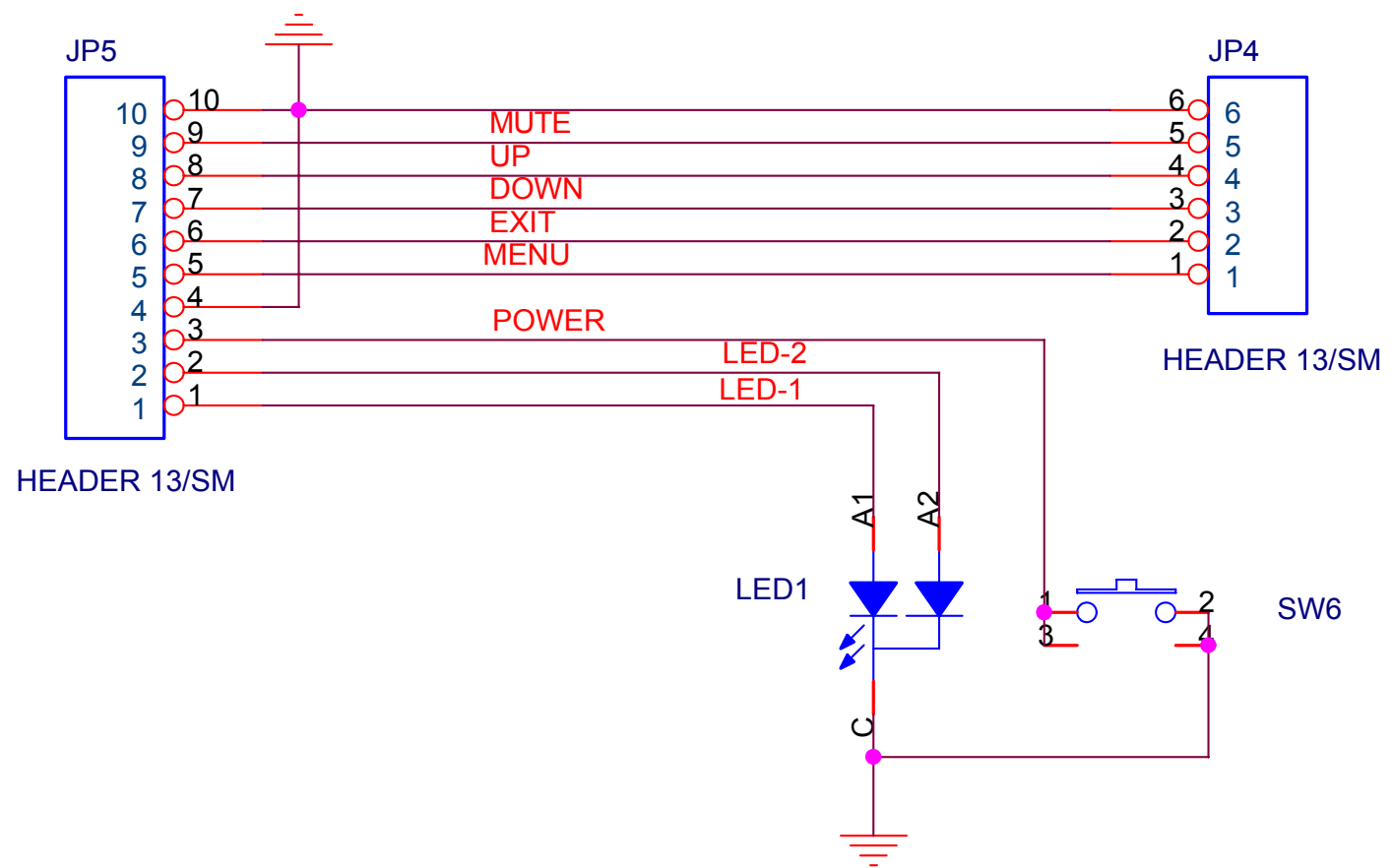

ViewSonic Corporation	
Model	
Title	
Date	Rev:

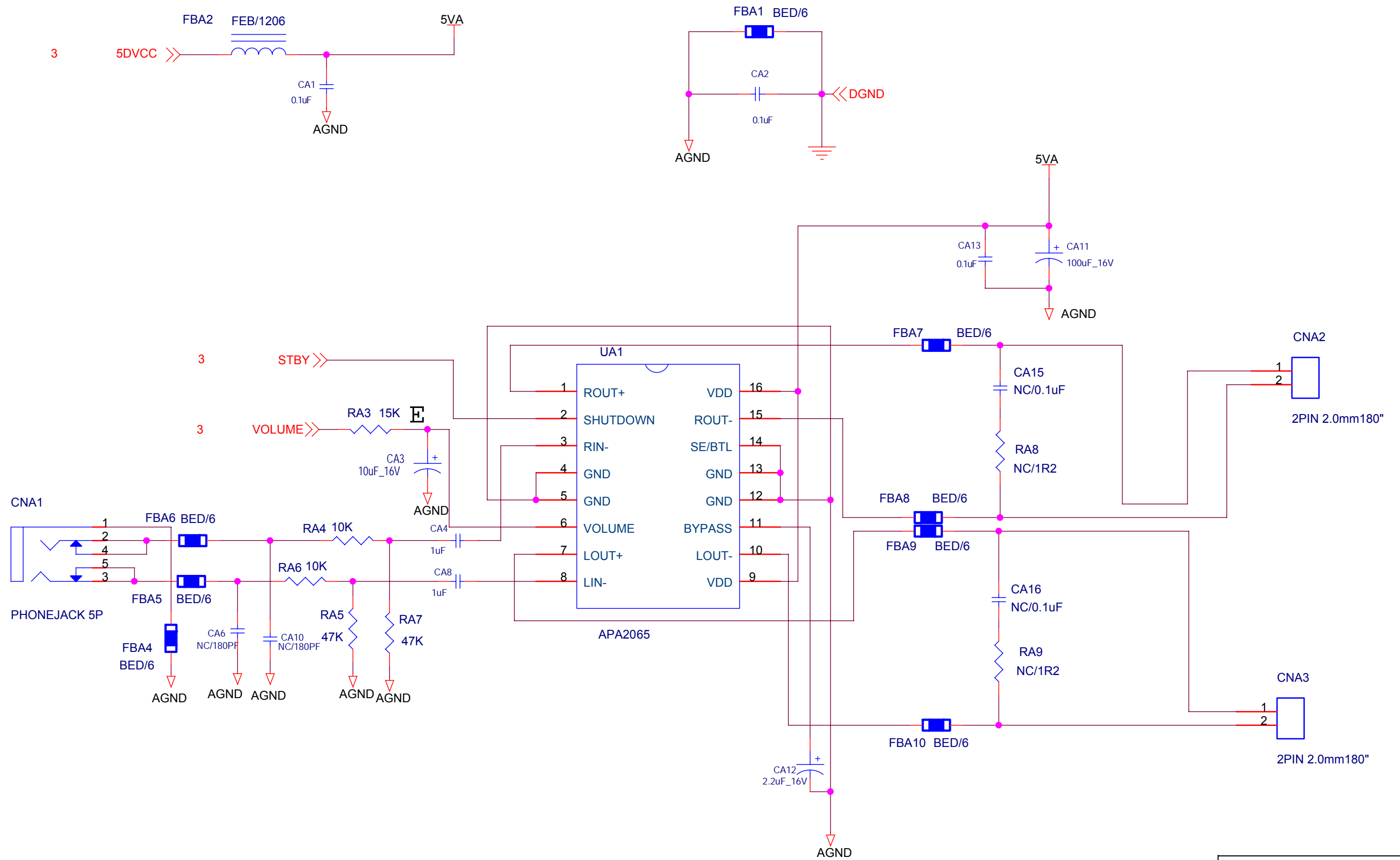

ViewSonic Corporation	
Model	
Title	
Date	Rev:

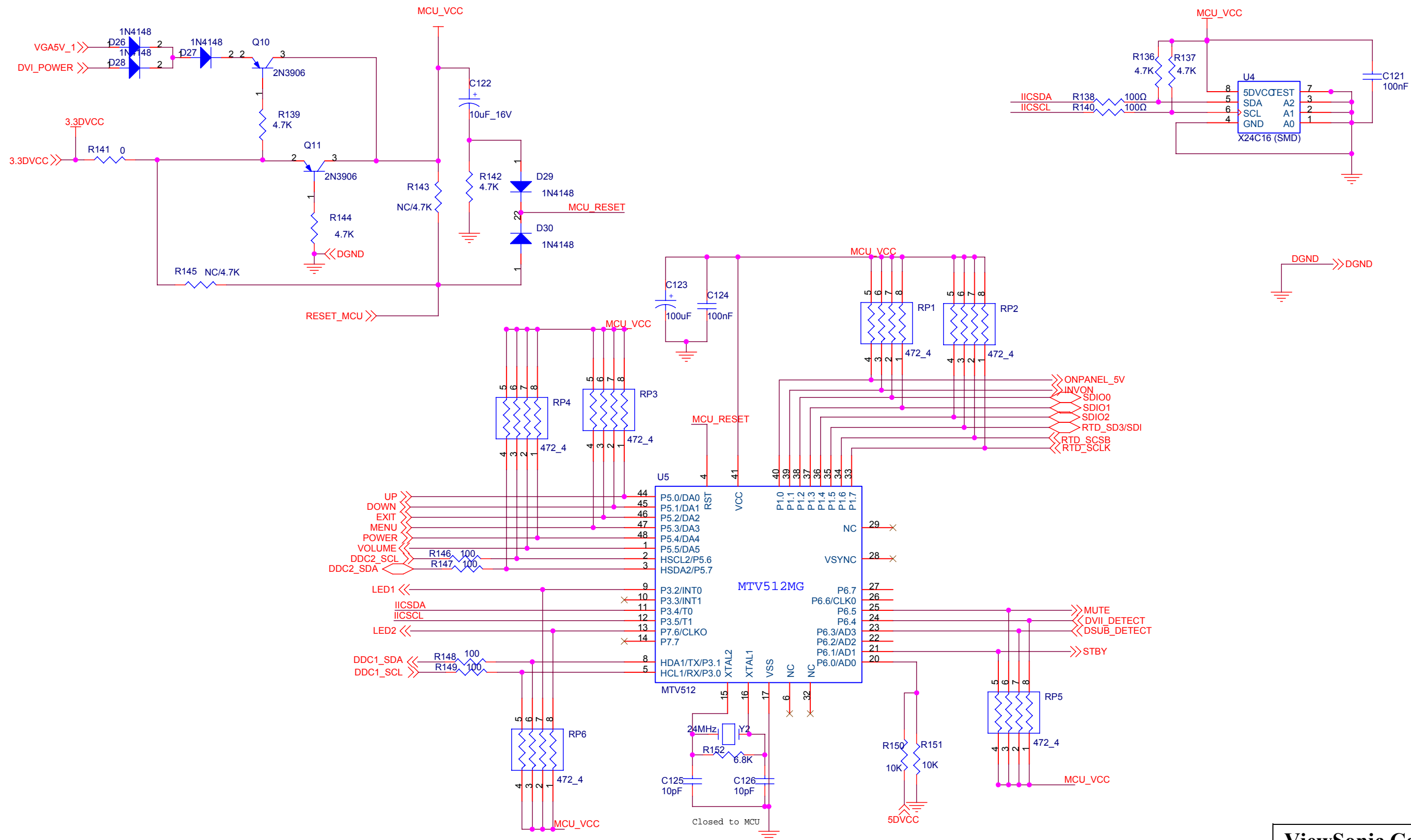

ViewSonic Corporation	
Model	
Title	
Date	Rev:

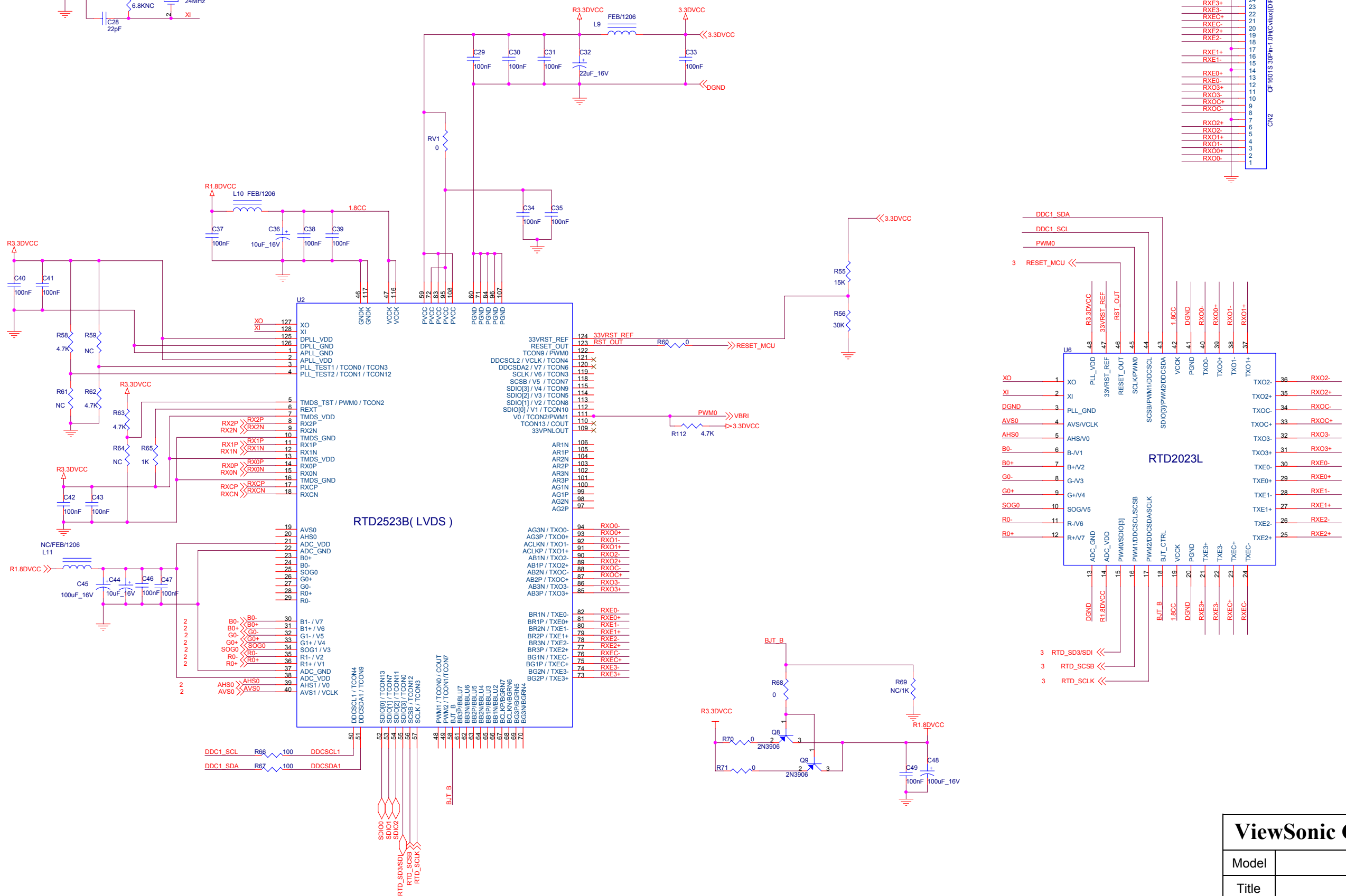
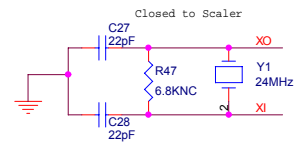

ViewSonic Corporation

Model	
Title	
Date	Rev:

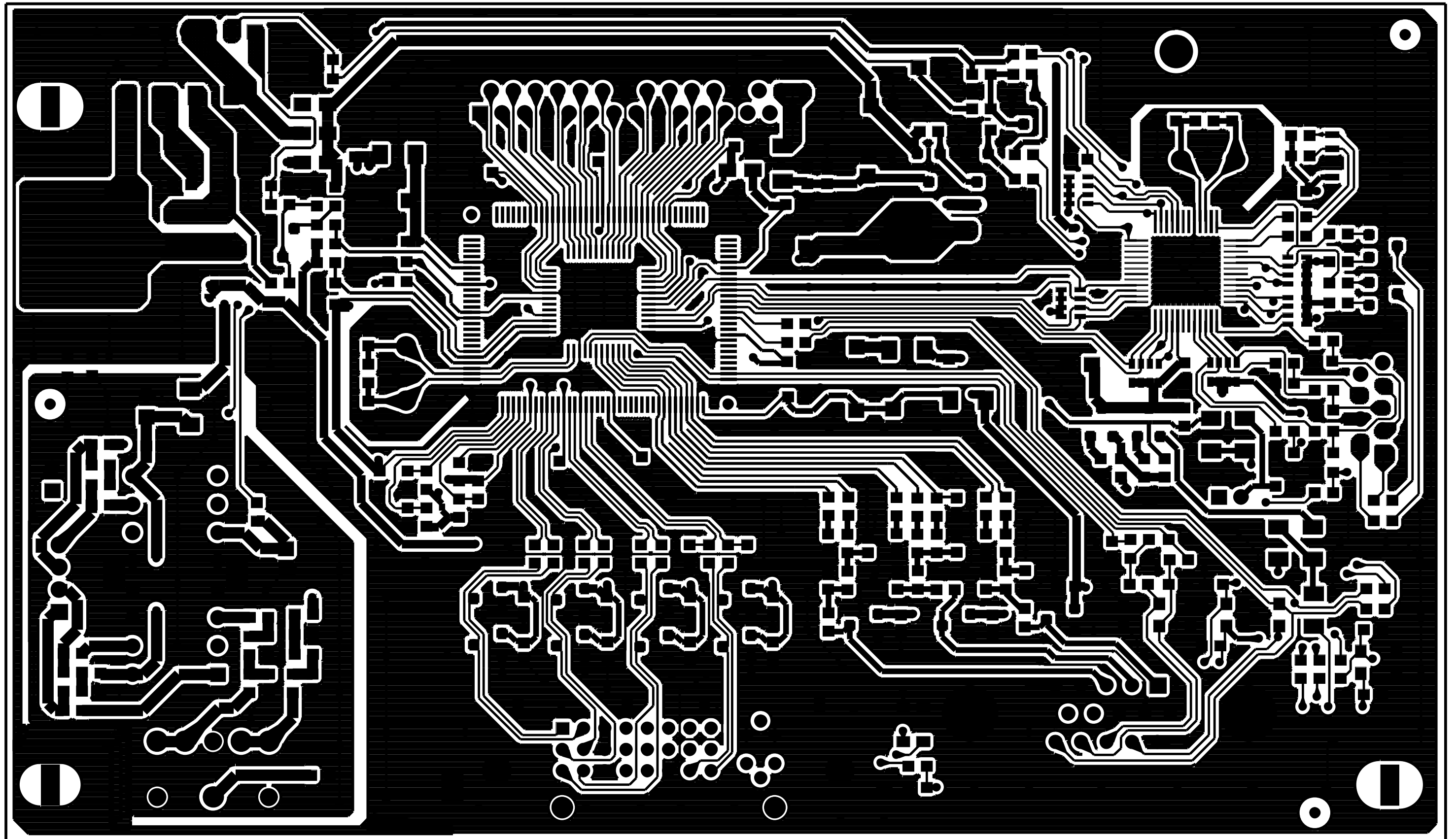

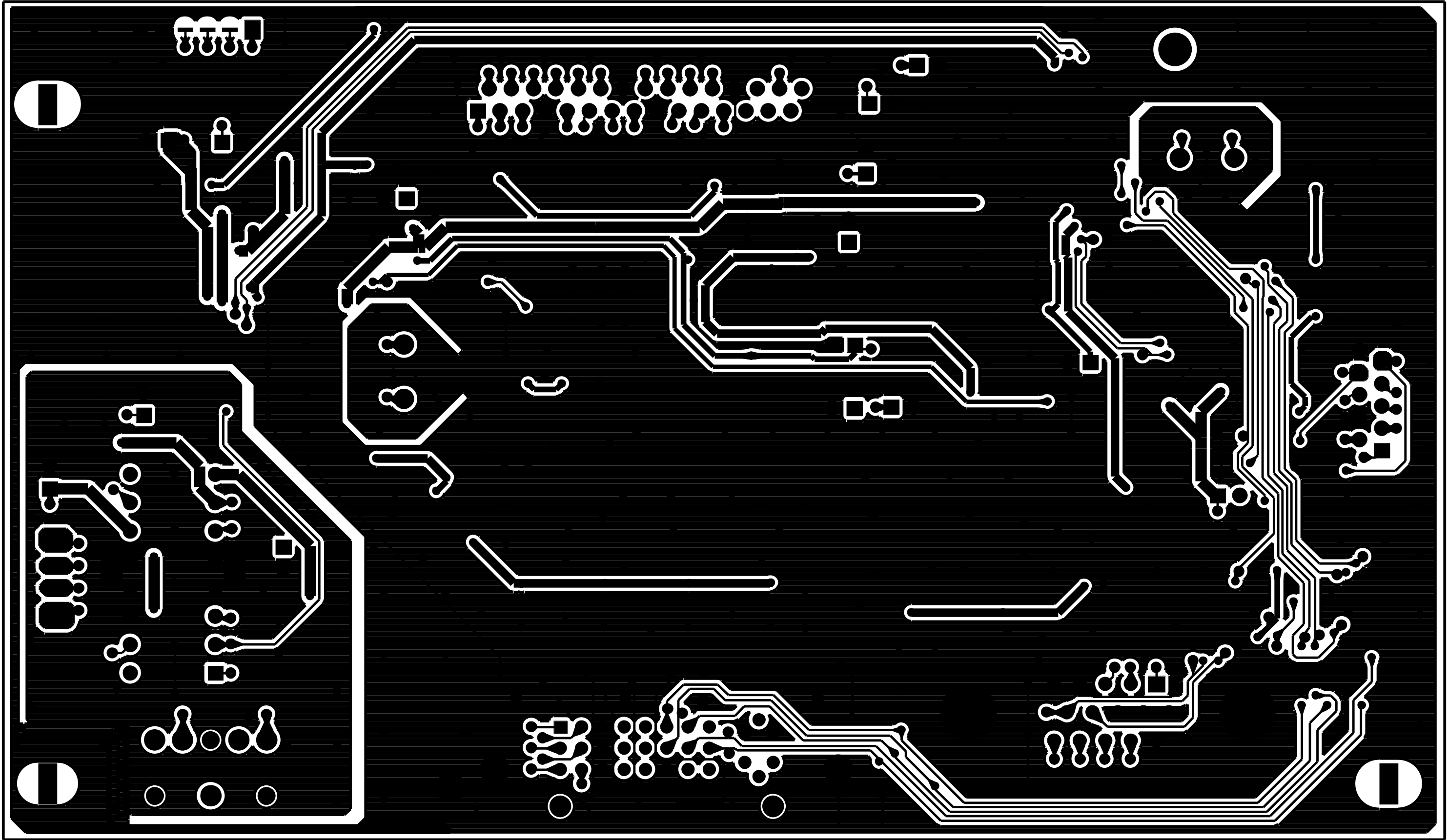

Model:MB-R2523B-DLA1 REV:1.6
P/N:BLM19VAM10116 2006\07\22

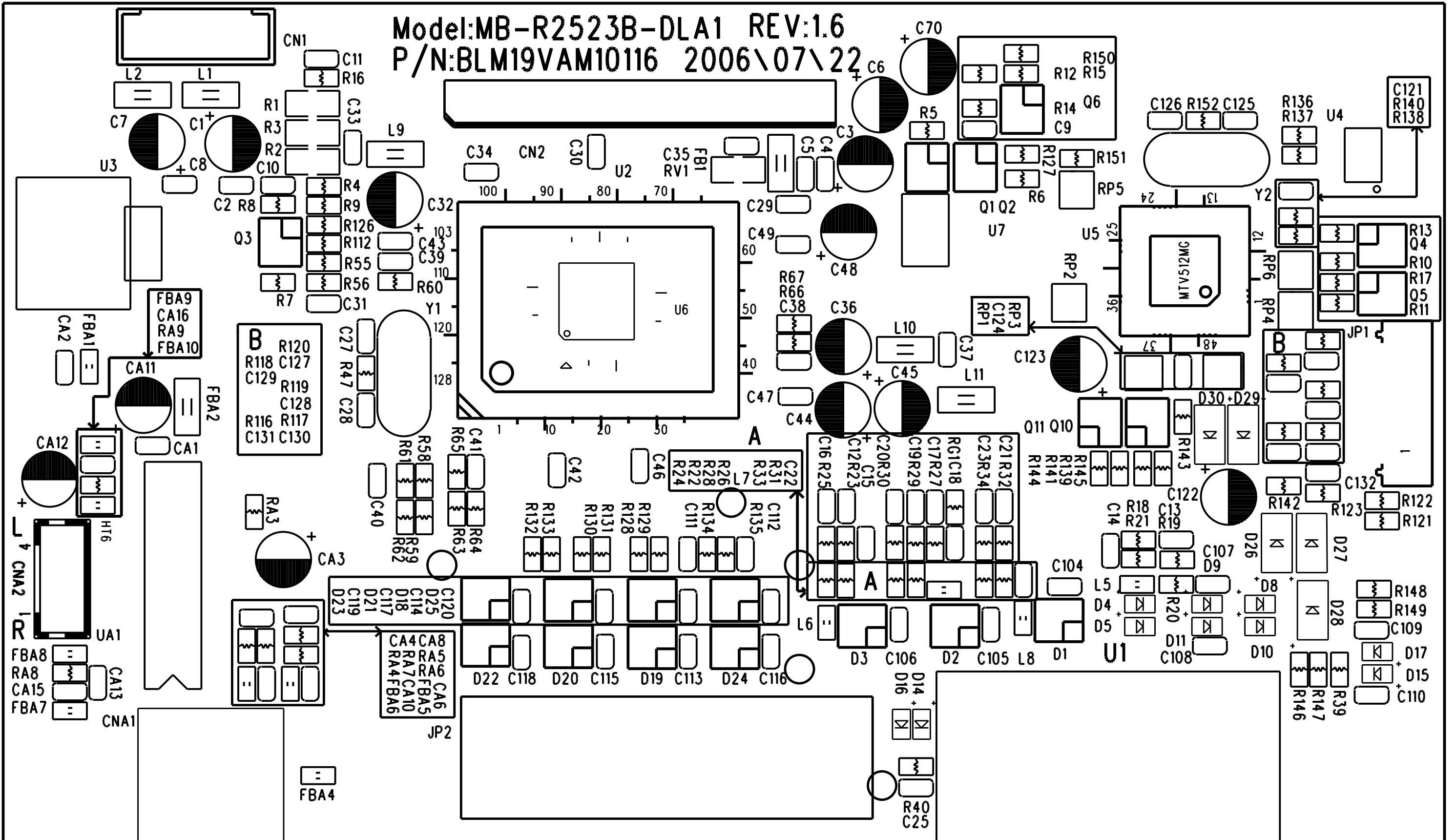

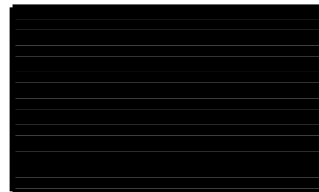
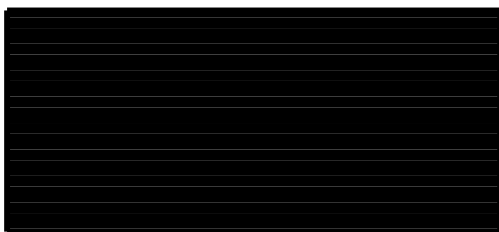
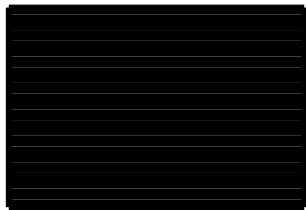
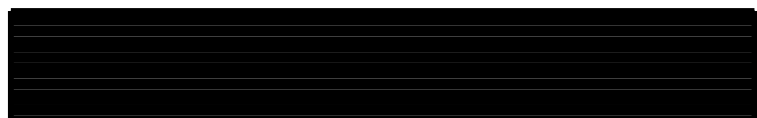
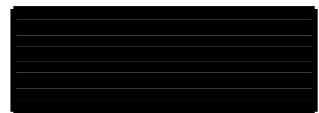

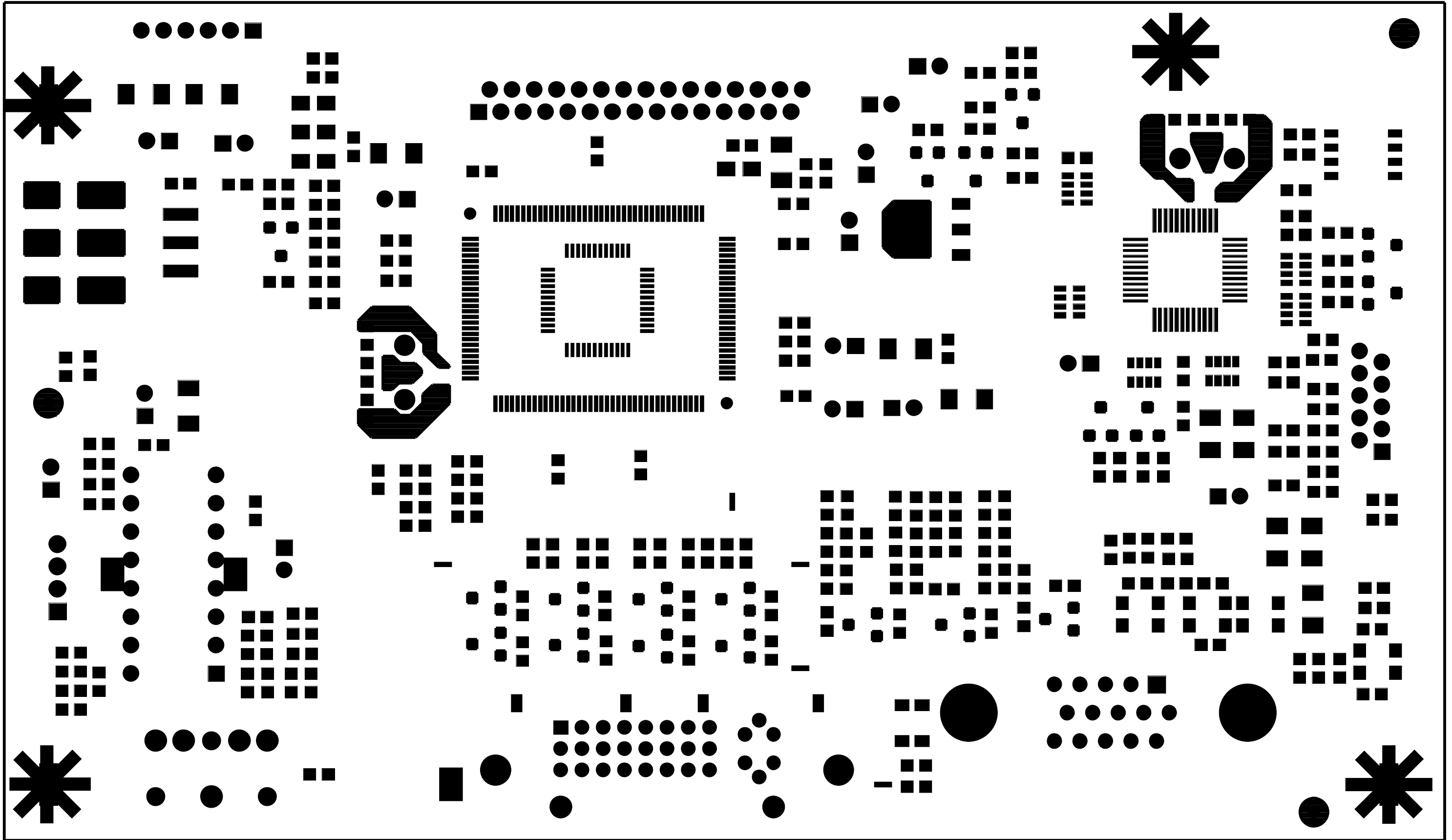

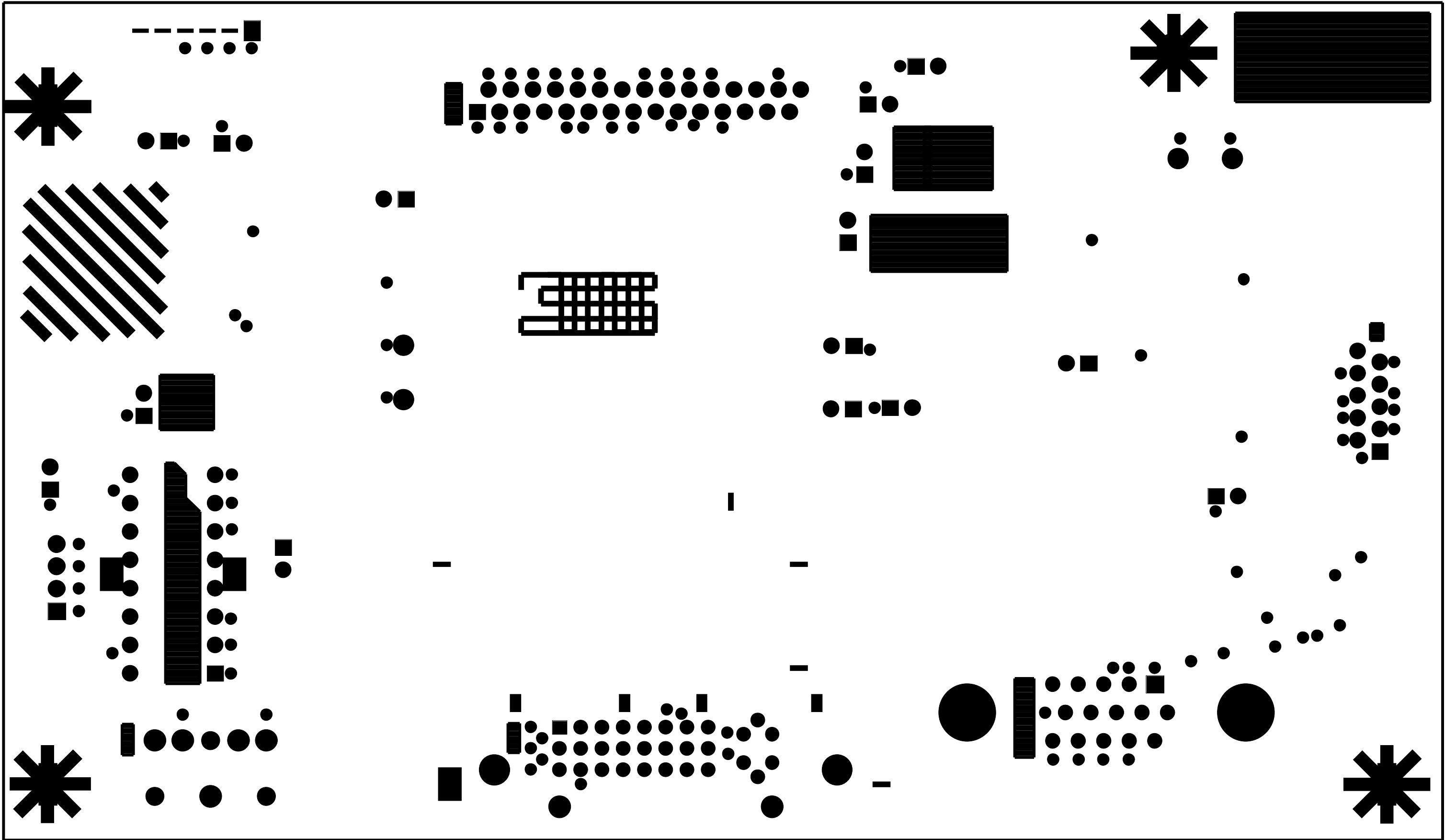

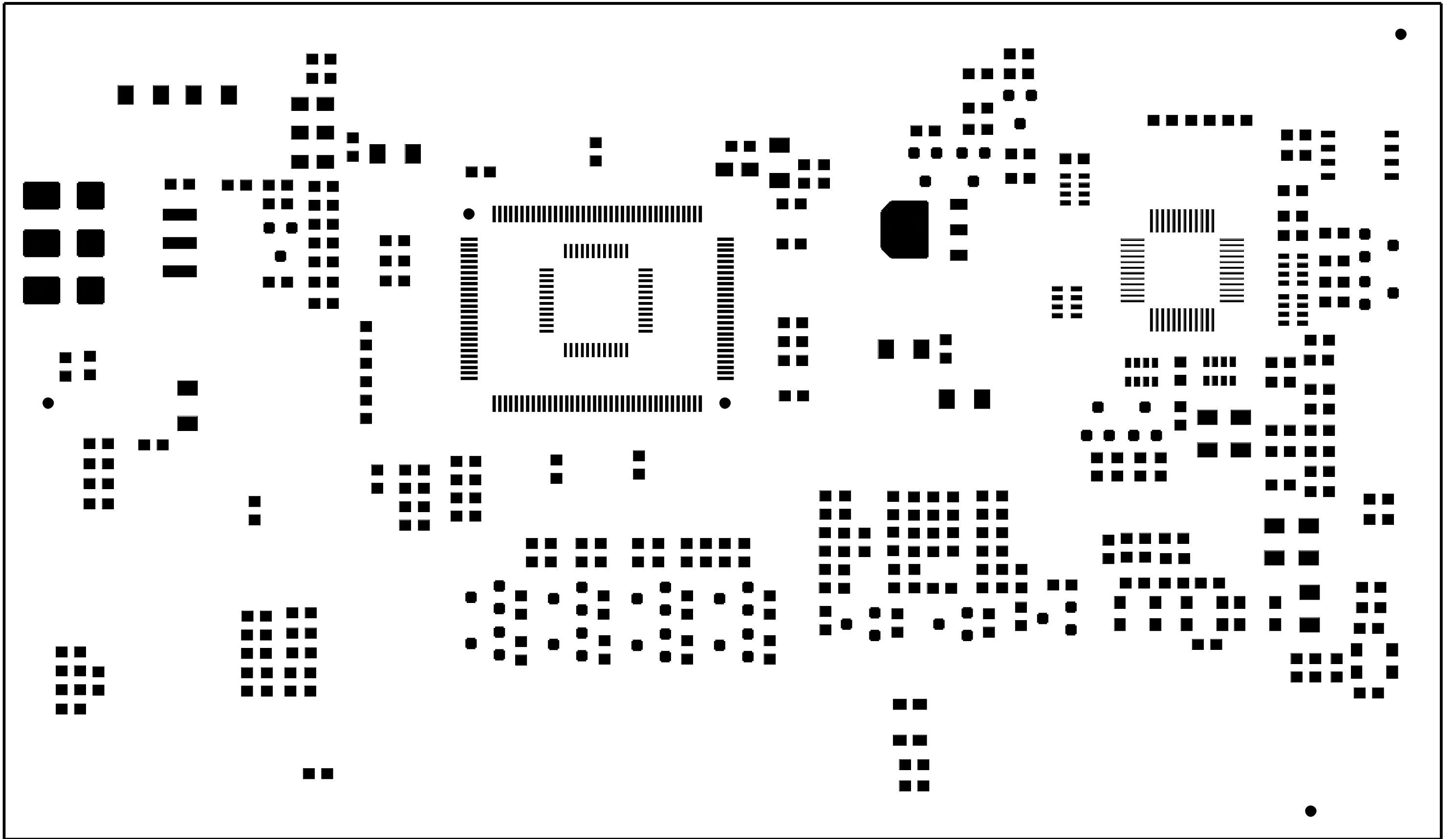

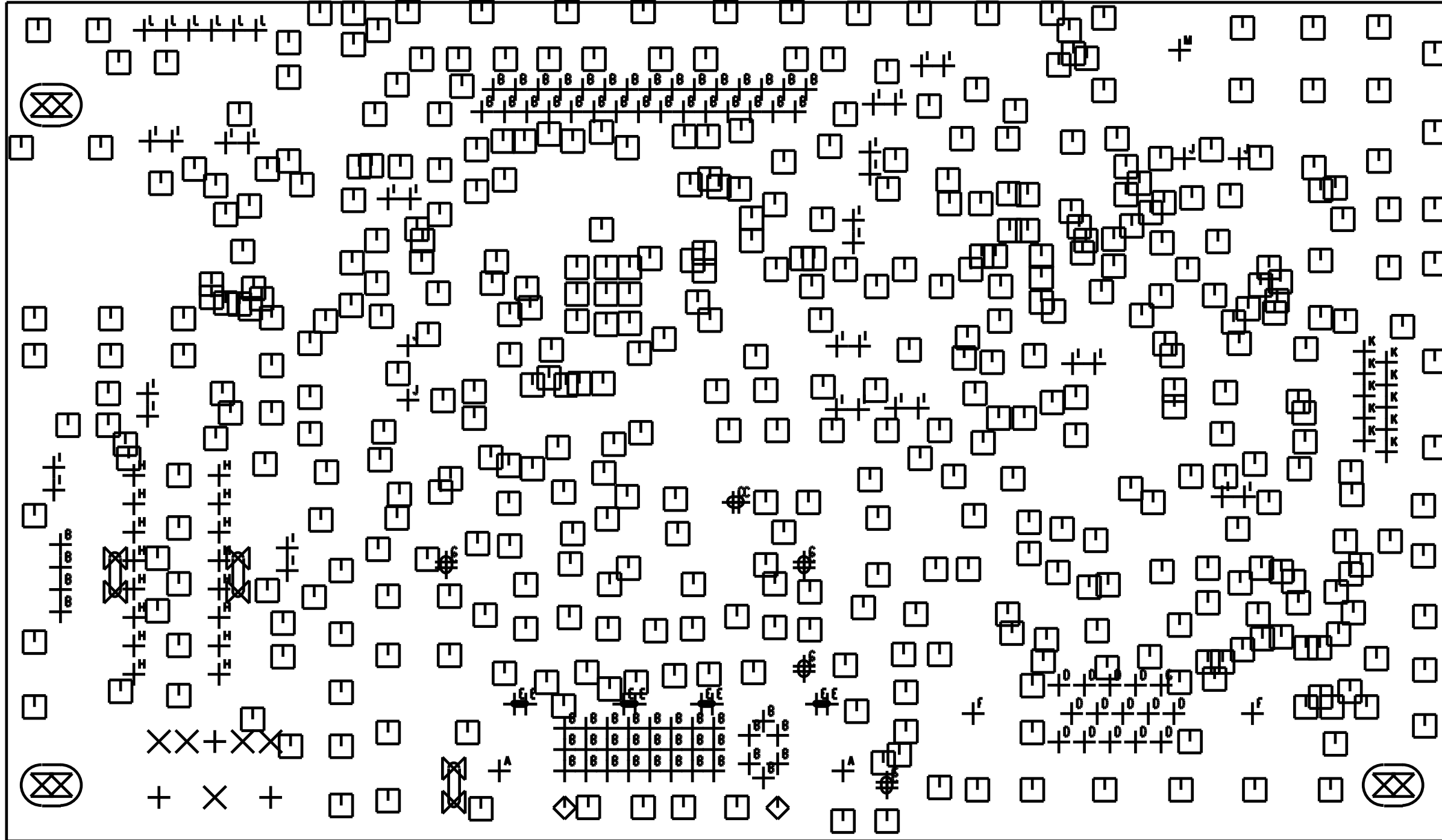

SIZE	QTY	SYM	PLTD	TOL
16	457	□	YES	+/-0.06MM
19.69 x 59.06	4	+ ^L	YES	+/-0.06MM
27.56	10	+ ^K	YES	+/-0.06MM
28	30	+ ^L	YES	+/-0.06MM
31.5	64	+ ^B	YES	+/-0.06MM
31.5	6	+ ^L	YES	+/-0.06MM
35.43	16	+ ^M	YES	+/-0.06MM
35.43	14	+ ^O	YES	+/-0.06MM
39	1	+ ^C	YES	+/-0.06MM
39.37 x 157.48	3	⊗	YES	+/-0.06MM
39.37 x 59.06	5	+ ^C	YES	+/-0.06MM
40	4	+ ^L	YES	+/-0.06MM
50	5	⊗	YES	+/-0.06MM
62.99	3	+	NO	+/-0.06MM
76	2	◇	NO	+/-0.06MM
76	2	+ ^A	YES	+/-0.06MM
126	2	+ ^L	YES	+/-0.06MM
137.8	1	+ ^M	YES	+/-0.06MM
145.67 x 212.6	3	⊗	YES	+/-0.06MM

* *Reader's Response* *

Dear Readers:

Thank you in advance for your feedback on our Service Manual, which allows continuous improvement of our products. We would appreciate your completion of the Assessment Matrix below, for return to ViewSonic Corporation.

Assessment

A. What do you think about the content of this Service Manual?

<i>Unit</i>	<i>Excellent</i>	<i>Good</i>	<i>Fair</i>	<i>Bad</i>
1. Precautions and Safety Notices				
2. Specification				
3. Front Panel Function Control Description				
4. Circuit Description				
5. Adjustment Procedure				
6. Troubleshooting Flow Chart				
7. Recommended Spare Parts List				
8. Exploded Diagram and Exploded Parts List				
9. Block Diagrams				
10. Schematic Diagrams				
11. PCB Layout Diagrams				

B. Are you satisfied with this Service Manual?

<i>Item</i>	<i>Excellent</i>	<i>Good</i>	<i>Fair</i>	<i>Bad</i>
1. Service Manual Content				
2. Service Manual Layout				
3. The form and listing				

C. Do you have any other opinions or suggestions regarding this service manual?

Reader's basic data:

Name:		Title:	
Company:			
Add:			
Tel:		Fax:	
E-mail:			

After completing this form, please return it to ViewSonic Quality Assurance in the USA at facsimile 1-909-839-7943. You may also e-mail any suggestions to the Director, Quality Systems & Processes (marc.maupin@viewsonic.com)