

# Service Manual

## ViewSonic G90f Model No. VCDTS21873-1

**19" Digital Controlled Color Monitor  
(18" Viewable)**



(G90f\_SM\_151 - Rev. 1.0 - October 2000)

# TABLE OF CONTENTS

1. PRECAUTIONS AND SAFETY NOTICES.....	1~2
2. SPECIFICATIONS.....	3~20
3. OSD FUNCTIONS .....	21~27
4. CIRCUIT DIAGRAMS AND WAVEFORMS .....	28~43
5. CIRCUIT DESCRIPTION.....	44~51
6. ADJUSTMENT PROCEDURE.....	52~61
7. TROUBLESHOOTING FLOW CHART .....	62~68
8. MECHANICAL ASSEMBLY .....	69~86
9. EXPLODED PARTS VIEW AND PARTS LIST .....	87~89
10. PCB LAYOUT DIAGRAMS .....	90~92
11. RECOMMENDED SPARE PARTS LIST .....	93~94



## **WARNING**

This service information is designed for experienced repair technicians only and is not designed for use by the general public.

It does not contain warnings or cautions to advise non-technical individuals of potential dangers in attempting to service a product.

Products powered by electricity should be serviced or repaired only by experienced professional technicians.

Any attempt to service or repair the product or products dealt within this service information by anyone else could result in serious injury or death.

## SAFETY PRECAUTIONS

### 1 CAUTION

No modification of any circuit should be attempted. Service work should only be performed after you are thoroughly familiar with all of the following safety checks and servicing guide lines.

### 2 SAFETY CHECK

Care should be taken while servicing this CRT display because of the high voltage used in the deflection circuits. These voltages are exposed in such areas as the associated flyback and yoke circuits.

### 3 FIRE & SHOCK HAZARD

3-1 Insert an isolation transformer between the CRT display and AC power line before servicing the chassis.

3-2 In servicing pay attention to original lead dress especially in the high voltage circuit. If a short circuit is found, replace all parts which have been overheated as a result of the short circuit.

3-3 All the protective devices must be reinstalled per original design.

3-4 Soldering must be inspected for possible cold solder joints, frayed leads, damaged insulation, solder splashes or sharp solder points. Be certain to remove all foreign material.

### 4 LEAKAGE CURRENT COLD CHECK

4-1 Unplug the AC cord and connect a jumper between the two prongs on the plug.

4-2 Turn the CRT display power switch "on".

4-3 Measure the resistance value with an ohmmeter between the jumpered AC plug and each exposed metallic part on the CRT display such as the metal frame, screwheads, control shafts, etc. When the exposed metallic part has a return path to the chassis, the reading should be 1.8 megohm minimum.

### 5 LEAKAGE CURRENT HOT CHECK

5-1 Plug the AC cord directly into the AC outlet. Do not use an isolation transformer during this check.

5-2 Connect a 1500 ohm, 10 watt resistor, paralleled by a 0.15uF capacitor between each exposed metallic part and a good earth ground (as shown in Fig.1).

5-3 Use an AC voltmeter with 1000 ohm/volt or more sensitivity and measure the AC voltage across the combination 1500 ohm resistor and 0.15uF capacitor.

5-4 Move the resistor connection to each exposed metallic part and measure the voltage.

5-5 Reverse the polarity of the AC plug in the AC outlet and repeat the above measurement.

5-6 Voltage measured must not exceed 7.5 volt RMS, from any exposed metallic part to ground. A leakage current tester may be used in the above hot check, in which case any current measured must not exceed 5.0 milliamp. In the case of a measurement exceeding the 5.0 milliamp value, a rework is required to eliminate the chance of shock hazard.

*Note: High voltage is present when this CRT display is operating. Always discharge the anode of the picture tube to the display chassis to prevent shock hazard.*

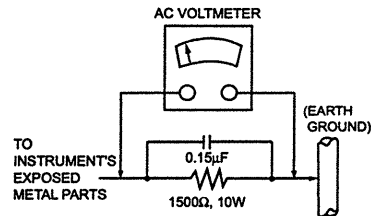

Fig. 1

### 6 IMPLOSION PROTECTION

Picture tubes are equipped with an integral implosion protection system, but care should be taken to avoid damage and scratching during installation.

### 7 X-RADIATION

**WARNING :** The only potential source of X-Radiation is the picture tube. However when the high voltage circuit is operating properly there is no possibility of X-Radiation problem. The basic precaution which must be exercised is to keep the high voltage at the following factory- recommended level.

*Note: It is important to use an accurate periodically calibrated high voltage meter.*

If high voltage cannot be set to 24kV, immediate service is required to prevent the possibility of premature component failure.

To prevent X-Radiation possibility it is essential to use the specified picture tube.

### IMPORTANT SAFETY NOTICE

There are special components used in this CRT displays which are important for safety. These parts are identified by the international symbol  on the schematic diagram and on the replacement parts list. It is essential that these critical parts should be replaced with manufacture's specified parts to prevent X-RADIATION, shock, fire, or other hazards. Do not modify the original design or this will void the original parts and labor guarantee.

	Page
<b>1. Scope -----</b>	<b>05</b>
1.1 Scope -----	05
1.2 Product configuration / Magnetic requirements-----	05
<b>2. Input requirements -----</b>	<b>06</b>
2.1 AC power supply-----	06
2.2 Video interface -----	06
2.3 Scanning frequency-----	06
<b>3. Adjustment control-----</b>	<b>07</b>
3.1 User control-----	07
3.2 OSD adjustment function -----	07
3.3 LED indication -----	07
<b>4. Electrical specification-----</b>	<b>08</b>
A. Electrical specification-----	08
4.1 Standard condition of measurement-----	08
4.2 CRT specification -----	08
4.3 Power saving-----	08
B. Screen characteristics -----	08
4.4 Picture display size-----	08
4.5 Picture center -----	08
4.6 Linearity-----	09
4.7 Picture distortion-----	09
4.8 Misconvergence-----	10
4.9 Focus-----	10
4.10 Jitters -----	10
4.11 White balance-----	10
4.12 Light output-----	11
4.13 Brightness uniformity-----	11
4.14 Size regulation-----	11
<b>5. Environmental condition-----</b>	<b>12</b>
5.1 Temp and humidity at operation-----	12
5.2 Temp and humidity at storage-----	12
5.3 Vibration test (packaged)-----	12
5.4 Drop test (packaged)-----	12
5.5 Altitude-----	12

INDEX

	Page
<b>6. Physical specification-----</b>	<b>12</b>
6.1 Dimension -----	12
6.2 Mechanical adjustment-----	12
6.3 Packaging -----	12
<b>7. Manuals and documentation-----</b>	<b>13</b>
7.1 Inserted materials -----	13
<b>8. Regulatory and Safety-----</b>	<b>13</b>
8.1 North America-----	13
8.2 International-----	13
8.3 Power management -----	13
<b>9. Video communications-----</b>	<b>13</b>
9.1 EDID standard and structure-----	13
9.2 EDID vendor name-----	13
9.3 EDID product ID-----	13
9.4 EDID established timing-----	13
9.5 Approvals-----	13
9.6 USB(Optional)-----	13
<b>10. Coding assignment-----</b>	<b>14</b>
10.1 Product name and Model number-----	14
10.2 Serial number format-----	14
10.3 Regional product ID code-----	14
10.4 UPC coding-----	14
10.5 FCC ID code-----	14
<b>Appendix A : Factory preset timings-----</b>	<b>15</b>
Timing char : G90f/A90-2-----	16
<b>Appendix B : DDC contents-----</b>	<b>18</b>
<b>DDC contents for G90f-----</b>	<b>18</b>
<b>DDC contents for A90-2-----</b>	<b>21</b>

1. Scope.

1.1 This specification defines the configuration and performance requirements for the ViewSonic corporation G90f family of computer monitor.

1.2 Product configuration/Magnetic requirements  
G90f

Model number	Location	Magnetic requirement
VCDTS21873-1M	North America	Bh=250mG±10mG,Bv=490mG±10mG
VCDTS21873-1E	Europe	Bh=+/-250mG±10mG,Bv=490mG±10mG
VCDTS21873-1A	Australia	Bh=+/-270mG±10mG,Bv=-570mG±10mG
VCDTS21873-1P	Pacific	Bh=+/-250mG±10mG,Bv=490mG±10mG
VCDTS21873-1J	Japan	Bh=250mG±10mG,Bv=450mG±10mG

2. Input requirements.

2.1 AC power supply.

- 2.1.1 Power source : 90~264VAC, 50/60Hz.
- 2.1.2 Power consumption : Less than 130W (G90f/ ).
- 2.1.3 Inrush current : Less than 40Ao-p for 1/2 cycle on cold starting.
- 2.1.4 Input current : 3A max.
- 2.1.5 Leakage current : 0.75mA at AC 100V/240V.
- 2.1.6 Ripple / noise : Should not cause any visible interference.
- 2.1.7 Power cable / color : 1.83 meter / match with cabinet.  
 (R) M model : 3-prong NEMA 5-1 5P type plug  
 E model : Shuko CEE7-7  
 P model : PC type and US Wall  
 A model : ASA (Australia) and PC type  
 J model : T-mark

2.2 Video interface.

- 2.2.1 RGB video : Analog, 0.7Vp-p, positive, input impedance 75ohm.
- 2.2.2 Max PC video signal : 950mV with no damage to monitor.
- 2.2.3 Max MAC video signal : 1250mV with no damage to monitor.
- 2.2.4 Sync signal : Separate or composite horizontal and vertical sync (TTL level).
- 2.2.5 Signal cable / color : 1.83 meter ivory PC99 / match with cabinet.
- 2.2.5 Input connector :

15 pin mini "D" sub :

Pin No.	Signal	Pin No.	Signal
1	Red	9	5V (G90f)
2	Green	10	Ground
3	Blue	11	Ground
4	Ground	12	SDA
5	Ground	13	H. Sync
6	R Return	14	V. Sync
7	G Return	15	SCL
8	B Return		

- 2.2.6 Signal memory modes : 13 preset modes(G90f/ )  
 18 user modes, see **Appendix A.**
- 2.2.7 Plug & play : VESA DDC1 / 2B, DDC data **Appendix B.**
- 2.2.8 Input signal timing compatibility : VESA GTF

2.3 Scanning frequency.

- 2.3.1 Horizontal : 30KHz to 97KHz -> G90f
- 2.3.2 Vertical : 50Hz to 180Hz -> G90f



3. Adjustment control

3.1 User control.

3.1.1 Power switch.

3.1.2 OSD key.

1 : Function select button.

▽ : Adjustment button.

△ : Adjustment button.

2 : Function select button.

3.2 OSD adjustment function.

- a. Contrast / Brightness.
- b. H. size / Position.
- c. V. Size / Position.
- d. Pincushion / Balance.
- e. Trapezoid / Parallel.
- f. Top / Bottom Hook
- g. Tilt.
- h. H / V Moire
- i. H / V Focus
- j. Input level
- h. Degauss.
- i. Viewmeter.
- j. Viewmatch color : 9300°K / 6500°K / 5000°K User (R, G, B).
- k. Language.
- l. Memory recall.

3.3 LED indication.

Status		LED	
Power on	Normal	Green	
	Power saving	Stand-by Suspend Off mode	Orange
	Over range frequency		Orange
Power off		Off	

4. Electrical specification.

A. Electrical specification.

- 4.1 Standard condition of measurement.
  - 4.1.1 Brightness – 50% factory shipment condition.
  - 4.1.2 Contrast – 100% factory shipment condition (MAX).
  - 4.1.3 Preset color – 9300°K.
  - 4.1.4 Brightness 30FL (Full white).
  - 4.1.5 Warm up time – Start testing 30 minutes or more after power on.
  - 4.1.6 Timing chart – Refer to **Appendix A**.

4.2 CRT specification.

Item	Spec
CRT	HITACHI:M46LSQ183X01(W) (G90f)
Size	19 inch
Diagonal(Viewable area)	18 inch
Mask type	Shadow Mask
Pitch	0.25mm(G90f)
Faceplate treatment	AGAS
Transmission percentage	45%(G90f)

4.3 Power saving.

4.3.1 Power saving.

Status	Horizontal Sync.	Vertical Sync.	Power consumption	Power LED	Recovery time
Normal	Yes	Yes	< 130W(G90f)	Green	N/A
Stand-by	No	Yes	< 15W	Orange	< 3 sec
Suspend	Yes	No	< 15W	Orange	< 3 sec
Off	No	No	< 3W	Orange	< 10 sec

B. Screen characteristics.

4.4 Picture display size.

Horizontal size : 357± 4mm (primary mode) / 357± 5mm (other mode).

Vertical size : 268± 4mm (primary mode) / 268± 5mm (other mode).

4.5 Picture center.(Correctable to zero)

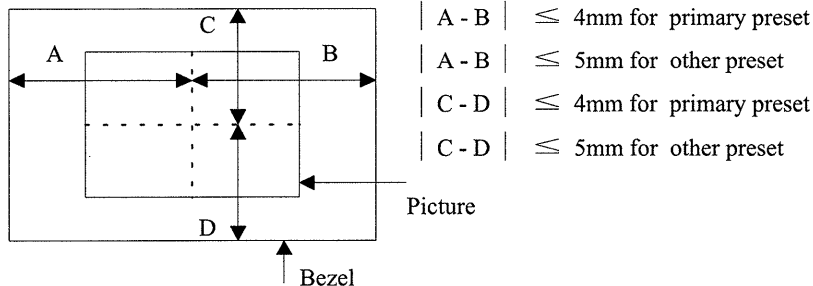

4.6 Linearity.

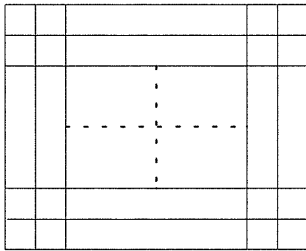

$$\begin{aligned} \text{H-Linearity} & \frac{X_{\max} - X_{\min}}{X_{\max} + X_{\min}} \times 100\% \leq 4\% \\ & \leq 5\% \\ \text{V-Linearity} & \frac{Y_{\max} - Y_{\min}}{Y_{\max} + Y_{\min}} \times 100\% \leq 4\% \\ & \leq 5\% \end{aligned}$$

Input signal : Cross-hatch  
16x12

4.7 Picture distortion.

4.7.1 Trapezoid / Parallelogram / Orthogonality / 2mm Box.

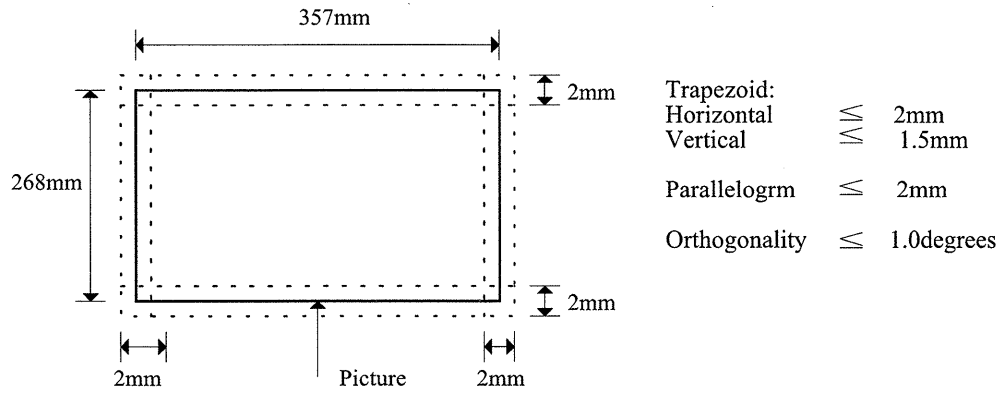

4.7.2 Pincushion / Barrel / Pin-balance.

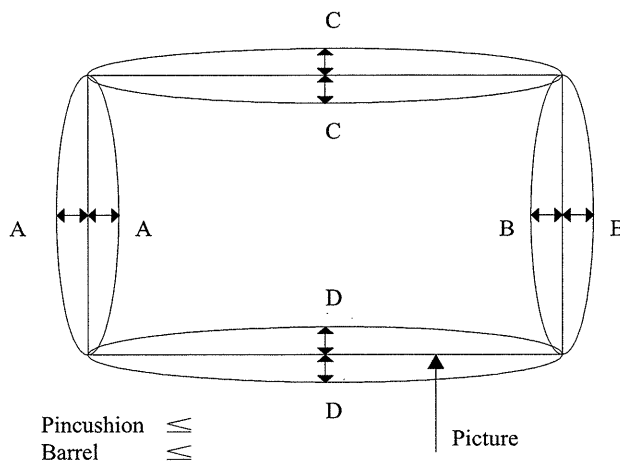

4.7.3 Tilt.(adjustable to zero)

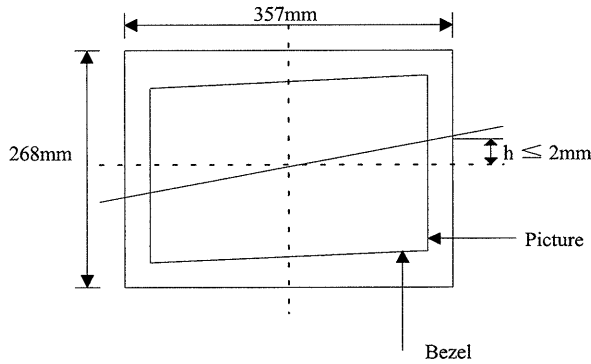

4.8 Misconvergence.

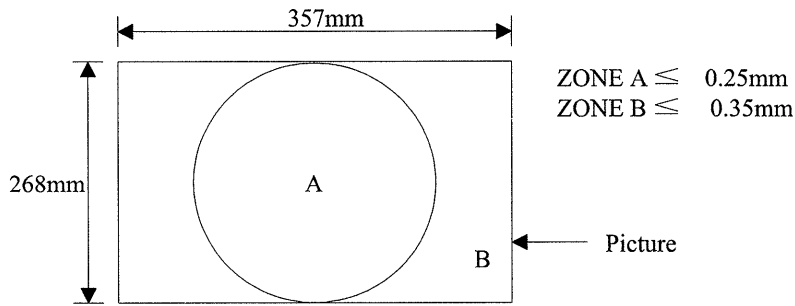

4.9 Focus.

4.9.1 Under the condition of brightness center and contrast maximum “mE”, pattern can be seen clearly by using the 1024x768 60K/75Hz. If necessary, limit sample agreed by both parties will be made for final focus judgement.

4.10 Jitters : Less than 0.1mm.

4.11 White balance.

4.11.1 Color temperature : Using the CIE color temperature coordinate system.  
 Color 9300°K :  $x = 0.283 \pm 0.02$ ,  $\Delta u' v' \leq 0.01$   
 $y = 0.297 \pm 0.02$ .  
 Color 6500°K :  $x = 0.313 \pm 0.02$ ,  $\Delta u' v' \leq 0.01$   
 $y = 0.329 \pm 0.02$ .  
 Color 5000°K :  $x = 0.346 \pm 0.02$ ,  $\Delta u' v' \leq 0.01$   
 $y = 0.359 \pm 0.02$ .

4.11.2 Color tracking : When the full white pattern display at preset condition. (only for 9300°K)

$$\begin{aligned} |x_{25.75FL} - x_{10FL}| &\leq 0.007 \\ |x_{25.75FL} - x_{30FL}| &\leq 0.003 \\ |y_{25.75FL} - y_{10FL}| &\leq 0.007 \\ |y_{25.75FL} - y_{30FL}| &\leq 0.003 \end{aligned}$$

4.11.3 Video amplifier linearity, input step :

$$|x_{600\text{mV}} - x_{700\text{mV}}| \leq 0.007.$$

$$|y_{600\text{mV}} - y_{700\text{mV}}| \leq 0.003.$$

4.11.4 Color purity : Impurity should not appear in the pattern of all green, all red, or all white.

4.12 Light output.

4.12.1 At 70mm x 70mm white block pattern :  $40 \pm 4\text{FL}$ .

4.12.2 At full-white pattern :  $30 \pm 2\text{FL}$ .

4.13 Brightness uniformity.

4.13.1 25% deviation maximum between center any eight points within the display picture.

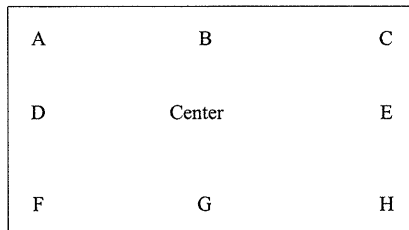

4.14 Image regulation.

4.14.1 Static regulation  $\leq 1\text{mm}$ .

4.14.2 Dynamic regulation  $\leq 1\text{mm}$ .

4.14.3 Temperature and line voltage  $\leq 0.5\%$  of line length.

**5. Environmental conditions.**

- 5.1 Temperature and humidity at operation : 0°C ~40°C.  
5% ~ 95% RH (Non condensing).
- 5.2 Temperature and humidity at storage : -40°C ~ 60°C.  
5 ~ 95% RH (Non condensing).
- 5.3 Vibration test (packaged) :  
Vibration Frequency : 5 ~ 250Hz.  
Acceleration : 1G.  
Sweep time : 1 oct. / min.  
Test time : 60 min per axis.
- 5.4 Drop test (packaged) : 70cm height.  
1 corner, 3 edges, 6 faces.
- 5.5 Altitude :  
Operating : 0 ~ 3000 feet.  
Non-operating : 0 ~ 12000 feet.

**6. Physical specification.**

- 6.1 Dimension.      G90f  
Height              465mm.  
Width                448mm.  
Depth                458.5mm.  
Footprint width    260mm.  
Footprint depth    260mm.  
Monitor weight    22Kg.
- 6.2 Mechanical adjustment.  
Tilt                  - 5 / + 15 degrees.  
Swivel               ± 90 degrees.
- 6.3 Packaging.  
6.3.1 Carton dimension.  
Model                G90f  
Height                508mm.  
Width                 560mm.  
Depth                 580mm.  
6.3.2 Shipping weight :    25Kg.  
6.3.3 Container loading ;    320 units.

**7. Manuals and documentation**

7.1 Inserted materials :

Production sample of the User's Guide ,Rear Label and all other Inserted Materials will be provided to ViewSonic for approval before mass production.

**8. Regulatory and Safety**

8.1 North America

Model name : G90f

UL1950 ; CUL ; DHHS Part 21, Subpart J ; FCC part 15, Subpart J, Subpart B, CE ; CB ; DOC, ICES-003, CLASS B ; NOM (to be applied by ViewSonic).

8.2 International

Model name : G90f

TUV-GS, TUV-ERGO ; TCO99 ; NEMKO, DEMKO, SEMKO, FEMKO ; VCCI ; C-TICK ; S. Africa ; CCIB ; S-Mark ; PCT, SASO, B-MARK ; BSMI ; CCEE.

8.3 Power Management : ENERGY 2000, < 3W off state.

Amendment to EnergyStar Version 2 MOU,dated.

**9. Video communications**

9.1 EDID Standard and Structure

VESA's EDID Standard Version #3, Revision #0, EDID Structure Version #1.3, Revision #1.

9.2 EDID Vendor Name

VSC: Byte 8 – 5Ah, Byte 9 – 63h.(G90f/.

9.3 EDID Product ID

The shall be encoded as an ASCII representation of the first two digits of the North American serial number.

Byte 10 = 10h, Byte 11 = 05h (G90f)

9.4 EDID Established Timing

Shall match with the factory timing settings specified by ViewSonic above in section 6.0.

9.5 Approvals

File contents shall be approved by ViewSonic prior to Mass Production Release.

9.6 USB(Optional)

A High Speed Active (one upstream port and four downstream ports) Hub shall be quoted as an option. The USB cable supplied with the unit shall be two meters long. A Host on Screen Display, based on ViewSonic Screens, compatible with Microsoft Windows 95 "4.00.950 B" and Windows 98, shall be supplied.

## 10. Coding assignment

### 10.1 Product Name and Model Number.

Product Name : View Sonic G90f

North America	Model Number VCDTS21873-1M
Europe	Model Number VCDTS21873-1E
Asia	Model Number VCDTS21873-1P
Australia	Model Number VCDTS21873-1A
Japan	Model Number VCDTS21873-1J

### 10.2 Serial Number Format

PPPYWnnnnn where

PPP	= Regional Product ID Code
YY	= Last digit of manufacturing year
WW	= Manufacturing week
Nnnnn	= Production sequence number (Assigned by factory)

### 10.3 Regional Product ID code

Model name : G90f

North America	ID Code: 30W
Europe	ID Code: 30X
Asia	ID Code: 30Y
Australia	ID Code: 30Z
Japan	ID Code: 310

### 10.4 UPC coding

Model name : G90f

North America	UPC Code: 7 66907 33421 0
Europe	UPC Code: 7 66907 34451 6
Asia	UPC Code: 7 66907 34461 5
Australia	UPC Code: 7 66907 34471 4
Japan	UPC Code: 7 66907 34481 3

### 10.5 FCC ID code

Self-Declared



Appendix A : Factory preset timings.

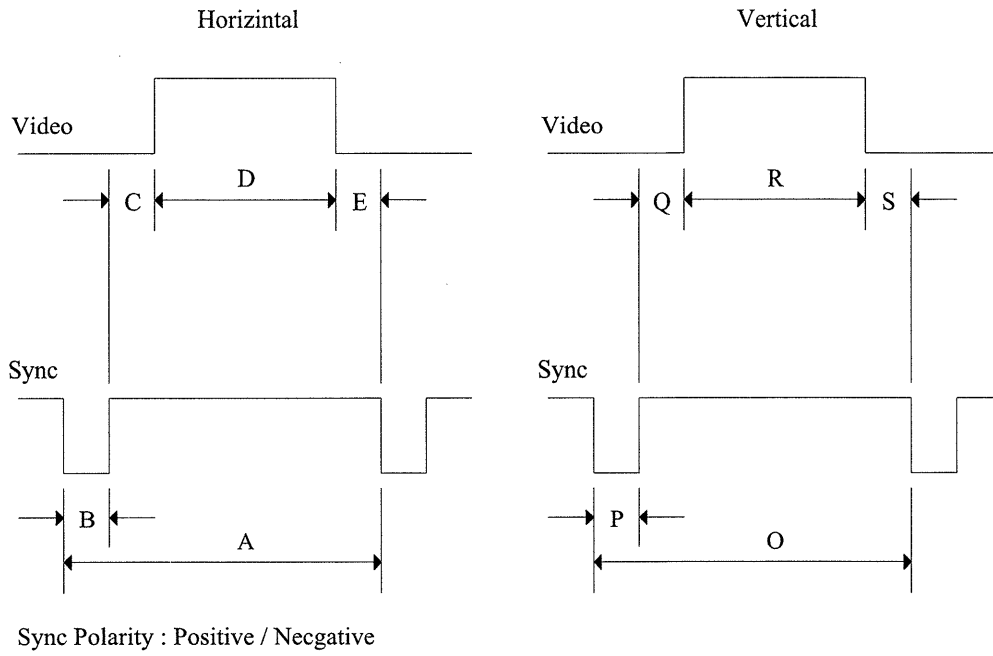

**Timing chart : G90f**

Mode No.	1	2	3	4	5	6	7	8	9	10
Mode Name	VGA 640 x 400	VGA 640 x 480	VGA 640 x 480	VESA 800 x 600	VESA 800 x 600	VESA 1024 x 768	VESA 1024 x 768	VESA 1280 x 1024	VESA 1280x 1024	VESA 1280x 1024
Horizontal Freq. (KHz)	31.469		37.500	46.875	53.674	60.023	68.677	63.981	79.976	91.146
Sync. Polarity	-	-	-	+	+	+	+	+	+	+
A H. total(us) (Dots)	31.778 (800)		26.666 (840)	21.333 (1056)	18.631 (1048)	16.660 (1312)	14.561 (1312)	15.63 (1688)	12.504 (1688)	10.971 (1728)
B H. sync(us) (Dots)	3.813 (96)		2.032 (64)	1.616 (80)	1.138 (64)	1.219 (96)	1.016 (96)	1.037 (112)	1.067 (144)	1.061 (160)
C H. back porch(us) (Dots)	1.907 (48)		3.809 (120)	3.232 (160)	2.702 (152)	2.235 (176)	2.201 (208)	2.296 (248)	1.837 (248)	1.422 (224)
D H. active(us) (Dots)	25.422 (640)		20.317 (640)	16.162 (800)	14.222 (800)	13.003 (1024)	10.836 (1024)	11.852 (1280)	9.481 (1280)	8.127 (1280)
E H. front porch(us) (Dots)	0.636 (16)		0.508 (16)	0.323 (16)	0.569 (32)	0.203 (16)	0.508 (48)	0.444 (48)	0.119 (16)	0.406 (64)
Vertical Freq. (Hz)	70.089	59.940	75.000	75.000	85.000	75	85.000	60.200	75.025	85.024
Sync. Polarity	+	-	-	+	+	+	+	+	+	+
O V. total(ms) (Lines)	14.268 (449)	16.684 (525)	13.333 (500)	13.333 (625)	11.756 (631)	13.853 (666)	11.765 (808)	16.661 (1066)	13.329 (1066)	11.761 (1072)
P V. sync(ms) (Lines)	0.064 (2)	0.064 (2)	0.080 (3)	0.064 (3)	0.056 (3)	0.125 (6)	0.044 (3)	0.047 (3)	0.038 (3)	0.033 (3)
Q V. back porch(ms) (Lines)	1.112 (35)	1.048 (33)	0.426 (16)	0.448 (21)	0.503 (27)	0.478 (23)	0.524 (36)	0.594 (38)	0.475 (38)	0.483 (44)
R V. active(ms) (Lines)	12.711 (400)	15.254 (480)	12.800 (480)	12.800 (600)	11.179 (600)	12.480 (600)	11.183 (768)	16.005 (1024)	12.804 (1024)	11.235 (1024)
S V. front porch(ms) (Lines)	0.381 (12)	0.381 (10)	0.027 (1)	0.021 (1)	0.019 (1)	0.770 (37)	0.015 (1)	0.016 (1)	0.013 (1)	0.011 (1)
Video clock Freq. (MHz) (ns)	25.175 (39.72)		31.501 (31.7)	49.500 (20.2)	56.250 (17.78)	56.250 (17.78)	94.500 (10.58)	108.00 (9.26)	135 (7.4)	157.5 (6.3)

**Timing chart : G90f**

Mode No.	11	12	13
Mode Name	VESA 1600x 1200	MAC 832 x 624	MAC 1152X 870
Horizontal Freq. (KHz)	93.75	49.717	68.681
Sync. Polarity	+	-	-
A H. total(us) (Dots)	10.667 (2160)	20.115 (1152)	14.56 (1456)
B H. sync(us) (Dots)	0.948 (192)	1.118 (64)	1.280 (128)
C H. back porch(us) (Dots)	1.501 (304)	3.911 (224)	1.44 (144)
D H. active(us) (Dots)	7.901 (1600)	14.528 (832)	11.52 (1152)
E H. front porch(us) (Dots)	0.316 (64)	0.558 (32)	0.32 (32)
Vertical Freq. (Hz)	75	74.530	75
Sync. Polarity	+	-	-
O V. total(ms) (Lines)	13.333 (1250)	13.417 (667)	13.322 (915)
P V. sync(ms) (Lines)	0.032 (3)	0.060 (3)	0.044 (3)
Q V. back porch(ms) (Lines)	0.491 (46)	0.784 (39)	0.568 (39)
R V. active(ms) (Lines)	12.8 (1200)	12.552 (624)	12.667 (870)
S V. front porch(ms) (Lines)	0.011 (1)	0.021 (1)	0.044 (3)
Video clock Freq. (MHz) (ns)	202.5 (4.9)	57.270 (17.5)	100 (10)

Confidential - Do Not Copy

## Appendix B :

Time: 09:47:03

Date: Tue Jul 11, 2000

**VIEWSONIC CORPORATION**  
**EDID Version # 1, Revision # 3**  
**DDC Test For: VSC G90f**

128 bytes of EDID code.

	0	1	2	3	4	5	6	7	8	9
0	00	FF	FF	FF	FF	FF	FF	00	5A	63
10	01	05	01	01	01	01	01	0A	01	63
20	1D	25	1B	B0	EB	00	B8	A0	57	49
30	9B	26	10	48	4C	FF	FF	80	81	8F
40	A9	4F	A9	40	81	80	81	99	61	59
50	45	59	31	59	1A	4F	40	30	62	B0
60	32	40	40	C0	13	00	65	0C	11	00
70	00	1E	00	00	00	FF	00	33	30	57
80	30	30	30	31	30	30	30	30	31	0A
90	00	00	00	FD	00	32	B4	1E	61	14
100	00	0A	20	20	20	20	20	20	00	00
110	00	FC	00	47	39	30	66	0A	20	20
120	20	20	20	20	20	20	00	8E		

- (08-09) ID Manufacturer Name \_\_\_\_\_ = VSC  
(10-11) Product ID Code \_\_\_\_\_ = 0105  
(12-15) Last 5 Digits of Serial Number \_\_\_\_\_ = Not Used  
(16) Week of Manufacture \_\_\_\_\_ = 01  
(17) Year of Manufacture \_\_\_\_\_ = 2000  
(10-17) Complete Serial Number \_\_\_\_\_ = See Descriptor Block  
(18) EDID Version Number \_\_\_\_\_ = 1  
(19) EDID Revision Number \_\_\_\_\_ = 3  
(20) VIDEO INPUT DEFINITION:  
Analog Signal  
0.700, 0.300 (1.000 Vp-p)  
Serration of the Vsync, Composite Sync, Separate Syncs,  
Blank-to-Black Setup  
(21) Maximum Horizontal Image Size \_\_\_\_\_ = 370mm  
(22) Maximum Vertical Image Size \_\_\_\_\_ = 270mm  
(23) Display Gamma \_\_\_\_\_ = 2.76  
(24) DPMS and Supported Feature(s):

Stand-By, Suspend, Active Off, Preferred Timing Mode, GTF supported  
Display Type = R/G/B Color

(25-34) CHROMA INFO:

Red X - 0.625 Green X - 0.285 Blue X - 0.150 White X - 0.283  
Red Y - 0.340 Green Y - 0.605 Blue Y - 0.065 White Y - 0.297

(35) ESTABLISHED TIMING I:

720 X 400 @ 70Hz (IBM,VGA)  
720 X 400 @ 88Hz (IBM,XGA2)  
640 X 480 @ 60Hz (IBM,VGA)  
640 X 480 @ 67Hz (Apple, Mac II)  
640 X 480 @ 72Hz (VESA)  
640 X 480 @ 75Hz (VESA)  
800 X 600 @ 56Hz (VESA)  
800 X 600 @ 60Hz (VESA)

(36) ESTABLISHED TIMING II:

800 X 600 @ 72Hz (VESA)  
800 X 600 @ 75Hz (VESA)  
832 X 624 @ 75Hz (Apple, Mac II)  
1024 X 768 @ 87Hz(Interlaced 8514a, IBM)  
1024 X 768 @ 60Hz (VESA)  
1024 X 768 @ 70Hz (VESA)  
1024 X 768 @ 75Hz (VESA)  
1280 X 1024 @ 75Hz (VESA)

(37) Manufacturer's Reserved Timing:

1152 X 870 @ 75Hz (Apple,Mac II)

(38-53) Standard Timing Identification:

1280 X 1024 @75Hz  
1600 X 1200 @75Hz  
1600 X 1200 @60Hz  
1280 X 1024 @60Hz  
1280 X 1024 @85Hz  
1024 X 768 @85Hz  
800 X 600 @85Hz  
640 X 480 @85Hz

---

(54-71) Detailed Timing / Descriptor Block 1:

1600x1200 Pixel Clock: 202.50 MHz

---

Horizontal Image Size: 357 mm	Vertical Image Size: 268 mm
Refreshed Mode: Non-Interlaced	Normal Display - No Stereo

Horizontal:

Active Time	: 1600 pixels	Blanking Time: 560 pixels
Sync Offset	: 64 pixels	Sync Pulse Width: 192 pixels
Border	: 0 pixels	Frequency: 93.75 KHz

Vertical:

Active Time	: 1200 lines	Blanking Time:	50 lines
Sync Offset	: 1 lines	Sync Pulse Width:	3 lines
Border	: 0 lines	Frequency:	75.00 Hz

Digital Separate, Horizontal Polarity (+) Vertical Polarity (+)

---

(72-89) Detailed Timing / Descriptor Block 2:

Monitor Serial Number:  
30W000100001

---

(90-107) Detailed Timing / Descriptor Block 3:

Monitor Range Limits:  
Min Vertical Freq - 50 Hz  
Max Vertical Freq - 180 Hz  
Min Horiz. Freq - 30 KHz  
Max Horiz. Freq - 97 KHz  
Pixel Clock - 200 MHz  
GTF - Not Used

---

(108-125) Detailed Timing / Descriptor Block 4:

Monitor Name:  
G90f

(126) No Extension EDID Block(s)

(127) CheckSum OK

## 2. OSD ( on screen display ) Function Control

- Main Menu 1
  - Contrast / Brightness
  - H. size / Position
  - V. size / Position
  - Pincushion / Balance
  - Trapezoid / Parallel
  - Top /Bottom Hook
  - H / V Focus
  - Tilt
- Main Menu 2
  - Degauss
  - H/V Moire
  - Viewmatch color
  - Video Level
  - Language
  - OSD Position
  - Viewmeter
  - Memory Recall

## Front Control Panel for G90f

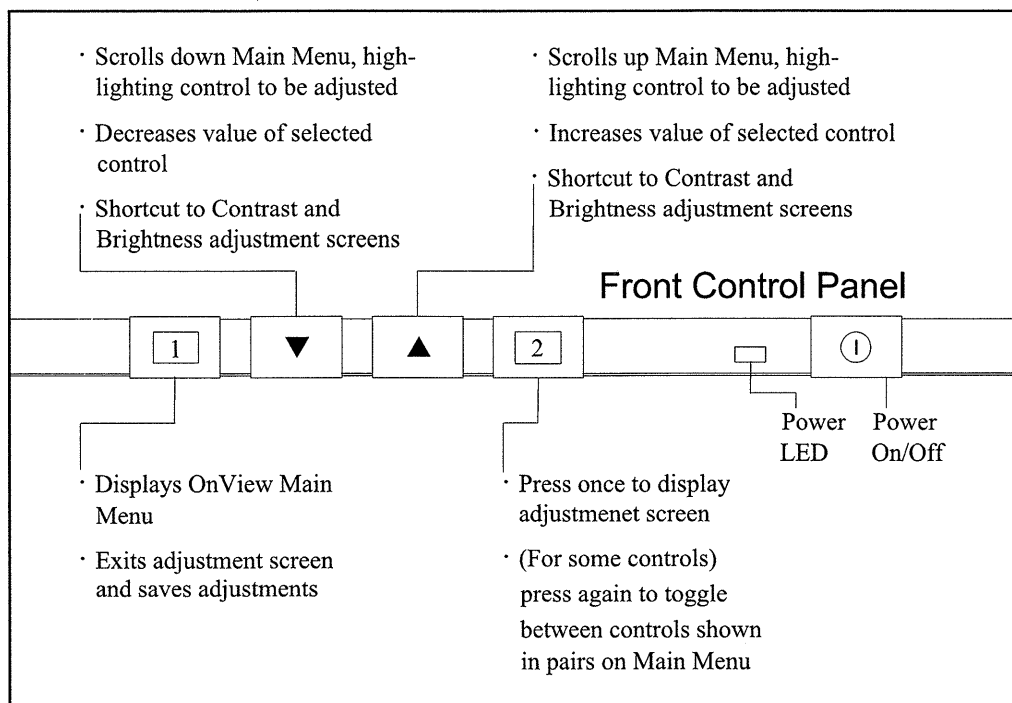

### Using the Front Control Panel to access OnView screens

- To turn the monitor on, press the Power button (shown above).
- To display to OnView Main Menu, press button [ 1 ] .
- To select a user control, press the ▼ or ▲ button repeatedly until the control is **High lighted**.
- To display an OnView adjustment screen, press button [ 2 ] .  
Some controls are grouped in pairs on the Main Menu (see page 12). Press button [ 2 ] to toggle between them.
- To adjust the selected user control, press the ▼ or ▲ button.  
*Exception:* For user controls that do not require adjustments, press button [ 2 ] again to activate. (examples: Degauss, Memory Recall).
- To save your adjustments and exit all screens, press button [ 1 ] *twice*.  
The screen will clear automatically about 30 seconds after the last control button you press. To return to the Main Menu, repeat step 2.



**Main Menu, Part1**

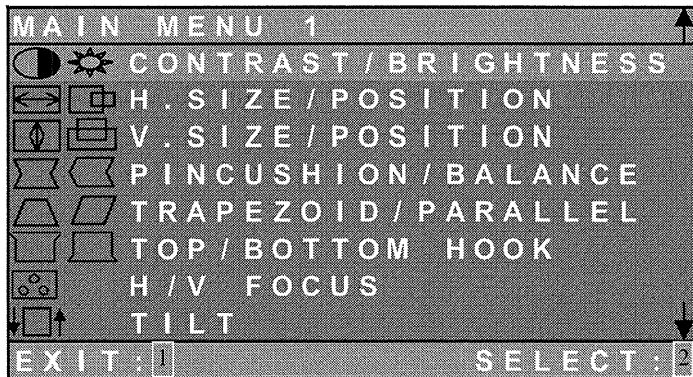

**☀ CONTRAST/BRIGHTNESS:**

With CONTRAST/BRIGHTNESS highlighted on the menu, press button [2] again to toggle between BRIGHTNESS and CONTRAST.

**● CONTRAST**

Adjusts the foreground white level of the screen image. [▲] increases the contrast of the image. [▼] decreases the contrast of the image.

**Shortcut:**

You can also display the CONTRAST control screen by pressing either [▲] or [▼] before displaying the main menu. From the CONTRAST control screen, button [2] goes to the BRIGHTNESS control screen.



Button [2] toggles to the BRIGHTNESS control screen.

**☀ BRIGHTNESS**

Adjusts the background brightness of the screen image. [▲] increases the brightness of the screen image. Decreases the brightness of the screen image.



Button [2] toggles to the CONTRAST control screen.

 **H. SIZE/POSITION:**

With H.SIZE/POSITION highlighted on the menu, press button [2] again to toggle between HORIZONTAL SIZE and HORIZONTAL POSITION.

 **HORIZONTAL SIZE**

Adjusts the width of the screen image. [▲] increases width. [▼] decreases width.

 **HORIZONTAL POSITION**

Moves the screen image left or right. [▲] moves the screen image right. [▼] moves the screen image left.

 **V. SIZE/POSITION:**

With V.SIZE/POSITION highlighted on the menu, press button [2] again to toggle between VERTICAL SIZE and VERTICAL POSITION.

 **VERTICAL SIZE**

Adjusts the height of the screen image. [▲] increases the screen height. [▼] decreases the screen height.

 **VERTICAL POSITION**

Moves the screen image up and down. [▲] moves the screen up. [▼] moves the screen down.

 **PINCUSHION / BALANCE**

With PINCUSHION/BALANCE high lighted on the menu, Press button [2] again to toggle between pincushion and Pin-balance.

 **PINCUSHION**

Straightens the vertical sides of the screen image. [▲] curves the vertical sides outward. [▼] curves the vertical sides inward.

 **PIN-BALANCE**

Straightens the vertical sides of the screen image. [▲] curves the vertical sides to left. [▼] curves the vertical sides to right.

 **TRAPEZOID/PARALLEL:**

With TRAPEZOID/PARALLEL highlighted on the menu, press button [2] again to toggle between TRAPEZOID and PARALLELOGRAM.

 **TRAPEZOID**

Makes a vertical side of the screen image parallel. [▲] widens the top and narrows the bottom. [▼] narrows the top and widens the bottom.

 **PARALLEL (PARALLELOGRAM)**

Slants vertical edges of the screen to the left or right. [▼] slants vertical edges to left, [▲] slants vertical edges to right.

 **TOP /BOTTOM HOOK**

With TOP HOOK highlighted on the menu, Press button [2] again to toggle between top hook and bottom hook

 **TOP HOOK**

Straightens the top corners of the screen image. [▼] or [▲] to adjust.

 **BOTTOM HOOK**

Straightens the bottom corners of the screen image. [▼] or [▲] to adjust.

**H. / V. FOCUS**

**H. FOCUS** fine tunes the horizontal line focus only. Press [▼] or [▲] to adjust

**V. FOCUS** fine tunes the vertical line focus only. Press [▼] or [▲] to adjust

**TILT**

Rotates the entire screen image. [▲] rotates the screen clockwise, [▼] rotates the screen counter-clockwise.

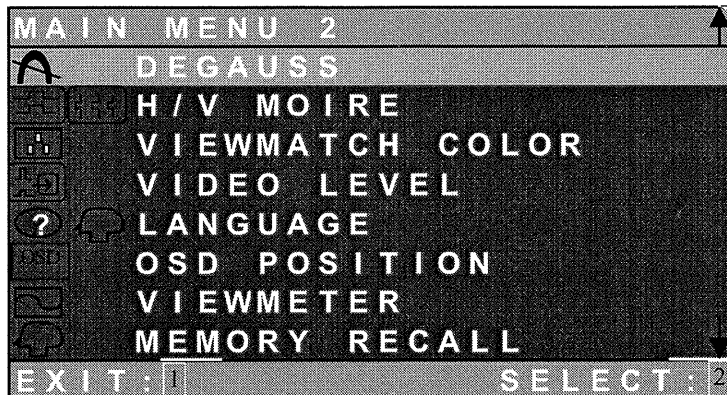
**Main Menu, Part 2****DEGAUSS**

Removes the build-up of magnetic fields that can affect color purity and convergence. Press the button [2] to degauss.

**H/V MOIRE**

With H/V moire highlighted on the menu, Press button [2] again to toggle between H-moire and V-moire.

**H MOIRE**

The control adjusts for horizontal lines caused by interference between the CRT and focus gun. [▼] decrease the amount of adjustment, [▲] increases the amount of adjustment.

**V MOIRE**

The control adjust for vertical lines caused by interference between the CRT and focus gun. [▼] decrease the amount of adjustment, [▲] increases the amount of adjustment.

**VIEWMATCH COLOR**

Provides three color control options including two preset color temperatures. Press button [2] to select a color temperature or USER.

**9300K**

Is the factory setting that is most popular for this monitor. 9300K adds blue to the screen image for a cooler white used in most office settings with fluorescent lighting.

**6500K**

Adds red to screen image for warmer white and richer, more vibrant red.

**5500K**

Adds green to screen image for a darker color.

**USER**

Control adjusts reds, greens, and blues on the screen image to meet your personal preference. With the USER control screen display, press button [2] to select R, G or B. Then, press [▲] to increase and [▼] to decrease the color intensity.

**VIDEO LEVEL**

Allows you to change the video input signal level to match the signal coming from your computer. Press [▼] or [▲] to select 0.7V or 1.0V.

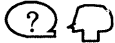
**LANGUAGE**

Of the MAIN MENU and the control screens. Use [▲] and [▼] to select English, French, German, Italian, or Spanish.

**OSD POSITION**

With OSD position highlighted on the menu, Press button [2] again to toggle between H-OSD position and V-OSD position.

**VIEWMETER**

Screen by ViewSonic displays the current horizontal and vertical synchronization signal (refresh rate) coming from your computer. To adjust these values, see the graphic's card user's guide for your computer.

**MEMORY RECALL**

Returns adjustments back to factory settings only if the monitor is operating in a factory preset mode.

*Exception:*

This control does not affect changes made with the **USER** color control.

**Model name : ViewSonic G90f**

## **OSD diagnostic message format**

**1. When power is turn on momentarily but no signal input then show :**

**PLEASE  
CHECH SIGNAL**

**2. If monitor into DPMS mode will show :**

**DPMS  
STANDBY MODE**

**DPMS  
SUSPEND MODE**

**DPMS  
OFF MODE**

**3. If input H-sync or V-sync over range well show :**

**FREQUENCY  
OVER RANGE**

### 3. Circuit diagram

#### 1. G90f circuit diagram

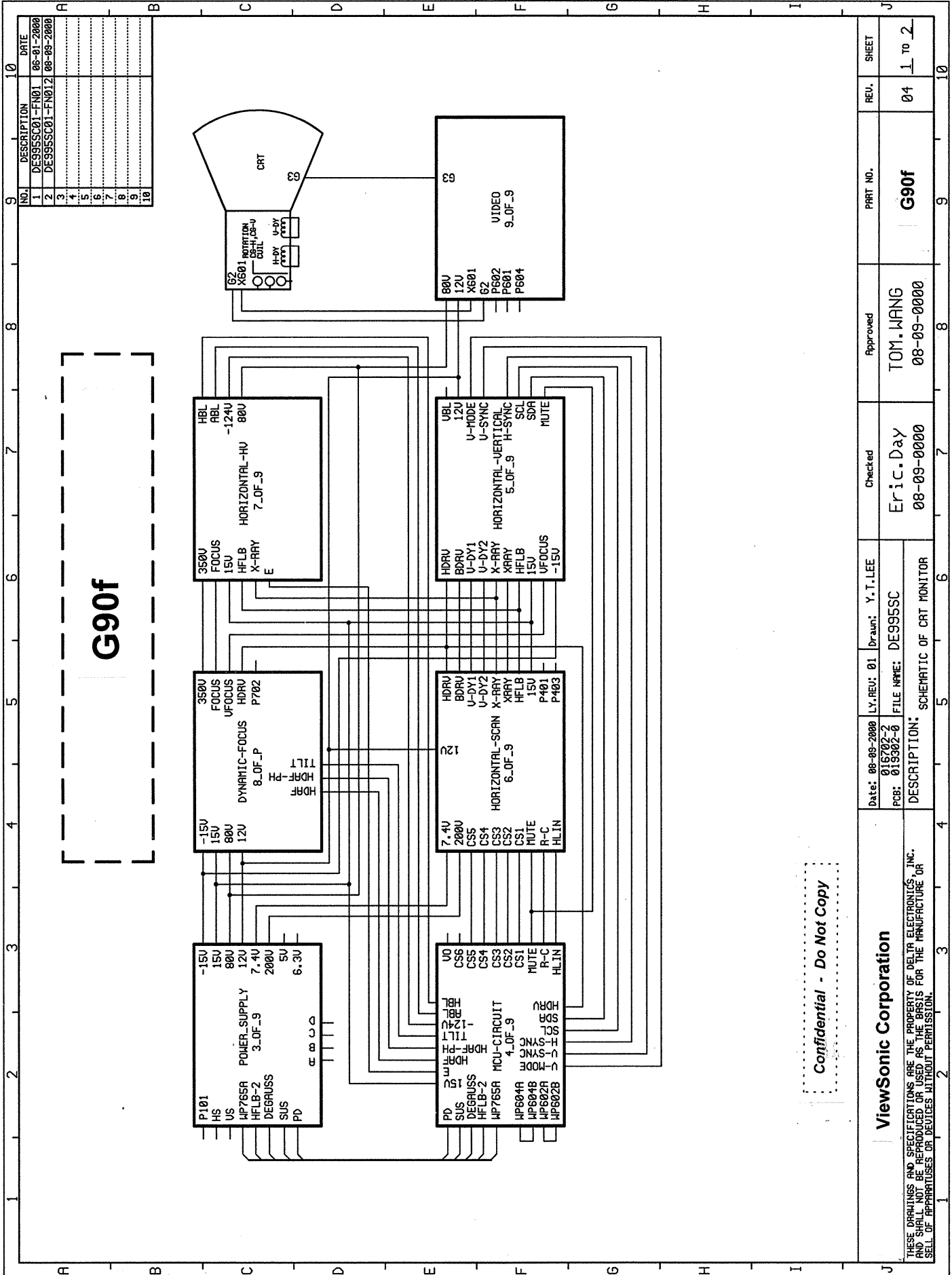

G90f

Confidential - Do Not Copy

NO.	DESCRIPTION	DATE
1	DE95SC01-FN01	06-01-2000
2	DE95SC01-FN012	06-09-2000
3		
4		
5		
6		
7		
8		
9		
10		

NO.	DESCRIPTION	DATE	REV.	SHEET
1	DE95SC01-FN01	06-01-2000	04	1 TO 2
2	DE95SC01-FN012	06-09-2000		
3				
4				
5				
6				
7				
8				
9				
10				

Date: 06-09-2000	LY.REV: 01	Drawn: Y. T. LEE	Checked: Eric. Day	Approved: TOM. WANG
PCB: 015302-0	FILE NAME: DE95SC			
DESCRIPTION: SCHEMATIC OF CRT MONITOR				

**ViewSonic Corporation**

THESE DRAWINGS AND SPECIFICATIONS ARE THE PROPERTY OF DELTA ELECTRONICS, INC. AND SHALL NOT BE REPRODUCED OR USED AS THE BASIS FOR THE MANUFACTURE OR SELL OF APPARATUS OR DEVICES WITHOUT PERMISSION.

Frame Name: FR9-1R00.SCH

# DE-995 SC 01 COLOR MONITOR BLOCK DIAGRAM

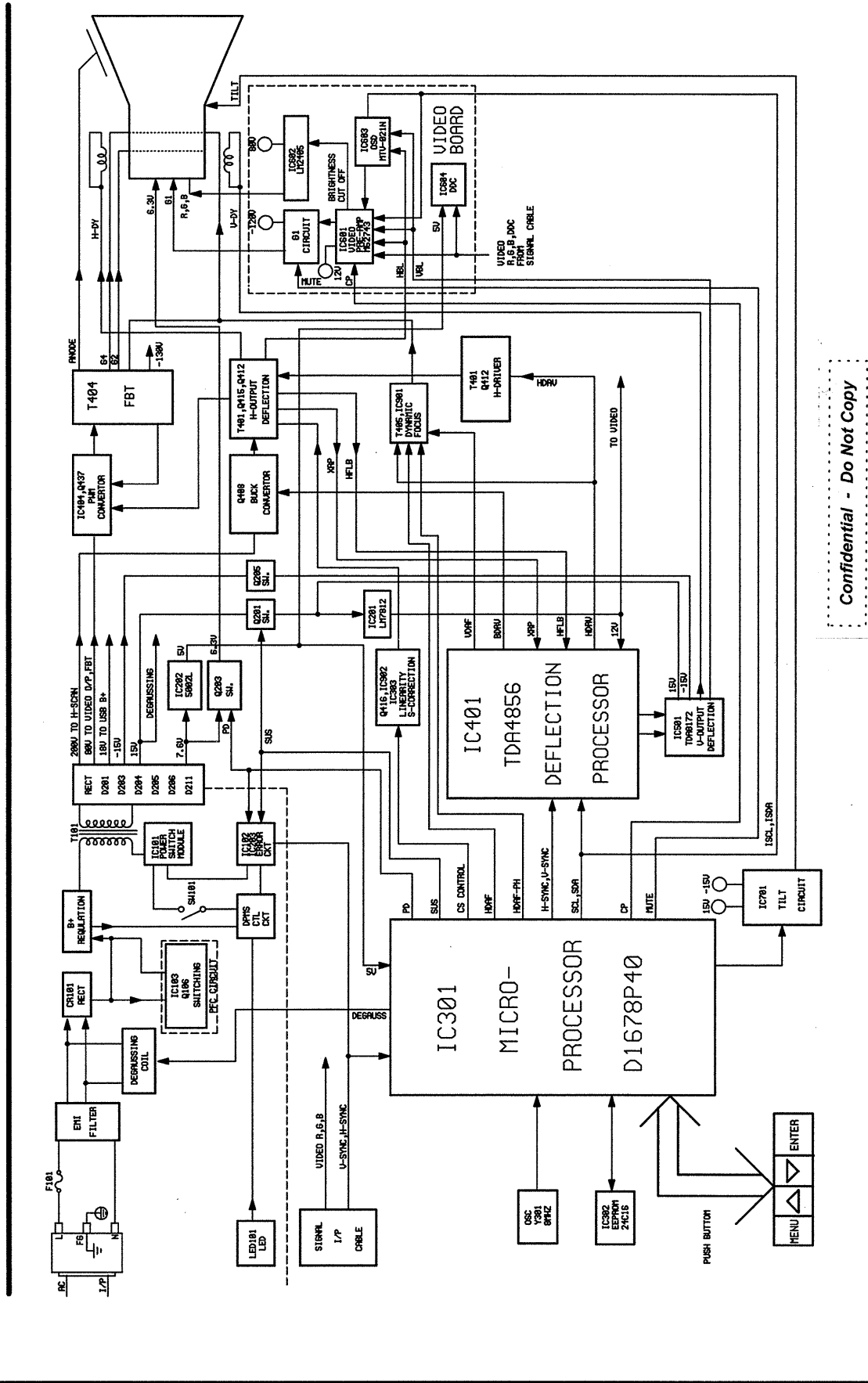

Confidential - Do Not Copy

<b>ViewSonic Corporation</b>	Date: 08-09-2000 LY.REV: 01 PCB: 019302-0	Drawn: Y.T.LEE Checked: Eric.Day Approved: TOM.WANG	PART NO. <b>G90f</b> REV. 04 SHEET 2 to 3
THESE DRAWINGS AND SPECIFICATIONS ARE THE PROPERTY OF DELTA ELECTRONICS, INC. AND SHALL NOT BE REPRODUCED OR USED AS THE BASIS FOR THE MANUFACTURE OR SELL OF APPARATUS OR DEVICES WITHOUT PERMISSION.		DESCRIPTION: SCHEMATIC OF CRT MONITOR 08-09-2000 08-09-2000	



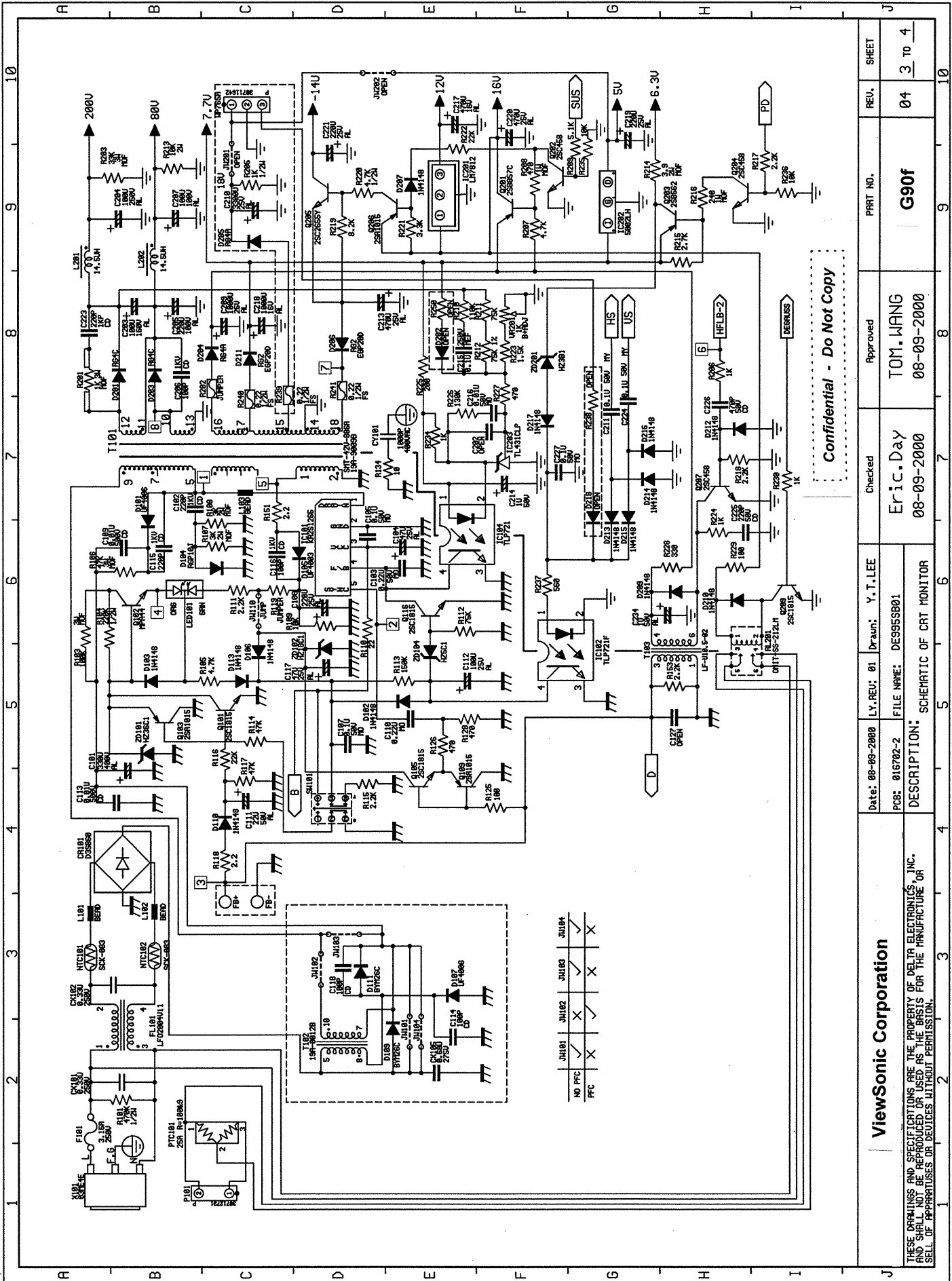

Confidential - Do Not Copy

ViewSonic Corporation		Date: 08-09-2000	LY.REU: 01	Drawn: Y. T. LEE	Checked	Approved	PART NO.	SHEET	
		PCB: 016702-2	FILE NAME: DESSESBD01	Eric. Day	TOM. WANG	G90f	04	3 to 4	
		DESCRIPTION: SCHEMATIC OF CRT MONITOR							10

THESE DRAWINGS AND SPECIFICATIONS ARE THE PROPERTY OF DELTA ELECTRONICS, INC. AND SHALL NOT BE REPRODUCED OR USED AS THE BASIS FOR THE MANUFACTURE OR SELL OF APPARATUS OR DEVICES WITHOUT PERMISSION.

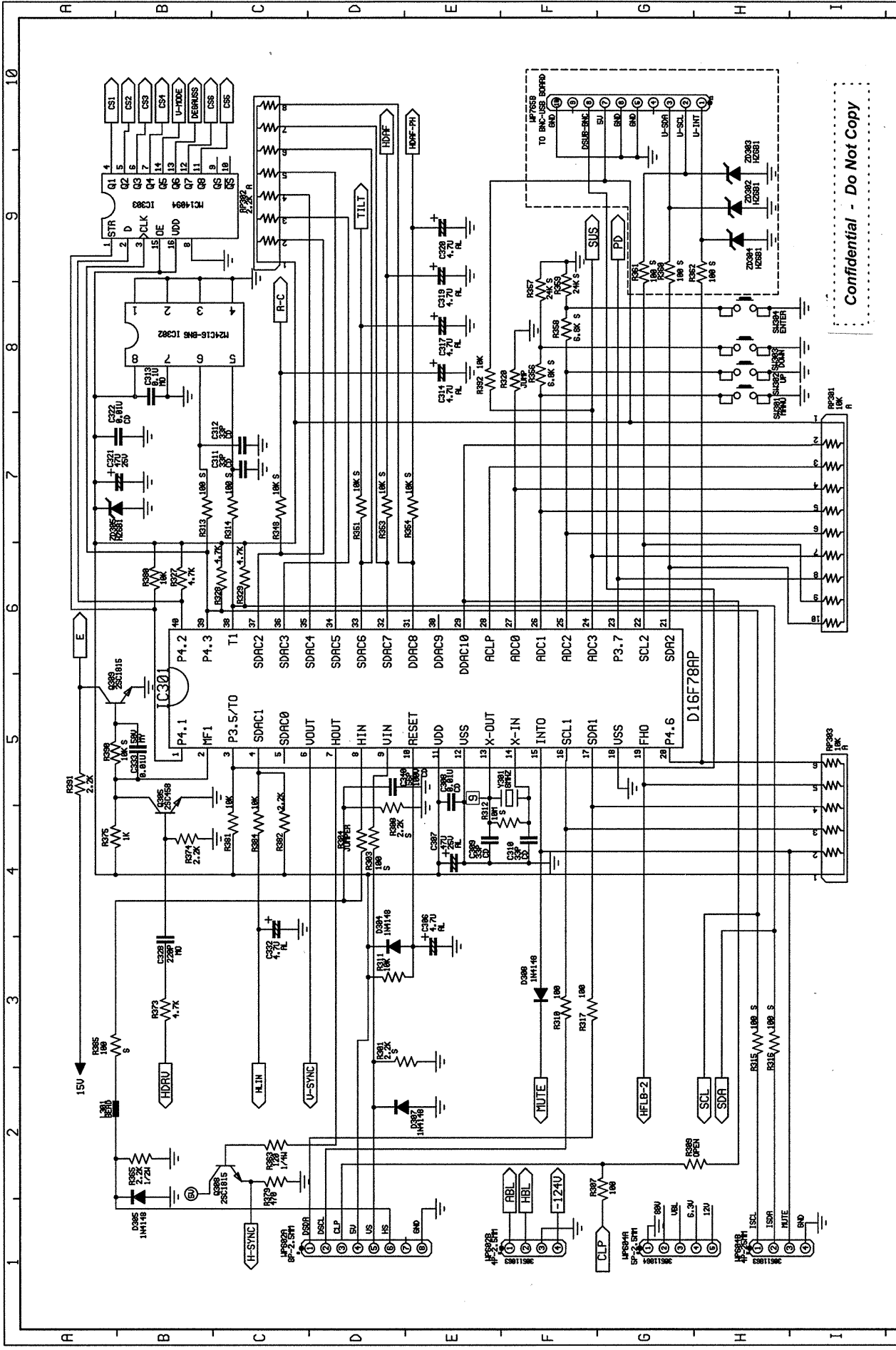

ViewSonic Corporation		Date: 08-09-2000	LY, REV: 01	Drawn: Y. T. LEE	Checked	Approved	PART NO.	REV.	SHEET
THESE DRAWINGS AND SPECIFICATIONS ARE THE PROPERTY OF DELTA ELECTRONICS, INC. AND SHALL NOT BE REPRODUCED OR USED AS THE BASIS FOR THE MANUFACTURE OR SALE OF APPARATUS OR DEVICES WITHOUT PERMISSION.		PCB: 016702-2		FILE NAME: DE955C	Eric Day		TOM WANG		4 to 5
		DESCRIPTION: SCHEMATIC OF CRT MONITOR		08-09-2000		08-09-2000		04	4 to 5
									10
									10

Frame Name: FRS-1R00.SCH

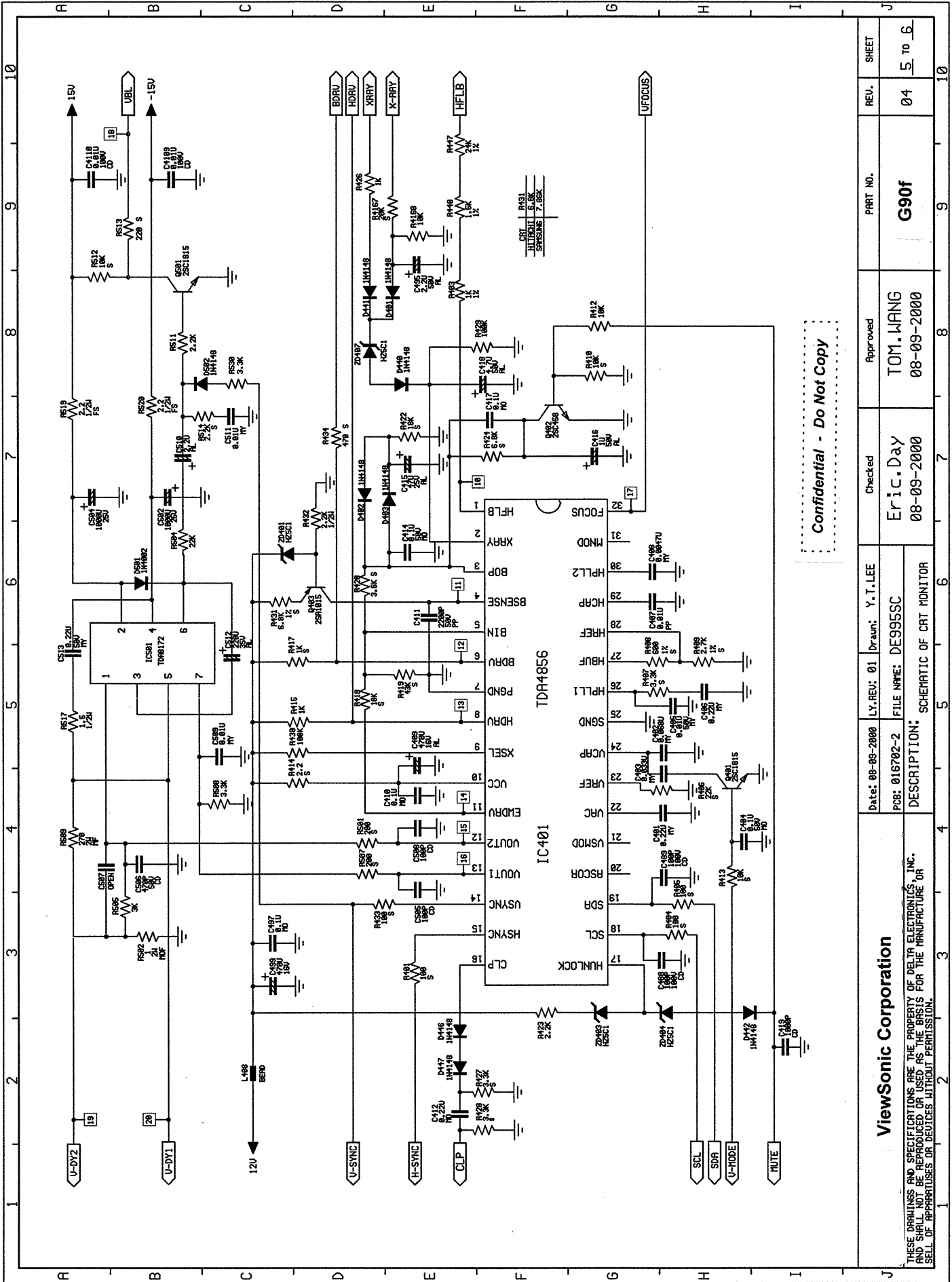

Confidential - Do Not Copy

<b>ViewSonic Corporation</b>		Date: 08-09-2000	LY.REV: 01	Drawn: Y. T. LEE	Checked	Approved	PART NO.	REV.	SHEET
THESE DRAWINGS AND SPECIFICATIONS ARE THE PROPERTY OF DELTA ELECTRONICS, INC. AND SHALL NOT BE REPRODUCED OR USED AS THE BASIS FOR THE MANUFACTURE OR SALE OF APPARATUS OR DEVICES WITHOUT PERMISSION.		P08: 016702-2		FILE NAME: DE955C		TOM. WANG		04	
DESCRIPTION: SCHEMATIC OF CRT MONITOR		08-09-2000		08-09-2000		G90f		5 to 6	
Frame Name: FFR-1R00. SCH									

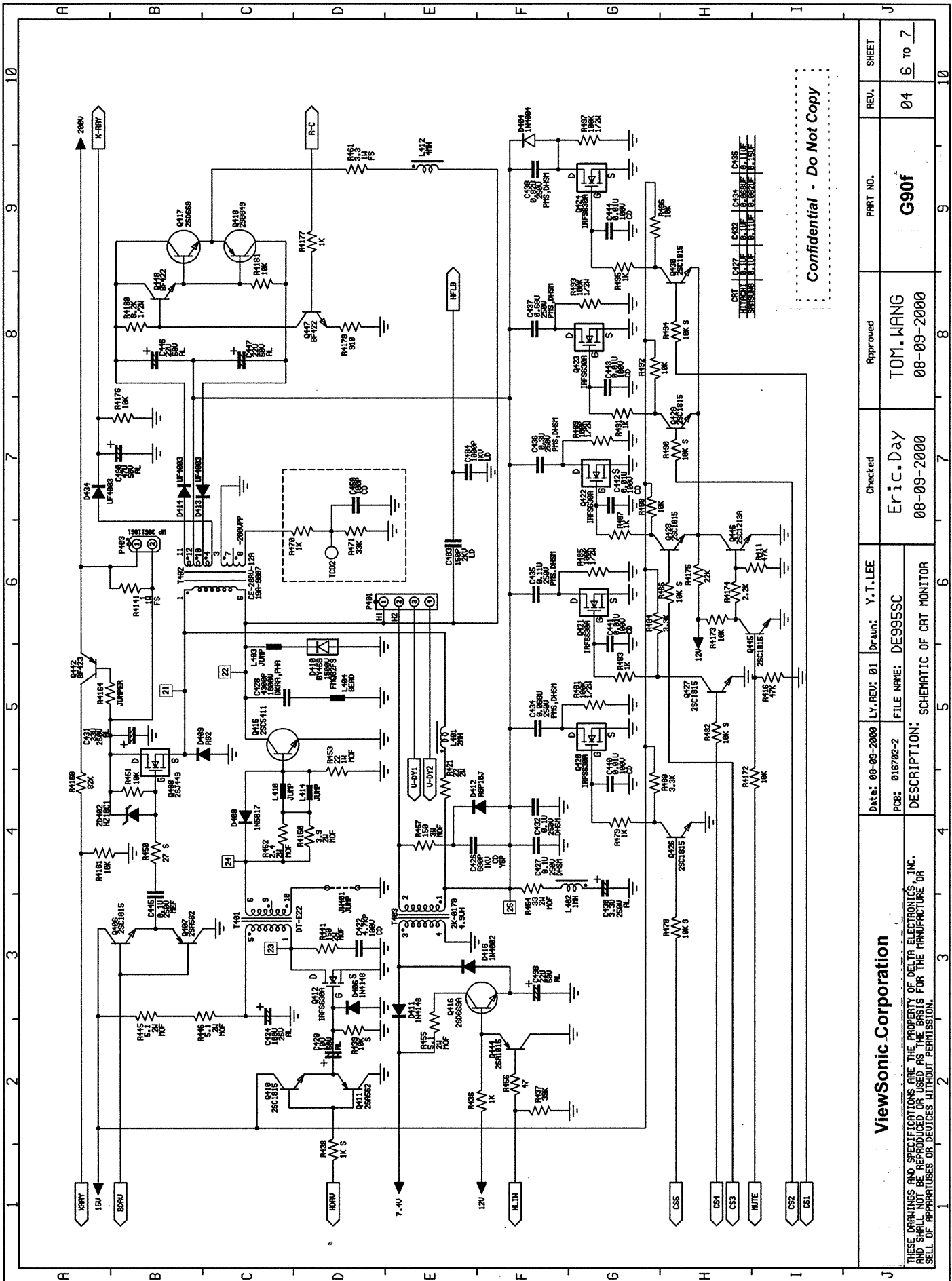

Confidential - Do Not Copy

ViewSonic Corporation		Date: 08-09-2008	LY.REV: 01	Drawn: Y. T. LEE	Checked	Approved	PART NO.	SHEET	
THESE DRAWINGS AND SPECIFICATIONS ARE THE PROPERTY OF DELTA ELECTRONICS, INC. AND SHALL NOT BE REPRODUCED OR USED AS THE BASIS FOR THE MANUFACTURE OR SELL OF APPARATUS OR DEVICES WITHOUT PERMISSION.		PCB: 015702-2	FILE NAME: DE955C	Eric. Day	TOM. WANG	G90f	04	6 to 7	
		DESCRIPTION: SCHEMATIC OF CRT MONITOR		08-09-2000	08-09-2000				
1	2	3	4	5	6	7	8	9	10

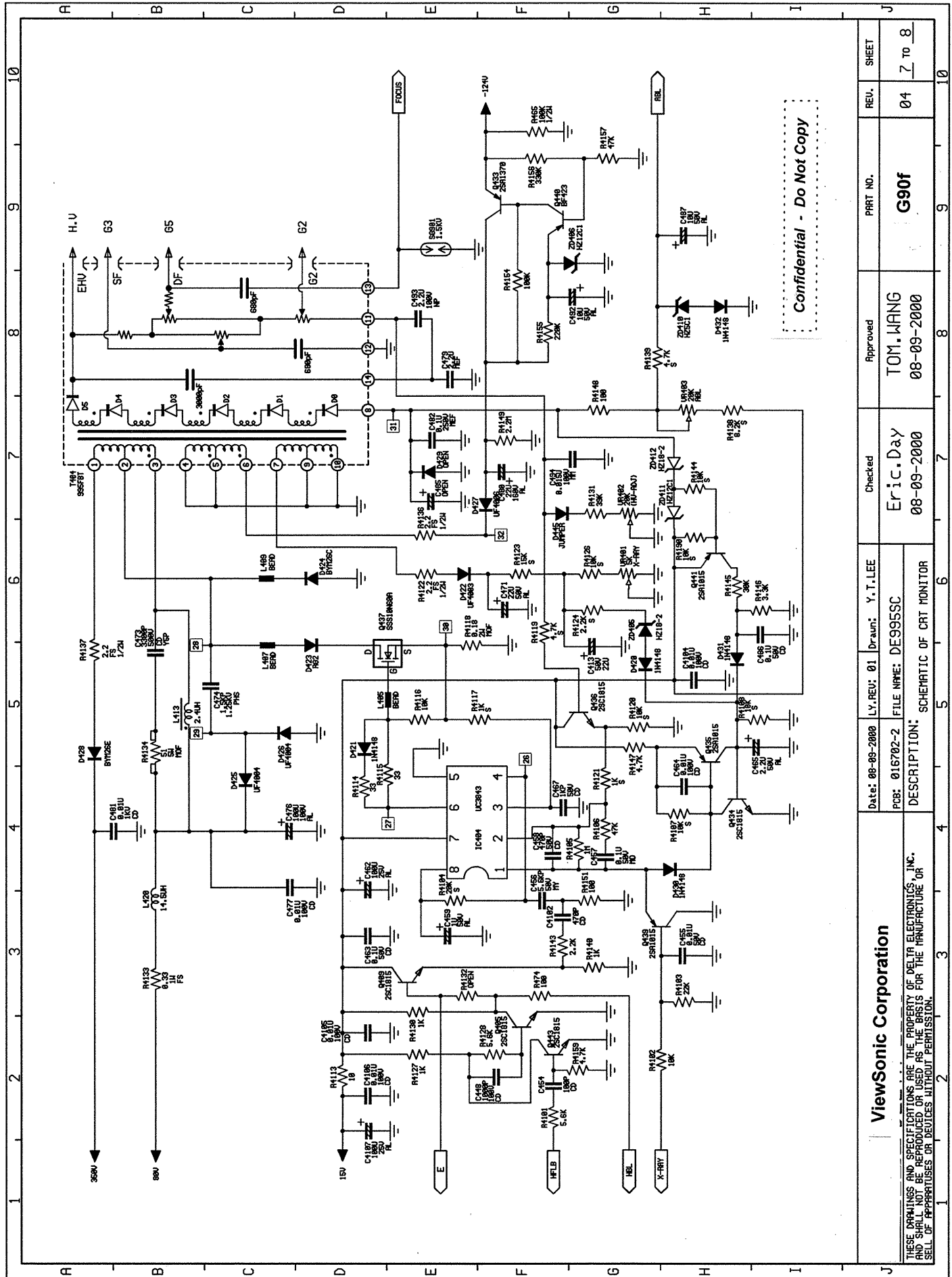

Confidential - Do Not Copy

ViewSonic Corporation		Date: 08-09-2000	LY REV: 01	Drawn: Y. T. LEE	Checked	Approved	PART NO.	SHEET
THESE DRAWINGS AND SPECIFICATIONS ARE THE PROPERTY OF DELTA ELECTRONICS, INC. AND SHALL NOT BE REPRODUCED OR USED AS THE BASIS FOR THE MANUFACTURE OR SELL OF APPARATUS OR DEVICES WITHOUT PERMISSION.		POB: 016702-2	FILE NAME: DE955C	Eric Day	TOM WANG	G90f	04	7 to 8
		DESCRIPTION: SCHEMATIC OF CRT MONITOR			08-09-2000	08-09-2000		10

Frame Name:FRS-1R00.SCH

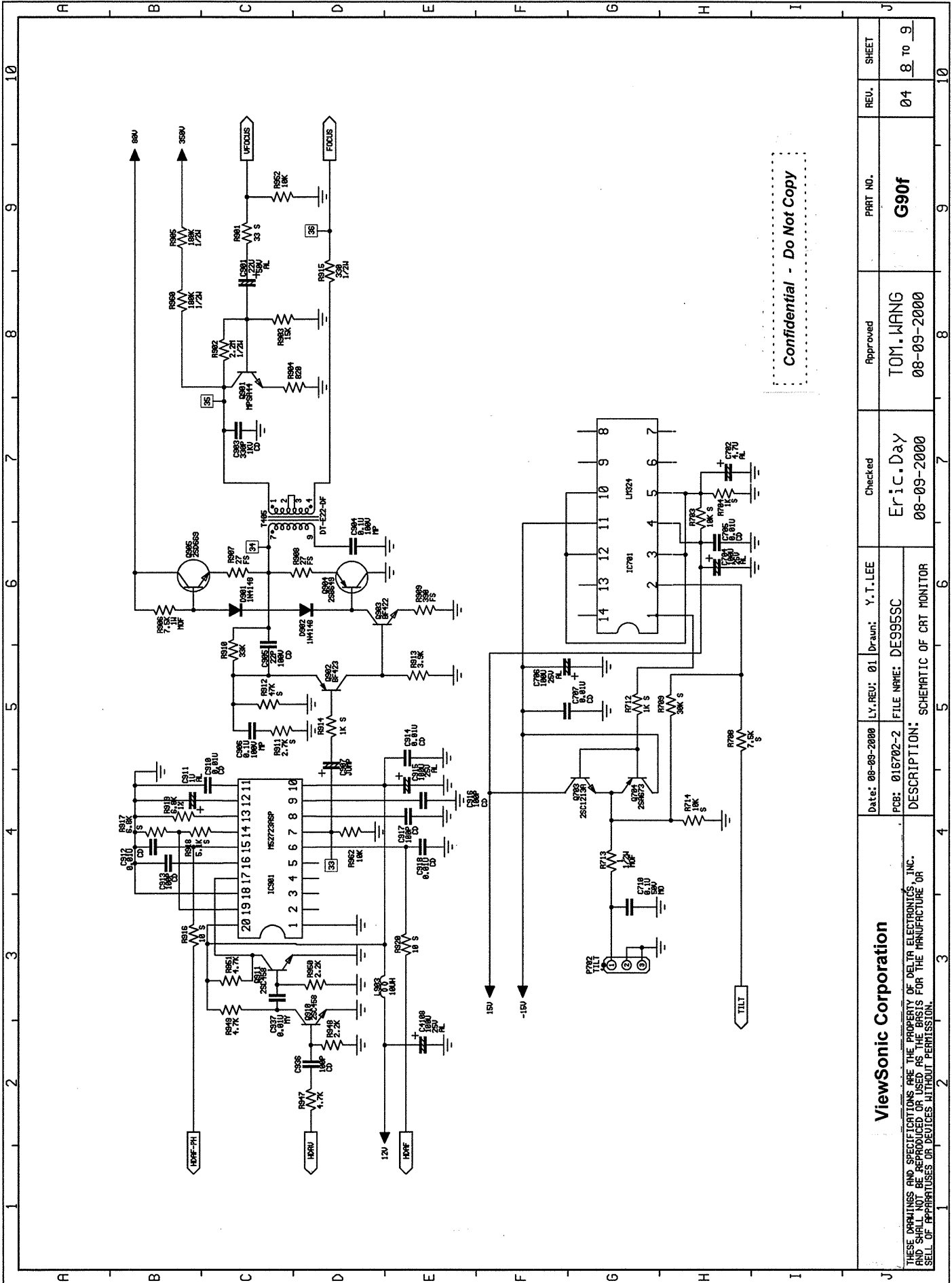

Confidential - Do Not Copy

<b>ViewSonic Corporation</b>	Date: 08-09-2000 LY.REU: 01 Drawn: Y. T. LEE	REV. SHEET 04 8 to 9
PCB: 016702-2 FILE NAME: DES955C	Checked Eric.Day	PART NO. <b>G90f</b>
DESCRIPTION: SCHEMATIC OF CRT MONITOR	Approved TOM.MANG 08-09-2000	REV. SHEET 04 8 to 9
THESE DRAWINGS AND SPECIFICATIONS ARE THE PROPERTY OF DELTA ELECTRONICS, INC. AND SHALL NOT BE REPRODUCED OR USED AS THE BASIS FOR THE MANUFACTURE OR SELL OF APPARATUS OR DEVICES WITHOUT PERMISSION.		
Frame Name: FFR-1R00.SCH		

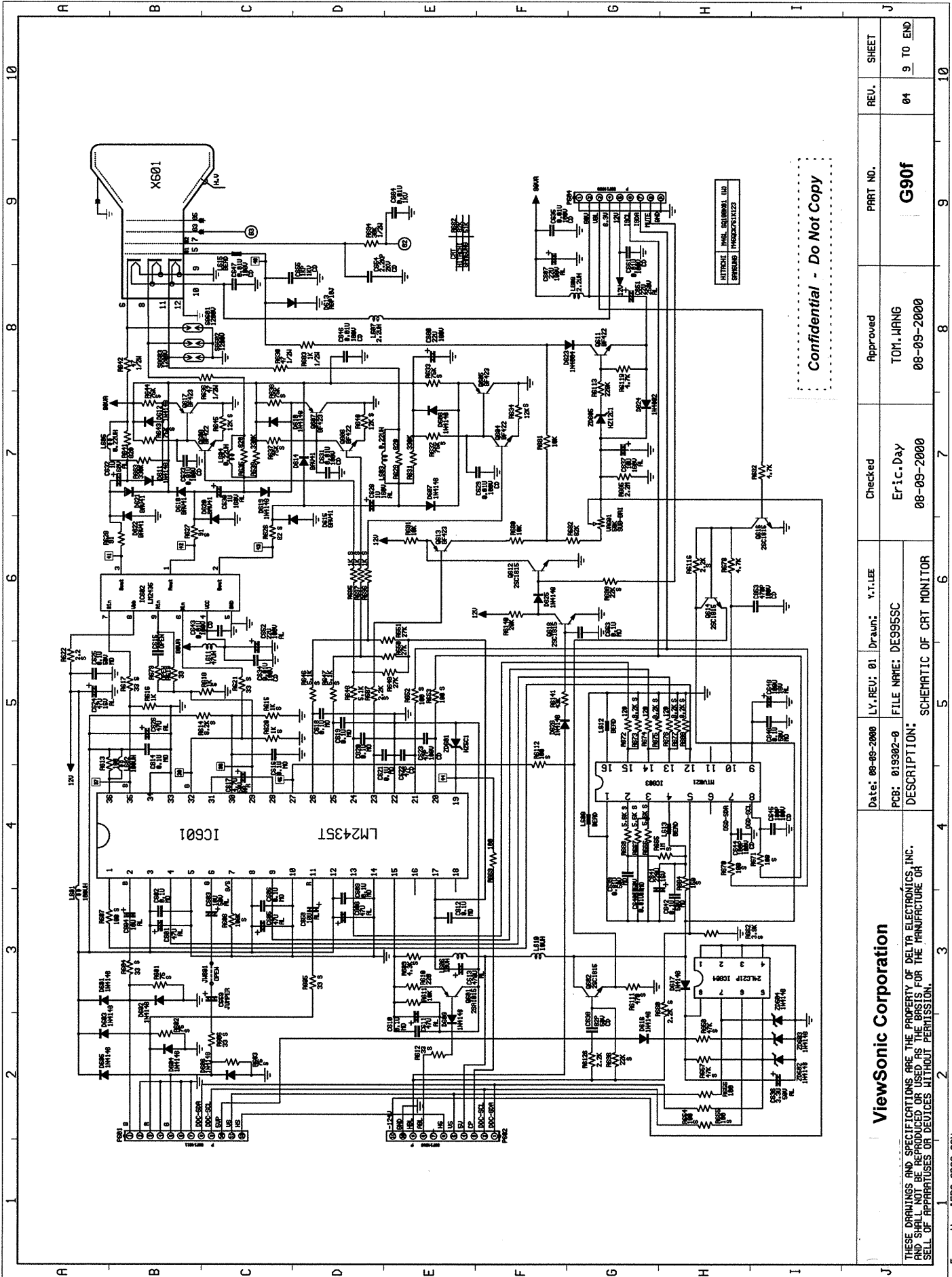

Confidential - Do Not Copy

	ViewSonic Corporation	Date: 08-09-2008	LY REV: 01	Drawn: Y.T.LEE	Checked	Approved	PART NO.	REV.	SHEET
		PCB: 019302-0		FILE NAME: DE9955C		Eric Day		TOM WANG	
		DESCRIPTION: SCHEMATIC OF CRT MONITOR		08-09-2000		08-09-2000		04	
						G90f		9 TO END	
								10	

THESE DRAWINGS AND SPECIFICATIONS ARE THE PROPERTY OF DELTA ELECTRONICS, INC. AND SHALL NOT BE REPRODUCED OR USED AS THE BASIS FOR THE MANUFACTURE OR SELL OF APPARATUS OR DEVICES WITHOUT PERMISSION.

Frame Name:FR0-2800.SCH

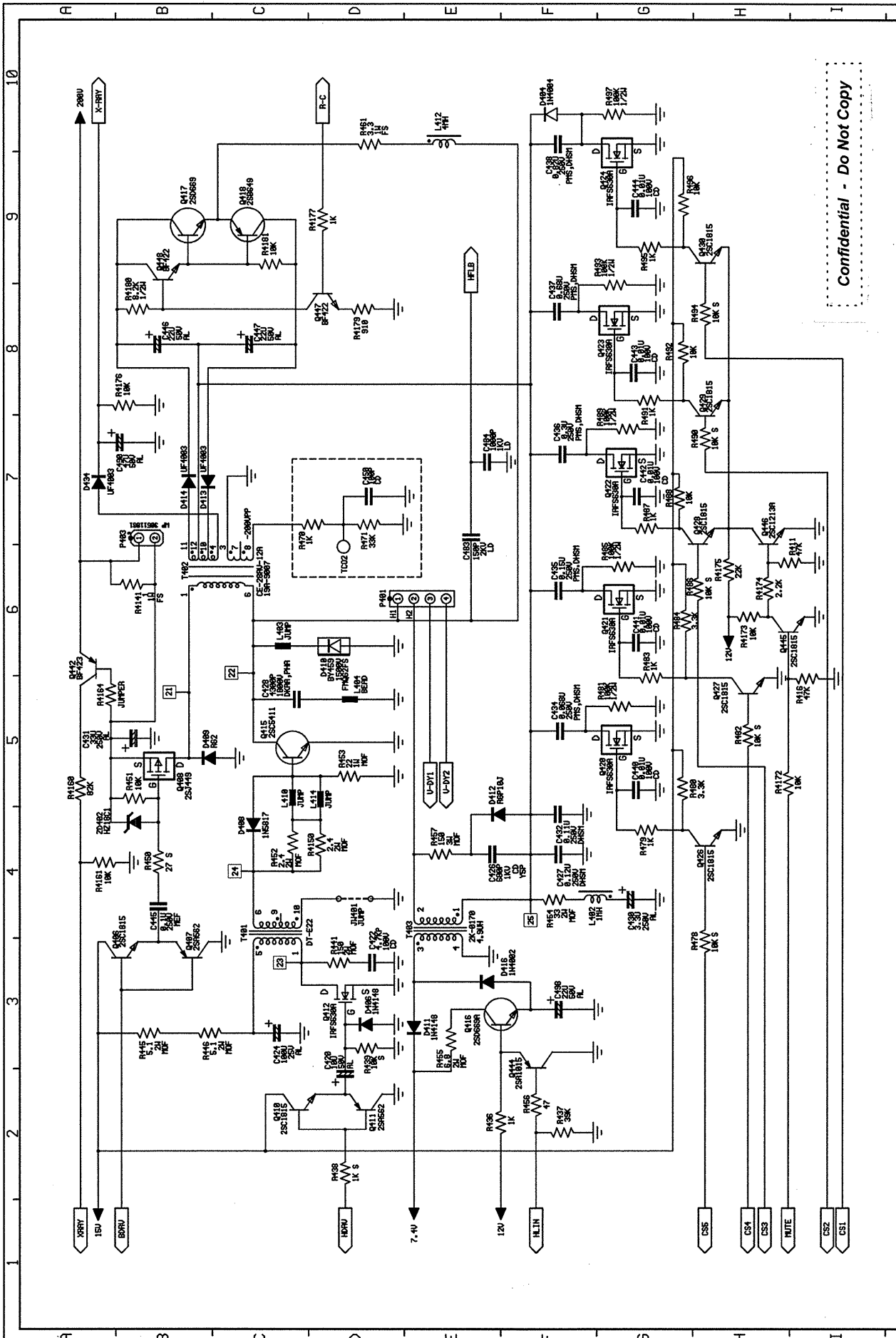

ViewSonic Corporation		Date: 08-09-2000	LY.REU: 00	Drawn: Y.T.LEE	Checked	Approved	PART NO.	SHEET
THESE DRAWINGS AND SPECIFICATIONS ARE THE PROPERTY OF DELTA ELECTRONICS, INC. AND SHALL NOT BE REPRODUCED OR USED AS THE BASIS FOR THE MANUFACTURE OR SELL OF APPARATUS OR DEVICES WITHOUT PERMISSION.		P08: 016792-2		FILE NAME: DES95S801	Eric.Day		G90f	00
		DESCRIPTION: SCHEMATIC OF CRT MONITOR		08-09-2000		08-09-2000		6
								7
								8
								9
								10



G90f/

TEST CONDITION :

AC SOURCE : 110V ; TIMING MODE ; 60KHZ ; PATTERN ; FULL WHITE

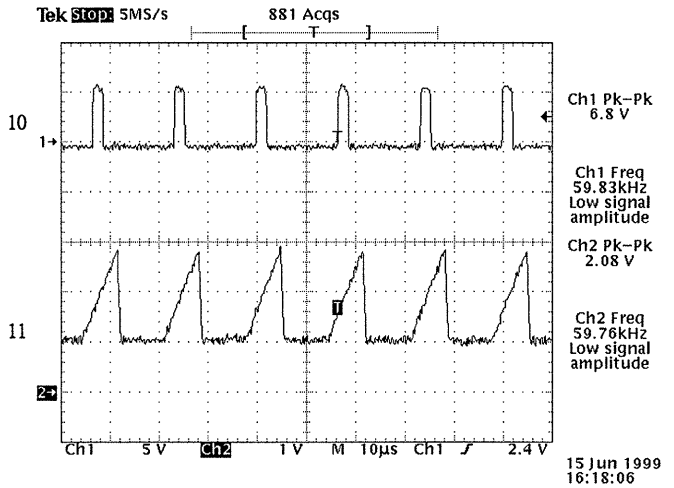
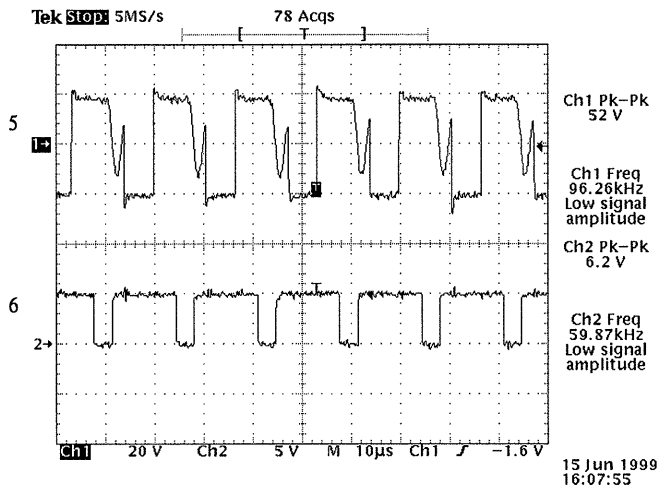
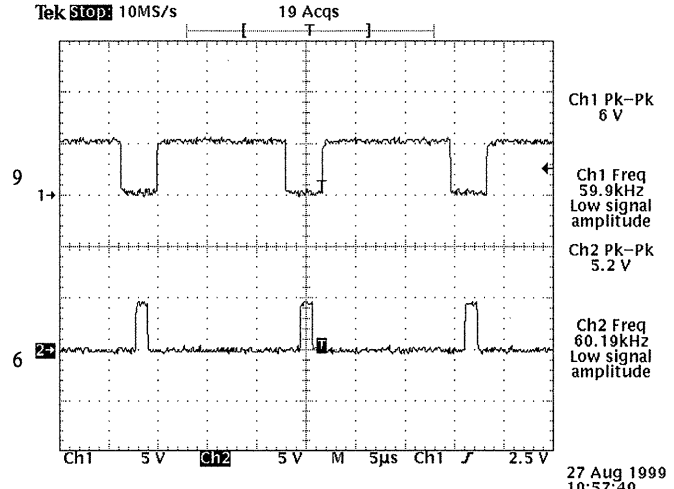
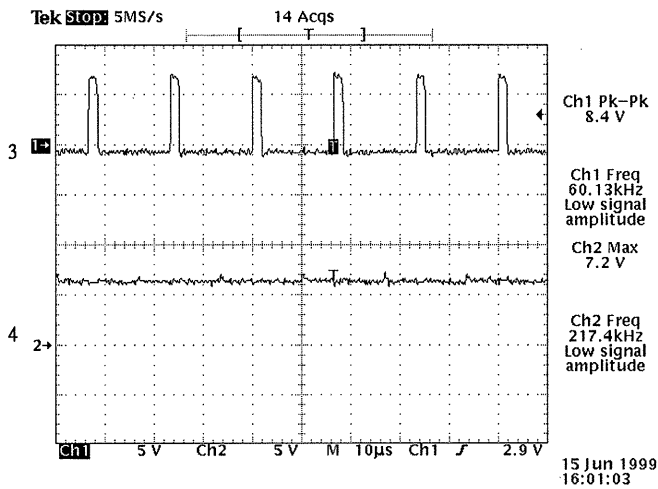
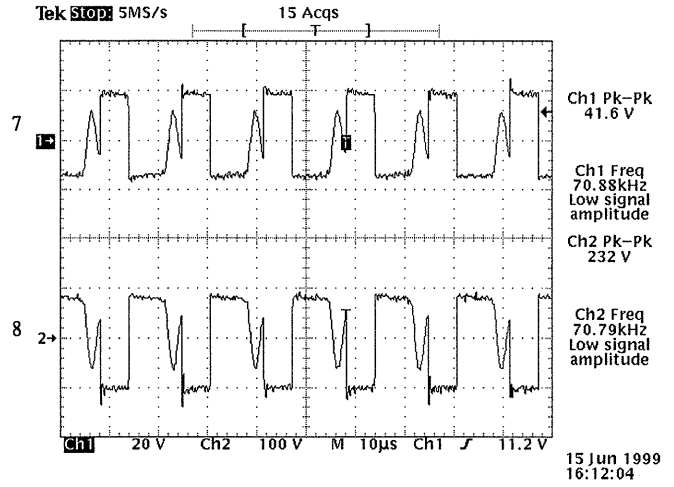
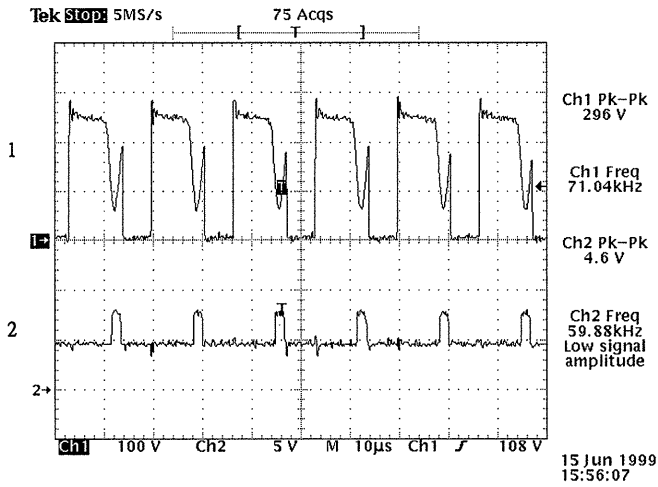

Confidential - Do Not Copy

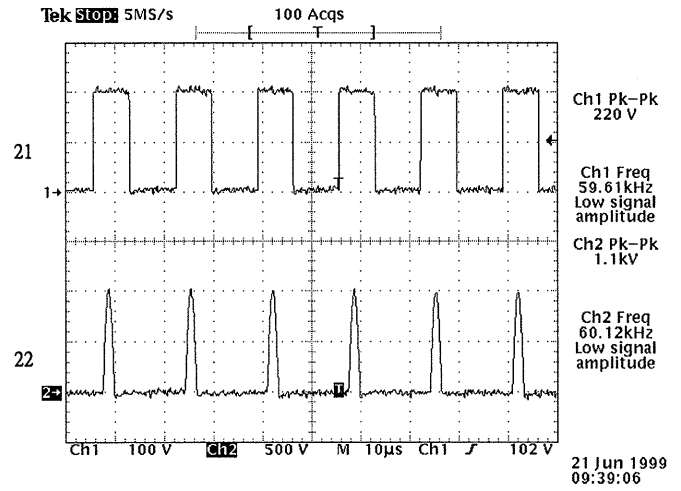
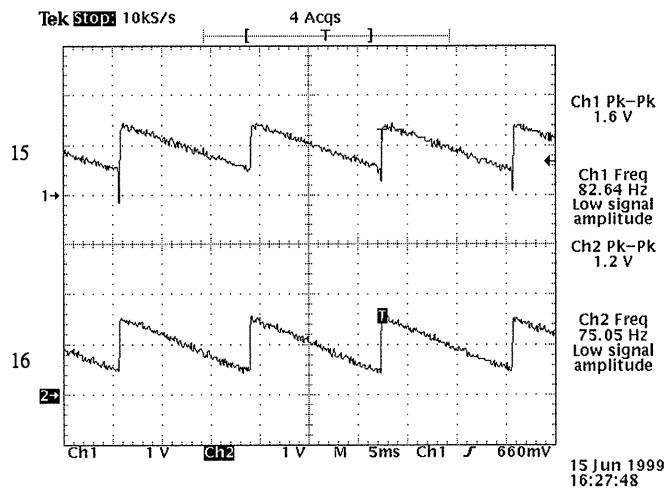
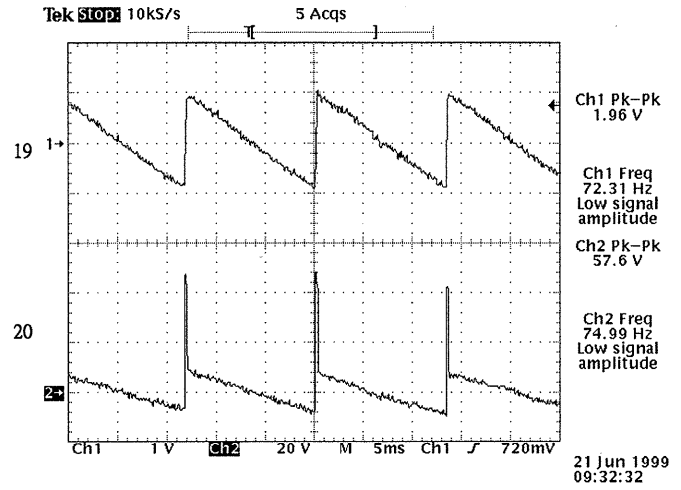
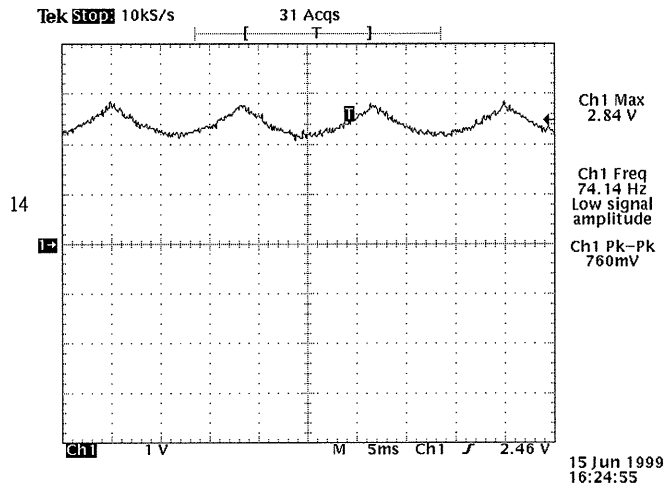
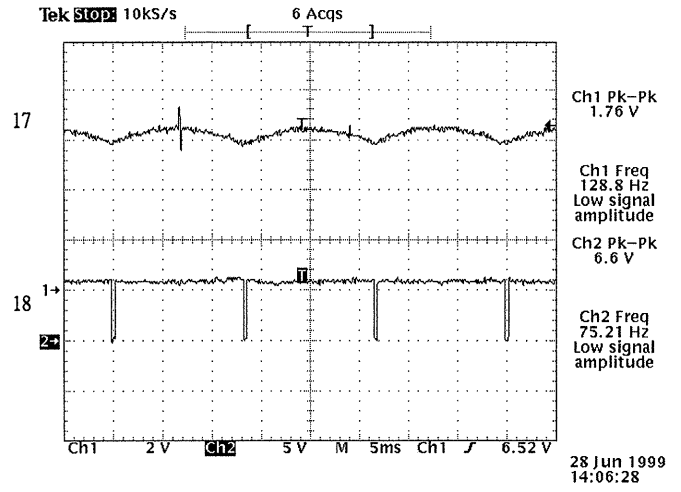
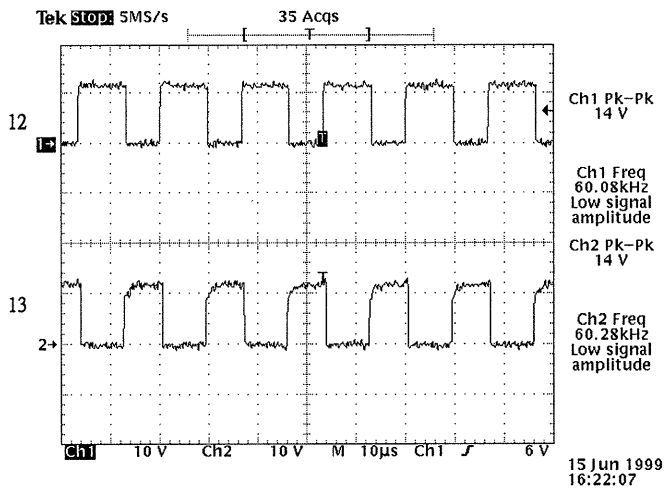

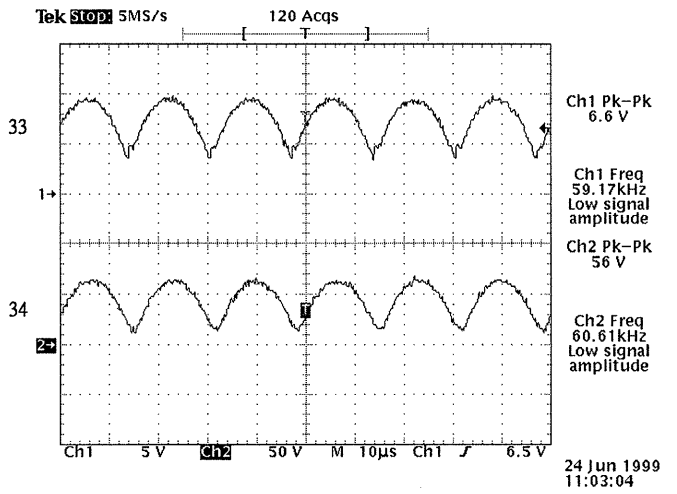
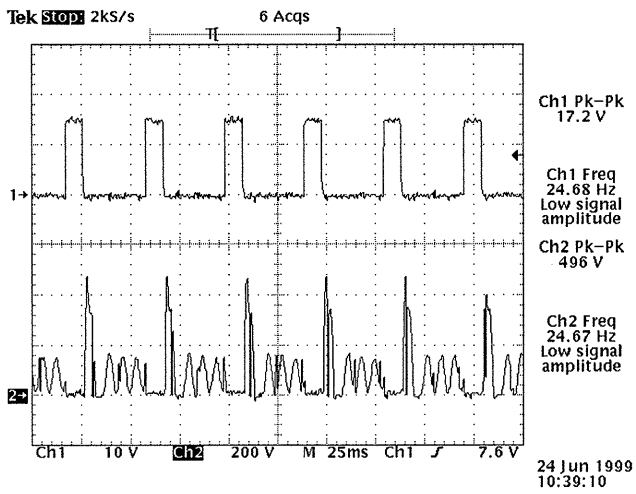
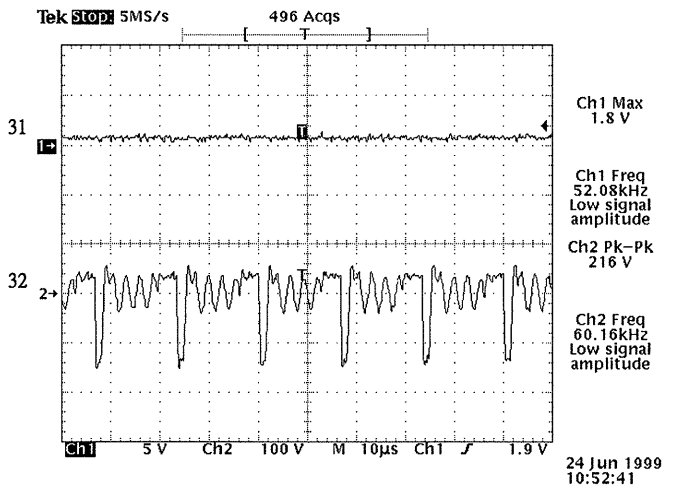
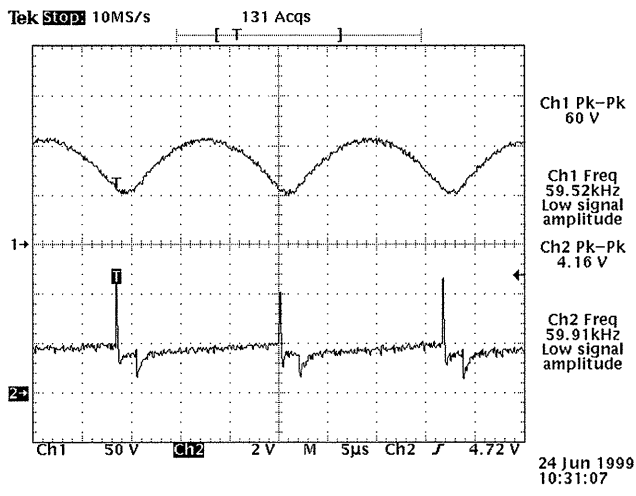
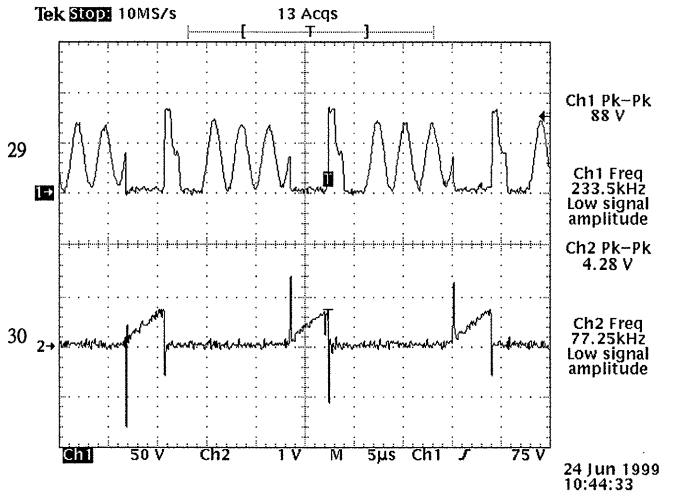
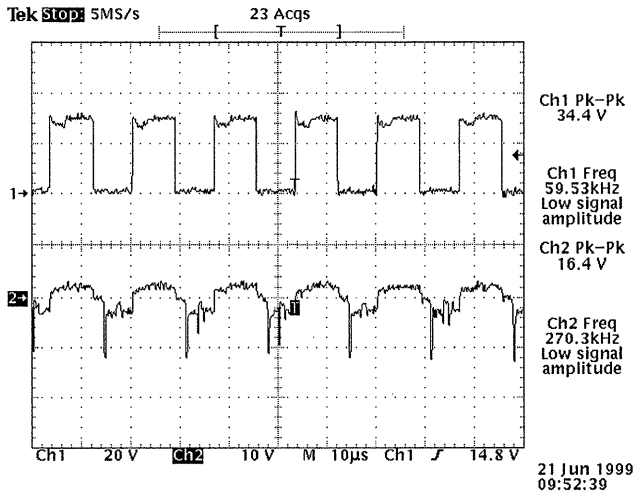

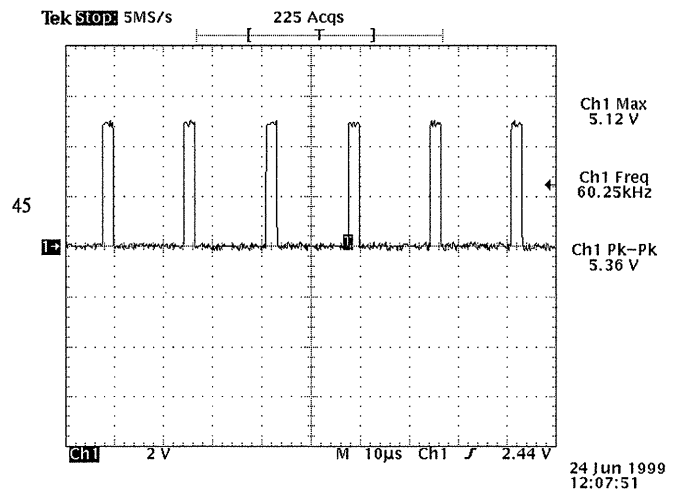
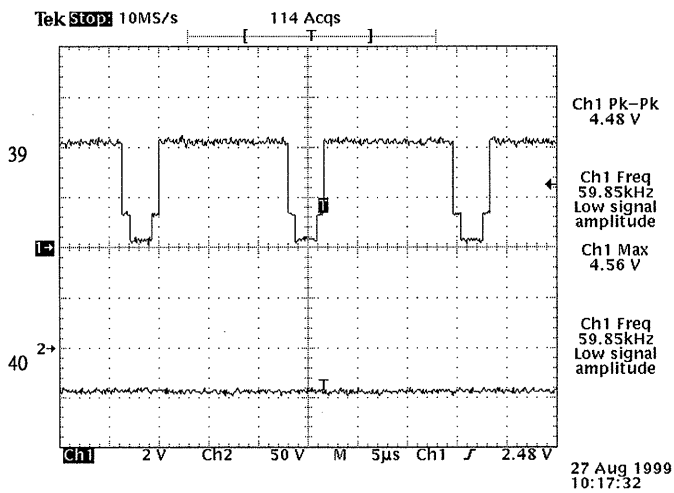
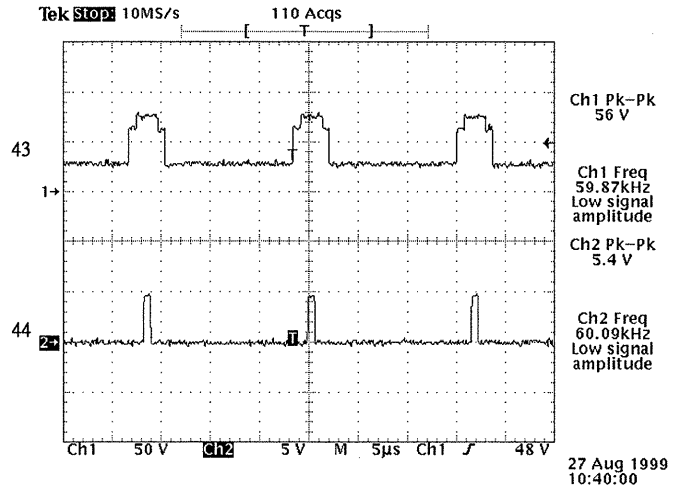
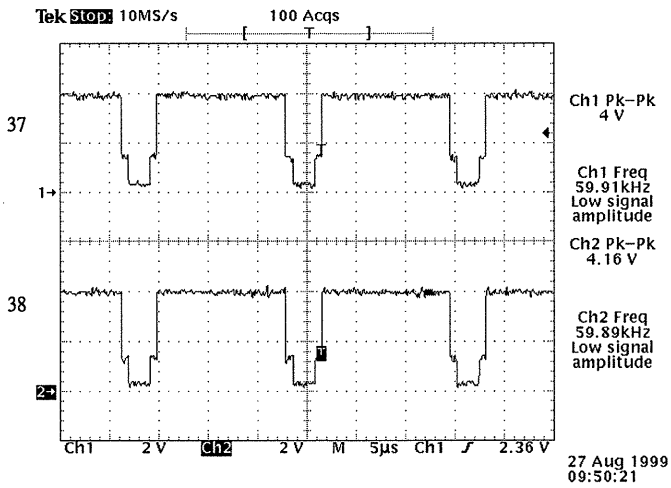
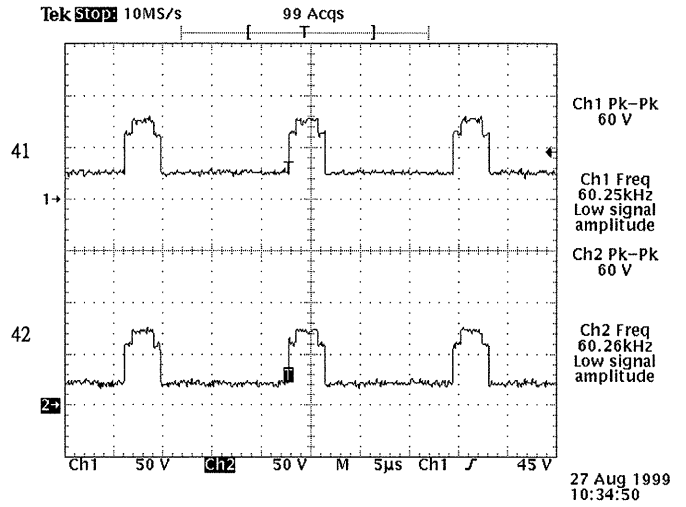
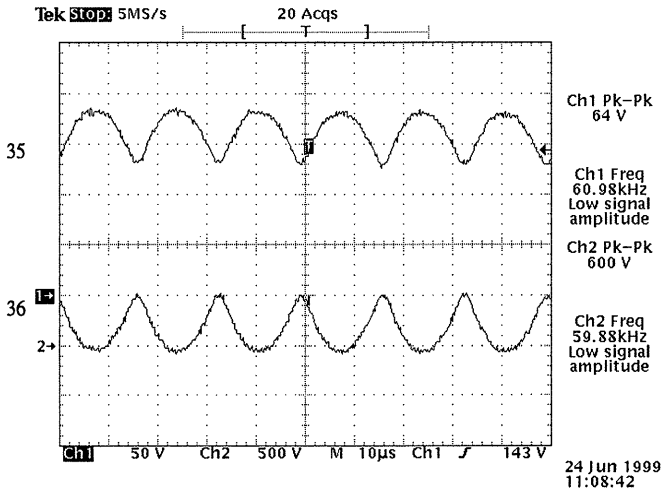

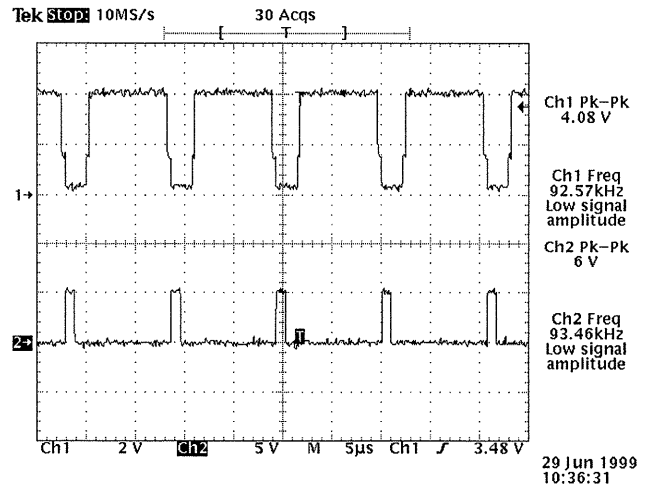
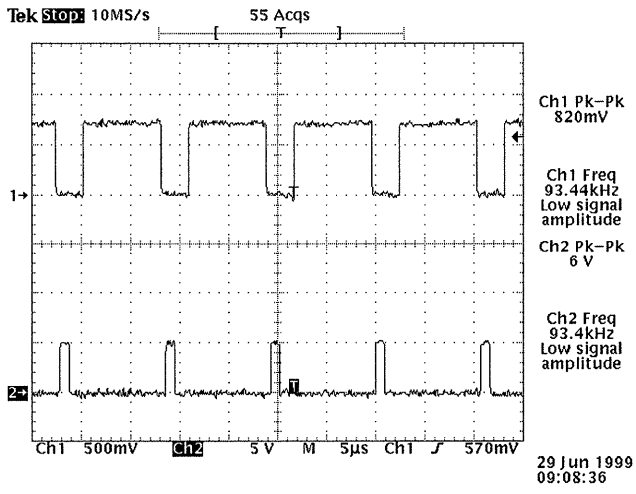

## 4. Circuit description

- 4.1 Power supply ( switching power supply )
- 4.2 Power saving
- 4.3 Micro-controller unit
- 4.4 Sync Processor
- 4.5 Deflection
  - 4.5.1 Horizontal synchronization processing
  - 4.5.2 Horizontal Driver stage
  - 4.5.3 Horizontal scanning and high voltage power supply circuit
  - 4.5.4 Buck converter and width control
  - 4.5.5 The Pincushion /Trapezoid/Top Hook/Bottom Hook correction
  - 4.5.6 Parallel/Pin-balance Control
  - 4.5.7 X-Ray-radiation protection
  - 4.5.8 Vertical Deflection
  - 4.5.9 Focus
  - 4.5.10 Tilt
- 4.6 Video
  - 4.6.1 Video amplifier
  - 4.6.2 On screen Display (OSD)
  - 4.6.3 Auto Beam Limit CKT (A,B,L,CKT)
  - 4.6.4 Brightness control
  - 4.6.5 Blanking CKT
  - 4.6.6 Contrast, gain & Bias control
  - 4.6.7 DDC 1/2B

#### 4. CIRCUIT DESCRIPTION

##### 4.1 POWER SUPPLY (switching mode power supply fly-back type)(IC101)

The raw DC B+ voltage is got from AC input voltage after CR101 rectifier. It supplies lower voltage VCC to PWM controller, IC101 (KA2S1265), through start-up circuit (R104, R120, ZD101, Q102, D113). IC101 is synchronous by T103/Q105/Q109/C110 switching frequency. In order to meet E2000 power consumption specification, during power off mode, IC102 is turned off and Q116 is turned on. It can pull low IC101 pin4 feedback signal to forced power supply shut down. High-frequency & High-Voltage square wave-form is across the primary winding and transfers energy to the secondary. The output DC voltage gets after rectifying and filtering.

In order to have a stable and regulated output voltage while AC input voltage and output load change. IC203 will produce a current change through IC104 couple a voltage change on IC101 pin4. PWM controller circuit will change duty cycle and maintain stable voltage.

The PWM controller IC101 is started up from the raw B+. The lower voltage VCC is provided by T101's AUX-Winding (pin1) through R151, D105, C108, SW101 to IC101 pin3.

The 198V in TP201 can be determinate by R211,R212,R223, VR201  
 $(V_o=2.5 * (R211 + R212 / VR201 + R223)).$

Degauss CKT: When the power is turn on or press manual degauss let IC303 pin13 will high to turn on Q209 and RL201, degauss will active about 4 second.

## 4.2 POWER SAVING

According to E2000 agreement with monitor manufacturer is as the following table:

SYNC. INPUT	H. & V. PRESENTED	NO H. OR V.	NO H. AND V.
MODE	NORMAL	STAND-BY	POWER OFF
TTL SIGNAL	ON	SUSPEND	
SW1	Hi	Lo	Lo
SW2	Hi	Hi	Lo
LED	Green	Amber	Amber
Power (Watt)	Normal	< 15W	< 3W

SW1: IC301 pin24, suspend (SUS)

SW2: IC301 pin23, power down (PD)

- The suspend mode occurs when SW1 is at low level.  
The 15V, 12V, -15V are switch off via Q201 Q202 / Q205 Q206.
- The power-off mode occurs when SW1 and SW2 are at low level.  
The switchine power is turn off and all output are at low output.
- The micro-processor IC301 are drived to power off mode when signal cable is not connected to PC.

## 4.3 MICRO-CONTROLLER UNIT (MCU) (IC301)

IC301 is a 8-bit micro-controller (D1678P40) with 16K byte ROM memory, which play a main role of the digital control monitor. It performs as mode timing detector, key control scanner and controller, DPMS power saving handling, on screen display programmer and auto-alignment geometry controller pin16/17 are for key control. Pin1/40/39 are for s-correction switch control.by IC303 Pin8/9 are for Horizontal and Vertical sync. input respectively. Pin6/7 is the V-sync. and horizontal-sync output to pin14/15 of IC401. Pin39/38 are serial clock and serial data (SCL/SDA) bus communicate with IC302 (EEPROM) pin6/5. Pin16(DSDA)/17 (DSCL) are as a port to communicate with DDC 1/2B access and auto alignment port. by signal cable. Pin21 (U-SDA) / 22(U-SCL) / 20(U-INT) are USB bus.



#### 4.4 SYNC. PROCESSOR

The horizontal sync. is connected from signal cable to IC301(MCU) pin8 input and from IC301 pin7 output positive polarity sync to IC401 pin15.

Vertical sync. is connector from signal cable to IC301(MCU) pin9 input comes out at pin6 a positive polarity sync to IC401 pin14.

The IC301 and the IC401 (TDA4856) sync input can handle either composite or separate sync input.

#### 4.5 DEFLECTION CIRCUIT

##### 4.5.1 Horizontal Synchronization Processing

The horizontal synchronization processor is integrated inside the chip of IC401. It uses a dual phase-lock-loop (PLL1/PLL2) design. This operation ensures a smooth tuning and avoids fast changes of H-frequency during catching.

The processor can synchronize with the input sync. up to triple of free-run frequency which is determined by R408, R409 and C407.

The PLL1 phase detector circuit is used to control the oscillator frequency and maintains it in proper frequency and phase with the incoming sync signal. One input is coupled from output of VCO that is built inside the IC.

A loop filter with a properly selected time constant (C406, R407) is connected at pin26.

The PLL2 circuit is used to compare the line flyback pulse at pin HFLB with the oscillator sawtooth voltage, to compensate the delay in H-deflection by adjusting the PHASE of HDRV. One input is from the output of VCO (which is inside the IC) and a second input (pin1 of IC 401) is from Q415 collector pulse via C483, C484.

The control voltage formed through loop filter is to control horizontal output pulse output at proper duty cycle and maintains the phase between raster and picture.

##### 4.5.2 Horizontal Driver Stage

The horizontal drive pulse from pin8 of IC401 is applied to the base of driver MOSFET Q4125. B<sup>+</sup> is provided by the regulated 15V-voltage source via R446, R446 and C424. The output of driver transformer T401 is coupled to the base of Horizontal output Transistor Q415. R441 C442 compose of damping network, which is to eliminate the leakage flux of T401 during Q412turn off.

#### 4.5.3 Horizontal Scanning and High Voltage Power Supply Circuit

The horizontal scanning is accomplished by Q415, D410, C428, and DY (P401). Except the basic horizontal scan output, Linearity coil T403 corrects the asymmetrical distortion. (C427/C432/C434/C435/C436/C437/C438) are S-Correction capacitors, Q420/Q421/Q422/Q423/Q424 switched on/off according to different H-frequency.

The conducting period of damper diode D410 completes the first half part of horizontal scan. The conducting period of horizontal output transistor Q415 completes the second half of scan.

The retrace capacitor is C428, the charge and discharge actions of retrace capacitor via yoke after Q415 turned off, which is designed for the same resonant frequency with the main scan circuit.

In the high voltage drive circuit, the output of Q401 is applied to the primary winding of flyback transformer (FBT) T401 and drives the flyback transformer to supply CRT anode voltage of about 25.8KV during retrace period. T402 pin6 voltage (B+) steps down by IC402, Q402. Feedback components are C416, R425 and VR402.

Several driven power sources are developed in the FBT secondary, including 40Vp-p: XPR pulse (pin10), -130Vp-p: G1 negative pulse (pin4), 400Vp-p: V Focus VCC (pin3).

#### 4.5.4 Buck Converter and width control

In order to maintain same scan width (raster) within 30KHz-95KHz or 30KHz-86KHz, the scan supply B+ tracked with continuous H-frequency is necessary, and the design is implemented by a convention method-of buck converter. The buck converter mainly composes of a P-channel MOSFET (Q408), choke T402 and rectifier diode D409.

The PWM control circuit is integrated in IC401 pin5 is inverting, pin3 is output of error amplifier, both for frequency compensation and gain setting. PWM pulse width output at pin6 is modulated according to internal error amplifier output. Pin4 current sense is controlled by Q403, R431, ZD401 and R432 for horizontal size width limitation.

#### 4.5.5 The Pincushion/Trapezoid/Top Hook/Bottom Hook Correction

The voltage across R418 can be varied in accordance with a vertical parabolic or sawtooth waveform, which is generated by IC401 pin11. The peak yoke current is decreased in proportion to the feedback of R418, as the voltage across R418 is changed for compensating the pincushion, trapezoid and Hook effect. The waveform is adjusted by IC301 SCL SDA control IC401 pin18 pin 19.

#### 4.5.6 PARALLEL and PIN-BALANCE CONTROL

Parallel CKT is superimposed the vertical sawtooth current inside of IC401 the waveform amplitude is adjust by IC301 SCL SDA control IC401 pin18 pin 19.

Pin-balance CKT is superimposed the vertical parabolic current inside of IC401 the waveform amplitude is adjusted by IC301.

#### 4.5.7 X-RAY-RADIATION PROTECTION

The X-Ray-radiation protection circuit usually uses in the monitor latching type circuit. Therefore, should a fault occur which would activate the X-ray protect circuit, Should a fault occur which would cause the high voltage to increase above a predetermined level, the positive pulse at pin7 of the FBT (T404) would go more positive. This will increase the voltage applied to ZD405 to exceed its breakdown voltage for a certain time. An latch circuit Q434 Q435 switches the IC404 pin1 into protection mode. Shutting down the IC404 and Q437.

NOTE: The X-RAY-Radiation protection circuit used in this monitor is a latching type the monitor will shut down and continue until turn-off the monitor by power switch.

#### 4.5.8 Vertical Deflection (IC501)

Vertical deflection function is operated in the IC401, IC501 that mainly contains the oscillator, ramp generator, and power output amplifier and flyback generator. Vertical oscillator is obtained amplifier by means of an integrator driven by oscillation circuit that is determined by C402, C403 and R406. The vertical sync signal is applied to the pin14 of IC401. Once the sync signal synchronized a clock pulse is generated inside this chip. The clock pulse is just as a sync input of ramp generator. A linear voltage ramp is produced at pin12,13 of IC401, and is couple to IC501 pin1,7 for vertical output amplitude Vertical output amplitude is controlled by R502/R505, IC401 inside parameter and IC301 Vert. size DAC.

The CKT of the TDA8172 provides a high CMRR current driven differential input (pin1,7), the output stages (pin3,5) in a full bridge configuration, a flyback generator, a protection CKT for the output stage and a guard CKT.

The pin5 is the output of the power amplifier and it drives the yoke by a current driven in opposite phase current ramp. Pin2 is the supply voltage 15VDC, Pin4 is supply voltage -15VDC, the pin3 is the feedback pulse feedback to pin6.

Vertical frequency is 100~180Hz, Q401 off so vertical free run is only determined by C402. If vertical frequency is 50~100Hz, Q401 on so vertical free run is determined by C402 + C403. Total vertical frequency range is from 50Hz to 180Hz.

Vertical centering is controlled by changing the DC voltage at vertical output that is caused from the DC shift of IC401 pin13, and that can be adjusted by DAC control of IC301.

#### 4.5.9 FOCUS

Horizontal parabolic wave form the IC901 pin7 (M52723ASP) Sync trigger by the pin17 of IC901. IC901 pin7 is horizontal parabolic O/P to drive Q902, Q903 and Q904 via T405 pin7 coupling to FBT pin13. Vertical parabolic waveform is taken from Q904 via T405 pin1 to FBT pin13. IC901 pin6/pin15 can control IC901 pin7 amplitude/phase by IC301 pin32/pin31.

#### 4.5.10 TILT

Tilt CKT is operated a current of different direction on rotation coil. The IC301 pin33 output 0~5V to IC701 pin2 to control the volt amplitude and polarity on IC701, IC701 pin1 output via Q701 Q702 to drive rotation coil.

### 4.6 VIDEO

#### 4.6.1 VIDEO AMPLIFIER (IC601)

The video amplifier module is composed of three amplifiers for red, green, blue channel.

The video input signal is fed to the video preamplifier IC601 (M52743BSP) (pin2 blue, pin6 green, pin11 red) through AC coupling capacitor C603, C604, C658.

The clamping pulse comes from IC301 pin28 to IC601 pin19. The blanking pulse come from P602 pin9 (HBL) and P604 pin3(VBL) to IC601 pin27.

IC602 is an integrated high voltage CRT driver circuit designed to drive R.G.B channel of CRT

#### 4.6.2 On Screen Display (OSD)(IC603)

IC603 (MTV021N-25) is a on screen display generator. Pin5 for H-sync input, pin10 for V-sync input. The IC603 is controlled by IC301 via P604 ISCL, ISDA to IC603 pin7, pin8.

The on screen display signal is output from pin12 (B), pin15(G), pin14(R), pin13(B)connected to mixer circuit of IC601 pin1, pini4, pin13, pin9.

#### 4.6.3 Auto Beam Limit CKT (A. B. L. CKT)

When beam current over 870uA by VR401, the voltage build at base of Q601 will be less then 3.5V, then the voltage of pin15 of IC601 will be pulled down accordingly to reduce the video preamplifier gain output.

#### 4.6.4 **Brightness Control**

Brightness (G1) is controlled by varying the DC voltage of VR601 and the IC601 pin23 (DAC) voltage.

#### 4.6.5 **Blanking CKT**

From IC301 pin6 and IC501 pin6 vertical blanking pulse are fed to the base of Q501 and via P604 pin3. The blanking pulse O/P is coupled to horizontal blanking pulse by Q614. Horizontal & vertical blanking pulse are fed to IC601 pin27 and let video O/P Amp cut off during the period of horizontal retraces. While mode change. IC301 pin15 will pull high to turn on Q612 (mute function) and Q613 will be off. The G1 volt will down to -130V then CRT will cut off the video output.

#### 4.6.6 **CONTRAST, GAIN & BIAS CONTROL**

The IC601 contains three gated single ended input black level clamp compurgators for brightness control, three matched DC controlled attenuators for contrast control, and three DC controlled sub-contrast attenuators providing gain trim capability for white balance.

All the DC control voltages are comes from IC601 internal (DAC) is controlled by IC301 Micro controller via a serial bus. The IC601 DAC output pin24, 25, 26 for G.R.B (BIAS) controller.

#### 4.6.7 **DDC1/2B**

IC604 (24LC21) can transmit continuously it's extended identification, "EDID" using DDC1 communication channel. In addition, the monitor can respond to a regrets for EDID, or complete VDIF, to be transmitted using DDC2, level B commands. Pin6 (DSCL) is clock input for DDC 2B, pin5 (DSDA) for data input. Pin7 (V-sync) is clock input for DDC1 through V-sync.

In DDC1 data transfer (UNI-directional mode) the V sync input pin is used as input clock for data transmission and SDA output pin as serial data line the SCL pin will hold high.

The DDC2B mode (BI - directional mode), BUS consists of two wires SCL is for the data transmission clock and SDA is for the data link.

## **5. Adjusting procedure**

### **A. General.**

### **B. Instrument alignment.**

1. Deflection presets.
2. Power supply alignment.
3. Size & geometry adjustment.
4. Video alignment / function memory recall.
5. Focus adjustment.

### **C. PCB defined.**

### **D. Fixture function description.**

## General

1. All specification must be met over line voltage range of 90VAC to 264VAC 50Hz/60Hz unless other wise specified.
2. Operating temperature range is 0 DEG.C to 40DEG. C with a relative humidity of 10% or less to 95%.
3. The monitor must be operational in an unstable state within 30 section after turn-on.
4. All signal levels are measured assuming termination at the monitor's input jacks or in its characteristic impedance.
5. An ambient lighting level of 400 to 600 LUX is assumed when setting brightness for raster extinction threshold.
6. All purity related specifications must be met without external degaussing.
7. All controls must have excess range (No control may be left at an end stop when proper alignment is completed).
8. The monitor is not required to meet specs during the following but must tolerate, without damage to the CRT or circuits, Any sequence or combination of power on and off, signal on and off, unplugging of power or signal, erratic, Wrong frequency of inputs while at any possible settings of user accessible controls noisy
9. An isolation transformer should be used when performing alignment and tests. Portions of the power supply board are hot ground The remaining boards are cold ground
10. Discharge of CRT anode should be done only to CRT ground strap.
11. Geometric measurement are assumed to be made alone a straight surface with a flat rule or template.

## A. Instrument alignment

1. **Deflection presets**

- 1.1 Control pots (VR201, VR401, VR402, VR403 ) are set at middle point. screen VR set to MIN.

2. **Power supply alignment**

- 2.1 Input VESA 1024x768 / 75Hz mode & cross-hatch pattern.
- 2.2 Adjust VR201 until voltage at TP201=198V $\pm$  0.2V.

3. **Extreme High Tension (EHT) Alignment (High Voltage)**

- 3.1 Input VESA640x480 31.5KHz/60Hz mode & cross-hatch pattern.
- 3.2 Contrast 100%, brightness 50%.

Adjust VR402 let H.V=27  $\pm$  0.1KV (G90f)

Adjust screen (G2 knob)let G2 POINT = 580 $\pm$ 10VDC (G90f)

Adjust focus to be optimal (G3 / G5 knobs)

#### 4. Horizontal alignment

##### 4.1 Raster centering

- 4.1.1 Input test signal VESA1024x768 / 75Hz mode & cross-hatch pattern.
- 4.1.2 Contrast 0%, Brightness 100%.
- 4.1.3 Press select the OSD to "RCENTER".
- 4.1.4 Adjust "RCENTER" ▲/▼ to center raster on screen such that the horizontal distance from the left display edge to the left bezel edge is within 3mm of the distance from the right display edge to the right bezel

##### 4.1.5 Edge.

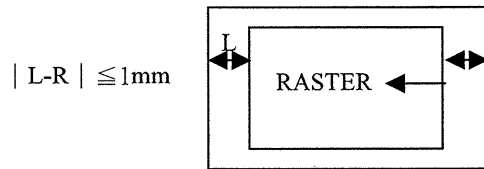

- 4.1.6 Change input test signal VGA 640x480 / 60HZ mode & cross-hatch pattern.
- 4.1.7 Select the OSD to "H-SIZE".
- 4.1.8 Adjust "H-SIZE" ▲/▼ to narrow the raster size on screen such that the horizontal distance at the right and left edge is within 5mm.
- 4.1.9 Adjust "RCENTER" ▲/▼ to center raster on screen such that the horizontal distance from the left display edge to the left bezel edge is within 3mm of the distance from the right display edge to the right bezel edge.

##### 4.2 Picture centering

- 4.2.1 Input test signal VESA 1024x768 / 85Hz MODE & cross-hatch pattern.
- 4.2.2 Contrast 100%, Brightness 100%, cross-hatch pattern.
- 4.2.3 Adjust "H-PHASE" such that the picture is centered with the raster.
- 4.2.4 Adjust "H-SIZE" such that the picture size is 357mmX268mm.
- 4.3 Geometry distortion : PINCUSHION, PIN-BALANCE, TRAPEZOID, PARALLEL,TILT, TOP HOOK, BOTTOM HOOK.
- 4.3.1 Input test signal VESA 1024x768 / 85Hz mode & cross-hatch pattern.
- 4.3.2 Adjust "PINCUSHION" such that PINCUSHION / BARREL distortion of the nominal rectangle specified.



4.3.3 Trapezoid / Parallelogram / TOP & Bottom hook / tilt adjustment.

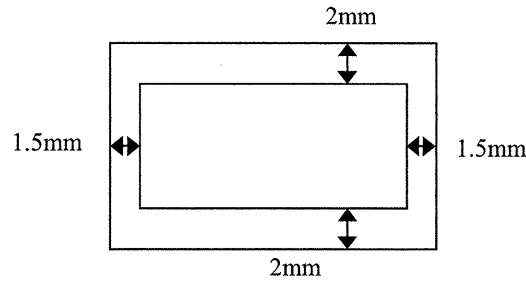

4.3.4 Geometry distortion must limit as above diagram.

4.4 Picture width

4.4.1 Input preset timing adjust,H-SIZE (OSD) to achieve  $357 \pm 4\text{mm}$ .

5. Vertical section adjustments.

5.1 Centering(with magnetic filed)

5.1.1 Apply signal at VESA 1024x768 / 75Hz mode, cross-hatch pattern.

5.1.1 Adjust “V-CENTER” to the video display vertically such that the vertical distance from the center of picture to the top bezel edge and the bottom bezel edge is within 3mm.

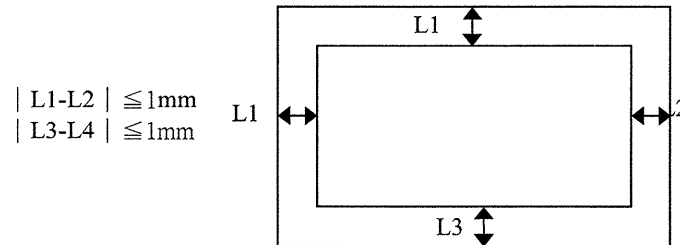

5.2 Vertical size

5.2.1 Apply preset timing cross-hatch pattern.

5.2.2 Adjust “V-SIZE” such that vertical height is  $268\text{mm} \pm 1\text{mm}$ .

6.0 Dynamic focus adjustment

6.1 Dynamic focus phase adjustment

6.1.1 Apply VESA1280x1024 80KHz / 75Hz mode full white pattern.

6.1.2 Connect oscilloscope across T404 pin13 on PCB-MAIN with GND Display size width: 357mm, height 268mm.

6.1.3 The OSD select FACTORY DEFLECTION to “FOCUSPHASE”.

- 6.1.4 Adjust FOCUSPHASE to get horizontal parabolic waveform at center with video signal center by pressing adjust “▲” and “▼”.

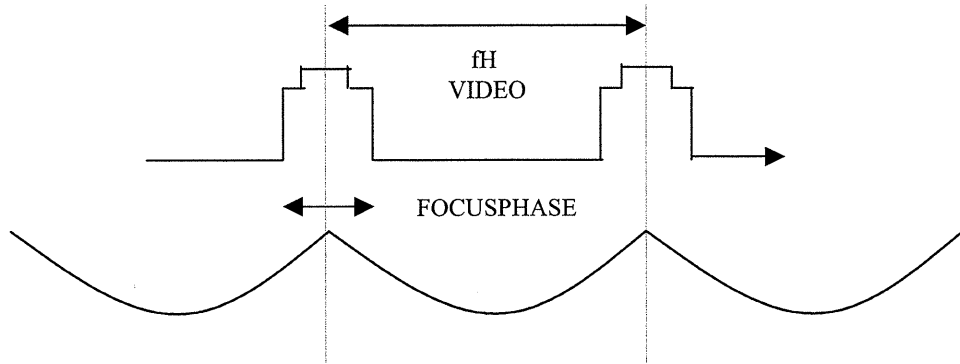

6.2 Dynamic focus parabolic waveform adjustment

- 6.2.1 Apply 30KHz / 50Hz, 95KHz / 150Hz timing display size width: 357mm, height: 268mm , H-FOCUS = 50% , V-FOCUS = 50%.
- 6.2.2 Input VGA640x480 / 60Hz full white pattern
- 6.2.3 Select FACTORY PARAMETER to 31KHZ.
- 6.2.4 Adjust horizontal parabolic waveform to get  $370 \pm 10Vp-p$  by pressing adjust “▲” and “▼”.

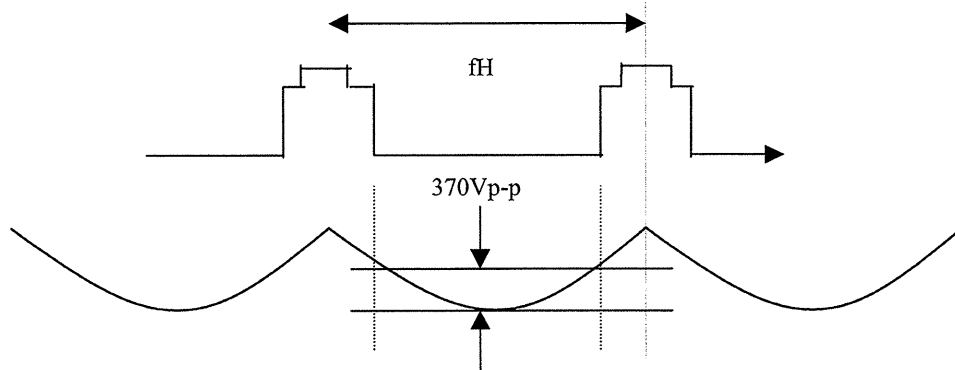

- 6.2.5 Input 30KHZ/ 50HZ full white pattern, select FACTORY PARAMETER to 50Hz.
- 6.2.6 Adjust vertical parabolic waveform to get  $170Vp-p \pm 5Vp-p$  by pressing adjust “▲” and “▼”.
- 6.2.7 Input VESA1600x1200/75Hz full white pattern.
- 6.2.8 The OSD select FACTORY PARAMETER to 95KHz.
- 6.2.9 Adjust horizontal parabolic waveform to get  $370 \pm 10Vp-p$  by pressing adjust “▲” and “▼”.
- 6.2.10 Input 95KHz / 150Hz full white pattern, the OSD select FACTORY PARAMETER to 150Hz.

6.2.11 Adjust vertical parabolic waveform to get  $170\text{Vp-p} \pm 5\text{Vp-p}$  by pressing adjust “▲” and “▼”.

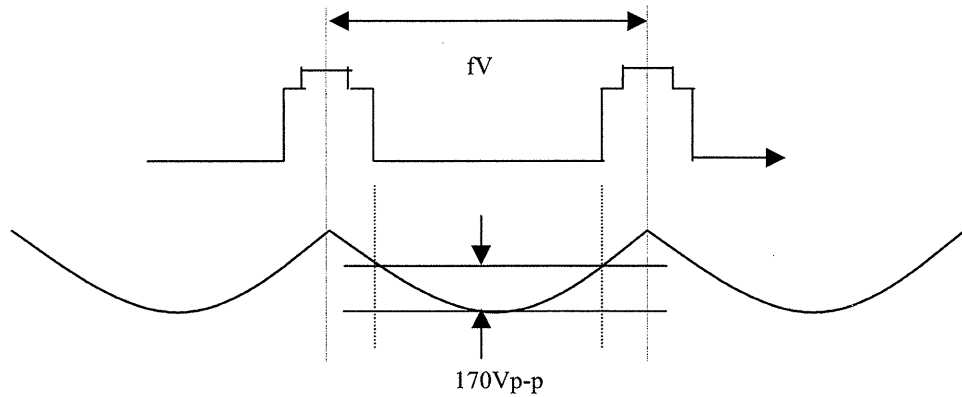

## 7. Focus adjustment

- 7.1 Set BRIGHTNESS at 50% AND CONTRAST at 100%.
- 7.2 Apply signal (all “ME” pattern) at VESA1024x768 / 75Hz mode.
- 7.3 Disconnect the RED and BLUE video input so as to produce a green only screen.
- 7.4 Set FOCUS CONTROL F1, F2 for best focus at midpoint of diagonal line from 10:00 corner to center of screen. F1 control for VERTICAL LINE; F2 control for HORIZONTAL LINE; individual; pixels should be distinguishable over entire display area.

## 8. Video preset condition

- 8.1 Apply VESA 1024x768 / 75Hz.
- 8.2 Display size width:  $357 \pm 4\text{mm}$ , height:  $268 \pm 4\text{mm}$ .
- 8.3 C ONTRAST 100
- 8.4 BRIGHTNESS “100”
- 8.5 RCUT, GCUT , BCUT “30”
- 8.6 RGAIN, GGAIN, BGAIN “200”
- 8.7 G1 “100” (Range 50 ~ 205)

## 9. Video alignment

- 9.1 Video cut off adjustment
  - 9.1.1 Adjust VR601 to get the raster  $0.5 \sim 0.7\text{FLS}$  (Center =  $0.6\text{FLS}$ ) – G90f.
  - 9.1.2 Adjust “RCUT”, “GCUT”, “BCUT” to get color coordination.  
 $x=0.283 \pm 0.010$ ,  $y=0.297 \pm 0.010$

- 9.1.3 Adjust "VR601" to get the raster  $Y=0.85 \pm 0.2\text{FLS}$  (G90f)  
 $Y=0.6 \pm 0.2\text{FLS}$  (A90-2)
- 9.1.4 Ensure that color coordination is  $x=0.283\pm0.010$ ,  $y=0.297\pm0.010$ , if color coordination out specification, repeatedly item 9.1.1~9.1.3, until it meet specification.
- 9.1.5 Adjust R.G.B BIAS control to meet following chromatically spec.  
9300°K→  $x = 0.283\pm0.010$  ,  $y = 0.297\pm0.010$  ,  $Y = 0.85 \pm 0.2\text{FLS}$  (G90f)  
 $Y = 0.6 \pm 0.2\text{FLS}$  (A90-2)  
6500°K→  $x = 0.311\pm0.010$  ,  $y = 0.329\pm0.010$   
5000°K→  $x = 0.346\pm0.010$  ,  $y = 0.359\pm0.010$

9.2 Brightness and white balance adjustment

- 9.2.1 Set VESA 1024x768 / 75Hz window pattern, CONTRAST = 100% BRIGHTNESS = 50%.
- 9.2.2 Apply green white window pattern adjust G-DRIVER to obtain GREEN window pattern light output about  $Y = 30\pm2$  FLS.
- 9.2.3 Apply white window pattern, adjust R-DRIVER, B-DRIVER to meet following chromatically spec. after G-DRIVER fixed.  
9300°K →  $x = 0.283\pm0.010$  ,  $y = 0.297\pm0.010$
- 9.2.4 Get  $Y = 40 \pm 1$  FLS
- 9.2.5 Apply GREEN white window pattern light output about ( $Y = 24 \pm 2$  FLS).
- 9.2.6 Apply white window pattern, adjust R-DRIVER, B-DRIVER following chromatically spec. after G- DRIVER fixed.  
6500°K→  $x = 0.313 \pm 0.010$  ,  $y = 0.329 \pm 0.010$
- 9.2.7 Apply GREEN white window pattern, adjust G-DRIVER to obtain GREEN window pattern light O/P about ( $Y = 20\pm2$  FLS).
- 9.2.8 Apply WHITE window pattern ,adjust R-DRIVER, B-DRIVER to meet following chromatically spec after G-DRIVER fixed.  
5000°K→  $x = 0.346\pm0.010$  ,  $y = 0.359\pm0.010$

- 9.3 Apply full WHITE pattern, adjust VR403 to get  $Y = 30\pm2$  FLS and check the chromatically meet following spec.

9300°K only for 1024x768 / 75Hz

$$| x ( Y=\text{MAX}) - x ( Y = 10) | \leq 0.010$$

$$| y ( Y=\text{MAX}) - y ( Y = 10) | \leq 0.010$$

**10. X-RAY adjustment/FACTORY MODE disable**

10.1 X-RAY adjustment & check

10.1.1 Input 640X480 / 31.5Kz mode, cross-hatch pattern.

10.1.2 Set CONTRAST 100%, BRIGHTNESS 50%.

10.1.3 Use 47K 1% parallel with R4123 12K (P402).

10.1.4 Adjust VR401 let picture shut down.

10.1.5 Use 60K 1% parallel with R4123 12K 1% (P402) , the picture must be OK.

10.2 Factory mode enable/disable

10.2.1 Press “ENTER” key until push power knob on/off four times that can enable factory mode. If press “▲” key until push power knob one time that can disable factory mode.

10.2.2 Press “▼”key until push power knob four times, that can enable burning mode and can use fixture to adjust picture. If press r “MENU” key until push power knob one time, that can disable burning mode.

**D. Fixture Function Description**

1. Fixture adjust.

Adjust Program		
H . Position	<input type="text" value="255"/>	Rotation <input type="text" value="255"/>
H. Size	<input type="text" value="255"/>	HDBF_31K <input type="text" value="255"/>
V . Position	<input type="text" value="255"/>	HDBF_95K <input type="text" value="255"/>
V . Size	<input type="text" value="255"/>	VDBF_50Hz <input type="text" value="255"/>
Sidepin	<input type="text" value="255"/>	VDBF_150 <input type="text" value="255"/>
PinBalance	<input type="text" value="255"/>	Rotation <input type="text" value="255"/>
Keystone	<input type="text" value="255"/>	Rotation <input type="text" value="255"/>
Parallel	<input type="text" value="255"/>	Rotation <input type="text" value="255"/>
TopCorner	<input type="text" value="255"/>	Rotation <input type="text" value="255"/>
BomCorner	<input type="text" value="255"/>	Rotation <input type="text" value="255"/>
TopBalance	<input type="text" value="255"/>	Rotation <input type="text" value="255"/>
BomBalance	<input type="text" value="255"/>	
H_Moire	<input type="text" value="255"/>	G1V_Fine <input type="text" value="255"/>
V_Moire	<input type="text" value="255"/>	Contrast <input type="text" value="255"/>
H_Focus	<input type="text" value="255"/>	Brightness <input type="text" value="255"/>
Raster	<input type="text" value="255"/>	R Drive <input type="text" value="255"/>
Hliner	<input type="text" value="255"/>	G Drive <input type="text" value="255"/>
FocusPhase	<input type="text" value="255"/>	<input type="text" value="255"/>
		B Drive <input type="text" value="255"/>
		R Cut-Off <input type="text" value="255"/>
		G Cut-Off <input type="text" value="255"/>
		B Cut-Off <input type="text" value="255"/>
		<input type="button" value="Get Data"/>
		<input type="button" value="Get 9300"/>
		<input type="button" value="Get 6500"/>
		<input type="button" value="Get 5000"/>
		<input type="button" value="Save Geometry"/>
		<input type="button" value="Save Parameter"/>
		<input type="button" value="Save Color"/>

2. Command define.

- 2.1 Loading initial data file : File -> Open -> select file -> open
- 2.2 Write initial data to monitor : Monitor -> write\_eep .
- 2.3 Get data : Read E<sup>2</sup>PROM data (one mode adjustment value).
- 2.4 Get 9300 : get color 9300K to adjust .
- 2.5 Get 6500 : get color 6500K to adjust ..
- 2.6 Get 5000 : get color 5000K to adjust .
- 2.7 Save color : save current color temperature data .
- 2.6 Save geometry : Save geometry adjustment data.
- 2.7 Save parameter : Save adjustment data to E<sup>2</sup>PROM.

3. Fixture Connect.

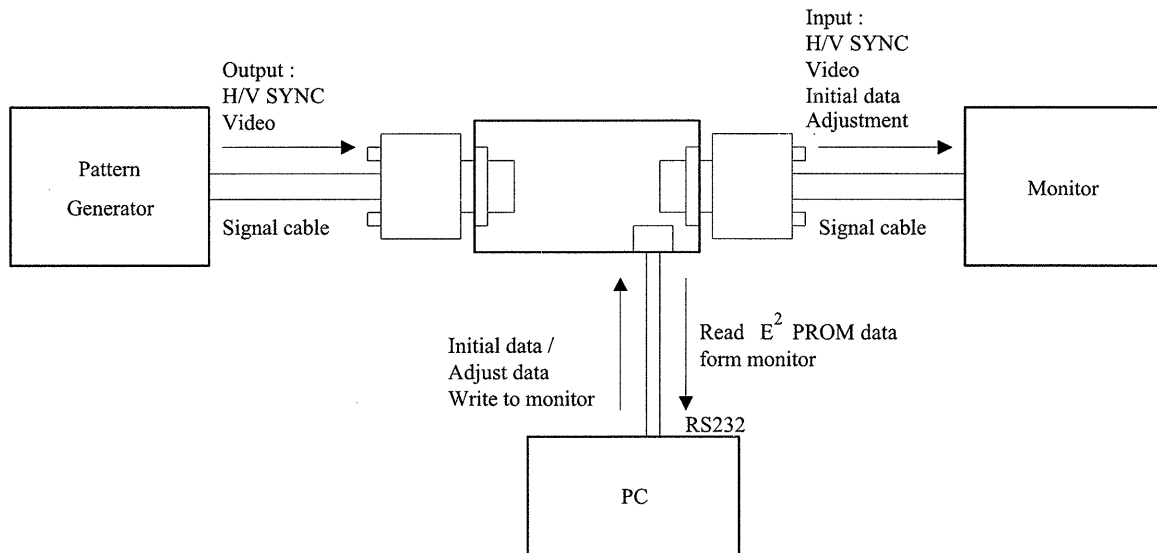

## **6. Trouble shooting flow chart**

- 1. Power supply is defective**
- 2. Horizontal deflection circuit is defective**
- 3. The raster don't appear**
- 4. Vertical deflection is defective**
- 5. Video is defective**

1. Power supply is defective

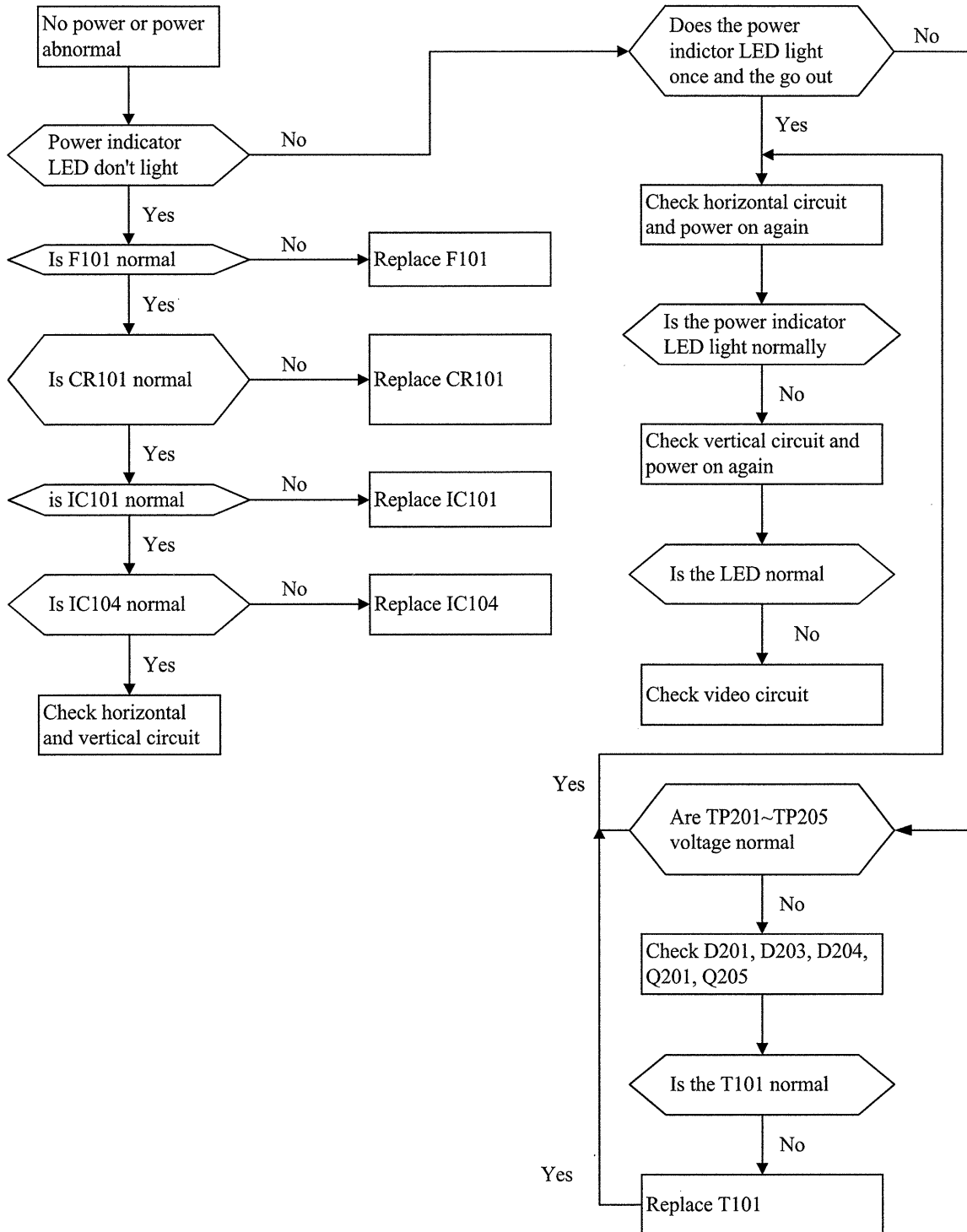



2. Horizontal deflection circuit is defective

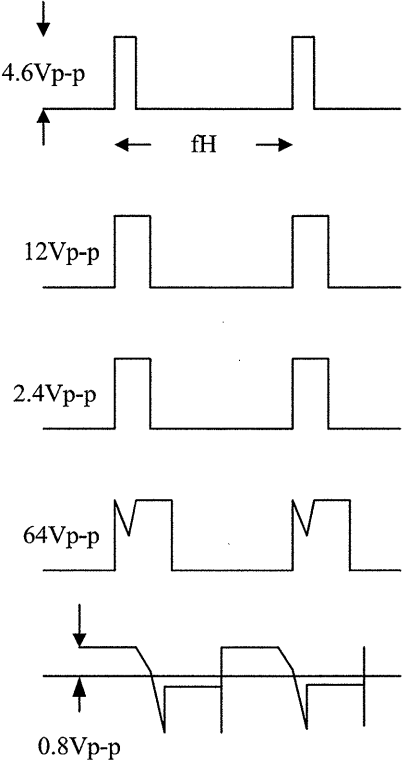
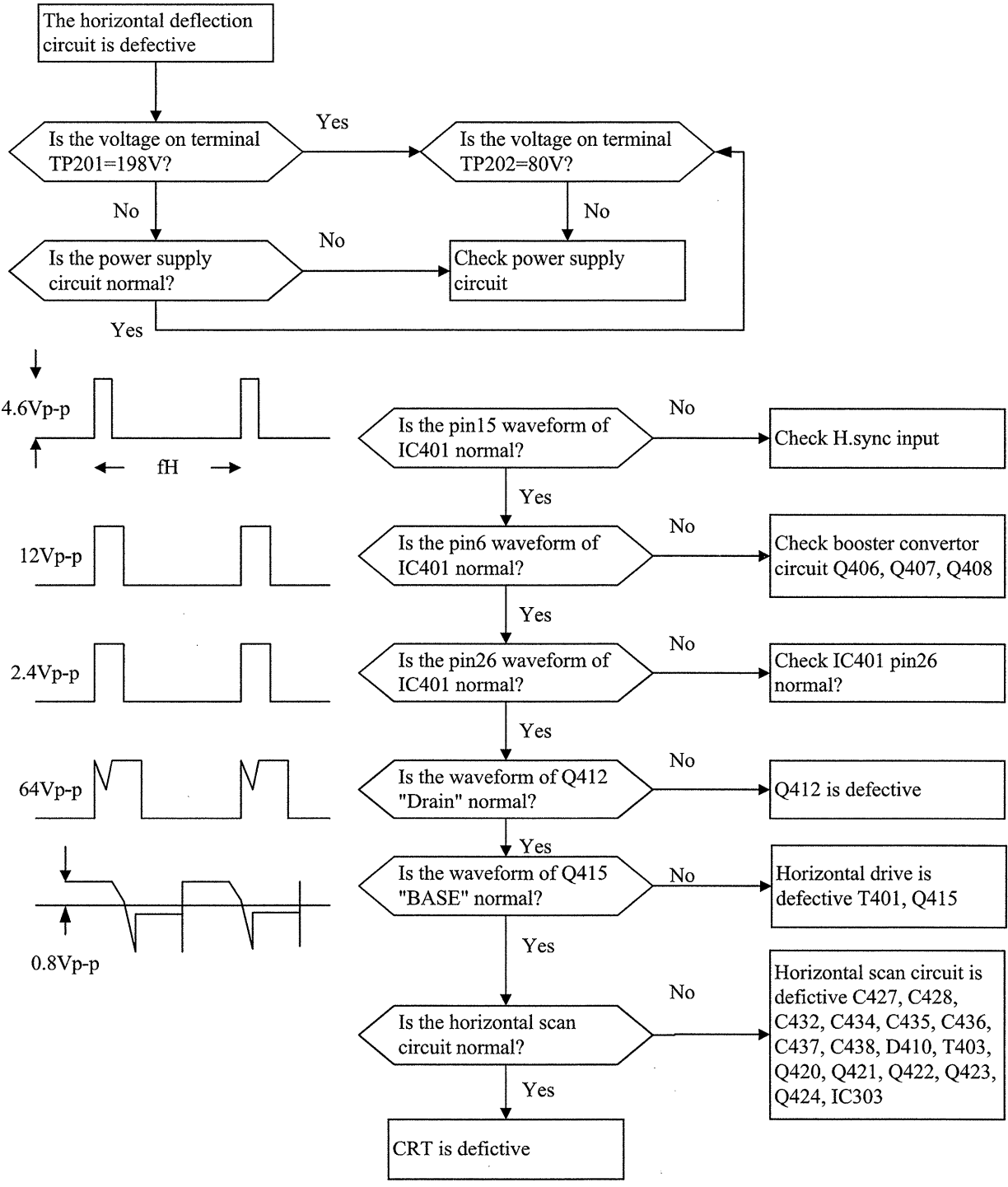

3. The raster don't appear

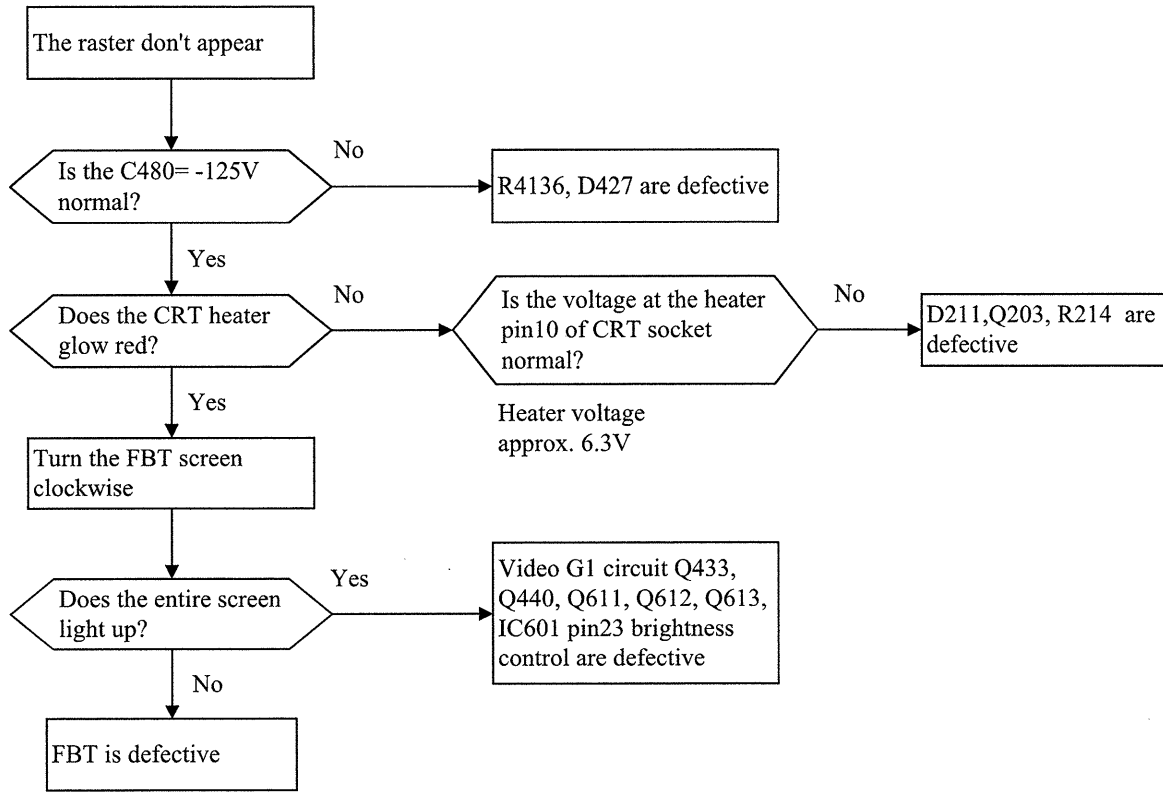

4. Vertical deflection is defective

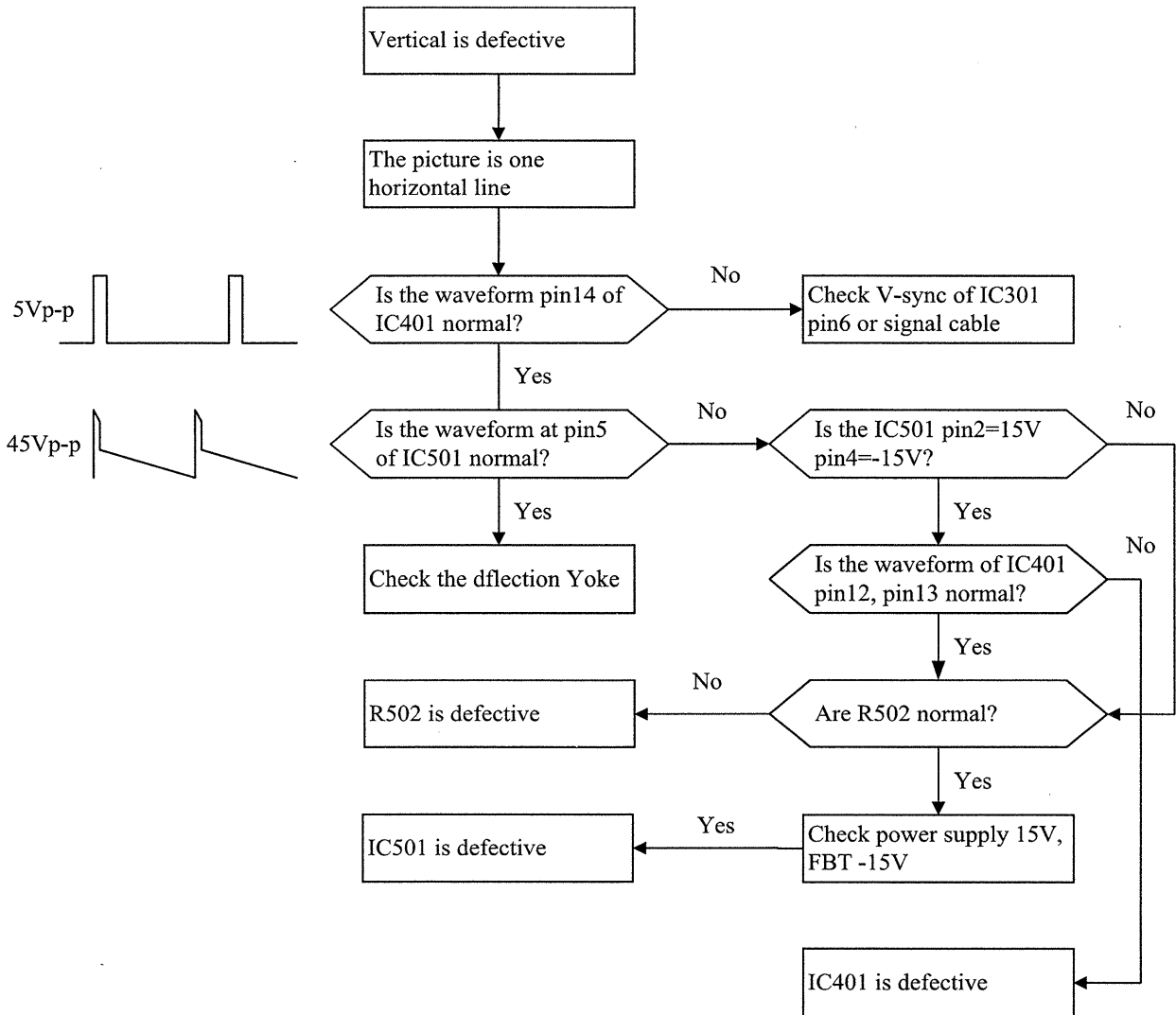

5. Video is defective

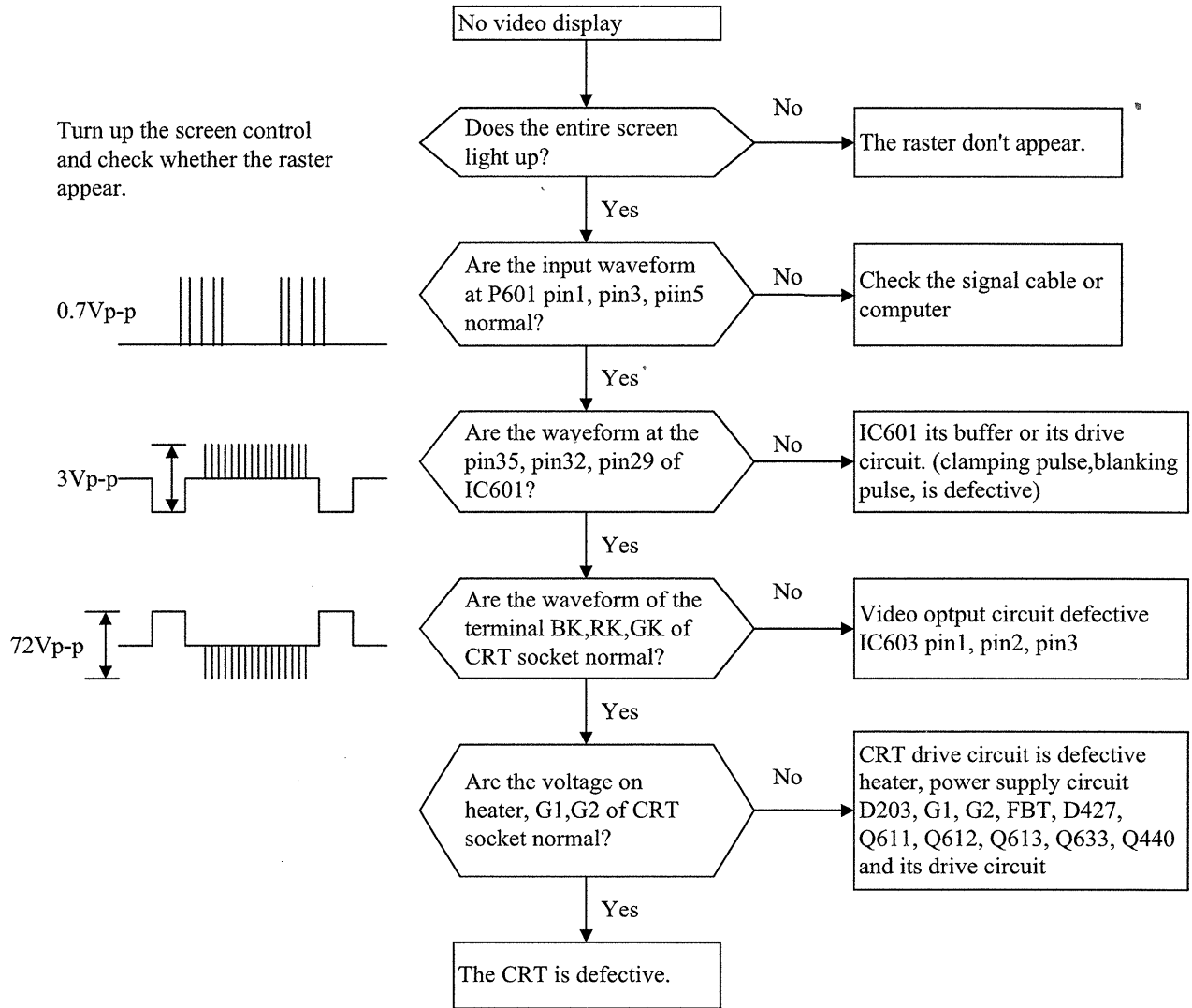

6. One Color missing

turn up the screen control and check whether the raster appear.

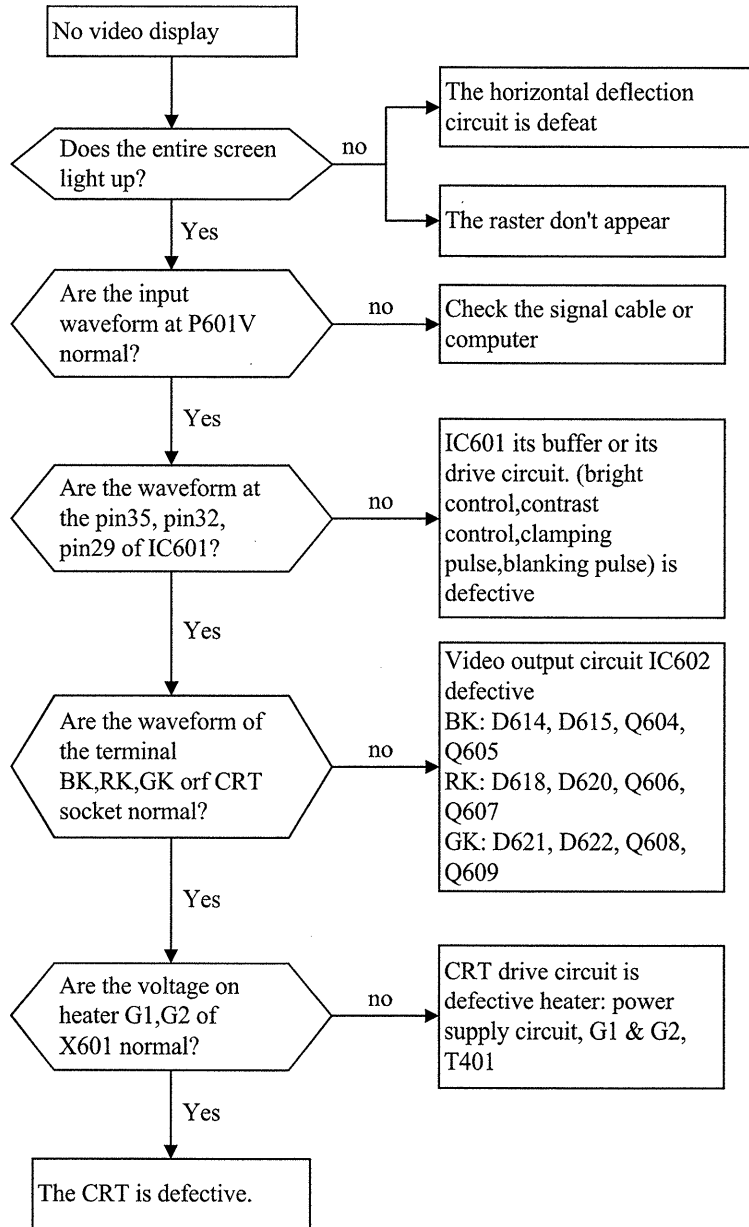

7. OSD is Defective

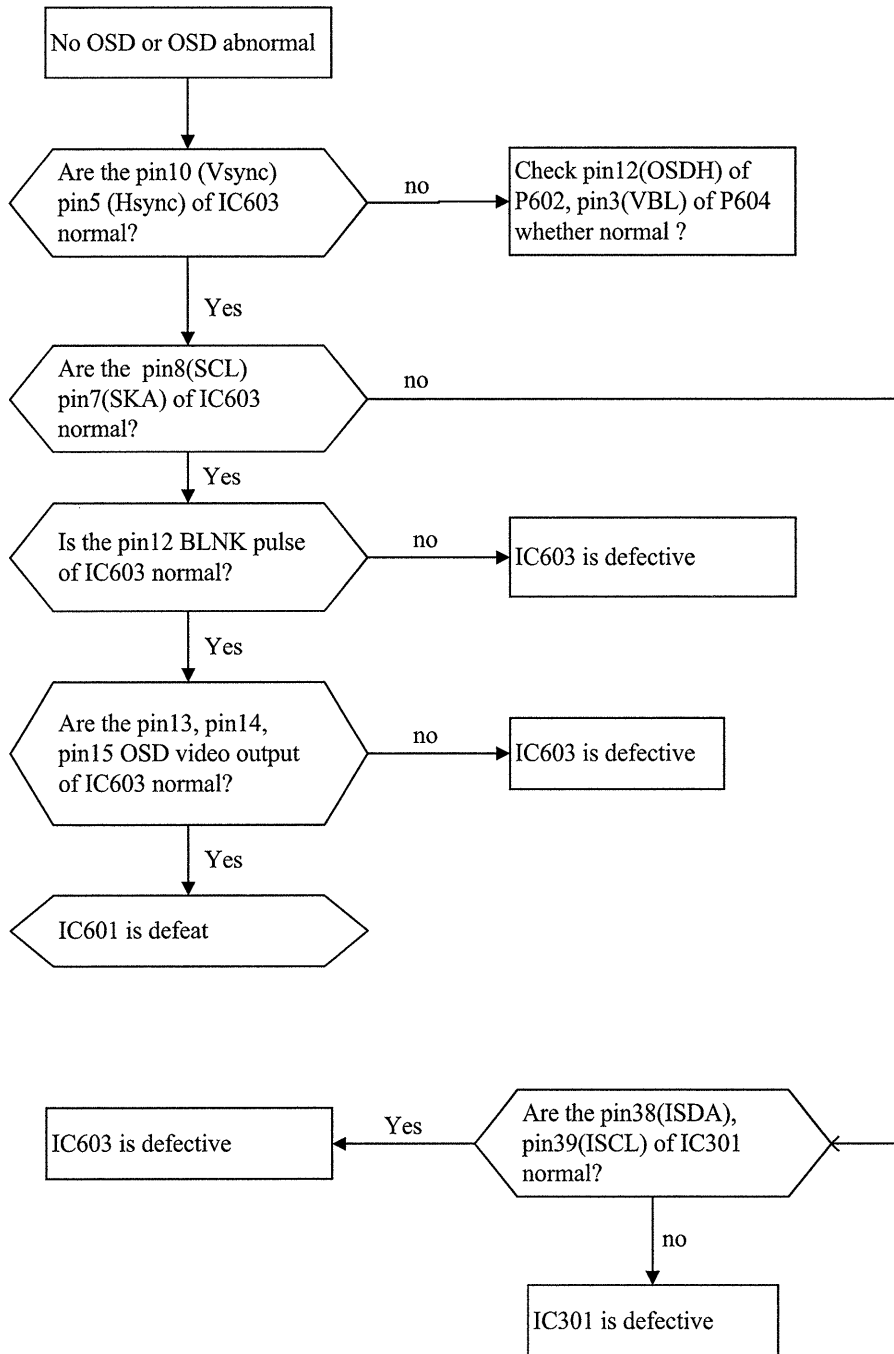

## **7. Mechanical assembly**

### **1. G90f/A90-2 assembly diagram**

1 2 3 4

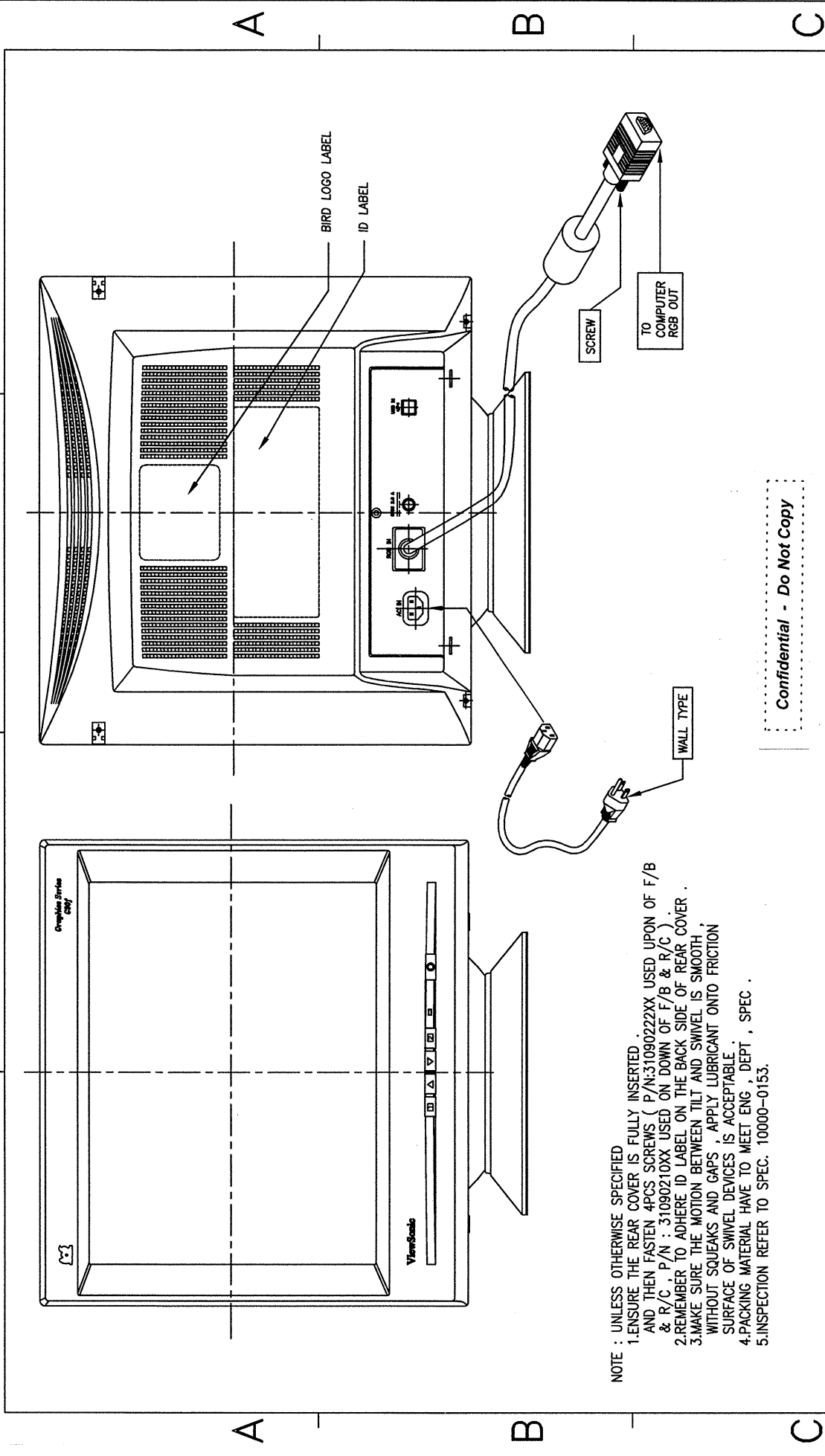

NOTE : UNLESS OTHERWISE SPECIFIED  
 1.ENSURE THE REAR COVER IS FULLY INSERTED .  
 AND THEN FASTEN 4PCS SCREWS ( P/N:31090222XX USED UPON OF F/B  
 & R/C , P/N : 31090210XX USED ON DOWN OF F/B & R/C ) .  
 2.REMEMBER TO ADHERE ID LABEL ON THE BACK SIDE OF REAR COVER .  
 3.MAKE SURE THE MOTION BETWEEN TILT AND SWIVEL IS SMOOTH .  
 WITHOUT SQUEAKS AND GAPS , APPLY LUBRICANT ONTO FRICTION  
 SURFACE OF SWIVEL DEVICES IS ACCEPTABLE .  
 4.PACKING MATERIAL HAVE TO MEET ENG , DEPT , SPEC .  
 5.INSPECTION REFER TO SPEC. 10000-0153.

Confidential - Do Not Copy

<b>ViewSonic Corporation</b>		<b>DESCRIPTION:</b> ENGINEERING NOTICES	
THESE DRAWINGS AND SPECIFICATIONS ARE THE PROPERTY OF DELTA ELECTRONICS, INC. AND SHALL NOT BE REPRODUCED OR USED AS THE BASIS FOR THE MANUFACTURE OR SELL OF APPARATUS OR DEVICES WITHOUT PERMISSION.		THIRD ANGLE PROJECTION	DRAWING NO.: 336M2095
DIMENSIONAL TOLERANCES		SIZE	SHEET 2 TO 3
UN-100 : ±0.2	UN-100 : ±0.2	A4	REV. 00
<30 : ±0.25	100-150 : ±0.25		
>30-100 : ±0.3	150-200 : ±0.3		
>100-300 : ±0.5	200-300 : ±0.36		
APPROX 300 : ±0.6	300-350 : ±0.45		
APPROX 300 : ±0.6	350-400 : ±0.45		
HOLES: ±0.05	ANGLES:±0.5°		
SCALE: 1/1	UNIT: MM	USED ON: DE-995 SC 01	
Drawn: 唐敏秀 05/16/00		Approved: 唐明德 05/16/00	
Designed: 謝坤儒 05/16/00			
Checked: 江政道 05/16/00			

FRAME NAME : PR5-5R00.DWG 1 2 3 4



4

3

2

1

A

B

C

SIGNAL CABLE & WIRE WITH TERMINAL FIXED WITH A SCREW TAPPING 4x18x8 P/N:31090204XX

TO V/B SHIELD CAN P/N:36400273XX

FIXED WITH SCREW TAPPING M3\*0.5\*8(P/N:31090101XX)

WIRE WITH TERMINAL (P/N:36400273XX) FIXED WITH A SCREW TAPPING 4x18x8 P/N:31090204XX

SERIAL LABEL

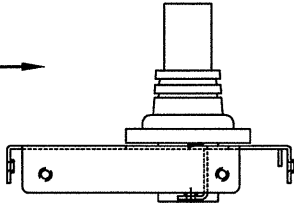
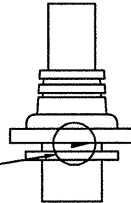

NOTE : UNLESS OTHERWISE SPECIFIED

1.SIGNAL CABLE 安裝於 REAR BRACKET 時其 S/R 之倒勾須向上並卡在 REAR BRACKET 之兩個圓孔內

2.SIGNAL CABLE (P/N:30803028XX L=1.8m IVORY) AND WIRE WITH TERMINAL (P/N:36400273XX) USE SCREW TAPPING P/N:31090204XX TO FIX ON HOLE OF REAR BRACKET (AS UP PICTURE)

3.MAIN BOARD SERIAL LABEL (P/N:32001284XX)

Confidential - Do Not Copy

ViewSonic Corporation		DRAWING NO.: 336M2095		REVISION: 00	
THESE DRAWINGS AND SPECIFICATIONS ARE THE PROPERTY OF DELTA ELECTRONICS, INC. AND SHALL NOT BE REPRODUCED OR USED AS THE BASIS FOR THE MANUFACTURE OR SELL OF APPARATUS OR DEVICES WITHOUT PERMISSION.		DESCRIPTION: ENGINEERING NOTICES		SHEET 5 TO 6	
DIMENSIONAL TOLERANCES		THIRD ANGLE PROJECTION		SIZE A4	
( ) : ±0.25	( ) : ±0.2	DRAWN: 詹敏秀 05/16/00		APPROVED: 詹明德 05/16/00	
>30-100 : ±0.25	100-150 : ±0.25	DESIGNED: 謝坤儒 05/16/00		CHECKED: 江政道 05/16/00	
100-200 : ±0.3	150-200 : ±0.3	USED ON: DE-995 SC 01		DRAWING NO.: 336M2095	
200-300 : ±0.5	200-250 : ±0.35	SCALE: 1/1		REV. 00	
300-400 : ±0.5	300-350 : ±0.45	UNIT: MM		SHEET 5 TO 6	
HOLES: ±0.06	350-400 : ±0.5	ANGLER: ±0.5°		FRAME NAME: FR5-5R00.DWG	

4

3

2

1

1      2      3      4

MAIN BOARD ASS'Y

WIRE WITH TERMINAL  
P/N: 36423137XX(BLACK)

WIRE WITH TERMINAL  
P/N: 36406501XX(BLUE)

WIRE WITH TERMINAL  
P/N: 36406502XX(BLACK)

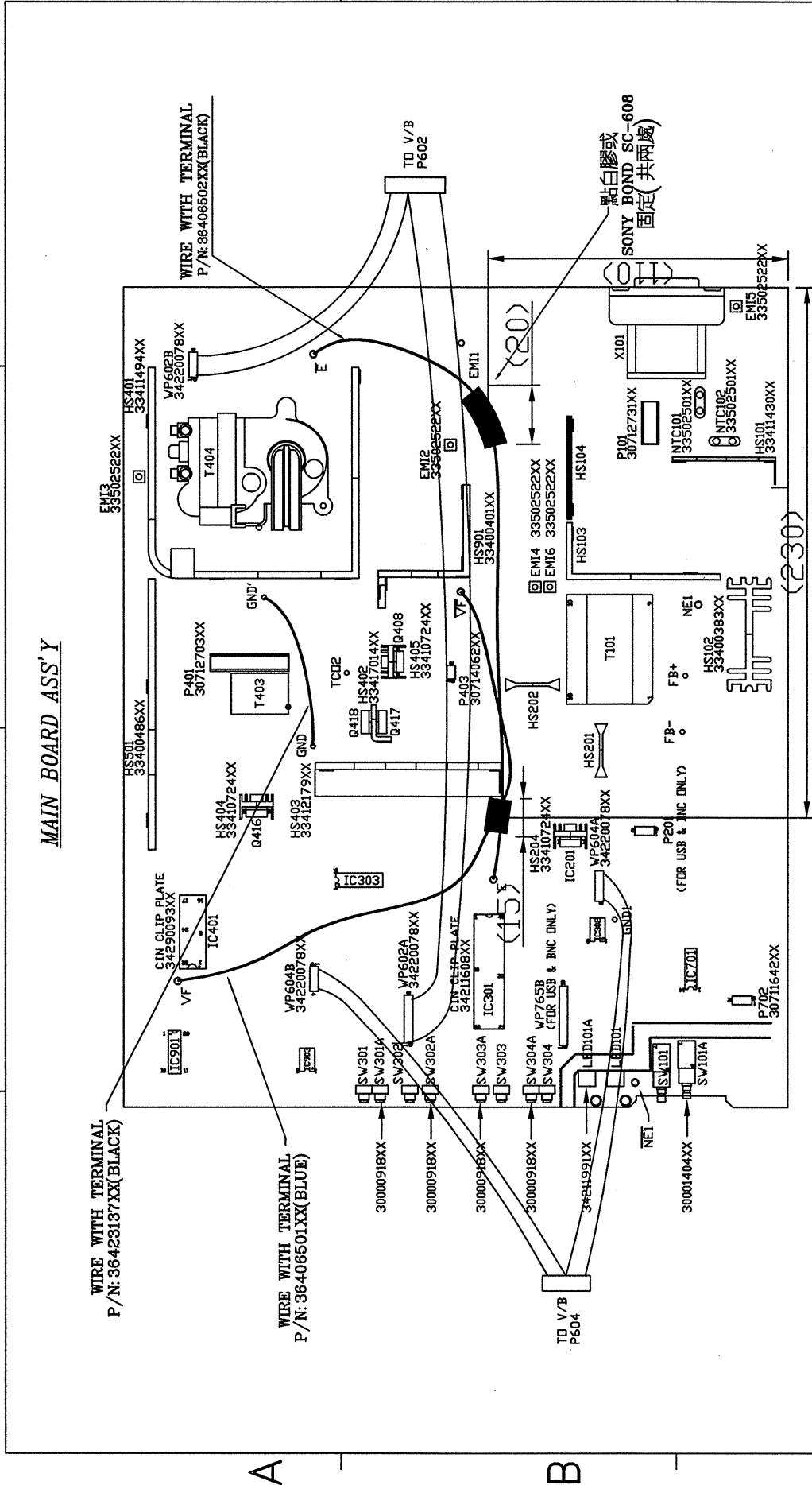

Confidential - Do Not Copy

<b>ViewSonic Corporation</b>		<b>DESCRIPTION:</b> ENGINEERING NOTES	
THESE DRAWINGS AND SPECIFICATIONS ARE THE PROPERTY OF DELTA ELECTRONICS, INC. AND SHALL NOT BE REPRODUCED OR USED AS THE BASIS FOR THE MANUFACTURE OR SALE OF APPARATUS OR DEVICES WITHOUT PERMISSION.		THIRD ANGLE PROJECTION	SIZE
DRAWN: 唐敏秀 05/16/00		DRAWING NO.: 336M2095	
DESIGNED: 江斌 05/16/00		SHEET 6 TO 7	
CHECKED: 戴勝義 05/16/00		REV. 00	
APPROVED: 王文彬 05/16/00			

FRAME NAME : FR5-5R00.DWG      1      2      3      4

4

3

2

1

- NOTE : UNLESS OTHERWISE SPECIFIED  
1.MAIN BOARD 零件標打圖釘之位置如下:  
(a) TRANSFORMER T101 之 PIN 1,9,14 共三顆  
    (P/N:33501411XX)  
(b) FBT T404 之 PIN 1,2,5,8,10 共五顆  
    (P/N:33501419XX)  
(c) CAPACITOR C101 2PINS 共兩顆  
    (P/N:33501411XX)
- 2.AC SOCKET 裝置在 MAIN BOARD X101. 其定位孔應與 MAIN BOARD 之定位孔對齊,以利除塵動作,不影響 2顆 SCREW (M3x0.5x10 P/N:31090103XX) 之上裝
- 3.REAR BRACKET 裝置在 MAIN BOARD 之後方,其孔位須修正 MAIN BD 之孔加鑽螺絲,其中 2顆 (3x0.5x10 P/N:31090103XX) 會一併將 AC SOCKET & MAIN BD 鎖上;另二顆 (3x0.5x8 P/N:31090101XX) 直接由 MAIN BD 鎖至 REAR BRACKET.
- 4.WHEN INSERTING THE HS401 & HS501 REMEMBER TO FIX THEM TOGETHER WITH SCREW P/N:31003010XX AT FIRST AND THEN TO TWIST THE HS401 & HS501 6 PCS DEEP PIN ON THE SOLDER SIDE OF PCB BEFORE WAVE SOLDERING.

MOUNTING 5 RIVETS  
ON FBT T404. PIN: 1, 2, 5, 8, 10.

MOUNTING 3 RIVETS  
ON TRANSFORMER T101: PIN 1, 9, 14.

MOUNTING 2 RIVETS  
ON CAPACITOR C101.

TO INSERT 3 PCS SPACER SUPPORT P/N:34210479XX ON THE SOLDER SIDE OF M/B, THEN ADHESIVE THEM WITH WHITE GLUE

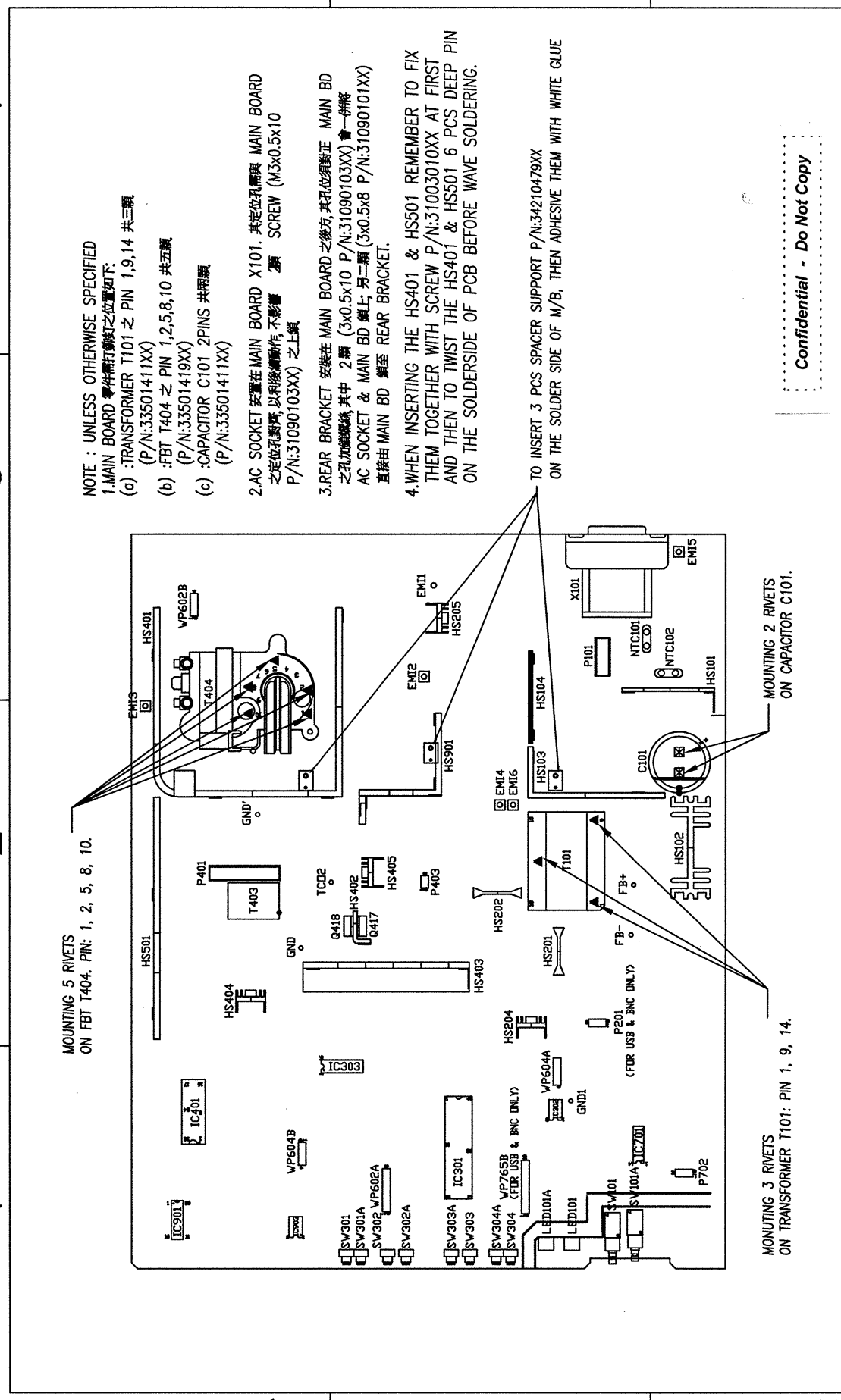

Confidential - Do Not Copy

Drawn: 詹敏秀 05/16/00		THIRD ANGLE PROJECTION	DESCRIPTION: ENGINEERING NOTECES	
Designed: 江政道 05/16/00			DRAWING NO.: 336M2095	
Checked: 戴勝義 05/16/00		SIZE: A4	REV. 00	
Approved: 王文彬 05/16/00			SHEET 7 TO 8	

DIMENSIONAL TOLERANCES			
( )	( )	( )	( )
UP-100 : ±0.2	UP-600 : ±1.5	UP-100 : ±0.2	UP-600 : ±1.5
100-150 : ±0.25	600-900 : ±2.4	100-150 : ±0.25	600-900 : ±2.4
150-200 : ±0.3	900-999 : ±3.1	150-200 : ±0.3	900-999 : ±3.1
>100-200 : ±0.5		>100-200 : ±0.5	
200-300 : ±0.6		200-300 : ±0.6	
300-350 : ±0.6		300-350 : ±0.6	
350-400 : ±0.6		350-400 : ±0.6	
Holes: ±0.06		Holes: ±0.06	
SCALE	UNIT	MM	USED ON DE-995 SC 01

ViewSonic Corporation

THESE DRAWINGS AND SPECIFICATIONS ARE THE PROPERTY OF DELTA ELECTRONICS, INC. AND SHALL NOT BE REPRODUCED OR USED AS THE BASIS FOR THE MANUFACTURE OR SELL OF APPARUSES OR DEVICES WITHOUT PERMISSION.

C

3

2

1

4

3

2

1

4

3

2

1

### VIDEO BOARD ASS'Y

NOTE : UNLESS OTHERWISE SPECIFIED

1.VIDEO BOARD 零件需打铆钉之位置如下:

(a) :CRT SOCKET 之 PIN 5,9,12 共三颗  
(P/N:33501419XX)

MOUNTING 3 RIVETS  
ON CRT SOCKET. PIN: 5,9,12

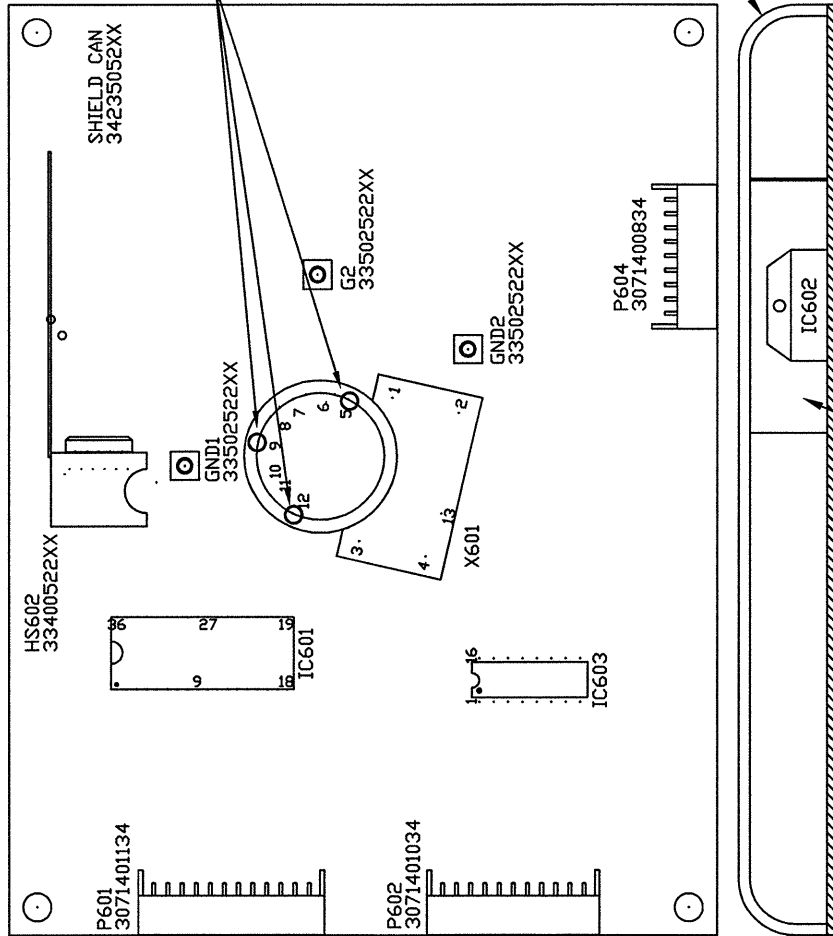

Confidential - Do Not Copy

ViewSonic Corporation <small>THESE DRAWINGS AND SPECIFICATIONS ARE THE PROPERTY OF DELTA ELECTRONICS, INC. AND SHALL NOT BE REPRODUCED OR USED AS THE BASIS FOR THE MANUFACTURE OR SELL OF APPARATUS OR DEVICES WITHOUT PERMISSION.</small>	DRAWING NO.: 336M2095		REV. 00
	SHEET 8 TO 9		00
DESCRIPTION: ENGINEERING NOTICES		DRAWING NO.: 336M2095	
THIRD ANGLE PROJECTION		SIZE A4	
Drawn: 唐敏秀 05/16/00	Designed: 謝坤儒 05/16/00	Checked: 戴勝義 05/16/00	
Approved: 王文彬 05/16/00		SC 01	
DIMENSIONAL TOLERANCES		UNIT MM	
SCALE 1/1		USED ON DE-995	

4

3

2

1

FRAME NAME : FR5-5R00.DWG

1 2 3 4

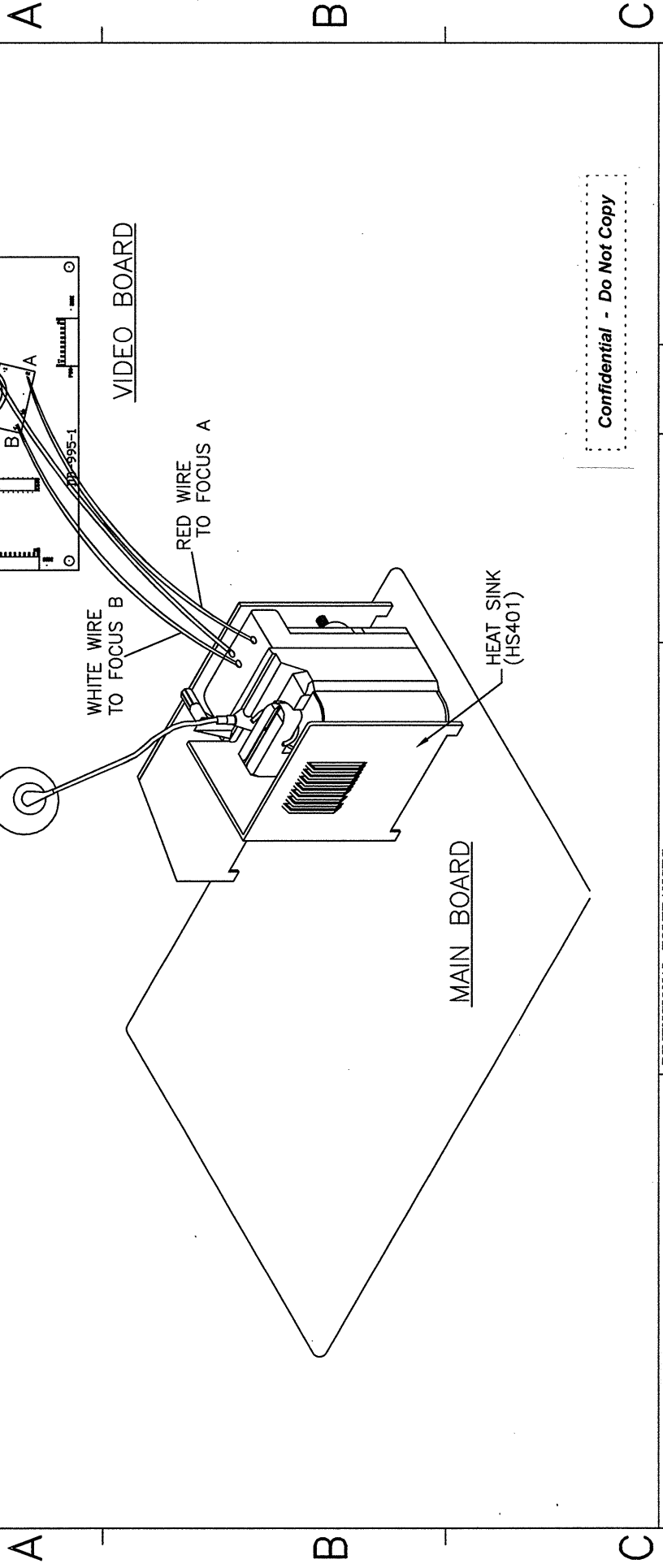

Confidential - Do Not Copy

<b>ViewSonic Corporation</b>		<b>DEPARTMENT OF MANUFACTURING</b>		<b>DESCRIPTION:</b>	
<small>THESE DRAWINGS AND SPECIFICATIONS ARE THE PROPERTY OF DELTA ELECTRONICS, INC. AND SHALL NOT BE REPRODUCED OR USED AS THE BASIS FOR THE MANUFACTURE OR SELL OF APPARATUS OR DEVICES WITHOUT PERMISSION.</small>		<small>DIMENSIONAL TOLERANCES</small> ( ) : ±0.25 <30 : ±0.15 >30-100 : ±0.25 >100-200 : ±0.3 >200-300 : ±0.4 >300-500 : ±0.5 HOLES: ±0.06		<small>THIRD ANGLE PROJECTION</small> <b>A4</b>	
<small>SCALE</small> 1:1 <small>UNIT</small> MM <small>USED ON</small> DE-995 SC 01		<small>Drawn:</small> 唐敏秀 05/16/00 <small>Designed:</small> 謝坤儒 05/16/00 <small>Checked:</small> 戴勝義 05/16/00 <small>Approved:</small> 王文彬 05/16/00		<b>ENGINEERING NOTES</b> <small>DRAWING NO.:</small> 336M2095 <small>SHEET</small> 9 TO 10	
				<small>REV.</small> 00	

1 2 3 4

1 2 3 4

**20' CONTAINER'S PACKING  
FOR 19" MONITOR**  
 PALLET (P/N : 35200174XX=C6)  
 PALLET (P/N : 35200182XX)  
 PAPER ANGLE (P/N : 35103892XX)  
 CAPACITY ARE 144 UNITS (WITH PALLET)

PALLET P/N: 35200182XX  
 PALLET P/N: 35200174XX

Put 2 parcels of dryers  
 above cargo per pallet

CARTON OUTLINE DIM:  
 568(W)X588(L)X524(H)

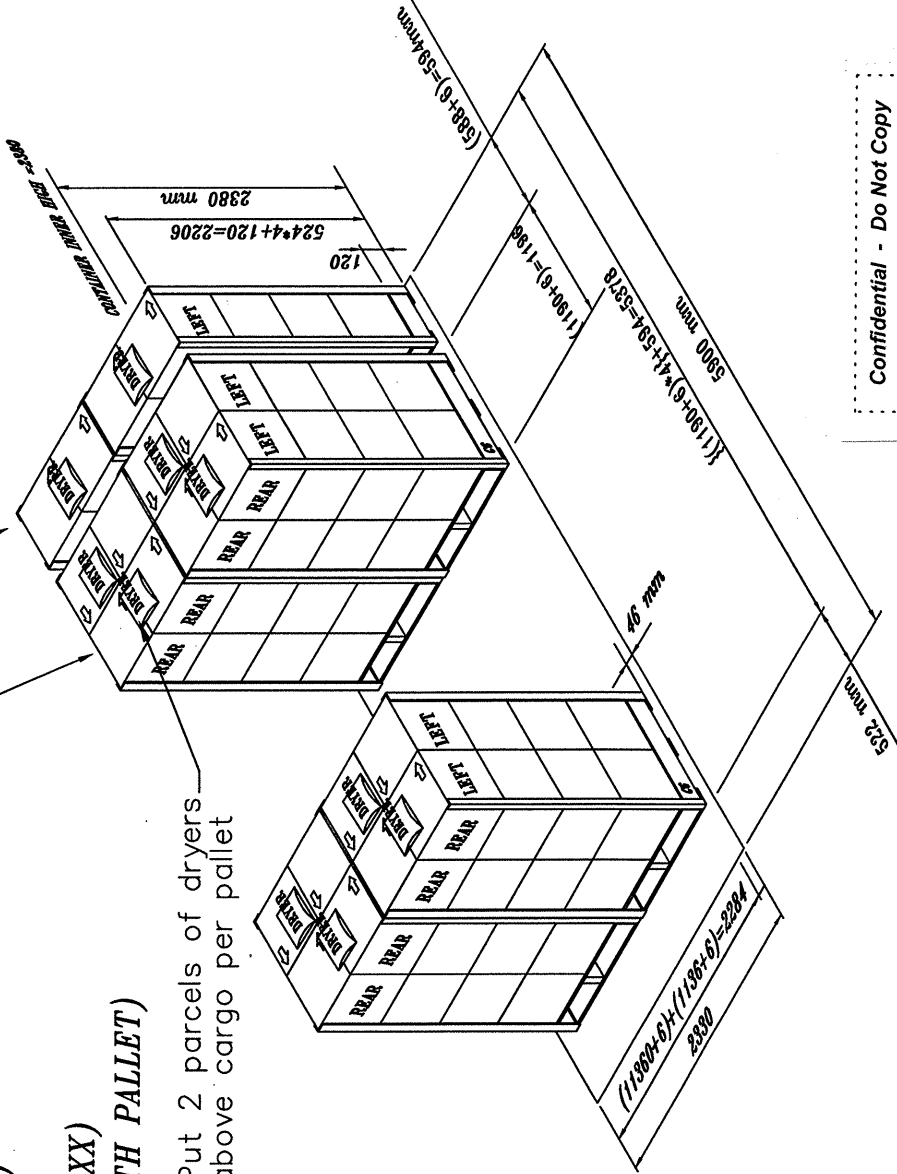
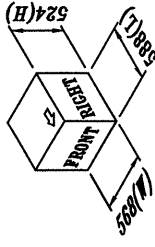

Confidential - Do Not Copy

ViewSonic Corporation	DESCRIPTION: ENGINEERING NOTICES	
	Drawn: 詹敏秀 05/16/00	THEED ANGLE PROJECTION
DESIGNED: 謝坤儒 05/16/00		DRAWING NO.: 336M2095
CHECKED: 柯金昆 05/16/00		
APPROVED: 唐明德 05/16/00		REV. 00
SCALE: 1/1		SIZE: A4
UNIT: MM		SHEET: 10 TO 11
DIMENSIONAL TOLERANCES		
( ) : ±0.25	UP~100 : ±0.2	
>30-100 : ±0.25	100~150 : ±0.25	
100~200 : ±0.3	150~200 : ±0.3	
200~300 : ±0.35	200~300 : ±0.35	
300~400 : ±0.4	300~400 : ±0.4	
400~500 : ±0.45	350~400 : ±0.5	
HOLE: ±0.06	ANGLES: ±0.5°	
SCALE: 1/1	UNIT: MM	USED ON: DE-995 SC 01
THESE DRAWINGS AND SPECIFICATIONS ARE THE PROPERTY OF DELTA ELECTRONICS, INC. AND SHALL NOT BE REPRODUCED OR USED AS THE BASIS FOR THE MANUFACTURE OR SELL OF APPARATUS OR DEVICES WITHOUT PERMISSION.		

FRAME NAME : FR5-5R00.DWG 1 2 3 4

1 2 3 4

40' CONTAINER'S PACKING  
 FOR 19" MONITOR  
 PALLET (P/N : 35200174XX=C6)  
 PAPER ANGLE (P/N : 35103892XX)  
 CAPACITY ARE 320 UNITS (WITH PALLET)

PALLET P/N: 35200174XX

Put 2 parcels of dryers  
 above cargo per pallet

CARTON OUTLINE DIM:  
 568(W)x588(L)x524(H)

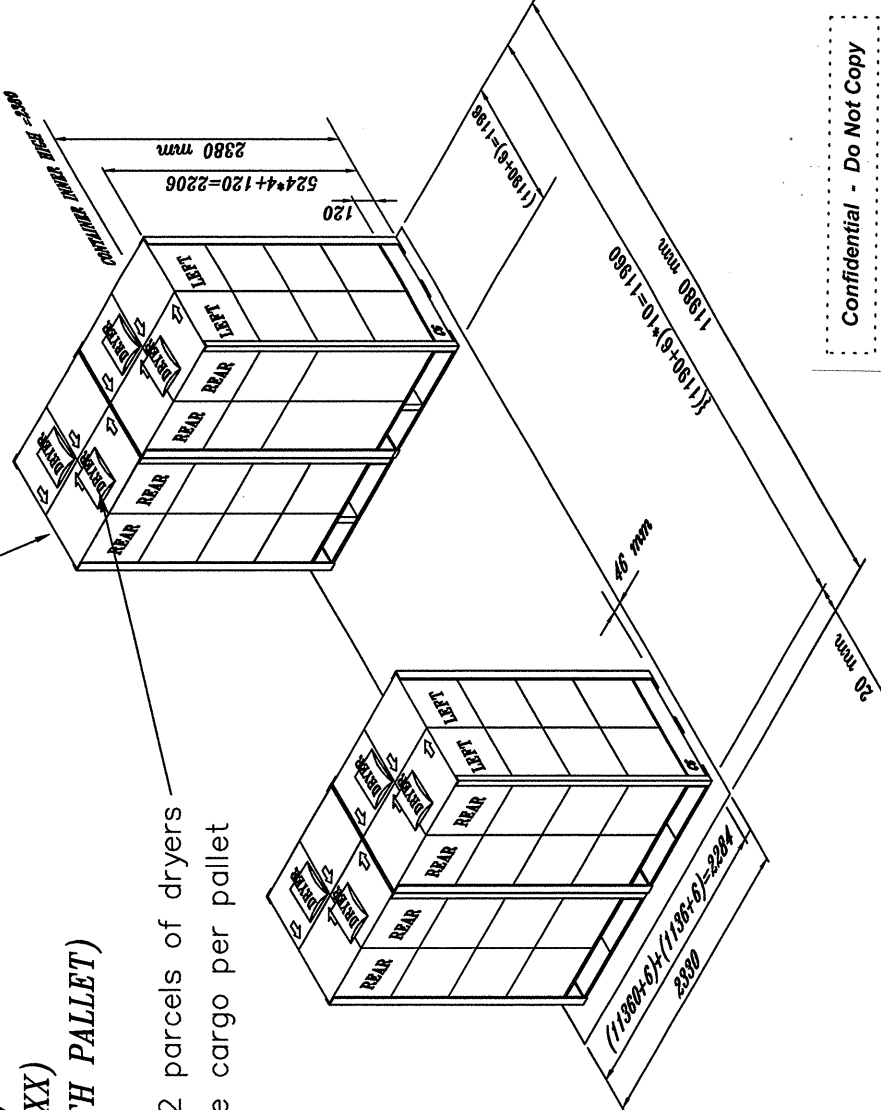
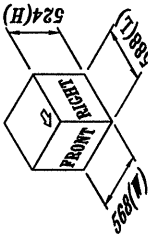

Confidential - Do Not Copy

ViewSonic Corporation	DIMENSIONAL TOLERANCES		DRAWN: 唐敏秀 05/1600		DESCRIPTION: ENGINEERING NOTECES	
	SCALE	UNIT	MM	USED ON	DE-995	SC 01
THESE DRAWINGS AND SPECIFICATIONS ARE THE PROPERTY OF DELTA ELECTRONICS, INC. AND SHALL NOT BE REPRODUCED OR USED AS THE BASIS FOR THE MANUFACTURE OR SELL OF APPARATUS OR DEVICES WITHOUT PERMISSION.		UP-100 : ±0.2		UP-600 : ±1.5		DRAWING NO.: 336M2095
		100-150 : ±0.25		600-900 : ±2.4		
		150-200 : ±0.3		900-995 : ±3.1		REV. 00
		200-300 : ±0.35				
		300-400 : ±0.4				
		400-500 : ±0.45				
		500-600 : ±0.5				
		Holes: ±0.05		ANGLES: ±0.5°		
		DETAILS		THIRD ANGLE PROJECTION		
		T : ±0.3		SIZE A4		
		R : ±0.2				
		X : ±0.2				
		Y : ±0.2				
		Z : ±0.2				
		X1 : ±0.1				
		X2 : ±0.1				
		X3 : ±0.1				
		X4 : ±0.1				
		X5 : ±0.1				
		X6 : ±0.1				
		X7 : ±0.1				
		X8 : ±0.1				
		X9 : ±0.1				
		X10 : ±0.1				
		X11 : ±0.1				
		X12 : ±0.1				
		X13 : ±0.1				
		X14 : ±0.1				
		X15 : ±0.1				
		X16 : ±0.1				
		X17 : ±0.1				
		X18 : ±0.1				
		X19 : ±0.1				
		X20 : ±0.1				
		X21 : ±0.1				
		X22 : ±0.1				
		X23 : ±0.1				
		X24 : ±0.1				
		X25 : ±0.1				
		X26 : ±0.1				
		X27 : ±0.1				
		X28 : ±0.1				
		X29 : ±0.1				
		X30 : ±0.1				
		X31 : ±0.1				
		X32 : ±0.1				
		X33 : ±0.1				
		X34 : ±0.1				
		X35 : ±0.1				
		X36 : ±0.1				
		X37 : ±0.1				
		X38 : ±0.1				
		X39 : ±0.1				
		X40 : ±0.1				
		X41 : ±0.1				
		X42 : ±0.1				
		X43 : ±0.1				
		X44 : ±0.1				
		X45 : ±0.1				
		X46 : ±0.1				
		X47 : ±0.1				
		X48 : ±0.1				
		X49 : ±0.1				
		X50 : ±0.1				
		X51 : ±0.1				
		X52 : ±0.1				
		X53 : ±0.1				
		X54 : ±0.1				
		X55 : ±0.1				
		X56 : ±0.1				
		X57 : ±0.1				
		X58 : ±0.1				
		X59 : ±0.1				
		X60 : ±0.1				
		X61 : ±0.1				
		X62 : ±0.1				
		X63 : ±0.1				
		X64 : ±0.1				
		X65 : ±0.1				
		X66 : ±0.1				
		X67 : ±0.1				
		X68 : ±0.1				
		X69 : ±0.1				
		X70 : ±0.1				
		X71 : ±0.1				
		X72 : ±0.1				
		X73 : ±0.1				
		X74 : ±0.1				
		X75 : ±0.1				
		X76 : ±0.1				
		X77 : ±0.1				
		X78 : ±0.1				
		X79 : ±0.1				
		X80 : ±0.1				
		X81 : ±0.1				
		X82 : ±0.1				
		X83 : ±0.1				
		X84 : ±0.1				
		X85 : ±0.1				
		X86 : ±0.1				
		X87 : ±0.1				
		X88 : ±0.1				
		X89 : ±0.1				
		X90 : ±0.1				
		X91 : ±0.1				
		X92 : ±0.1				
		X93 : ±0.1				
		X94 : ±0.1				
		X95 : ±0.1				
		X96 : ±0.1				
		X97 : ±0.1				
		X98 : ±0.1				
		X99 : ±0.1				
		X100 : ±0.1				

FRAME NAME : FR5-5R00 DWG 1 2 3 4

4

3

2

1

CRT GROUNDING WIRE ASS'Y  
EMI SOLUTION

1. DEGAUSSING COIL之CONNECTOR WIRE 將 CONNECTOR 插入 MAIN BOARD 之 P101 如左圖所示。
2. DEGAUSSING COIL 裝置於 CRT 上，需先用二條 CABLE TIE P/N:34210325XX 固定 CRT 之上端左右二角後暫不拉緊，再用二條 CABLE TIE P/N:34210325XX 固定下端之左右二角拉緊固定之，再拉緊上端左右兩端 CABLE TIE 避免 DEGAUSSING COIL 造成前殼上端兩 BOSS 變形。組裝後注意 DEGAUSSING COIL 固定於 CRT 時其上端須遠離 CRT 之高壓區的紅色限制區(如左圖所示)

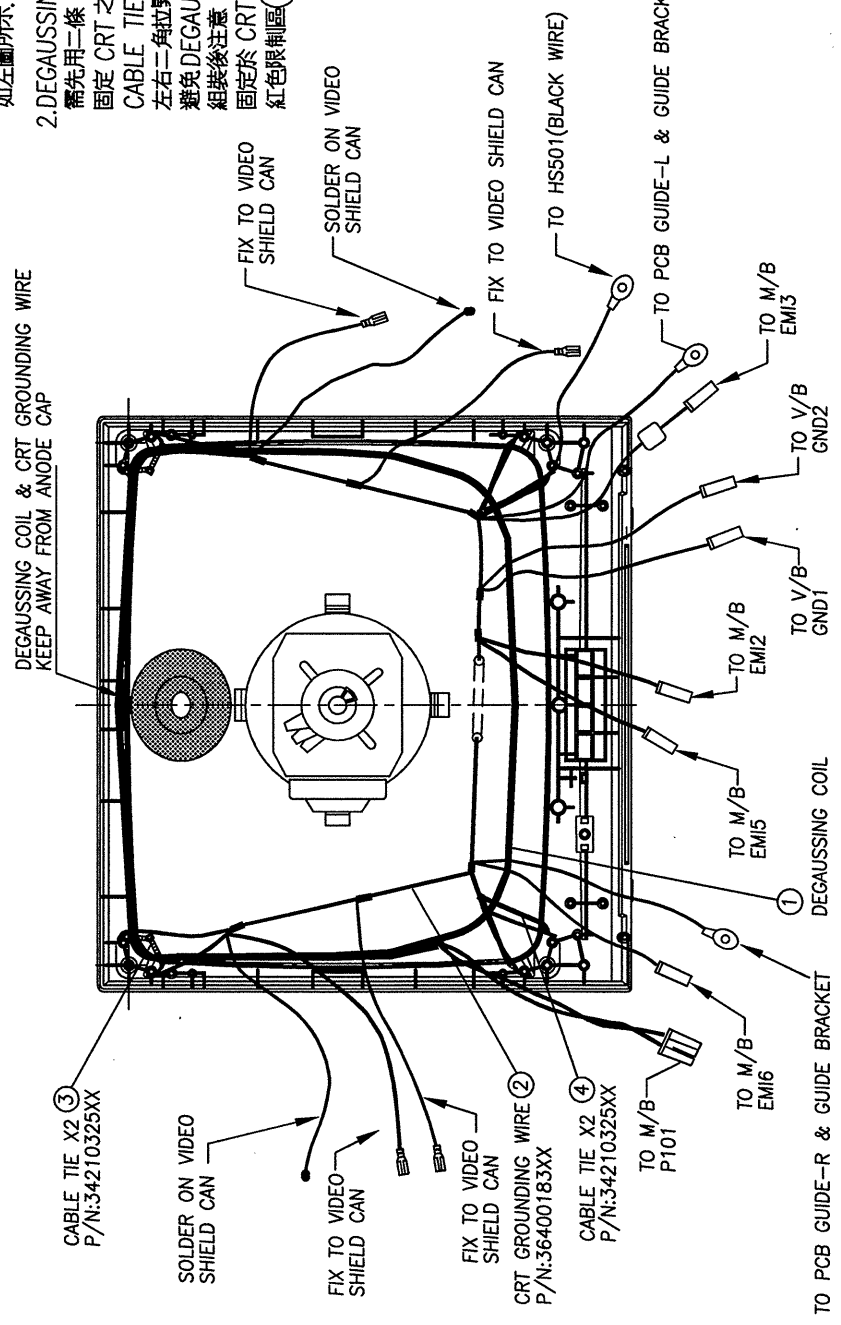

Confidential - Do Not Copy

ViewSonic Corporation		Drawn: 詹敏秀 05/17/00		THIRD ANGLE PROJECTION		DESCRIPTION: ENGINEERING NOTICES	
<small>THESE DRAWINGS AND SPECIFICATIONS ARE THE PROPERTY OF DELTA ELECTRONICS, INC. AND SHALL NOT BE REPRODUCED OR USED AS THE BASIS FOR THE MANUFACTURE OR SELL OF APPARATUS OR DEVICES WITHOUT PERMISSION.</small>		Designed: 傅裕元 05/17/00		A4		DRAWING NO.: 336M2095	
<small>DIMENSIONAL TOLERANCES</small> ( ) ( ) ( ) ( ) UP-100 : ±0.2    UP-600 : ±1.5 100-150 : ±0.25    600-900 : ±2.4 150-200 : ±0.3    900-999 : ±3.1 200-250 : ±0.36 250-300 : ±0.4 300-350 : ±0.45 350-400 : ±0.5 HOLE: ±0.06    ANGLES: ±0.5°		Checked: 戴勝義 05/17/00		SIZE		REV. 00	
SCALE: 1/1		UNIT: MM		USED ON: DE-995 SC 01		SHEET 12 TO 13	
		Approved: 王文彬 05/17/00					

4

3

2

1



1 2 3 4

CRT GROUNDING WIRE & VIDEO SHIELD CAN ASS'Y RIGHT SIDE  
EMI SOLUTION

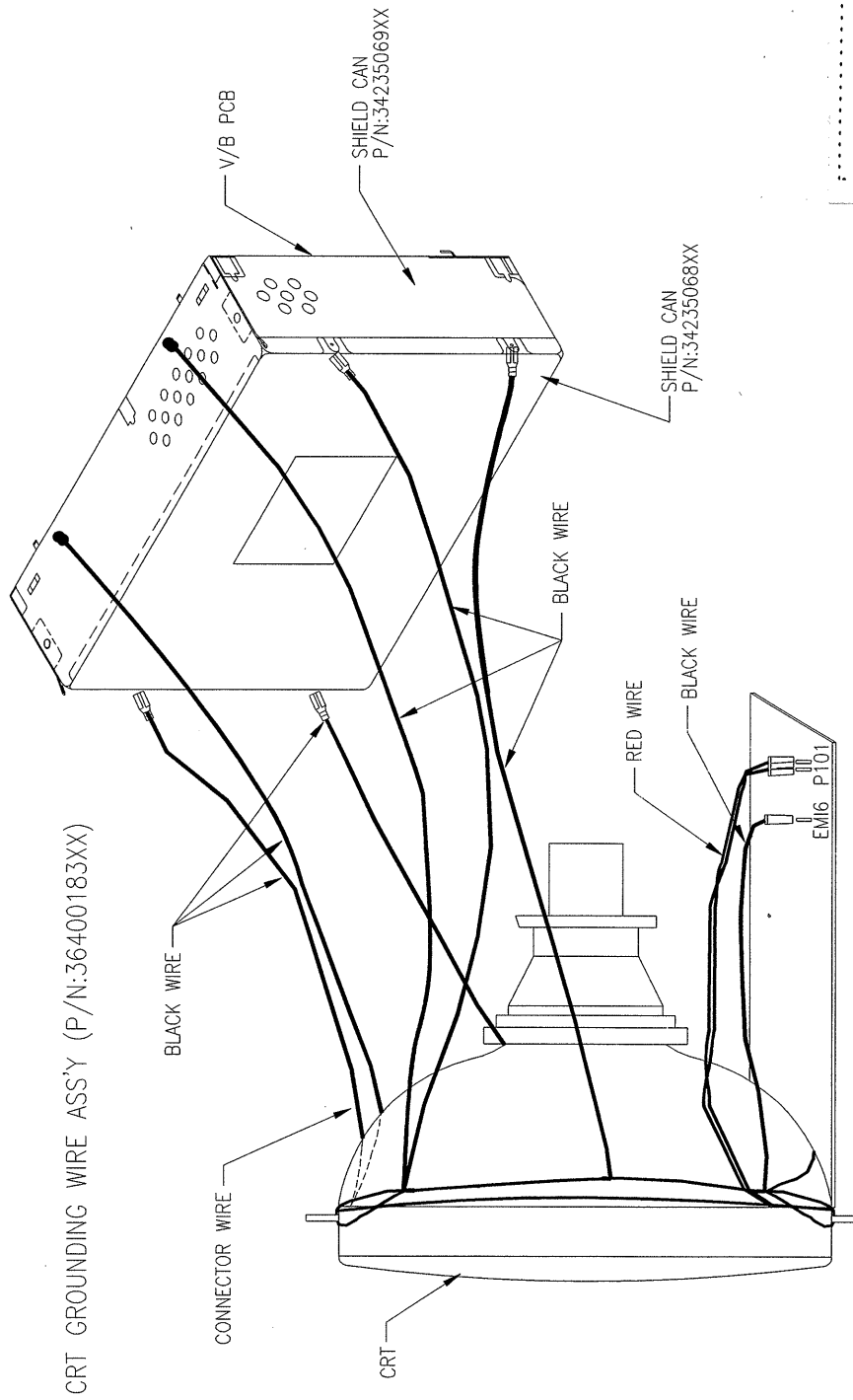

Confidential - Do Not Copy

ViewSonic Corporation		DE-995 SC 01	
<p>THESE DRAWINGS AND SPECIFICATIONS ARE THE PROPERTY OF DELTA ELECTRONICS, INC. AND SHALL NOT BE REPRODUCED OR USED AS THE BASIS FOR THE MANUFACTURE OR SELL OF APPARATUS OR DEVICES WITHOUT PERMISSION.</p>		<p>SCALE: UNIT: MM USED ON: DE-995 SC 01</p>	
<p>DIMENSIONAL TOLERANCES</p> <p>( ) UP~100 : ±0.2 100~150 : ±0.25 150~200 : ±0.3 200~250 : ±0.35 250~300 : ±0.4 300~350 : ±0.45 350~400 : ±0.5</p> <p>( ) UP~600 : ±1.5 600~900 : ±2.4 900~OVER : ±3.1</p> <p>( ) DECIMALS V : ±0.3 X : ±0.2 XX : ±0.1 ANGLES: ±0.5°</p>		<p>Drawn: 詹敏秀 05/18/00 Designed: 傅裕元 05/18/00 Checked: 戴勝義 05/18/00 Approved: 王文彬 05/18/00</p>	
<p>DESCRIPTION: ENGINEERING NOTICES</p>		<p>THIRD ANGLE PROJECTION</p>	
<p>DRAWING NO.: 336M2095</p>		<p>SIZE: A4</p>	
<p>REV. 00</p>		<p>SHEET 13 TO 14</p>	

FRAME NAME : PF5-5R00.DWG 1 2 3 4

1 2 3 4

EMI SOLUTION

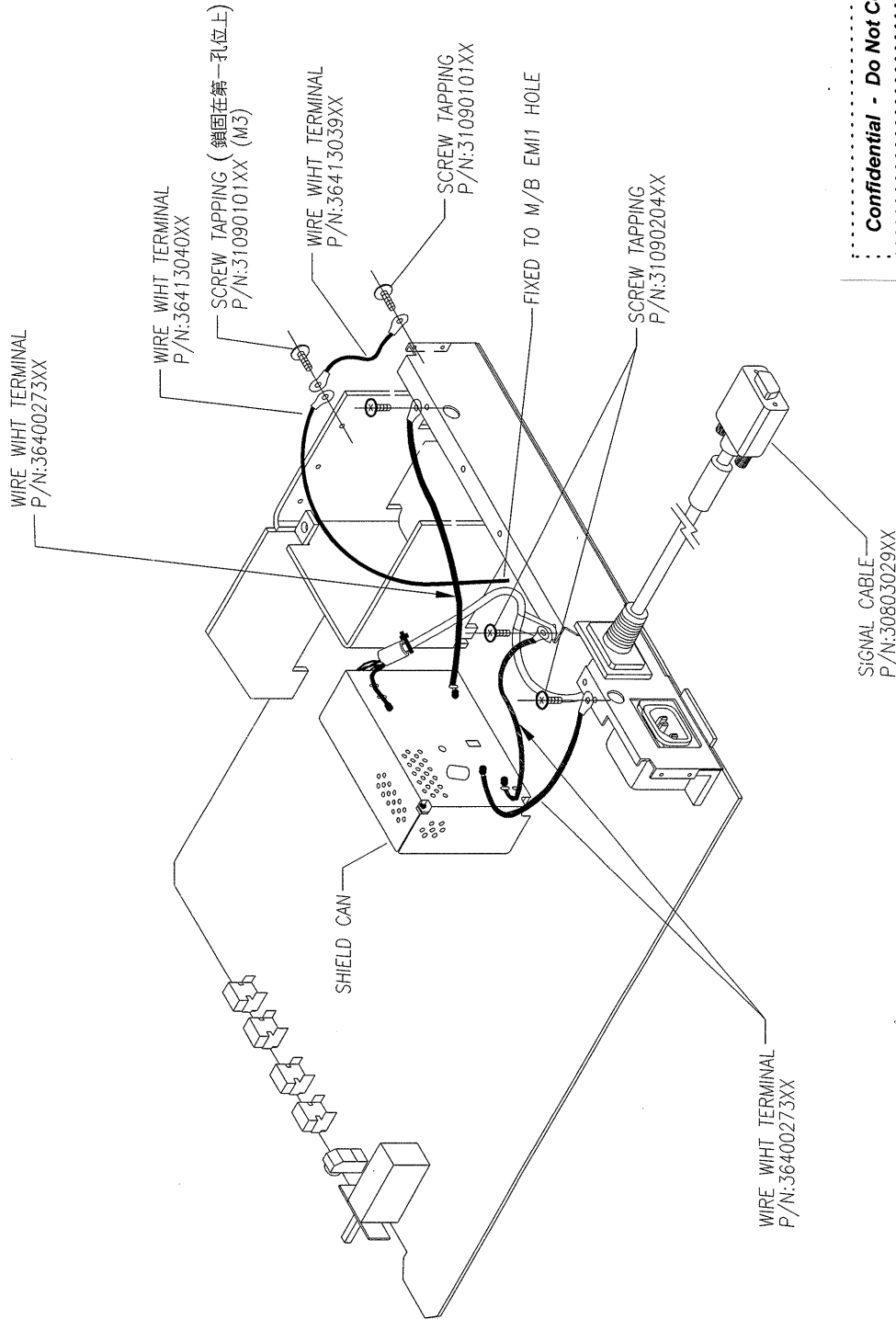

Confidential - Do Not Copy

Drawn: 詹敏秀 05/16/00	THIRD ANGLE PROJECTION	DESCRIPTION: ENGINEERING NOTECES
Designed: 謝坤儒 05/16/00	A4	DRAWING NO.: 336M2095
Checked: 戴勝義 05/16/00	SIZE	SHEET 14 TO 15
Approved: 王文彬 05/16/00		REV. 00

DIMENSIONAL TOLERANCES ( )		UP~600 : ±1.5
<30	: ±0.25	600~900 : ±2.4
>30~100	: ±0.35	900-OVER : ±3.1
>100~300	: ±0.5	
ABOVE 300	: ±0.6	
HOLES: ±0.05		
DECIMALS	X : ±0.3	
	XI : ±0.2	
	XX : ±0.1	
	ANGLES: ±0.5°	
SCALE	UNIT	MM
	USED ON	DE-995 SC 01

**ViewSonic Corporation**

THESE DRAWINGS AND SPECIFICATIONS ARE THE PROPERTY OF DELTA ELECTRONICS, INC. AND SHALL NOT BE REPRODUCED OR USED AS THE BASIS FOR THE MANUFACTURE OR SELL OF APPARATUS OR DEVICES WITHOUT PERMISSION.

1

2

3

4

SCREW TORQUE LIST

ASSEMBLY PARTS	SCREW		TORQUE Kgf.CM	REMARK
	DESCRIPTION	PART NO.		
FRONT BEZEL + REAR COVER	TAPPING SCREW 4x20x16 mm	31090210XX	10 ~ 18	
FRONT BEZEL + REAR COVER	TAPPING SCREW 4x20x35 mm	31090222XX	10 ~ 18	
CRT + FRONT BEZEL	TAPPING SCREW 5x16x25 mm	31090302XX	22 ~ 24	
HS501 + HS401	SCREW MACHINE M3x0.5x10 mm	31003010XX	5 ~ 10	
FRONT BEZEL + PCB GUIDE	SCREW TAPPING 4x20x16 mm	31090210XX	10 ~ 15	
GUIDE BRACKET + PCB GUIDE	SCREW MACHINE M3x0.5x12 mm	31050310XX	5 ~ 10	
CRT GROUNDING WIRE + HS501	SCREW MACHINE M3x0.5x10 mm	31003010XX	5 ~ 10	
WIRE WITH TERMINAL + HS401	SCREW MACHINE M3x0.5x10 mm	31003010XX	5 ~ 10	
HSET SINK + (IC501,Q904,D410,Q905,CR101,Q415,IC101,Q417,Q418, Q423,Q424,Q420,Q408,Q416,IC201,Q422,Q421,Q412,Q437) 3 ~ 5				
METAL BRACKET + PCB	TAPPING SCREW 3x0.5x8 mm	31090101XX	10 ~ 15	
METAL BRACKET + PCB + AC SOCKET	TAPPING SCREW 3x0.5x10 mm	31090103XX	10 ~ 15	
METAL BRACKET + SIGNAL CABLE + FG CABLE	TAPPING SCREW ø4x8 mm	31090204XX	10 ~ 15	

Confidential - Do Not Copy

Drawn: 唐敏秀 05/16/00	THIRD ANGLE PROJECTION	DESCRIPTION: ENGINEERING NOTES	REV.
Designed: 謝坤儒 05/16/00	A4	DRAWING NO.: 336M2095	00
Checked: 柯金昆 05/16/00	SIZE	SHEET 15 TO 16	
Approved: 唐明德 05/16/00			

DIMENSIONAL TOLERANCES		DE-995 SC 01	
( )	( )	( )	( )
<30	: ±0.25	UP-600	: ±1.5
>30-100	: ±0.35	600-900	: ±2.4
>100-300	: ±0.5	900-995	: ±3.1
ABOVE 300	: ±0.6		
HOLESS.	: ±0.05		
DECIMALS	X : ±0.3		
XX	: ±0.1		
ANGLES: ±0.5°			
UP-100	: ±0.2		
150-200	: ±0.3		
200-250	: ±0.35		
250-300	: ±0.4		
300-350	: ±0.45		
350-400	: ±0.5		

ViewSonic Corporation

THESE DRAWINGS AND SPECIFICATIONS ARE THE PROPERTY OF DELTA ELECTRONICS, INC. AND SHALL NOT BE REPRODUCED OR USED AS THE BASIS FOR THE MANUFACTURE OR SELL OF APPARATUS OR DEVICES WITHOUT PERMISSION.

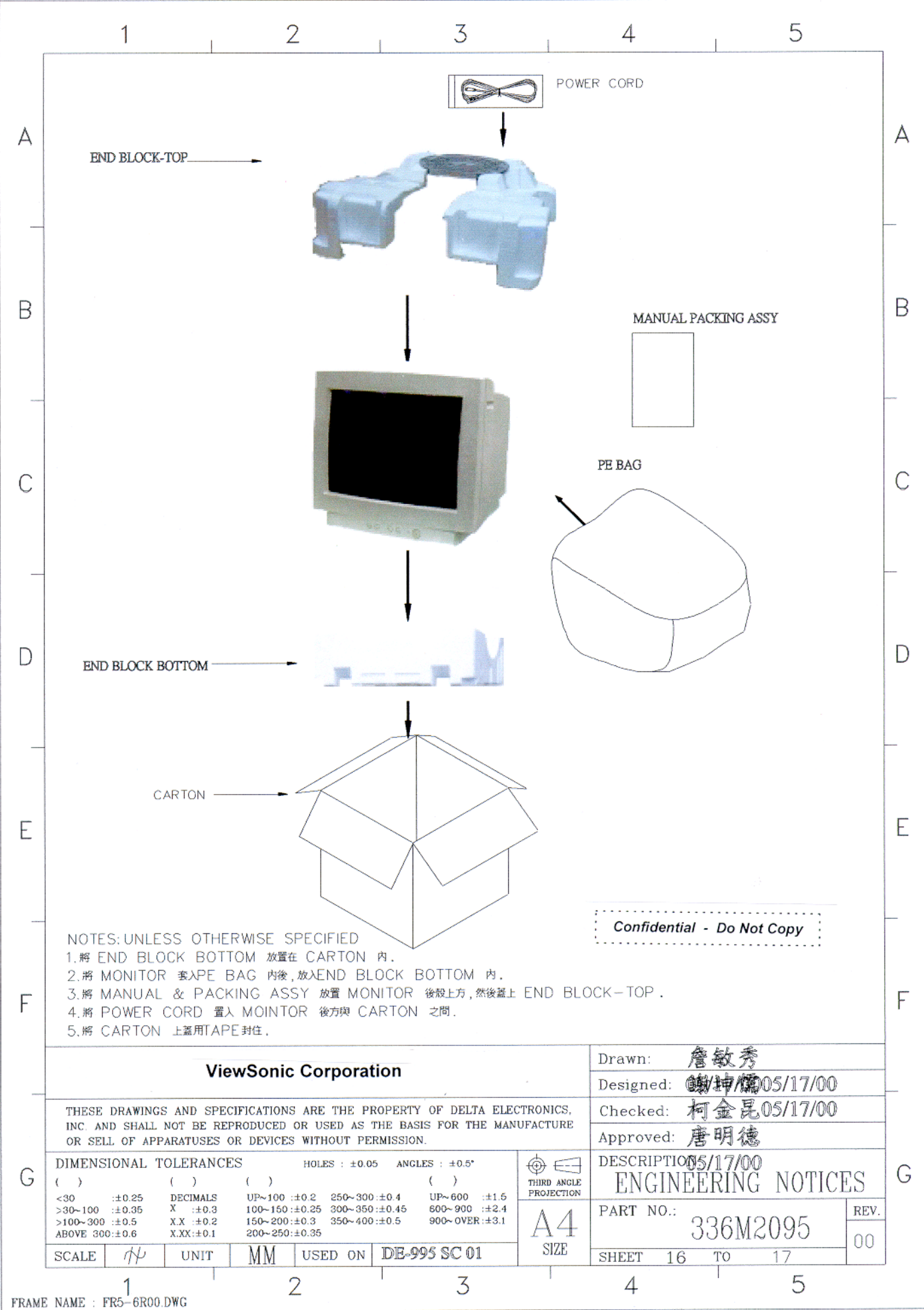

NOTES: UNLESS OTHERWISE SPECIFIED

1. 將 END BLOCK BOTTOM 放置在 CARTON 內。
2. 將 MONITOR 裝入 PE BAG 內後，放入 END BLOCK BOTTOM 內。
3. 將 MANUAL & PACKING ASSY 放置 MONITOR 後殼上方，然後蓋上 END BLOCK-TOP。
4. 將 POWER CORD 置入 MONITOR 後方與 CARTON 之間。
5. 將 CARTON 上蓋用 TAPE 封住。

Confidential - Do Not Copy

<b>ViewSonic Corporation</b>				Drawn: 詹敏秀	
				Designed: 謝坤儒 05/17/00	
THESE DRAWINGS AND SPECIFICATIONS ARE THE PROPERTY OF DELTA ELECTRONICS, INC. AND SHALL NOT BE REPRODUCED OR USED AS THE BASIS FOR THE MANUFACTURE OR SELL OF APPARATUSES OR DEVICES WITHOUT PERMISSION.				Checked: 柯金昆 05/17/00	
				Approved: 唐明德	
DIMENSIONAL TOLERANCES			HOLES : ±0.05	ANGLES : ±0.5°	
( )	( )	( )	THIRD ANGLE PROJECTION		
<30 : ±0.25	DECIMALS	UP~100 : ±0.2	250~300 : ±0.4	UP~600 : ±1.5	
>30~100 : ±0.35	X : ±0.3	100~150 : ±0.25	300~350 : ±0.45	600~900 : ±2.4	
>100~300 : ±0.5	X.X : ±0.2	150~200 : ±0.3	350~400 : ±0.5	900~OVER : ±3.1	
ABOVE 300 : ±0.6	X.XX : ±0.1	200~250 : ±0.35		A4 SIZE	
SCALE	UNIT	MM	USED ON		
			DESCRIPTION		REV.
			ENGINEERING NOTICES		00
			PART NO.: 336M2095		
			SHEET 16 TO 17		

FRAME NAME : FR5-6R00.DWG

1 2 3 4

# TCO SOLUTION

## CANCEL COIL ASS'Y VS CRT SOURCE :

A B C

### NOTE :

1. DY WIRE MADE A CYCLE AND PUT IT UNDER DY BOX
2. POWER CORD NONE SHIELD
3. USE 1PC CABLE TIE TO FIX CANCEL COIL AND GROUNDING WIRE, CANCEL COIL PUT INSIDE FOR GROUNDING WIRE.
4. H.V. CAP DIRECTOR 2 O'CLOCK (ABOUT 60°)

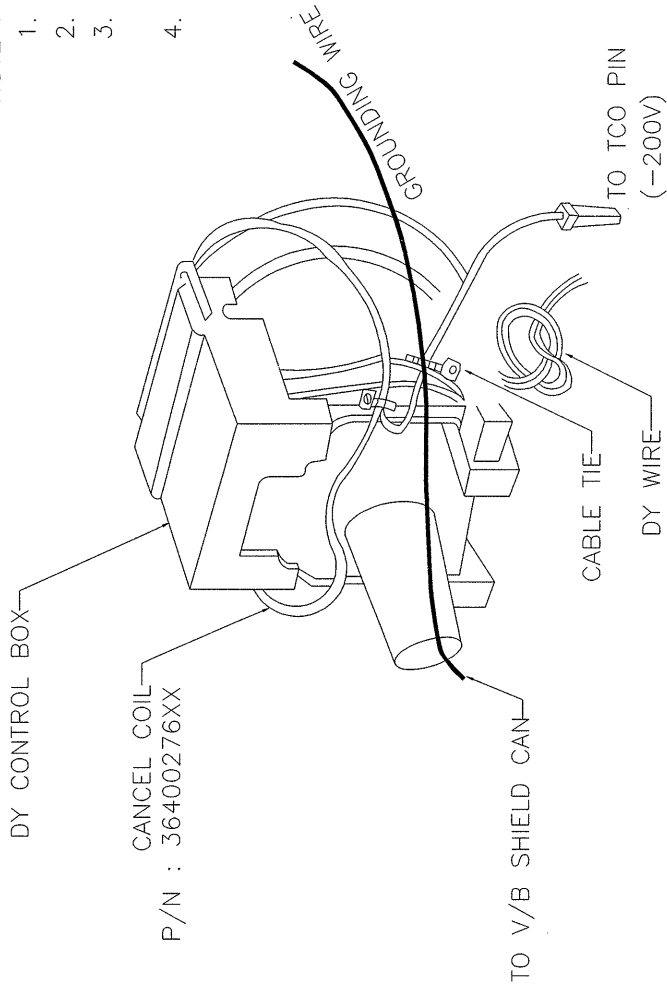

Confidential - Do Not Copy

<b>ViewSonic Corporation</b>		DIMENSIONAL TOLERANCES ( )		DRAWN: 詹敏秀 08/04/00		THIRD ANGLE PROJECTION		DESCRIPTION: ENGINEERING NOTICES	
THESE DRAWINGS AND SPECIFICATIONS ARE THE PROPERTY OF DELTA ELECTRONICS, INC. AND SHALL NOT BE REPRODUCED OR USED AS THE BASIS FOR THE MANUFACTURE OR SELL OF APPARATUS OR DEVICES WITHOUT PERMISSION.		<30	: +0.25	UP~100	: ±0.2	UP~600	: ±1.5	A4	DRAWING NO.: 336M2095
		>30~100	: +0.35	100~150	: ±0.25	600~900	: ±2.4		
		>100~300	: ±0.5	150~200	: ±0.3	900-OVER	: ±3.1		
SCALE ~		UNIT	mm	USED ON	DE-995 SC 01	SIZE		SHEET 17 TO 18	
		HOLES: ±0.05	ANGLES: ±0.5°	300~350	: ±0.45	APPROVED: 王文彬 08/04/00		REV. 00	

1 2 3 4

TCO SOLUTION

CANCEL COIL ASS'Y  
VS CRT SOURCE : HITACHI

A B C

NOTE :

1. USE 3 PCS CABLE TIE TO FIX CANCEL COIL 用螺絲固定在下方鐵架
2. 右側 GROUNDING WIRE 用螺絲固定在下方鐵架

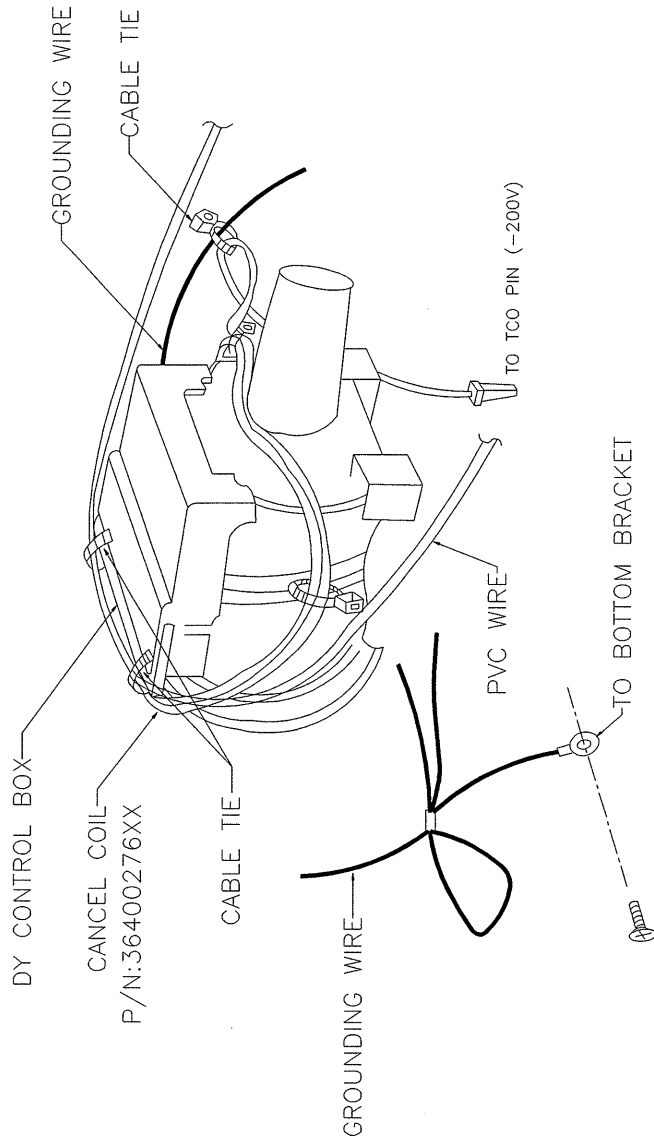

Confidential - Do Not Copy

<p><b>ViewSonic Corporation</b></p> <p>THESE DRAWINGS AND SPECIFICATIONS ARE THE PROPERTY OF DELTA ELECTRONICS, INC. AND SHALL NOT BE REPRODUCED OR USED AS THE BASIS FOR THE MANUFACTURE OR SELL OF APPARATUS OR DEVICES WITHOUT PERMISSION.</p>	<p>DIMENSIONAL TOLERANCES</p> <table border="1"> <tr> <th>SCALE</th> <th>UNIT</th> <th>mm</th> <th>USED ON</th> </tr> <tr> <td>( )</td> <td></td> <td></td> <td>DF-995 SC 01</td> </tr> </table>		SCALE	UNIT	mm	USED ON	( )			DF-995 SC 01	<p>Drawn: 詹敏秀 08/04/00</p> <p>Designed: 李育鑫 08/04/00</p> <p>Checked: 江政道 08/04/00</p> <p>Approved: 王文彬 08/04/00</p>		<p>DESCRIPTION:</p> <p>ENGINEERING NOTICES</p>	
	SCALE	UNIT	mm	USED ON										
	( )			DF-995 SC 01										
	<p>( ) UP-100 : ±0.2</p> <p>( ) UP-150 : ±0.25</p> <p>( ) 100-150 : ±0.25</p> <p>( ) 150-200 : ±0.25</p> <p>( ) 200-250 : ±0.25</p> <p>( ) 250-300 : ±0.4</p> <p>( ) 300-350 : ±0.45</p> <p>( ) 350-400 : ±0.5</p>		<p>THIRD ANGLE PROJECTION</p>		<p>DRAWING NO.: 336M2095</p>									
<p>( ) UP-600 : ±1.5</p> <p>( ) 600-900 : ±2.4</p> <p>( ) 900-OVER : ±3.1</p>		<p>SIZE</p> <p>A4</p>		<p>SHEET</p> <p>18 TO 19</p>										
<p>REVISIONS</p>		<p>REV.</p>		<p>00</p>										

1 2 3 4

FRAME NAME : PR5-6R00.DWG

1 2 3 4

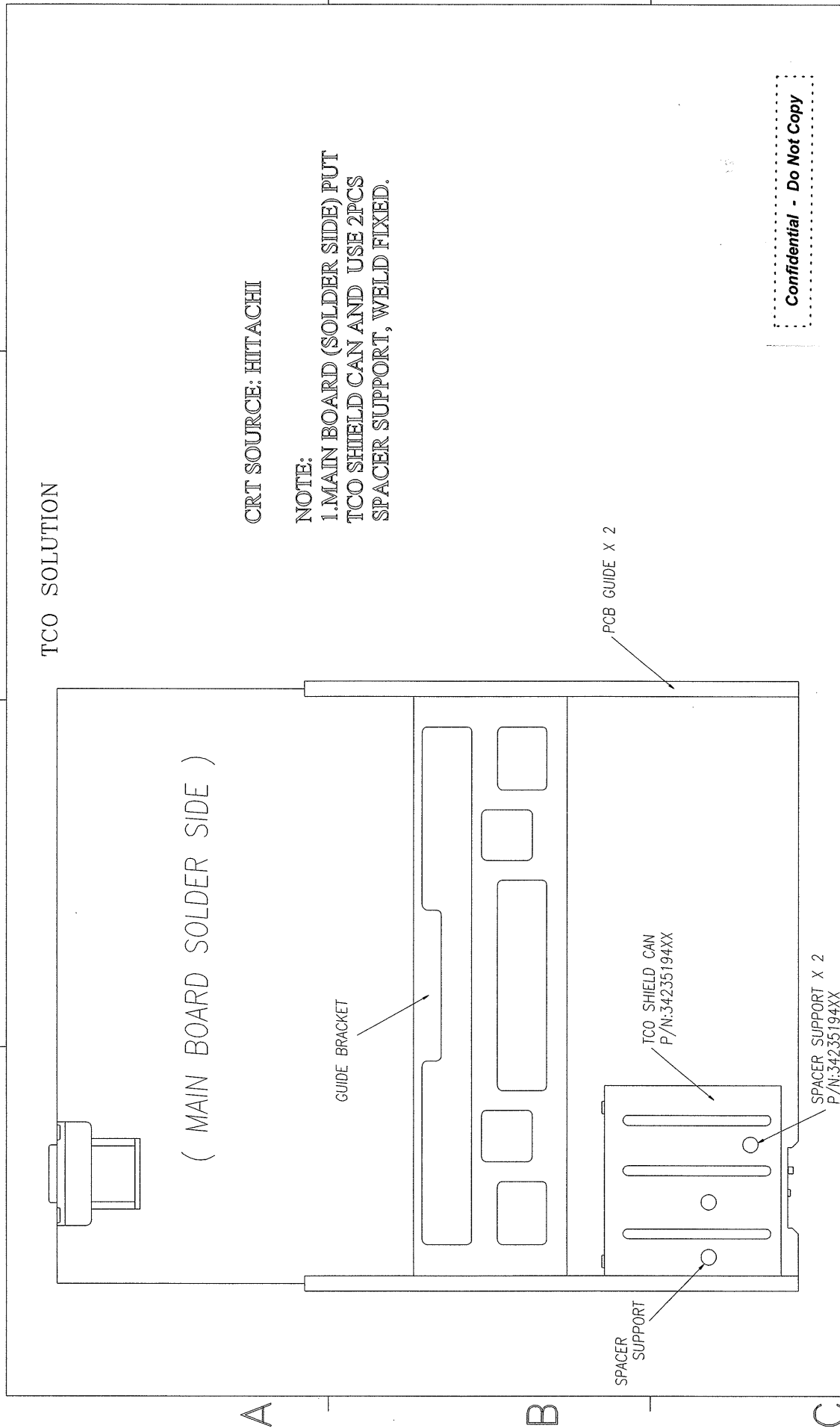

CRT SOURCE: HITACHI  
 NOTE:  
 1.MAIN BOARD (SOLDER SIDE) PUT  
 TCO SHIELD CAN AND USE 2PCS  
 SPACER SUPPORT, WELD FIXED.

Confidential - Do Not Copy

<b>ViewSonic Corporation</b> <small>THESE DRAWINGS AND SPECIFICATIONS ARE THE PROPERTY OF DELTA ELECTRONICS, INC. AND SHALL NOT BE REPRODUCED OR USED AS THE BASIS FOR THE MANUFACTURE OR SELL OF APPARATUS OR DEVICES WITHOUT PERMISSION.</small>		DIMENSIONAL TOLERANCES ( ) ( ) UP-100 : ±0.2 100-250 : ±0.25 200-250 : ±0.35 250-300 : ±0.4 300-350 : ±0.45 350-400 : ±0.5 UP-600 : ±1.5 600-900 : ±2.4 900-OTHER : ±3.1		Drawn: 詹敏秀 05/16/00 Designed: 李育鑫 08/04/00 Checked: 江政道 08/04/00 Approved: 王文彬 05/16/00	DESCRIPTION: ENGINEERING NOTES REV. 00 DRAWING NO.: 336M2095 SHEET 19 TO END
SCALE: 1:1 UNIT: MM USED ON: DE-995 SC 01		THIRD ANGLE PROJECTION A4 SIZE	SHEET 19 TO END		

MPR II solution

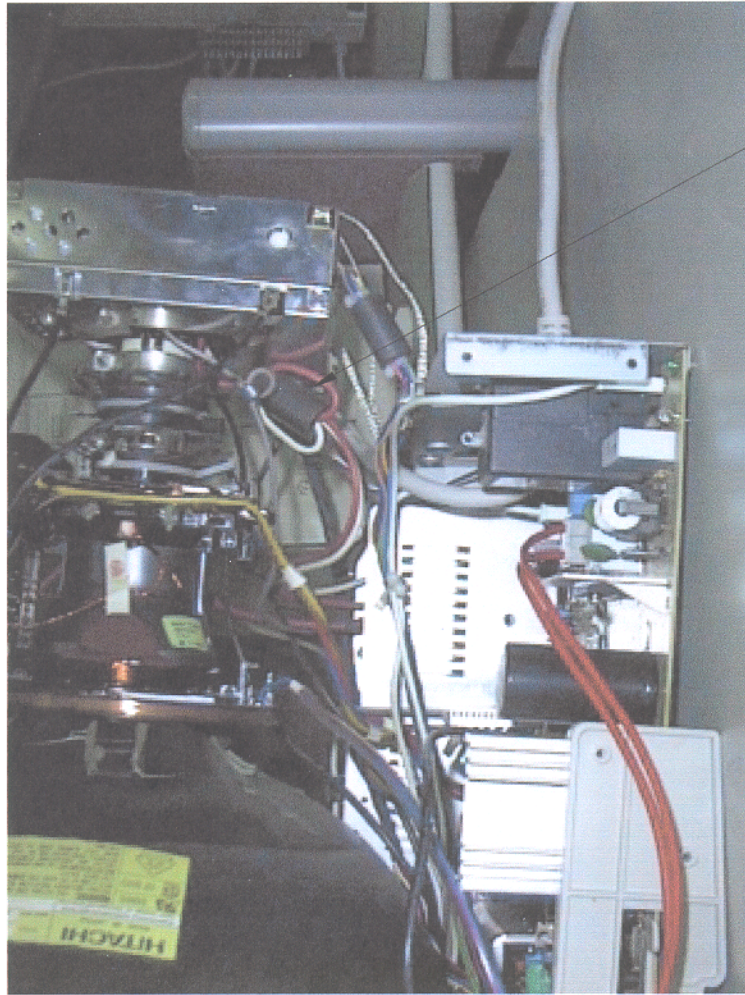

Put the Focus wire under the CRT neck.  
Don't use cable tie.

Confidential - Do Not Copy

ViewSonic Corporation		( ) UP-100 : ±0.2 100-150 : ±0.25 150-200 : ±0.3 200-300 : ±0.4 300-500 : ±0.46 350-400 : ±0.5		( ) UP-800 : ±1.5 800-900 : ±2.4 900-OVER : ±3.1		Drawn: 詹敏秀 05/16/00 Designed: 謝坤儒 05/16/00 Checked: 柯金昆 05/16/00 Approved: 詹明德 05/16/00		DESCRIPTION: ENGINEERING NOTICES	
THESE DRAWINGS AND SPECIFICATIONS ARE THE PROPERTY OF DELTA ELECTRONICS, INC. AND SHALL NOT BE REPRODUCED OR USED AS THE BASIS FOR THE MANUFACTURE OR SELL OF APPARATUS OR DEVICES WITHOUT PERMISSION		DIMENSIONAL TOLERANCES ( ) DECIMALS X : ±0.3 XX : ±0.2 XIX : ±0.1 ANGLES: ±0.5°		( ) UNIT MM USED ON DE-995 SB 01		THIRD ANGLE PROJECTION A4 DRAWING NO.: 336M2068		SHEET 17 TO END REV. 00	
SCALE		H		UNIT		MM		SIZE	



## 8. G90f Mechanical Parts List

		G90f
Item	Part Description	Part No.
1	FRONT BEZEL	3361026300
2	POWER KNOB	3360606900
3	POWER SPRING	3422101700
4	LED LENS	3360502200
5	SCREW LOCKED TAPPING	3109030900
6	PCB GUIDE - R	3360901400
7	PCB GUIDE - L	3360901500
8	CRT GROUNDING WIRE	3640018302
9	DEGAUSSING COIL	2840003007
10	SHIELD CAN (BOTTOM)	3423506800
11	SHIELD CAN (TOP)	3423506901
12	REAR BRACKET	3421266501
13	FUNCTION KEY	3360706600
14	RUBBER PAD	3240920800
15	SPONGE	3240499000
16	REAR COVER	3360211000
17	WASHER	3360091500
18	SWIVEL	3360300700
19	BASE	3360402500
20	BASE COVER	3360201800
21	GUIDE BRACKET ASS'Y	3790170000
		3421295400
		3230025000
22	SCREW	3109022200
		3109021001
		3100301000

Confidential - Do Not Copy

4

3

2

1

A

B

C

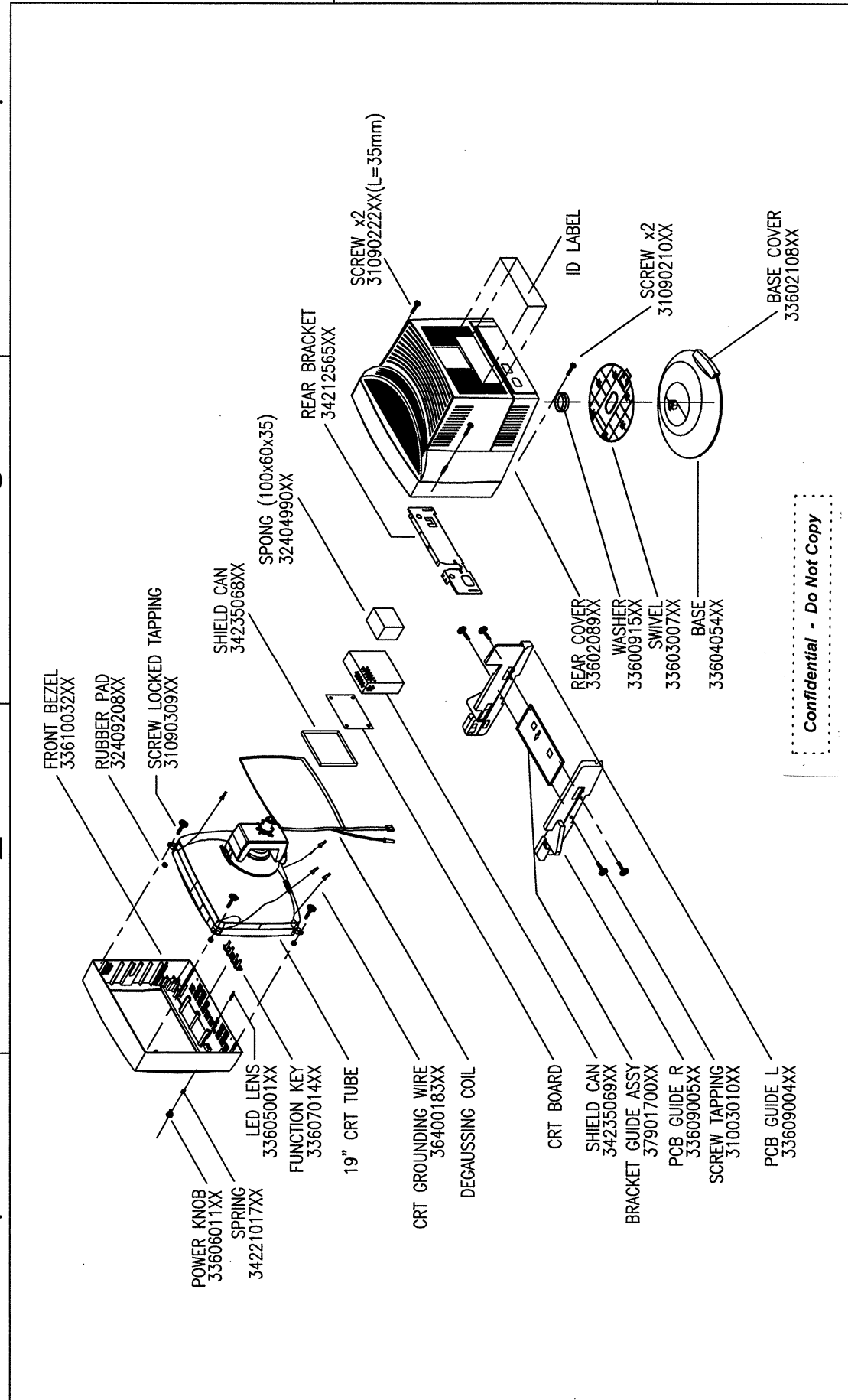

ViewSonic Corporation		Drawn: 詹敏秀 05/16/00		DESCRIPTION: ENGINEERING NOTICES	
THESE DRAWINGS AND SPECIFICATIONS ARE THE PROPERTY OF DELTA ELECTRONICS, INC. AND SHALL NOT BE REPRODUCED OR USED AS THE BASIS FOR THE MANUFACTURE OR SELL OF APPARATUS OR DEVICES WITHOUT PERMISSION.		Designed: 謝坤儒 05/16/00		THIRD ANGLE PROJECTION	
		Checked: 江政道 05/16/00		DRAWING NO.: 336M2095	
		Approved: 詹明禮 05/16/00		REV. 00	
		SCALE: 1/1		SIZE: A4	
		UNIT: MM		SHEET: 3 TO 4	
		USED ON: DE-995 SC 01			
DIMENSIONAL TOLERANCES		UP-100 : ±0.2		UP-500 : ±1.5	
(<30 : ±0.25		100-100 : ±0.25		600-900 : ±2.4	
30-100 : ±0.35		100-200 : ±0.3		900-999 : ±3.1	
>100-300 : ±0.5		200-300 : ±0.36			
300-500 : ±0.6		500-850 : ±0.45			
500-900 : ±0.6		900-1000 : ±0.6			
HOLES: ±0.05		ANGLES: ±0.5°			

4

3

2

1

1 2 3 4

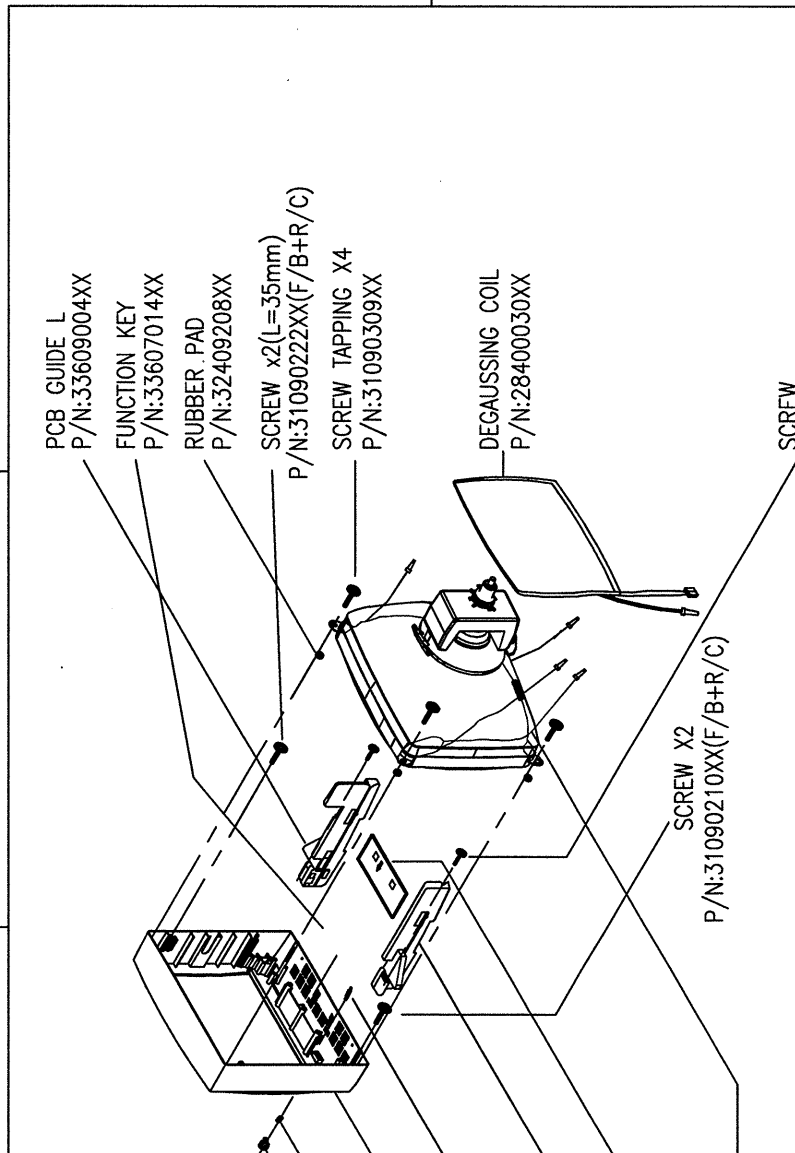

- POWER KNOB  
P/N:33606011XX
- SPRING  
P/N:34221017XX
- FRONT BEZEL  
P/N:33610032XX
- LED LENS  
P/N:33605001XX
- PCB GUIDE-R  
P/N:33609005XX
- BRACKET GUIDE ASSY  
P/N:37901700XX
- CRT Grounding Wire  
P/N:36400183XX
- PCB GUIDE L  
P/N:33609004XX
- FUNCTION KEY  
P/N:33607014XX
- RUBBER PAD  
P/N:32409208XX
- SCREW x2(L=35mm)  
P/N:31090222XX(F/B+R/C)
- SCREW TAPPING X4  
P/N:31090309XX
- DEGAUSSING COIL  
P/N:28400030XX
- SCREW  
P/N:31090210XX

NOTE: UNLESS OTHERWISE SPECIFIED - 組裝

- A. FRONT BEZEL + (POWER KNOB + SPRING) + FUNCTION KEY + LED LENS = FRONT BEZEL ASSY
- 1. POWER KNOB 先放入彈簧再裝入 FRONT BEZEL 時, 注意其方向不可裝反
- 2. FUNCTION KEY 卡入前框後, 並點膠固定之
- 3. LED LENS 裝入前框 BOSS 定位後, 需用烙鐵熱壓緊予以固定
- 4. USE 2 PCS BUMBER FOOT TO FIX FRONT BEZEL BOTTOM, AND PRESS ON WITH BUMBER FOOT.

B. FRONT BEZEL ASSY + CRT ASSY 之組裝

- 1. CRT 放置 F/B 前需先墊 4PCS RUBBER PADS (P/N:32409267XX)
- 2. DEGAUSSING COIL CABLE TIE 固定 CRT 4PCS 角螺帽不拉緊, 等 CRT 與 FRONT BEZEL 鎖上後再拉緊
- 3. 使用 4PCS SCREW WITH LOCK WASHER 先放入 CRT 對準 CRT MOUNTING PURSE LOCK BOSS 孔徑鎖緊, 鎖時注意電動起子扭力設定值 (20~25), 上鎖時依鎖角順序作業原則

ViewSonic Corporation	DIMENSIONAL TOLERANCES		Drawn: 唐敏秀 05/16/00		DESCRIPTION: ENGINEERING NOTICES	
	( )	( )	( )	THIRD ANGLE PROJECTION	DRAWING NO.: 336M2095	REV. 00
THESE DRAWINGS AND SPECIFICATIONS ARE THE PROPERTY OF DELTA ELECTRONICS, INC. AND SHALL NOT BE REPRODUCED OR USED AS THE BASIS FOR THE MANUFACTURE OR SELL OF APPLIANCES OR DEVICES WITHOUT PERMISSION.	<30	+0.25	UP-100 : ±0.2	A4	SIZE	SHEET 4 TO 5
	>30-100	+0.35	100-150 : ±0.25	600-900 : ±2.4		
	>100-300	+0.5	150-200 : ±0.3	900-9758 : ±3.1		
	>300-500	+0.8	200-300 : ±0.35			
	>500	+1.0	300-350 : ±0.45			
	HOLES: ±0.05		350-400 : ±0.5			
SCALE: 1/1	UNIT: MM	USED ON: DE-995 SC 01				

FRAME NAME : FR5-5R00.DWG 1 2 3 4

## 9. PCB layout diagram

1. Mother board

2. Video board

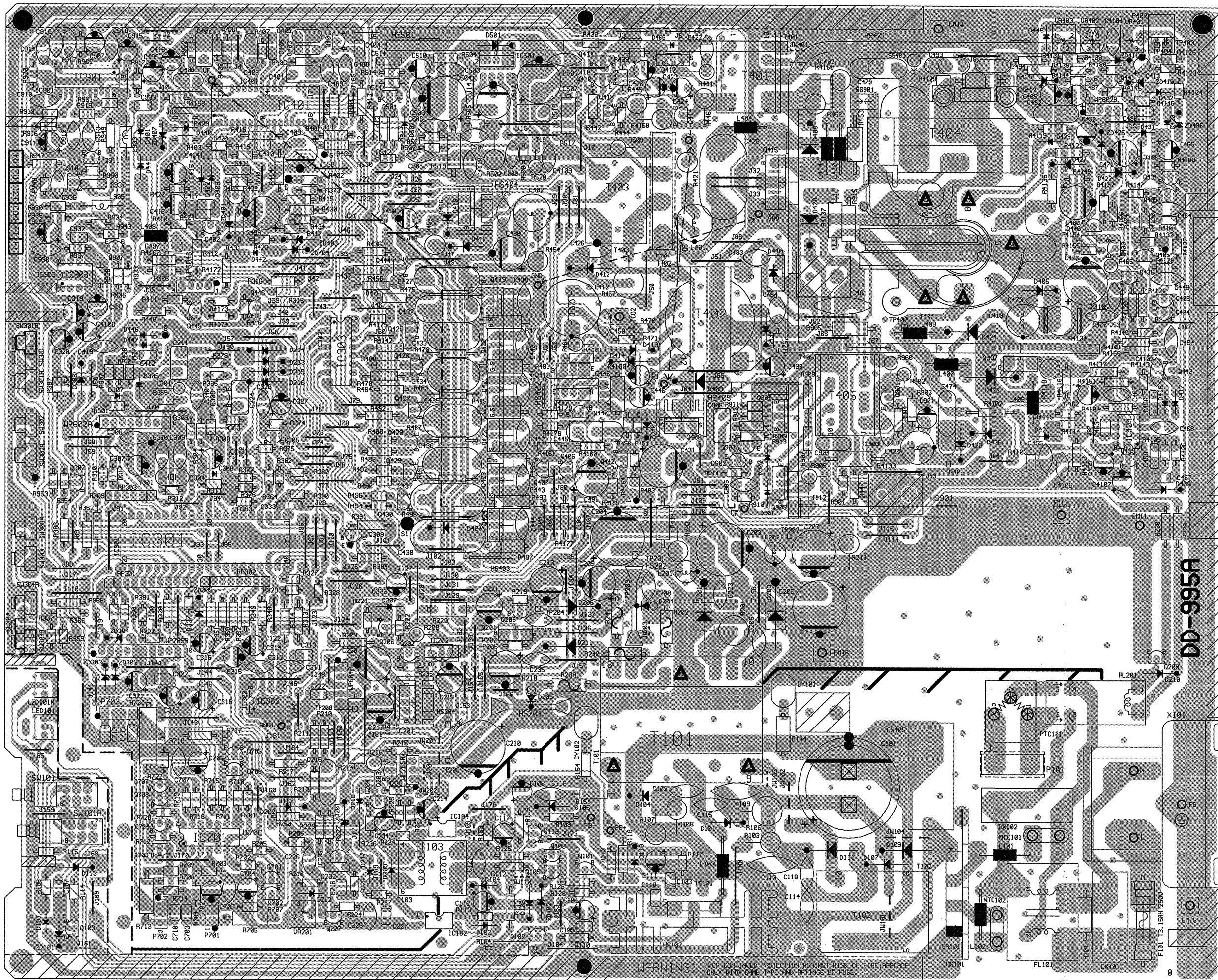

DRAWING NO.: DD-995A REV: 1.00  
 USED ON: DD-995A10 REV: 1.00  
 MADE BY: S.A. CHEUNG DATE: 02-21-2000

COMPONENT SIDE UNIT: MCM2

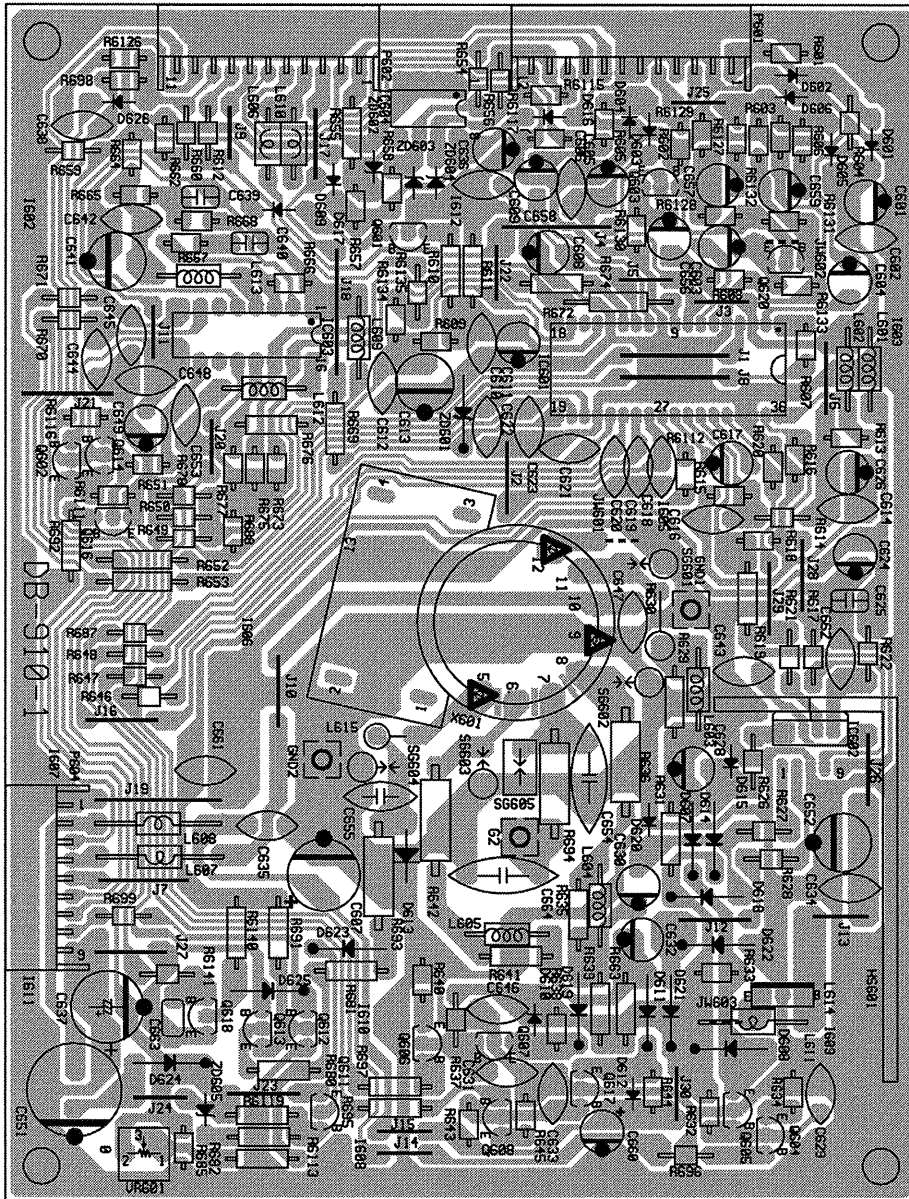

DRAWING NO.: 01PM-1-9101 REV: 1A  
 USED: ON: DB-910-1 REV: 03U  
 MADE BY: PRETTY.GAN DATE: 05/24/2000

COMPONENT SIDE UNIFORM

## 10. G90f RECOMMENDED SPARE PARTS LIST

Location	Part No.	Description	Q'ty (pcs)
* IC101	2510167036	KA2S1265	100
* IC102, IC104	2310040008	TLP721F(D4-GR)	100
* IC203	2500004001	TL431CLP-RA	100
* IC201	2500007001	MC7812CT	100
* IC202	2500064036	XC62AP5002LH	100
* IC301	2610343888	IC 8BIT MASK MICRO	100
* IC302	2610188242	M24C16-BN6	100
* IC303	2610220011	MC14094BCP	100
* IC401	2530092016	TDA4856	100
* IC501	2530010006	TDA8172	100
* IC404	2510005002	UC3843AN	100
IC901	2530054107	M52723ASP	
IC601	2530063207	M52743BSP	
IC602	2500113111	LM2435	
IC603	2530115134	MTV021N-25	
* IC604	2610099042	ST24LC21BB6	100
* R102	0190300403	RES FUSING MF 1W .22 J	100
* R241	0190200403	RES FUSING MF 1/2W .22 J	100
* R4122, R4136, R4137	0190201100	RES FUSING MF 1/2W 2.2 J	100
* R4133	0190300900	RES FUSING MF 1W .33 J	100
* R4141	0190300500	RES FUSING MF 1W 1 J	100
* Q102, Q901	2100072007	MPSA44M	100
* Q205	2100024001	2SC2655Y TEP2	100
* Q201	2130007001	2SB857C	100
* Q408	2420021314	2SJ449	100
Q412, Q420, Q421, Q422, Q423, Q424	2430044215	IRFS630A	
* Q416, Q417, Q905	2120137009	2SD669AWC	100
* Q418, Q904	2130022009	2SB649AC	100
* Q415	2120150006	2SC5411(HFE)	100
Q437	2430078115	SSS10N60A	
* Q604, Q606, Q608, Q611, Q903	2100067006	BF422 (TE2.T)	100
* Q440, Q605, Q607, Q613, Q617, Q902	2110037006	BF423 (TE2.T)	100
* D201, D203	2050252044	RG4C LFL1	100
* D204, D423	2050361644	RG4A-LFJ6	100
* D409	2010901414	RG2	100
D410	2011502109	BY459X-1500	
D424	2010391601	BYM26C	
* D427	2010271801	UF4006	100
* R4135, R4169	2010271401	UF4004	100
* D413, D414, D422	2010271201	UF4003 TAPING	100
T101	2800111100	SMT-42V-866A	

**G90f/A90-2 RECOMMENDED SPARE PARTS LIST**

Location	Part No.	Description	Q'ty (pcs)
T403	2817602248	LINEAR COIL 4.9uH K 4P	
* T401	2802400400	DT-E22-02	100
* T402	2806531200	19A-9007 REV.A	100
* T404	2850005809	FBT 19" 31KHz ~ 106KHz	10
* T405	2806700200	CE-22V-02	100
* Y301	0730240212	CRYSTAL 8MHz 30PPM 30PF	100
* F101	0805340601	FUSE TSC 3.15A UL SEM PIG	100
LED	2300062306	YEL/GRN 5mm 3 PIN	
T102 (For PFC)	2817319880	19A-0012B	
* X601	3020007200	CRT SOCKET	100
	3080300200	SIGNAL CABLE L=1800 BLACK	
* G90f	3500200400	END BLOCK - TOP	30
* G90f	3500200500	END BLOCK - BOTTOM	30
* G90f	TBD	USER MANUAL - 1M	100
* G90f	TBD	USER MANUAL - 1P	100
* G90f	TBD	USER MANUAL - 1E	100
* G90f	TBD	USER MANUAL - 1A	100
* G90f	TBD	USER MANUAL - 1J	100
* G90f	3520093001	PE BAG	100
* G90f	5600010064	MAIN BOARD ASS'Y	10
* G90f	5600010063	VIDEO BOARD ASS'Y	10
G90f	3361026300	FRONT BEZEL PC+ABS	
G90f	3360211000	REAR COVER PC+ABS	
G90f	3368090400	SWIVEL BASE ASS'Y ABS 94HB	
G90f	0741901601	HITACHI CRT 0.25mm 95KHz M46LSQ183X01(W)	
	0741901610	SAMSUNG CRT 0.25mm 95KHz M46QCK761X123(optional)	
* A90-2	3368023500	FRONT BEZEL ABS 94-5V #Y0-487 V	10
* A90-2	3368075000	REAR COVER ABS 94-5V #Y0-487 V	10
* A90-2	3500200200	END BLOCK - TOP	30
* A90-2	3500200300	END BLOCK - BOTTOM	30
* A90-2	3510317400	CARTON	100
* A90-2	5011055800	USER MANUAL	100
* A90-2	3520093001	PE BAG	100
* A90-2	5600010131	MAIN BOARD ASS'Y	10
* A90-2	5600010066	VIDEO BOARD ASS'Y	10
A90-2	3368090400	SWIVEL BASE ASS'Y ABS 94HB # Y0-	
A90-2	0741901810	SAMSUNG CRT 0.26mm 95KHz M46QCE261X112(A)	

**Remark** : Only items with " \* " will be provided to customer as the F.O.C. recommended spare parts.